



AD-120 Parts Manual

Phase 4

1991 thru 1998

American Dryer Corporation
88 Currant Road
Fall River, MA 02720-4781
Telephone: (508) 678-9000 / Fax: (508) 678-9447
E-mail: techsupport@amdry.com

100191
071597

ADC Part No. 450100

Retain This Manual In A Safe Place For Future Reference

American Dryer Corporation products embody advanced concepts in engineering, design, and safety. If this product is properly maintained, it will provide many years of safe, efficient, and trouble-free operation.

ONLY properly licensed technicians should service this equipment.

OBSERVE ALL SAFETY PRECAUTIONS displayed on the equipment or specified in the installation/operator's manual included with the dryer.

WARNING: UNDER NO CIRCUMSTANCES should the door switch or the heat circuit devices ever be disabled.

WARNING: The dryer *must never* be operated with any of the back guards, outer tops, or service panels removed. PERSONAL INJURY or FIRE COULD RESULT.

We have tried to make this manual as complete as possible and hope you will find it useful. ADC reserves the right to make changes from time to time, without notice or obligation, in prices, specifications, colors, and material, and to change or discontinue models.

Important

For your convenience, log the following information:

DATE OF PURCHASE _____ MODEL NO. **AD-120**
DISTRIBUTORS NAME _____
Serial Number(s) _____

Replacement parts can be obtained from your distributor or the ADC factory. When ordering replacement parts from the factory, you can FAX your order to ADC at (508) 678-9447 or telephone your orders directly to the ADC Parts Department at (508) 678-9000. Please specify the dryer **model number** and **serial number** in addition to the **description** and **part number**, so that your order is processed accurately and promptly.

The illustrations on the following pages may not depict your particular dryer exactly. The illustrations are a composite of the various dryer models. Be sure to check the descriptions of the parts thoroughly before ordering.

“IMPORTANT NOTE TO PURCHASER”

Information must be obtained from your local gas supplier on the instructions to be followed if the user smells gas. These instructions must be posted in a prominent location near the dryer.

Table of Contents

Control Door Assembly	2
Microprocessor Control Panel Assembly	3
Control Box Assembly For models mfd. prior to February 4, 1991	4, 5
Control Box Assembly For models mfd. as of February 4, 1991	6, 7
Front Panel / Main Door Assemblies	8, 9
Main Door Switch Assembly	10
Drop Lint Door Assembly	11
Lint Drawer / Lint Drawer Switch Box Assemblies	12
Temperature Sensor Bracket Assembly	13
Basket (Tumbler) / Support Assemblies	14
Tumbler Bearing Mount Assembly	15
Idler Bearing Mount Assembly	16, 17
Totally Enclosed, Fan-Cooled Basket (Tumbler) Motor Mount Assembly	18, 19
Blower Motor Mount Assembly	20, 21
Direct Spark Ignition (DSI) Burner Assembly	22, 23
Direct Spark Ignition (DSI) Module Mount Assembly	24
Sail Switch Assembly	25
Steam Damper Assembly	26, 27
Microprocessor Reversing Control Box Assembly For models mfd. prior to June 21, 1991	28
Microprocessor Reversing Control Box Assembly For models mfd. as of June 21, 1991	29
Back Guard Assembly / Stepdown Transformer	30
Additional Parts Available	31

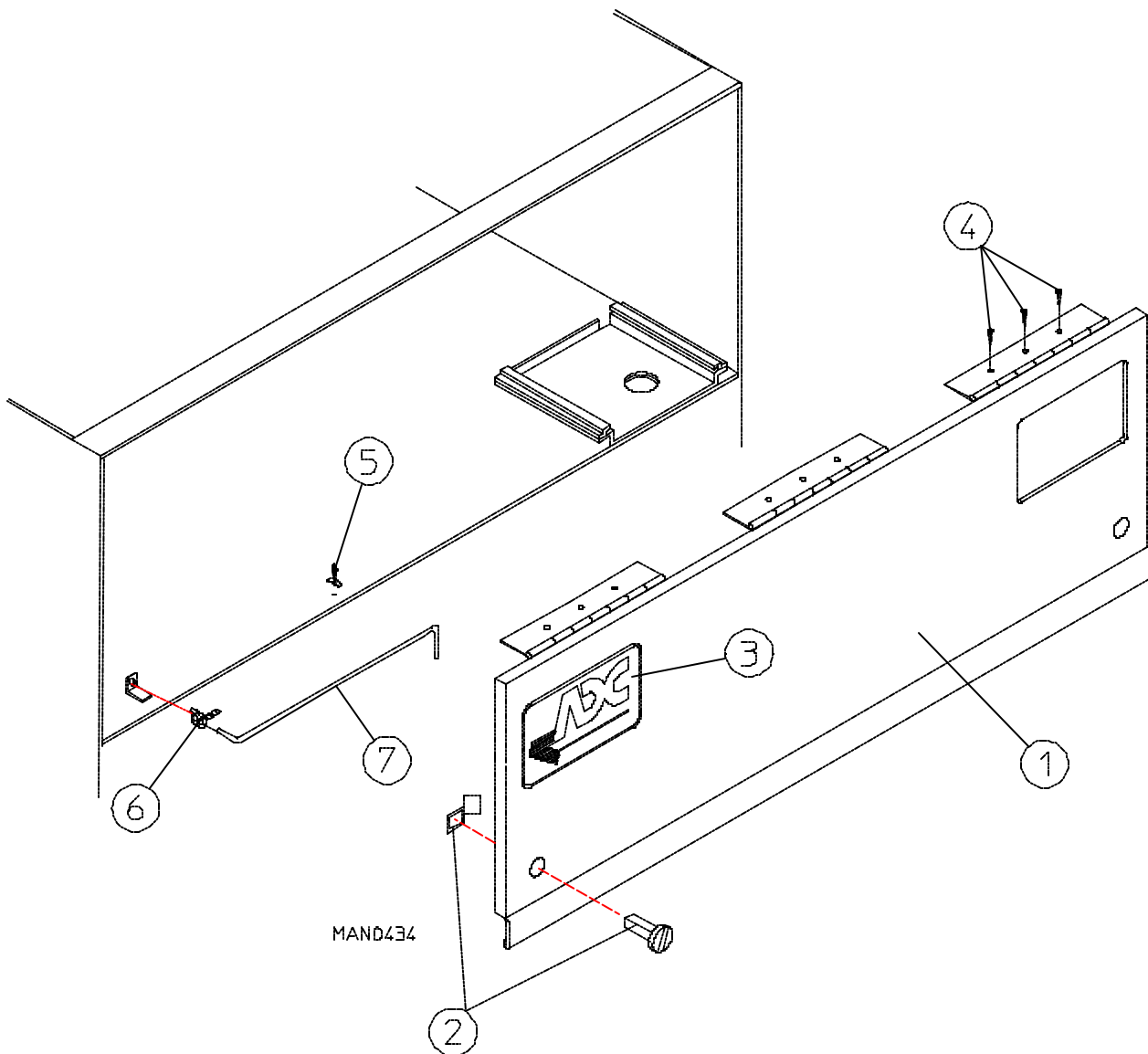

<u>Illus. No.</u>	<u>Part No.</u>	<u>Qty.</u>	<u>Description</u>
1	820010*	1	ADG-120 Control Door Assembly ONLY (for gas models Only)
	820011	1	ADG-120 Stainless Steel Control Door Assembly ONLY (for gas models Only)
	820007*	1	ADS-120 Short Control Door ONLY (for steam models Only)
	820008	1	ADS-120 Stainless Steel Short Control Door ONLY (for steam models Only)
2	160005	2	Spring Turn Latch (2-piece)
3	112360	1	ADC Logo ONLY
	870011	1	Logo Double Tape Kit
4	150415	9	#10-16 x 1/2" Phillips Right-Hand Crimptite Screw
5	102600	1	Control Door Support Rod Catch
6	102601	1	Control Door Rod Retainer Clip
7	102505	1	AD-120 Control Door Support Rod

* Specify color when ordering.

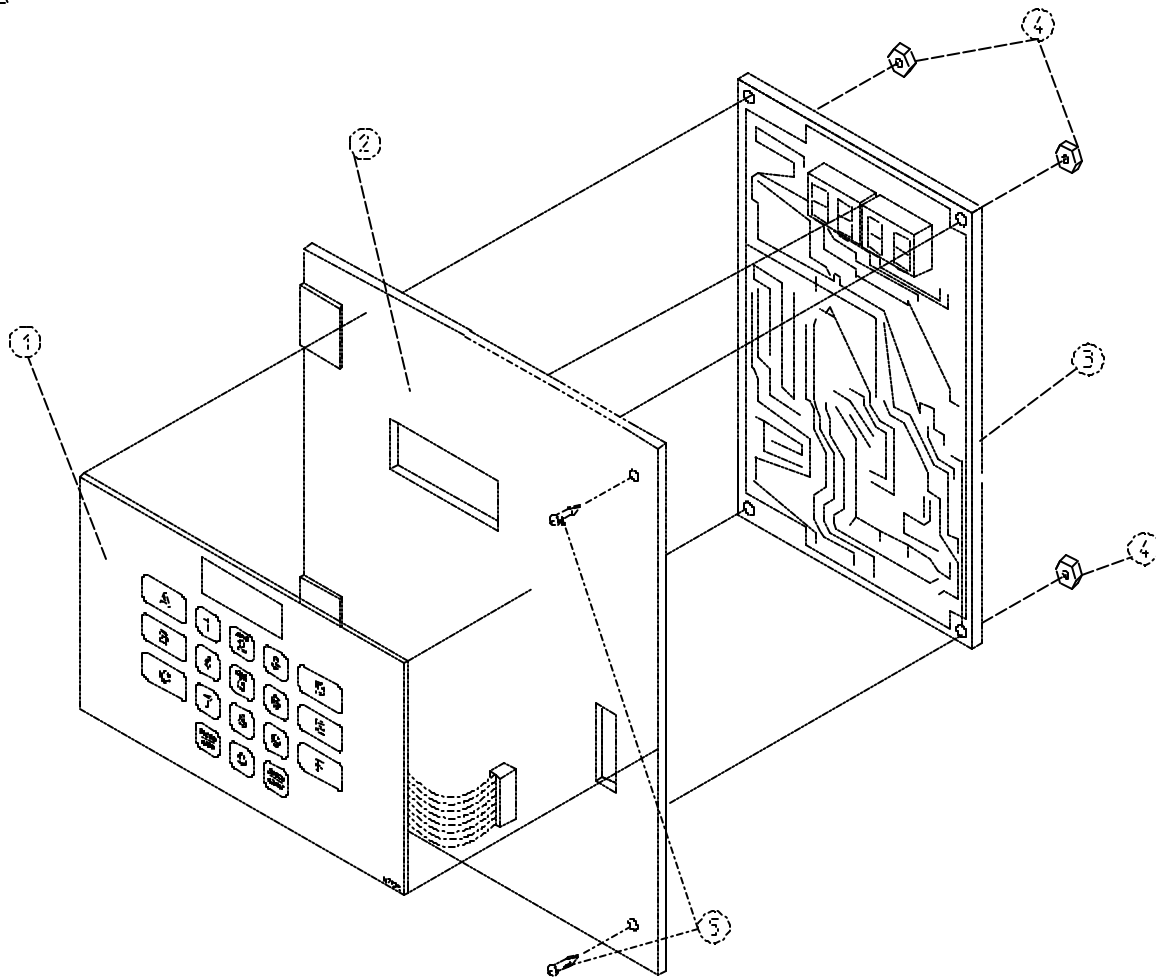

MANG437

Illus. No.	Part No.	Qty.	Description
1	112535	1	OPL English Keyboard Label Assembly
	112276	1	OPL Stick-on Labels (English Only) ... Not Illustrated
	112275	1	OPL Stick-on Labels (Spanish, Italian, and Hebrew) ... Not Illustrated
	112277	1	3-Language OPL Stick-on Labels (English, Spanish, and Hebrew) ... Not Illustrated
	112278	1	5-Language OPL Stick-on Labels (Italian, Dutch, French, German, and Chinese) ... Not Illustrated
2	820105	1	AD-120 Microprocessor Control Panel ONLY
	820013	1	AD-120 Microprocessor Control Panel ONLY with Battery Bracket
	820019	1	AD-120 Microprocessor Control Panel Assembly Complete (includes illus. nos. 1 through 4)
	820018	1	AD-120 Microprocessor Control Panel Assembly Complete with Battery Option (includes illus. nos. 1 through 4)
3	137127	1	Phase 4 OPL Reversing Controller ONLY
	137128	1	Phase 4 OPL Reversing Controller ONLY with Battery Clip
4	152001	4	#8-32 Hex Nut
5	150301	2	#8-18 x 7/16" Phillips Pan Head TEK Screw

IMPORTANT: Check label on computer chip to verify correct part number.

For models mfd. prior to February 4, 1991

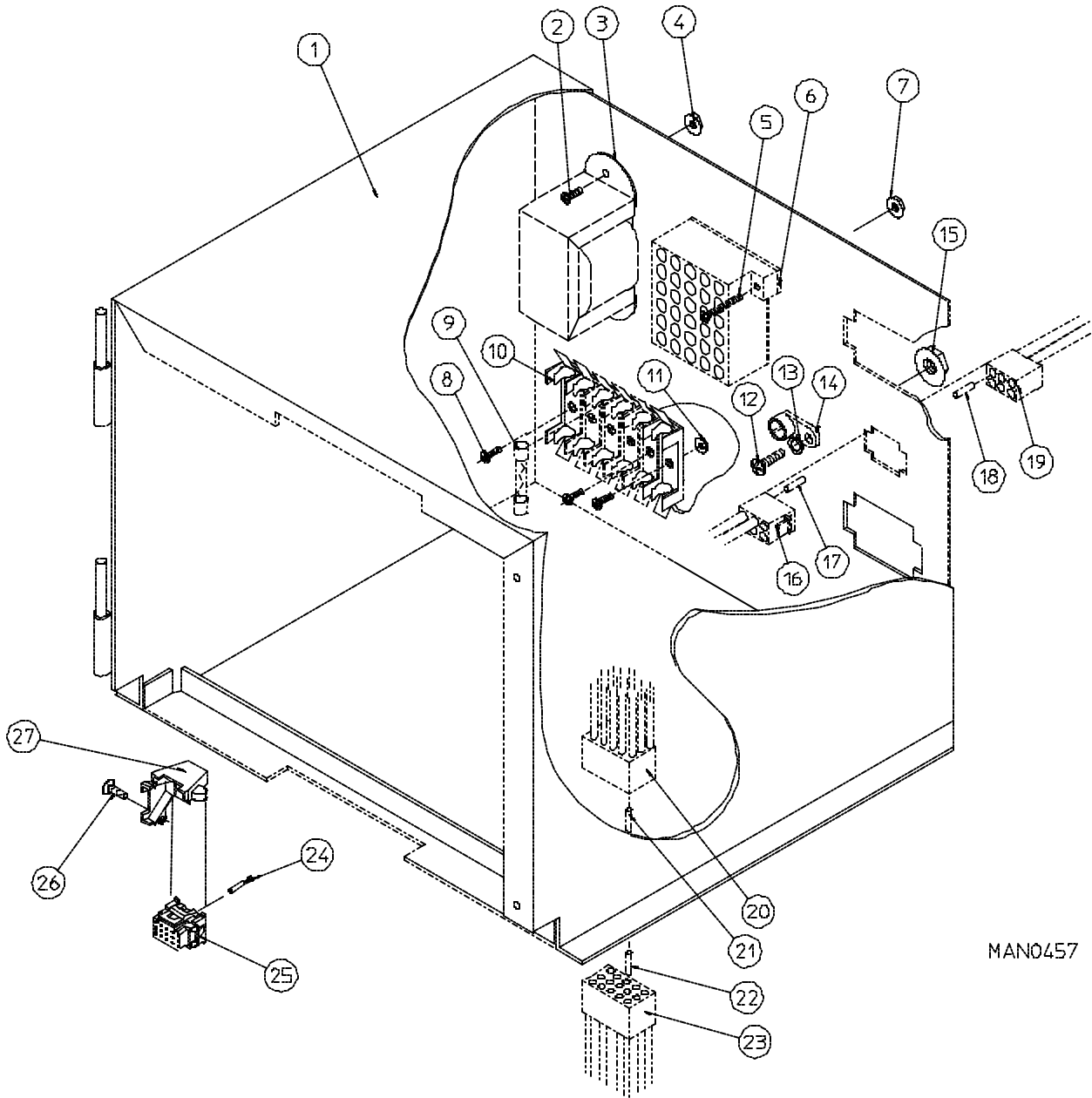

MAN0457

For models mfd. prior to February 4, 1991

<u>Illus. No.</u>	<u>Part No.</u>	<u>Qty.</u>	<u>Description</u>
1	820016	1	AD-120 Control Box Assembly Complete (includes illus. nos. 1 through 17, 20, and 21)
2	150100	2	#8-32 x 1/2" Right-Hand Machine Screw
3	141403	1	DSI 24VAC Transformer
4	151001	2	#8-32 Pal Nut
5	150002	2	#6-32 x 1" Right-Hand Machine Screw
6	120715	1	30-Position Terminal Block
7	151000	2	#6-32 Pal Nut
8	150102	3	#8 x 3/8" Phillips Pan Head TEK Screw
9	136057	6	1/2-Amp (Slo Blo) Fuse ONLY
10	136009	1	5-Position Fuse Block ONLY
	136008	1	Fuse Block / Strip ONLY
11	151001	3	#8-32 Pal Nut
12	150111	1	1/4-20 x 1/2" Right-Hand Machine Screw
13	153021	1	1/4" Shakeproof Washer
14	121010	1	L-70 Ground Lug
15	152002	1	1/4-20 Hex Nut
16	122631	1	6-Pin Socket Connector ONLY
17	122705	2	Socket Terminal ONLY
18	122704	2	Pin Terminal ONLY
19	122630	1	6-Pin Connector ONLY
	137025	1	6/15 Position Strain Relief ... Not Illustrated
20	122625	1	15-Pin Connector ONLY
21	122704	14	Pin Terminal ONLY
22	122705	14	Socket Terminal ONLY
23	122626	1	15-Pin Socket Connector ONLY
24	137021	14	Microprocessor Socket ONLY
25	137020	1	15-Pin Microprocessor Connector ONLY
26	150315	1	#6 x 3/8" Phillips Pan Head Screw
27	137022	1	15-Pin Strain Relief ONLY
--	122800	1	Microprocessor (female) Pin Extraction Tool
--	122801	1	Pin/Socket Extraction Tool

For models mfd. as of February 4, 1991

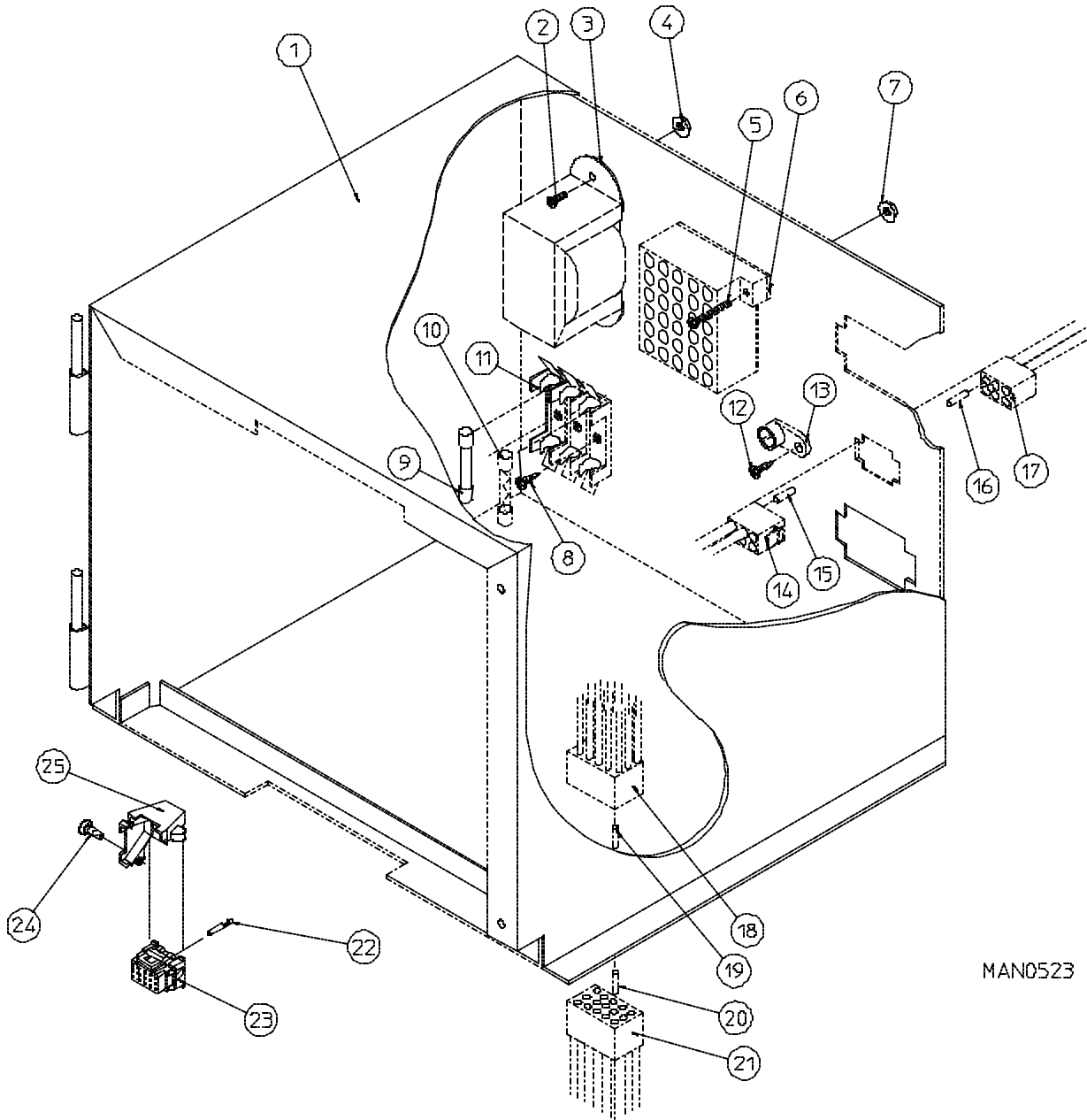

MAN0523

For models mfd. as of February 4, 1991

<u>Illus. No.</u>	<u>Part No.</u>	<u>Qty.</u>	<u>Description</u>
1	820016	1	AD-120 Control Box Assembly Complete (includes illus. nos. 1 through 15, 18, and 19)
2	150100	2	#8-32 x 1/2" Right-Hand Machine Screw
3	141403	1	DSI 24VAC Transformer (for gas models Only)
4	151001	2	#8-32 Pal Nut
5	150002	2	#6-32 x 1" Right-Hand Machine Screw
6	120715	1	30-Position Terminal Block
7	151000	2	#6-32 Pal Nut
8	150102	3	#8 x 3/8" Phillips Pan Head TEK Screw
9*	136014	1	3-Amp (Very Fast Acting) Fuse ONLY
10*	136057	2	1/2-Amp (Slo Blo) Fuse ONLY
11	136008	3	Fuse Block/Strip ONLY
12	150415	1	#10-16 x 1/2" Phillips Right-Hand Crimptite Screw
13	121010	1	L-70 Ground Lug
14	122631	1	6-Pin Connector ONLY
15	122705	**	Socket Terminal ONLY
16	122704	**	Pin Terminal ONLY
17	122630	1	6-Pin Connector ONLY
	137025	1	6/15 Position Strain Relief ... Not Illustrated
18	122625	1	15-Pin Connector ONLY
19	122704	14	Pin Terminal ONLY
20	122705	14	Socket Terminal ONLY
21	122626	1	15-Pin Socket Connector ONLY
22	137021	14	Microprocessor Socket ONLY
23	137020	1	15-Pin Microprocessor Connector ONLY
24	150315	1	#6 x 3/8" Phillips Pan Head Screw
25	137022	1	15-Pin Strain Relief ONLY
--	122800	1	Microprocessor (female) Pin Extraction Tool
--	122801	1	Pin/Socket Extraction Tool

* Check fuse rating for verification.

* As required (either 2 or 3).

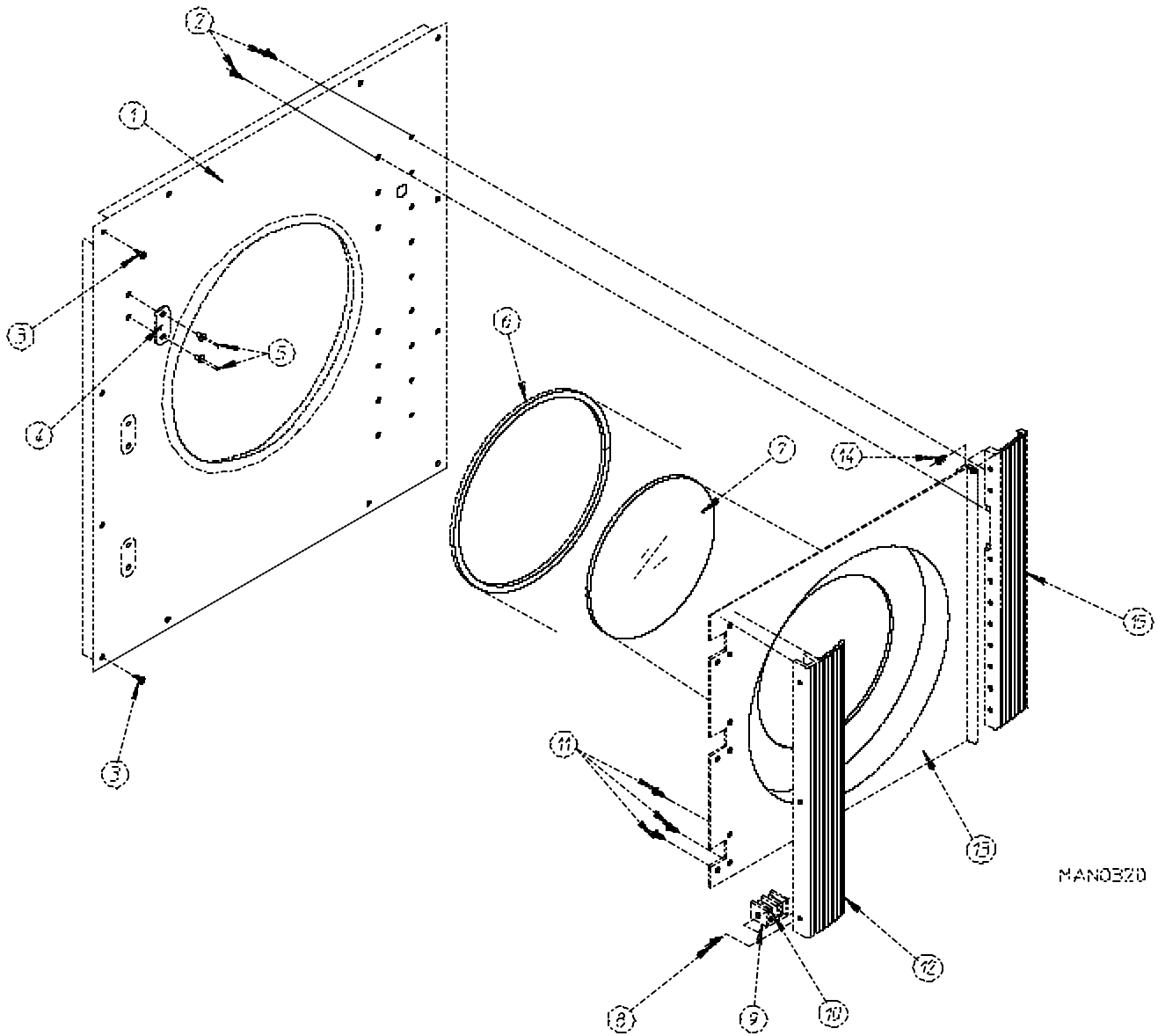

MAN0320

<u>Illus. No.</u>	<u>Part No.</u>	<u>Qty.</u>	<u>Description</u>
1	820012*	1	AD-120 Right Hand Front Panel Assembly (includes illus. nos. 1, 4, and 5)
	820014	1	AD-120 Stainless Steel Right Hand Front Panel Assembly (includes illus. nos. 1, 4, and 5)
2	150402	15	#10-24 x 5/8" Special Head Machine Screw
3	150415	12	#10-16 x 1/2" Phillips Right-Hand Crimptite Screw
4	170340	3	3-1/2" Stainless Steel Striker Pad
5	154200	6	5/32" Pop Rivet
6	102308	1	AD-120 Door Gasket ONLY (94" length)
7	102210	1	20-7/16" Door Glass ONLY
	170725	1	Glass and Gasket Adhesive
8	150401	3	#10-24 x 1-1/4" Phillips Taptite Screw
9	306801	6	Magnet Keeper ONLY
10	102100	6	1" x 1" x 1/4" Main Door Magnet ONLY
11	150415	9	#10-16 x 1/2" Phillips Right-Hand Crimptite Screw
12	170201	1	35" Main Door Handle ONLY
13	800110*	1	AD-120 Main Door Assembly Complete (includes illus. nos. 6 through 13)
	800111	1	AD-120 Stainless Steel Main Door Assembly Complete (includes illus. nos. 6 through 13)
	800122*	1	AD-120 Main Door Assembly with Glass and Gasket ONLY (includes illus. nos. 6, 7, and 13)
	800123	1	AD-120 Stainless Steel Main Door Assembly with Glass and Gasket ONLY (includes illus. nos. 6, 7, and 13)
14	150430	10	#10 x 1/2" Phillips Self Drilling Screw
15	170210	1	35" Main Door Hinge Block ONLY

* Specify color when ordering.

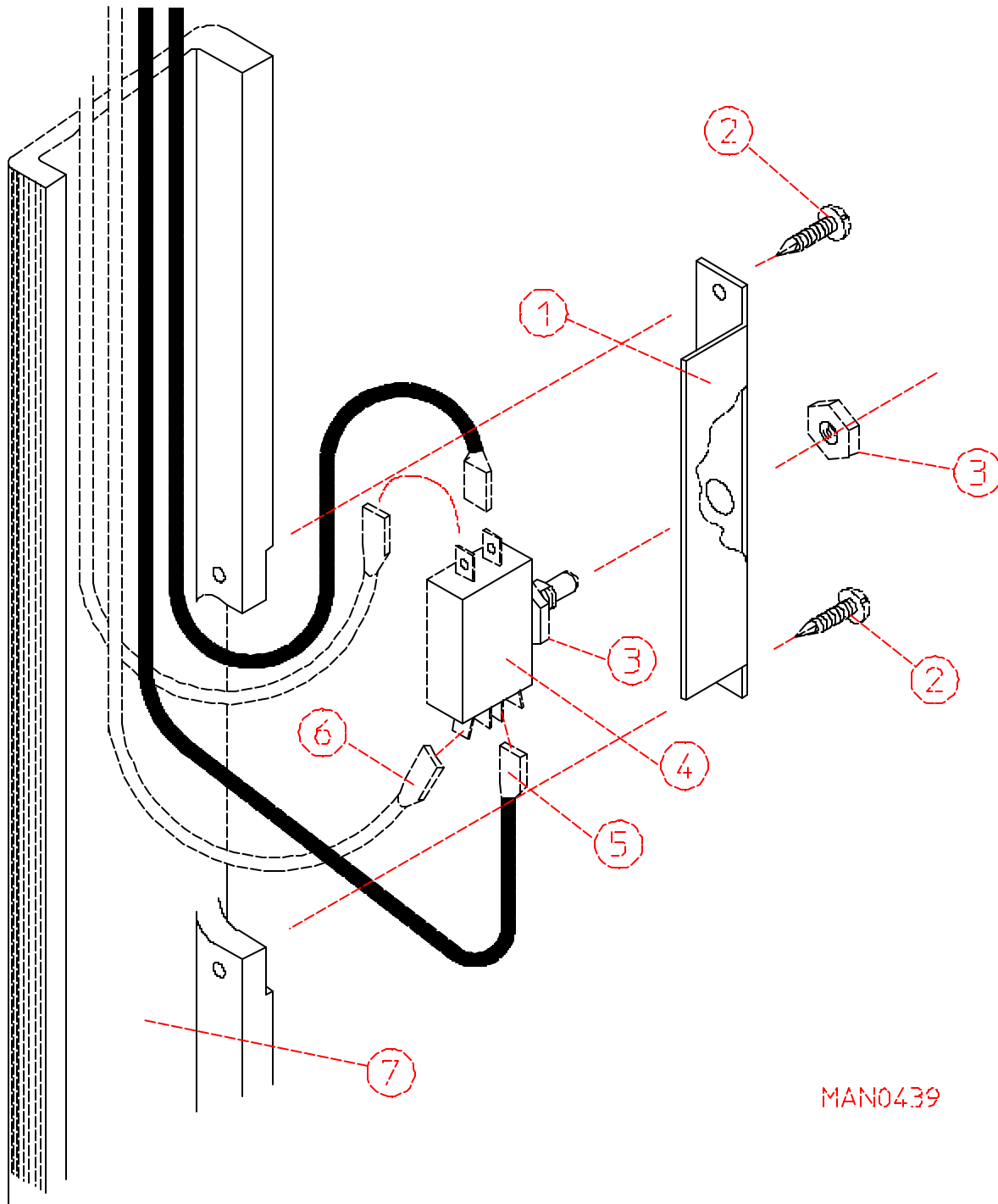

MAN04.39

<u>Illus. No.</u>	<u>Part No.</u>	<u>Qty.</u>	<u>Description</u>
1	313208	1	Door Switch Bracket
2	150415	2	#10-16 x 1/2" Phillips Right-Hand Crimptite Screw
3	152003	2	3/8-32 x 1/2" x 1/16" Door Switch Nut
4	137006	1	Door Switch ONLY
5	121028	2	1/4" x .032 Insulated Terminal ONLY
6	121027	2	3/16" x .032 Insulated Terminal ONLY
7	170210	1	35" Main Door Hinge Block ONLY

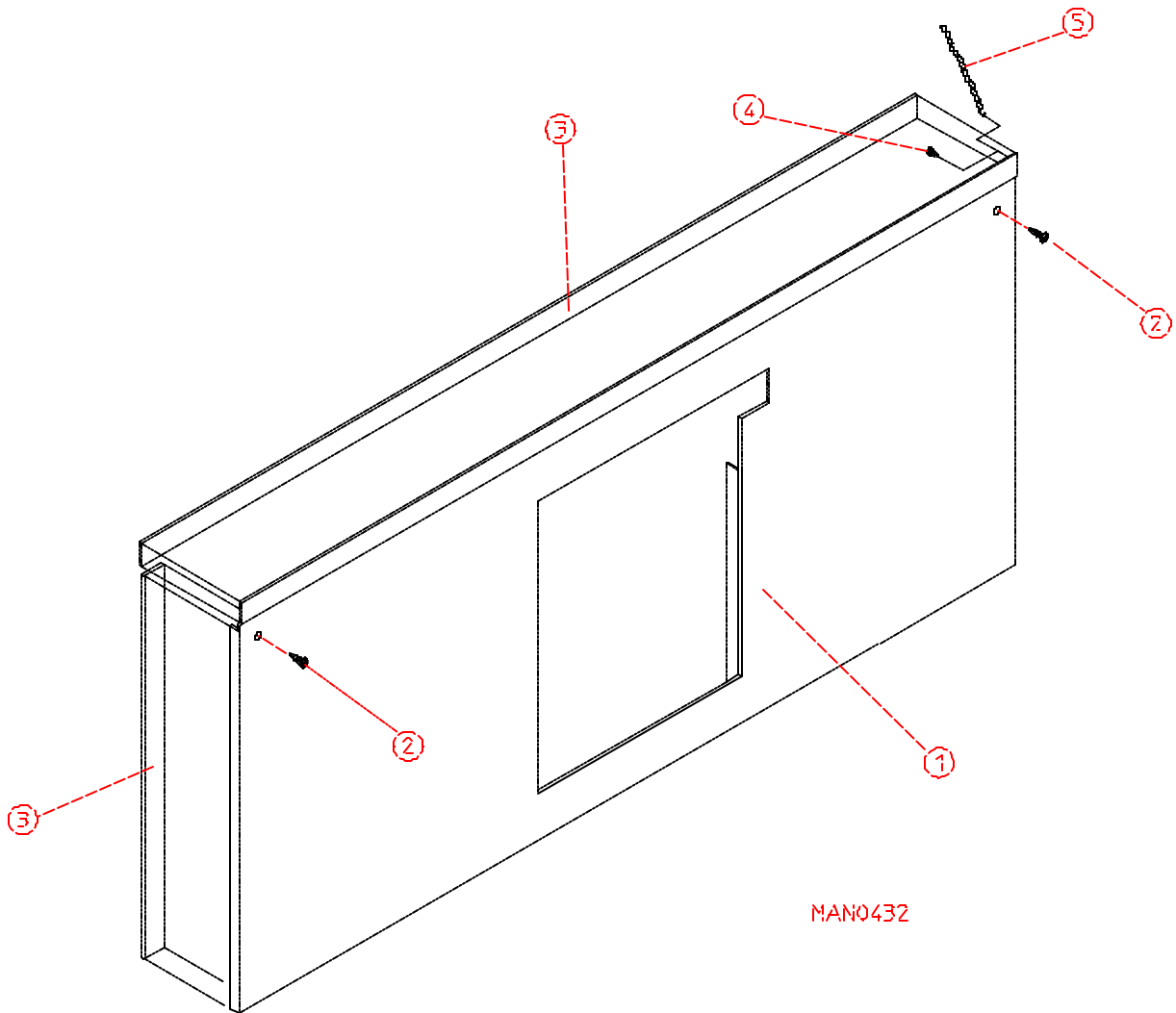

Illus. No.	Part No.	Qty.	Description
1	820015*	1	AD-120 Drop Lint Door Assembly (includes illus. nos. 1 and 3)
	820021	1	AD-120 Stainless Steel Drop Lint Door Assembly (includes illus. nos. 1 and 3)
2	150415	3	#10-16 x 1/2" Phillips Right-Hand Crimptite Screw
3	117604	5	1/8" x 3/8" Neo. Sponge Tape
4	150419	2	#6 x 1/2" Tamperproof TEK Screw
5	108120	1	Chain For Drop Lint Door (10-1/2" length)
--	150418	1	Tamperproof Screw Hand Driver

* Specify color when ordering.

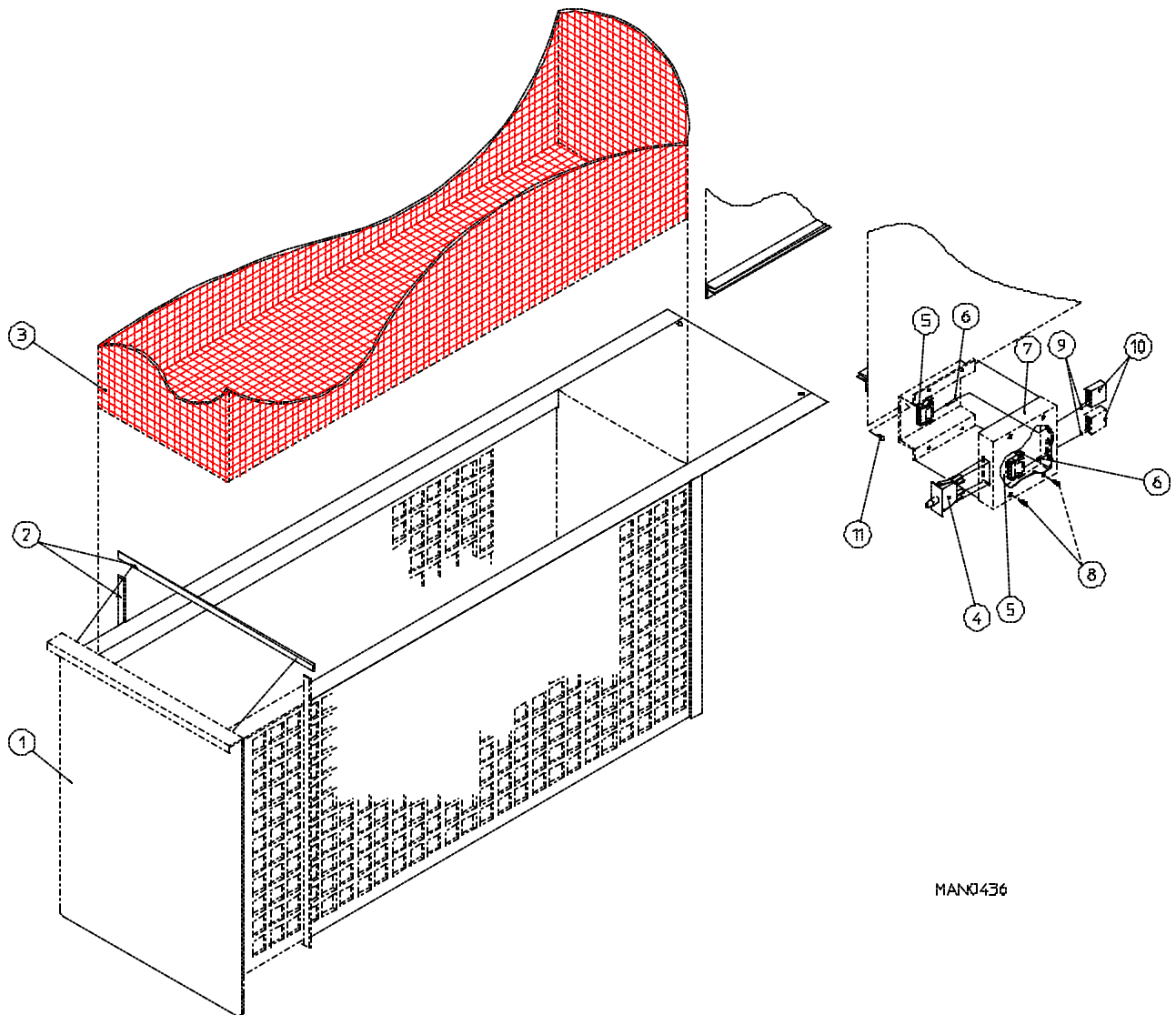

MAN0436

<u>Illus. No.</u>	<u>Part No.</u>	<u>Qty.</u>	<u>Description</u>
1*	820005	1	AD-120 Lint Drawer Assembly Complete (includes illus. nos. 1 and 2)
2	117604	10	1/8" x 3/8" Neo. Sponge Tape
3	820017	1	AD-120 Lint Screen Assembly ONLY
4	122115	1	Lint Drawer Switch ONLY
5	122605	2	4-Pin Socket Connector ONLY
6	122701	8	Socket Terminal ONLY
	122801	1	Pin/Socket Extraction Tool
7	800261	1	Lint Drawer Switch Box Assembly Complete (includes illus. nos. 4 through 7)
	304307	1	Lint Drawer Switch Box ONLY
8	150301	4	#8-18 x 7/16" Phillips Pan Head TEK Screw
9	122700	8	Pin Terminal ONLY
10	122604	2	4-Pin Connector ONLY
11	150301	2	#8-18 x 7/16" Phillips Pan Head TEK Screw

* Specify color when ordering.

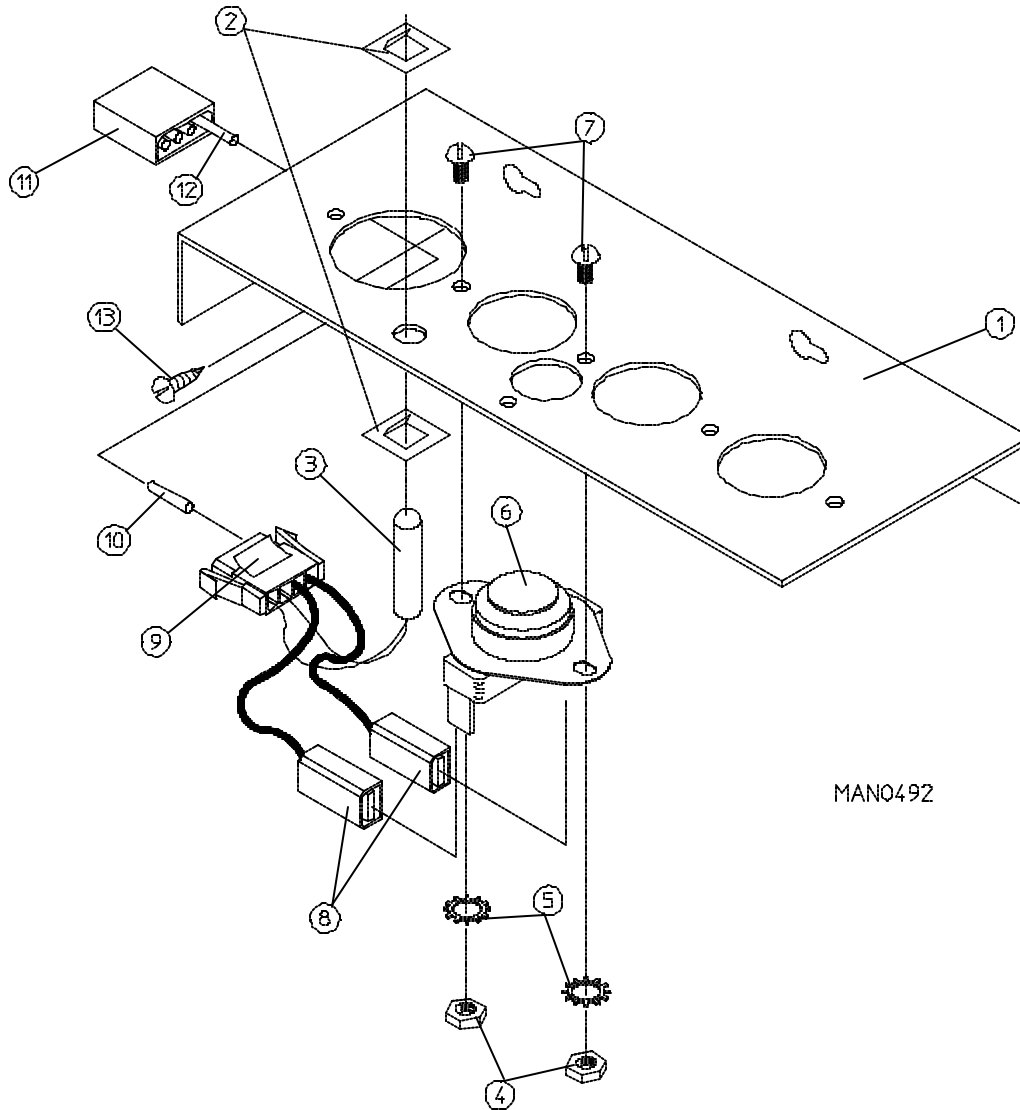

MANQ492

<u>Illus. No.</u>	<u>Part No.</u>	<u>Qty.</u>	<u>Description</u>
1	820022	1	AD-120 Temperature Sensor Bracket Assembly Complete (includes illus. nos. 1 through 10)
	331295	1	AD-120 Temperature Sensor Bracket ONLY
2	154007	2	1/4" Tinnerman Push-On Fastener
3	880251	1	1/4" Temperature Sensor Probe Assembly (includes illus. nos. 2, 3, 8, 9, and 10)
4	152000	2	#6-32 Hex Nut
5	153010	2	#6 Star Washer
6	130103	1	225° Large Automatic Reset Thermostat
7	150000	2	#6-32 x 1/4" Right-Hand Machine Screw
8	121028	2	Insulated Terminal ONLY
9	122605	1	4-Pin Socket Connector ONLY
10	122701	4	Socket Terminal ONLY
11	122604	1	4-Pin Connector ONLY
12	122700	4	Pin Terminal ONLY
	122801	1	Pin/Socket Extraction Tool
13	150301	2	#8-18 x 7/16" Phillips Pan Head TEK Screw

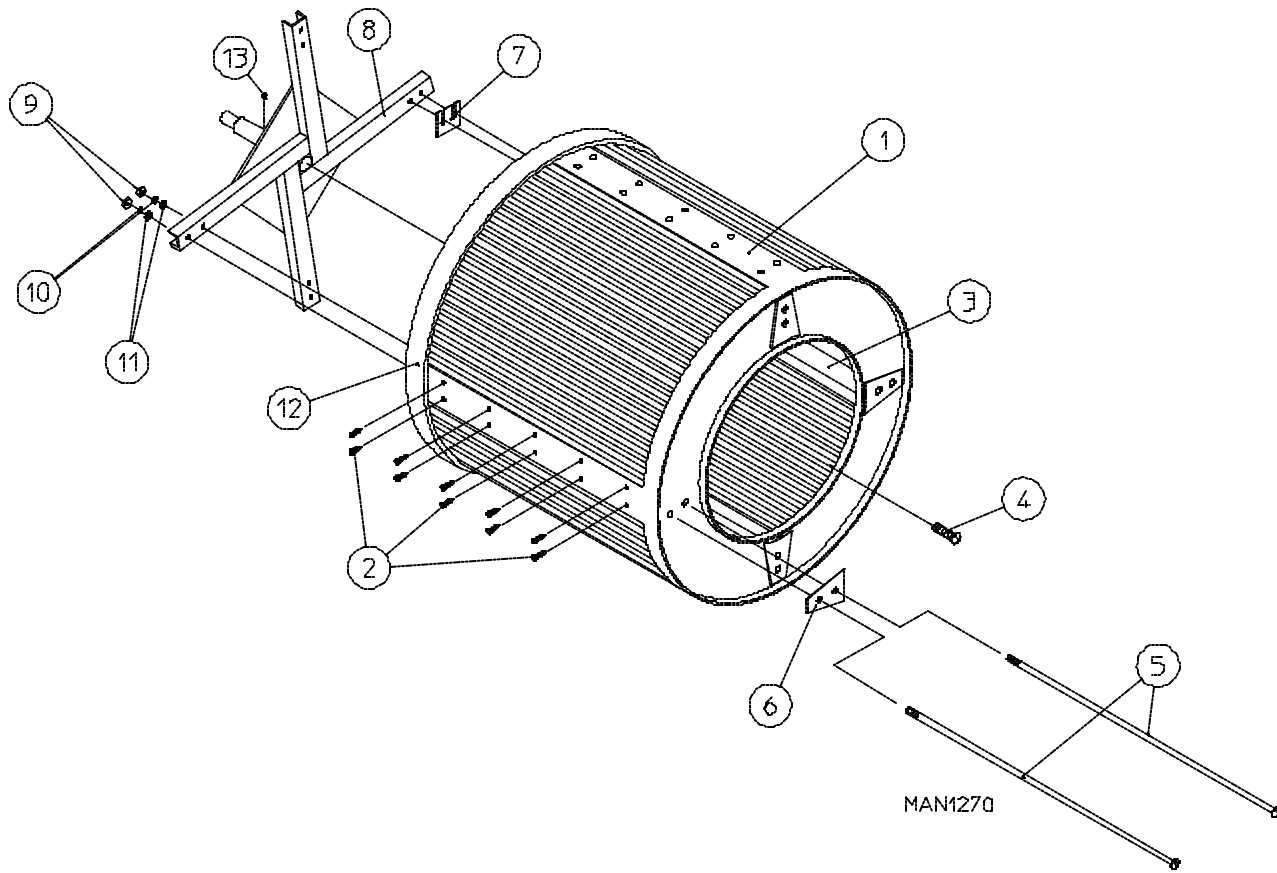

<u>Illus. No.</u>	<u>Part No.</u>	<u>Qty.</u>	<u>Description</u>
1	820110*	1	AD-120 Basket ONLY without Felt Collar
	820111*	1	AD-120 Stainless Steel Basket ONLY without Felt Collar
	820020	1	AD-120 Basket and Support Assembly Complete (includes illus. nos. 1 through 12)
	820030	1	AD-120 Stainless Steel Basket and Support Assembly Complete (includes illus. nos. 1 through 12)
2	150415	40	#10-16 x 1/2" Phillips Right-Hand Crimplite Screw
3	331105	4	AD-120 Basket Rib ONLY
	331106	4	AD-120 Stainless Steel Basket Rib ONLY
4	150500	1	5/16-18 x 3/4" Socket Button Head Screw
5	880967	8	44" Tie Rod Kit
6	301700	4	Basket Reinforcing Plate ONLY
7	301701	**	AD-120 Basket Shim ONLY
8	820115	1	AD-120 Basket Support ONLY
9	153011	8	7/16" Flat Washer
10	153026	8	7/16" Lock Washer
11	152011	8	7/16-14 Hex Nut
12	116006	1	Felt Collar ONLY
13	821002	1	Rotation Sensor Manager Holder Assembly (Option)
---	401010	1	#847 Adhesive for Felt Collar

* Felt collar not included and must be ordered separately.

** As required.

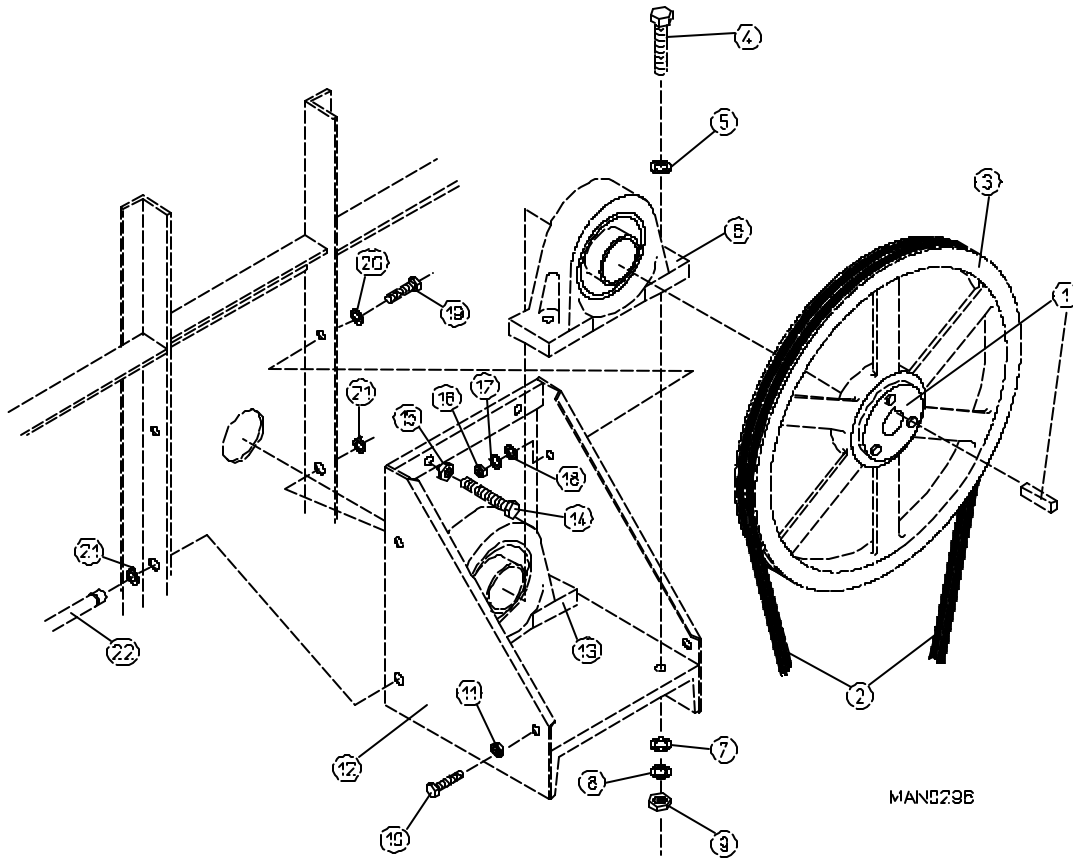

Illus. No.	Part No.	Qty.	Description
1	101137	1	2-1/4" SFX Bushing
2*	100135	2	AP74 "V" Belt
3	101136	1	AD-120 20" Basket Pulley
4	150602	4	5/8-11 x 3" Hex Head Machine Bolt
5	153016	4	5/8" Flat Washer
6	100204	1	2-1/4" Pillow Block Bearing
7	153016	4	5/8" Flat Washer
8	153015	4	5/8" Lock Washer
9	152010	4	5/8-11 Hex Nut
10	150600	2	3/8-16 x 1-1/2" Hex Head Machine Bolt
11	152005	2	3/8-16 Hex Nut
12	801102	1	AD-120 Tumbler Bearing Mount Assembly (includes illus. nos. 4 through 13)
13	100204	1	2-1/4" Pillow Block Bearing
14	150603	2	1/2-13 x 3" Square Head Machine Bolt
15	152011	2	1/2-13 Hex Nut
16	152005	2	3/8-16 Hex Nut
17	153005	2	3/8" Lock Washer
18	153004	4	3/8" Flat Washer
19	150600	2	3/8-16 x 1-1/2" Hex Head Machine Bolt
20	153004	2	3/8" Retaining Ring
22	301810	1	AD-120 (5/8") Hinge Pin

* Replace in match sets (both belts).

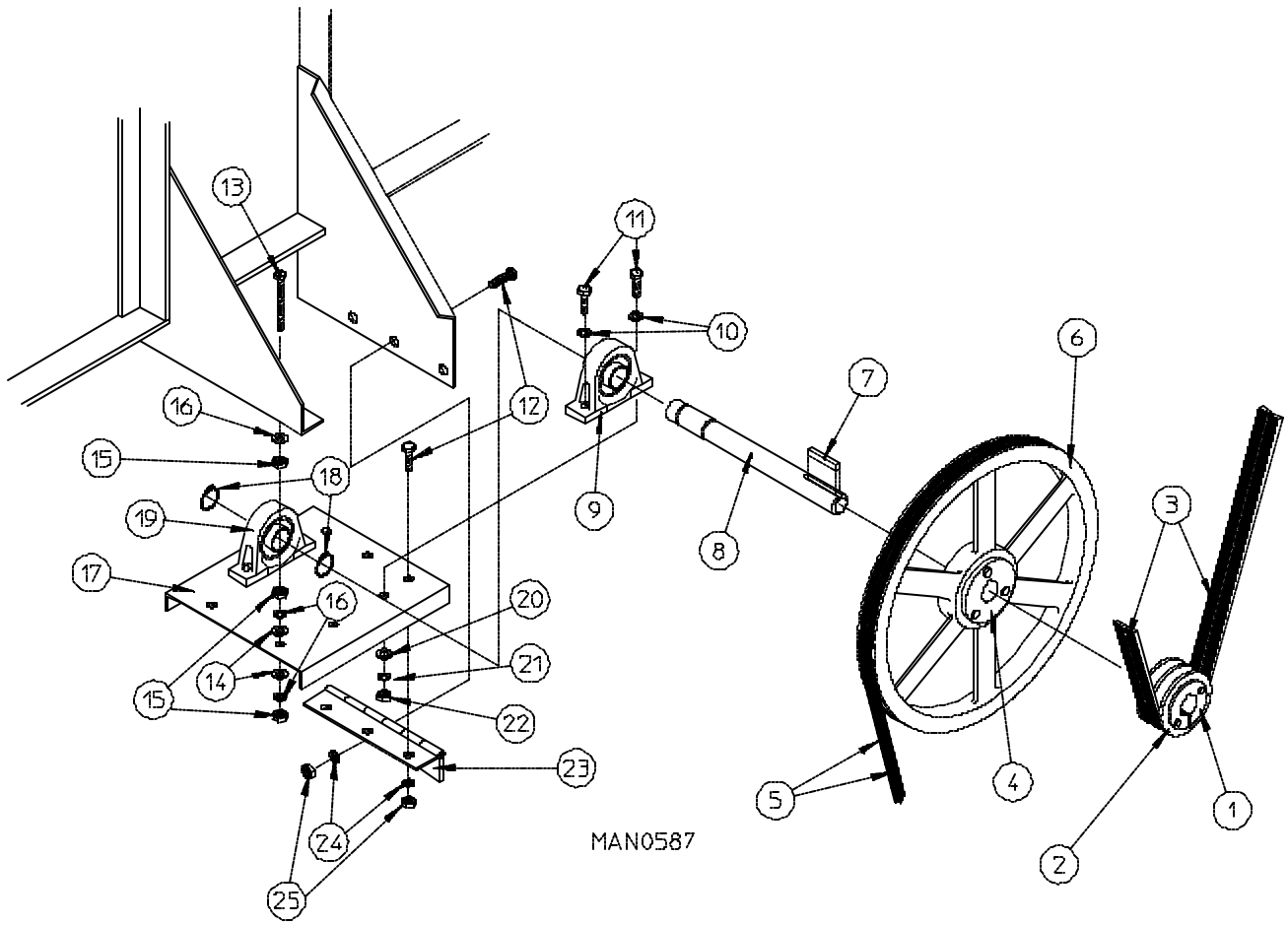

MAN0587

<u>Illus. No.</u>	<u>Part No.</u>	<u>Qty.</u>	<u>Description</u>
1	101110	1	1" Bushing
2	101113	1	2A3.0 Pulley
3*	100104	2	A68 "V" Belt
4	101107	1	1" SK Bushing
5*	100102	2	3V 740 "V" Belt
6	101112	1	19" Idler Pulley
7	100715	1	1/4" x 1/4" x 4-5/8" Key
8	301852	1	AD-120 (1") Idler Shaft ONLY
9	100205	1	1" Pillow Block Bearing
10	153004	4	3/8" Flat Washer
11	150600	4	3/8-16 x 1-1/2" Hex Head Machine Bolt
12	150512	6	1/4-20 x 1/2" Hex Head Machine Bolt
13	150509	2	5/16-18 x 3" Hex Head Machine Bolt
14	153001	6	5/16" Flat Washer
15	152004	6	5/16-18 Hex Nut
16	153002	4	5/16" Lock Washer
17	801001	1	AD-120 Idler Bearing Mount Assembly Complete (includes illus. nos. 7 through 11 and 17 through 25)
	311401	1	AD-120 Idler Bearing Mount ONLY
18	100800	2	1" Retaining Ring
19	100205	1	1" Pillow Block Bearing
20	153004	4	3/8" Flat Washer
21	153005	4	3/8" Lock Washer
22	152005	4	3/8-16 Hex Nut
23	103005	1	AD-120 Idler Adjustment Hinge ONLY
24	153007	6	1/4" Lock Washer
25	152002	6	1/4-20 Hex Nut

* Replace in matched sets (both belts).

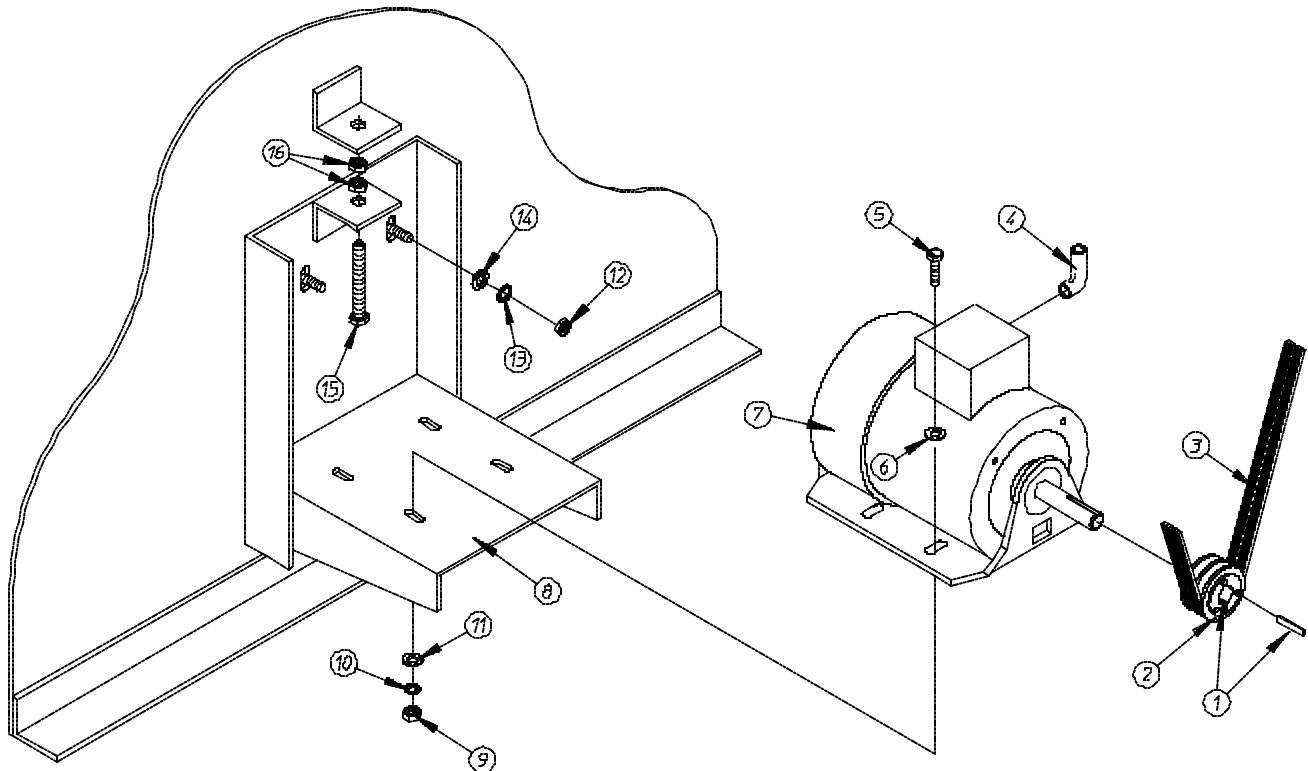

MAN0329

<u>Illus. No.</u>	<u>Part No.</u>	<u>Qty.</u>	<u>Description</u>
1	101121	1	5/8" SK Bushing
2	101114	1	2.65" Pulley (for 60 Hz Models Only)
	101120	1	3.15" Pulley (for 50 Hz Models Only)
3*	100102	2	3V740 "V" Belt
4	120200	1	3/8" x 90° Connector
5	150501	4	5/16-18 x 3/4" Hex Head Machine Bolt
6	153001	4	5/16" Flat Washer
7	100029	1	3/4 HP 208/230/280/460v 50/60Hz/3Ø T.E.F.C. Motor (56Z frame)
8	800952	1	AD-120 Basket Motor Mount ONLY (56Z frame)
	800953**	1	AD-120 (60Hz) T.E.F.C. Basket Motor Mount Assembly Complete (includes illus. nos. 1, 2, and 4 through 11)
	800955**	1	AD-120 (50Hz) T.E.F.C. Basket Motor Mount Assembly Complete (includes illus. nos. 1, 2, and 4 through 11)
9	152004	4	5/16-18 Hex Nut
10	153002	4	5/16" Lock Washer
11	153001	4	5/16" Flat Washer
12	152004	4	5/16-18 Hex Nut
13	153002	4	5/16" Lock Washer
14	153001	4	5/16" Flat Washer
15	150619	1	3/18-16 x 3" Hex Head Machine Bolt
16	152005	2	3/8-16 Hex Nut

IMPORTANT: For voltages higher than 460v, contact the factory for correct part number of motor or motor mount assembly.

* Replace in matched sets (both belts).

** Specify voltage when ordering.

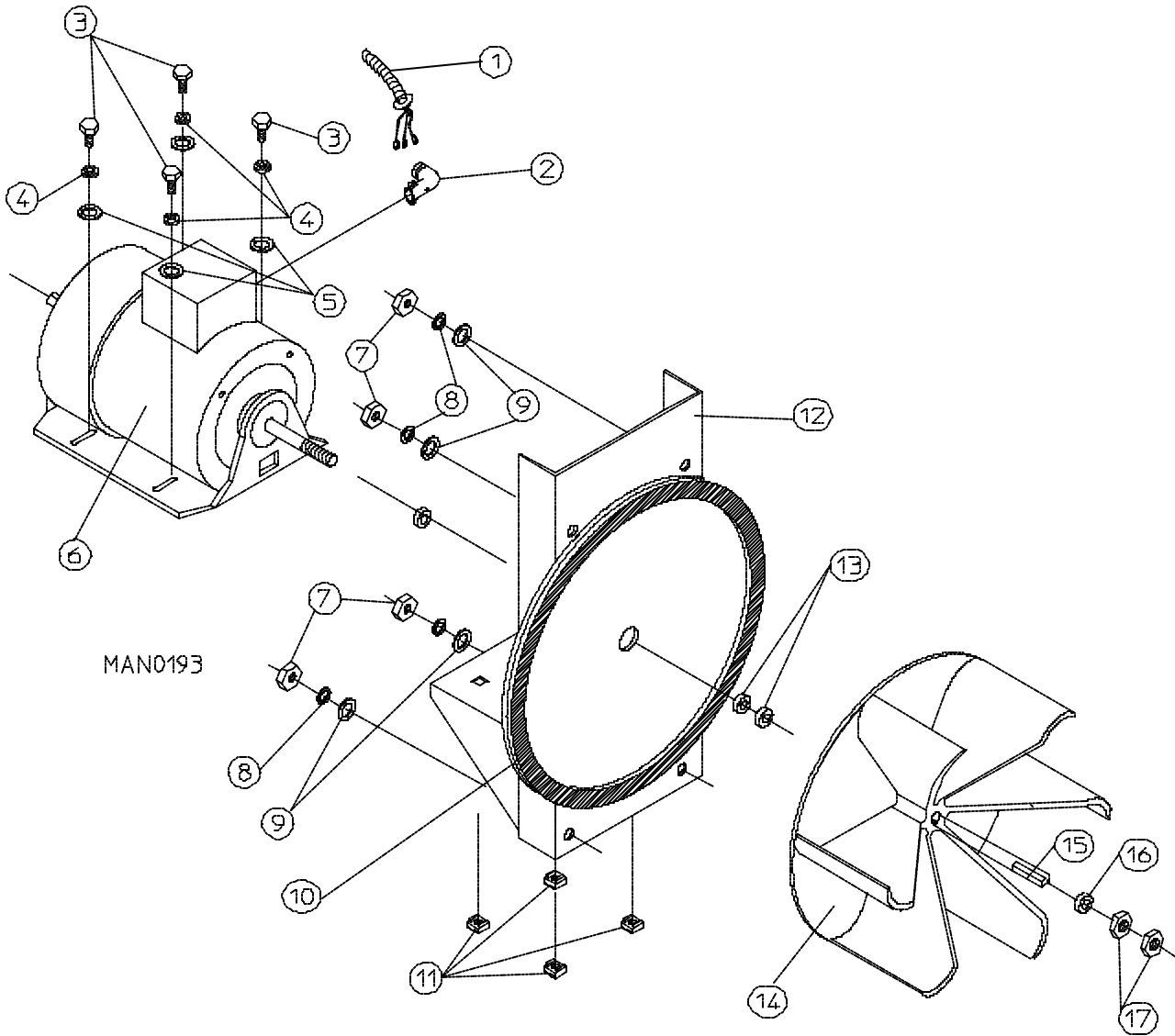

<u>Illus. No.</u>	<u>Part No.</u>	<u>Qty.</u>	<u>Description</u>
1	150501	4	5/16-18 x 3/4" Hex Head Machine Bolt
2	153002	4	5/16" Lock Washer
3	153001	4	5/16" Flat Washer
4*	100023	1	3HP 208/230/460v 50/60Hz 3Ø Motor (56Z frame)
5	152004	4	5/16-18 Hex Nut
6	153002	4	5/16" Lock Washer
7	153001	4	5/16" Flat Washer
8	117604	4	1/8" x 3/8" Neo. Sponge Tape
9	154000	4	5/16-18 Tinnerman Nut
10	800913	1	3HP Blower Motor Mount Assembly ONLY (56Z frame)
	803892*	1	3HP Blower Motor Mount Assembly Complete (includes illus. nos. 1 through 4, 8 through 12, 14, and 15)
11	153055	1	5/8" Motor Washer
12	881428	1	13" Magnesium Impellor
13	100705	1	3/16" x 3/16" x 1-3/8" Key
14	153055	**	5/8" Motor Washer
15	152006	2	1/2-20 Left-Hand Jam Nut

IMPORTANT: For voltages higher than 460v, contact the factory for correct part number of motor or motor mount assembly.

* Specify voltage when ordering.

** As required.

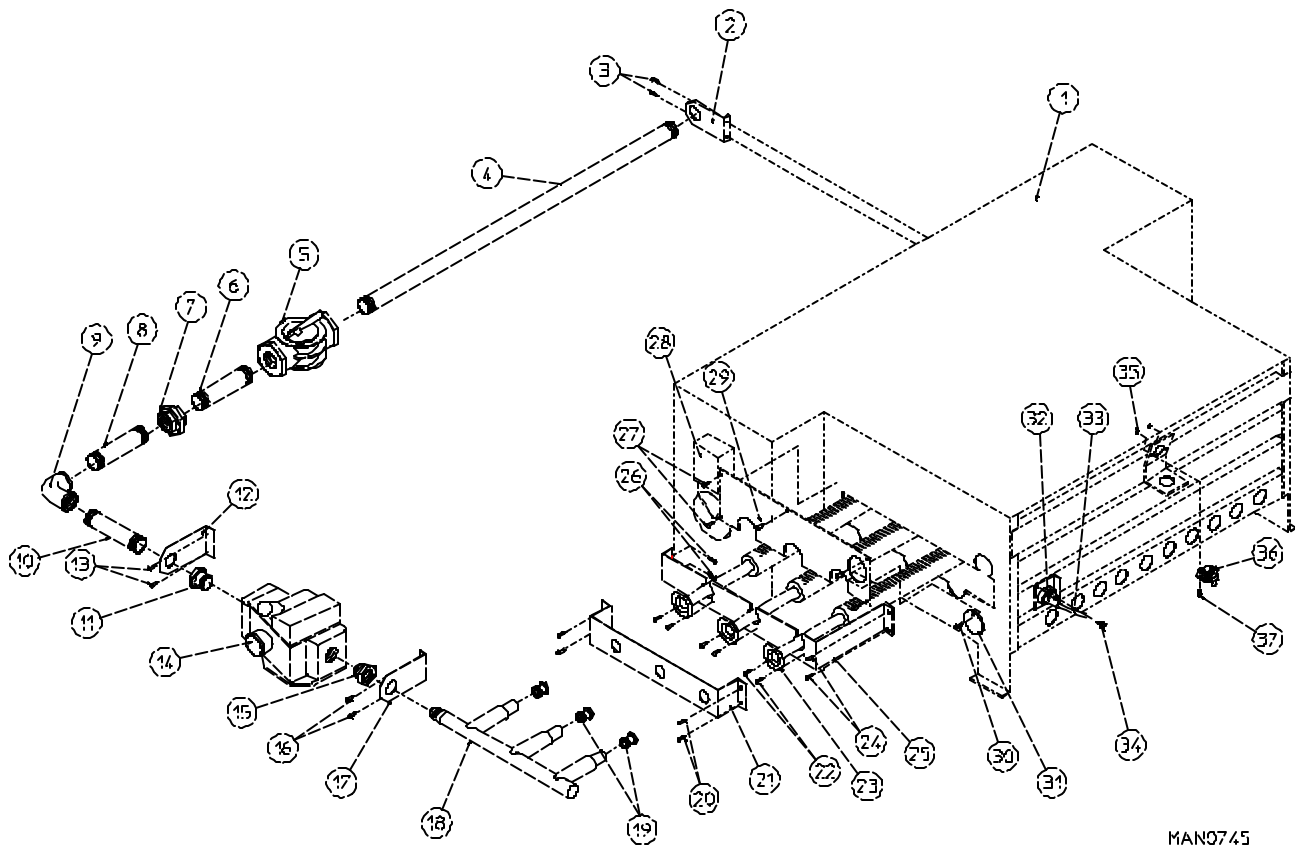

MAN0745

For Gas Models ONLY

<u>Illus. No.</u>	<u>Part No.</u>	<u>Qty.</u>	<u>Description</u>
1	820125*	1	ADG-120 DSI Burner Assembly Complete less Orifices (includes illus. nos. 1 through 18, and 20 through 36)
	820201	1	ADG-120 Burner Box ONLY
2	318364	1	ADG-120 Pipe Bracket
3	150415	2	#10-16 x 1/2" Phillips Right-Hand Crimptite Screw
4	142821	1	3/4" x 36" Pipe
5	141300	1	3/4" Union Shut-off
6	142701	1	3/4" Close Nipple
7	142601	1	3/4" Union
8	142701	1	3/4" Close Nipple
9	142504	1	3/4" x 90° Elbow
10	142709	1	3/4" x 2" Nipple
11	142916	1	1" to 3/4" Reducing Bushing
12	331291	1	ADG-120 Gas Valve Pipe Bracket
13	150415	2	#10-16 x 1/2" Phillips Right-Hand Crimptite Screw
14	140017	1	DSI 1" 24VAC Redundant (<u>natural gas</u>) Gas Valve
	140018	1	1" 24VAC Gas Valve L.P. (liquid propane) Conversion Kit
15	142911	1	1" to 1/2" Reducing Bushing
16	150415	2	#10-16 x 1/2" Phillips Right-Hand Crimptite Screw
17	331291	1	ADG-120 Gas Valve Pipe Bracket
18	141208	1	3-Port Manifold
19**	140832	3	#4 Burner Orifice (<u>natural gas</u>) ONLY
	140819	3	#30 Burner Orifice (<u>liquid propane gas</u>) ONLY
20	150415	4	#10-16 x 1/2" Phillips Right-Hand Crimptite Screw
21	331288	1	ADG-120 Manifold Support ONLY
22	150415	6	#10-16 x 1/2" Phillips Right-Hand Crimptite Screw
23	141110	3	ADG-120 Burner Tube ONLY
24	150415	2	#10-16 x 1/2" Phillips Right-Hand Crimptite Screw
25	331287	1	ADG-120 Burner Tube Support ONLY
26	150415	2	#10-16 x 1/2" Phillips Right-Hand Crimptite Screw
27	150415	6	#10-16 x 1/2" Phillips Right-Hand Crimptite Screw
28	-----	1	Sail Switch (see Sail Switch Assembly on page 25)
29	331289	1	ADG-120 Burner Box Cover Plate ONLY
30	150415	1	#10-16 x 1/2" Phillips Right-Hand Crimptite Screw
31	331290	1	ADG-120 Ignitor/Flame-Probe Sight Hole Disc ONLY
32	880325	1	ADG-120 Ignitor/Flame Probe Assembly Kit (includes high voltage [HV] wire and connector)
	305410	1	DSI Ignitor Gap Feeler Gauge ... Not Illustrated
33	880330	1	DSI Ignitor HV Wire/Connector ONLY
34	150415	2	#10-16 x 1/2" Phillips Right-Hand Crimptite Screw
35	151000	2	#6-32 Pal Nut
36	130401	1	330° Hi-Limit ONLY
37	150001	2	#6-32 x 1/2" Right-Hand Machine Screw
---	880491**	1	ADG-120 DSI L.P. Conversion Kit

* Orifices not included and must be ordered separately.

** Consult factory for elevations over 2,000 feet.

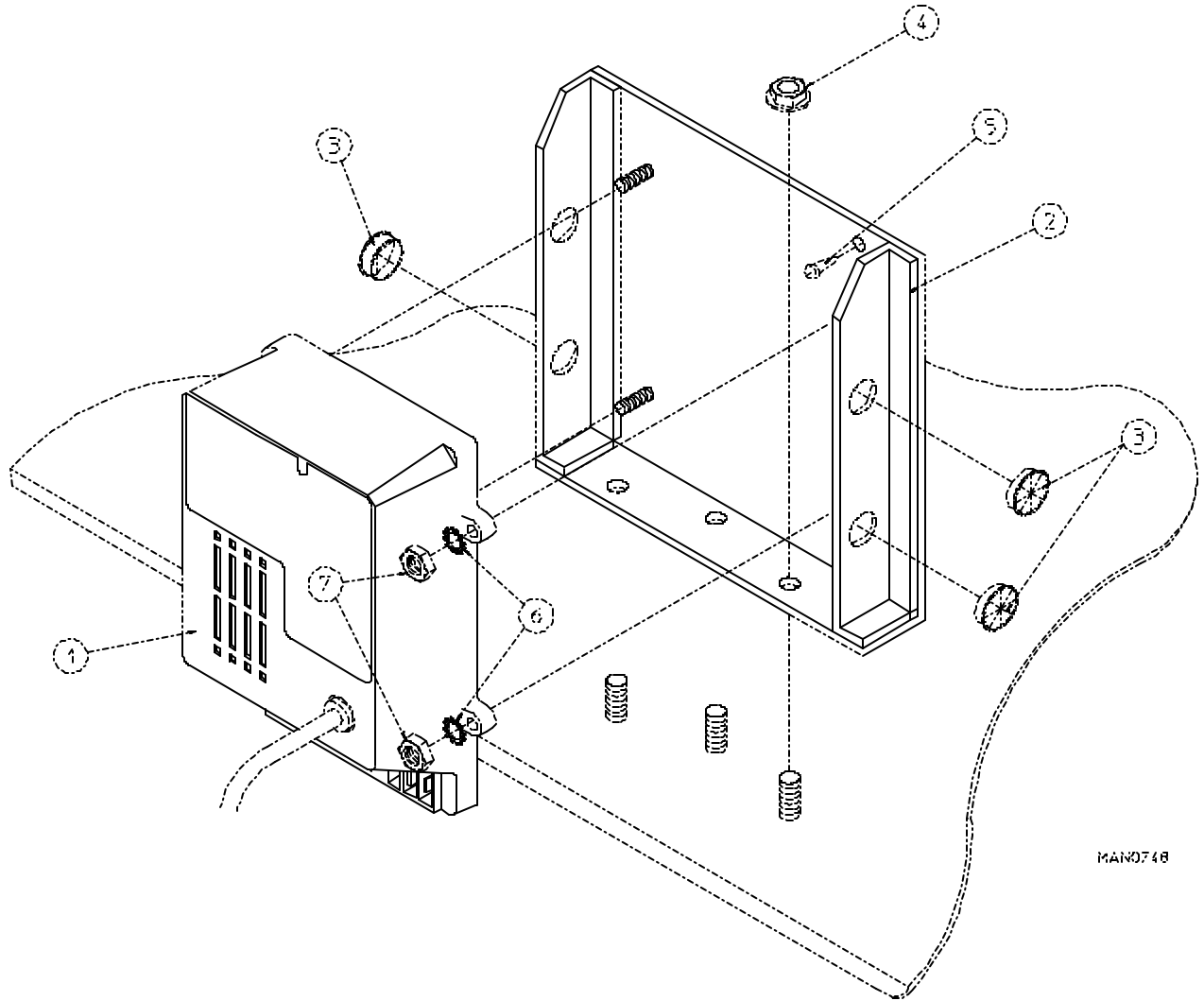

MAN0748

<u>Illus. No.</u>	<u>Part No.</u>	<u>Qty.</u>	<u>Description</u>
1	128926	1	DSI Module ONLY 50/60 Hz
2	820100	1	ADG-120 DSI Module Mount Assembly ONLY
3	121400	3	Universal Bushing
4	152014	3	1/4-20 Free Spin Wash Nut
5	150301	1	#8-18 x 7/16" Phillips Pan Head TEK Screw
6	153010	4	#6 Star Washer
7	152000	4	#6-32 Hex Nut

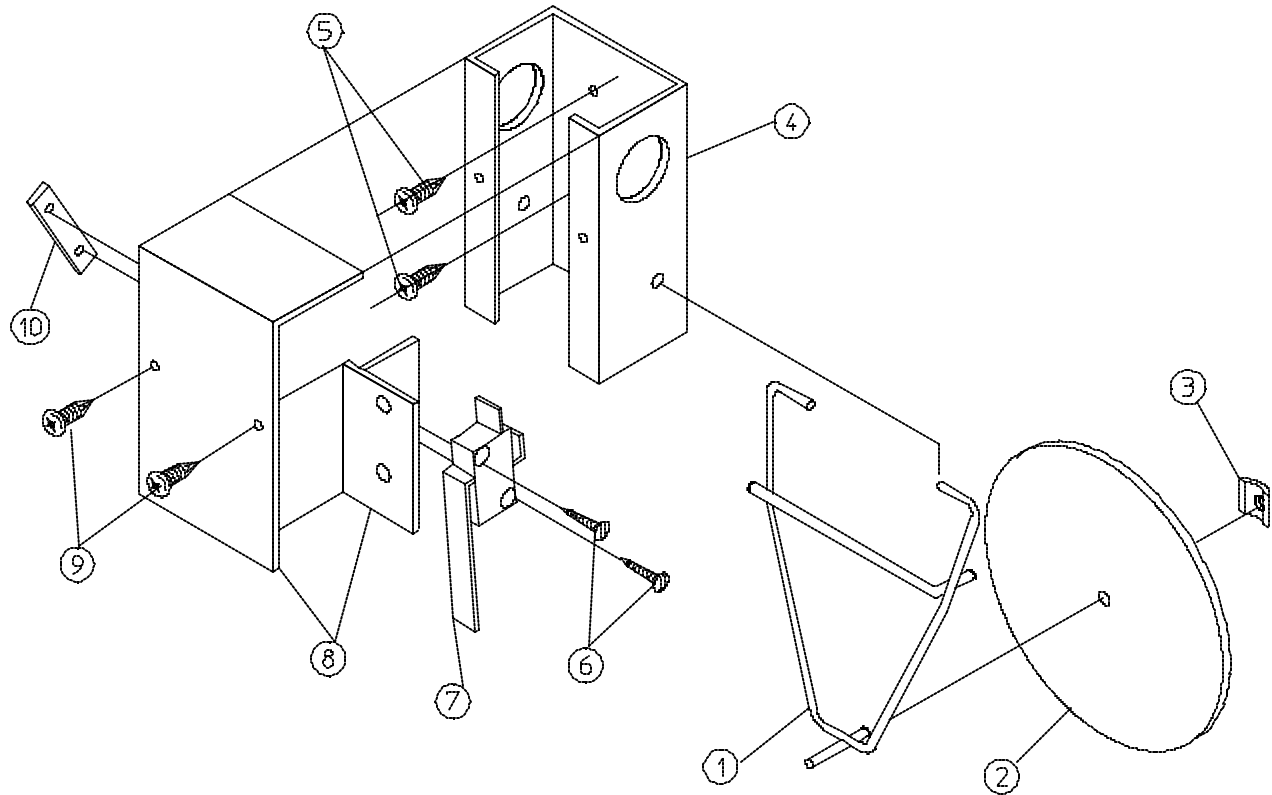

MAN0440

<u>Illus. No.</u>	<u>Part No.</u>	<u>Qty.</u>	<u>Description</u>
1	105500	1	Sail Switch Actuator Rod
2	319202	1	Sail Switch Damper (flat)
3	154002	1	1/8" Push-on Fastener
4	802800	1	Sail Switch Box with Cover and Bracket ONLY
	802801	1	Sail Switch Box Assembly Complete (includes illus. nos. 1 through 4 and 6 through 10)
5	150300	2	#10 x 1/2" Hex Washer TEK Screw
6	150303	2	#4 x 3/4" Pan Head "A" Machine Screw
7	122200	1	Sail Switch ONLY
8	802799	1	Sail Switch Box Cover and Bracket ONLY
9	150413	2	#10-16 X 1/2" Torx Crimpite Screw
10	154004	1	Twin Speed Nut

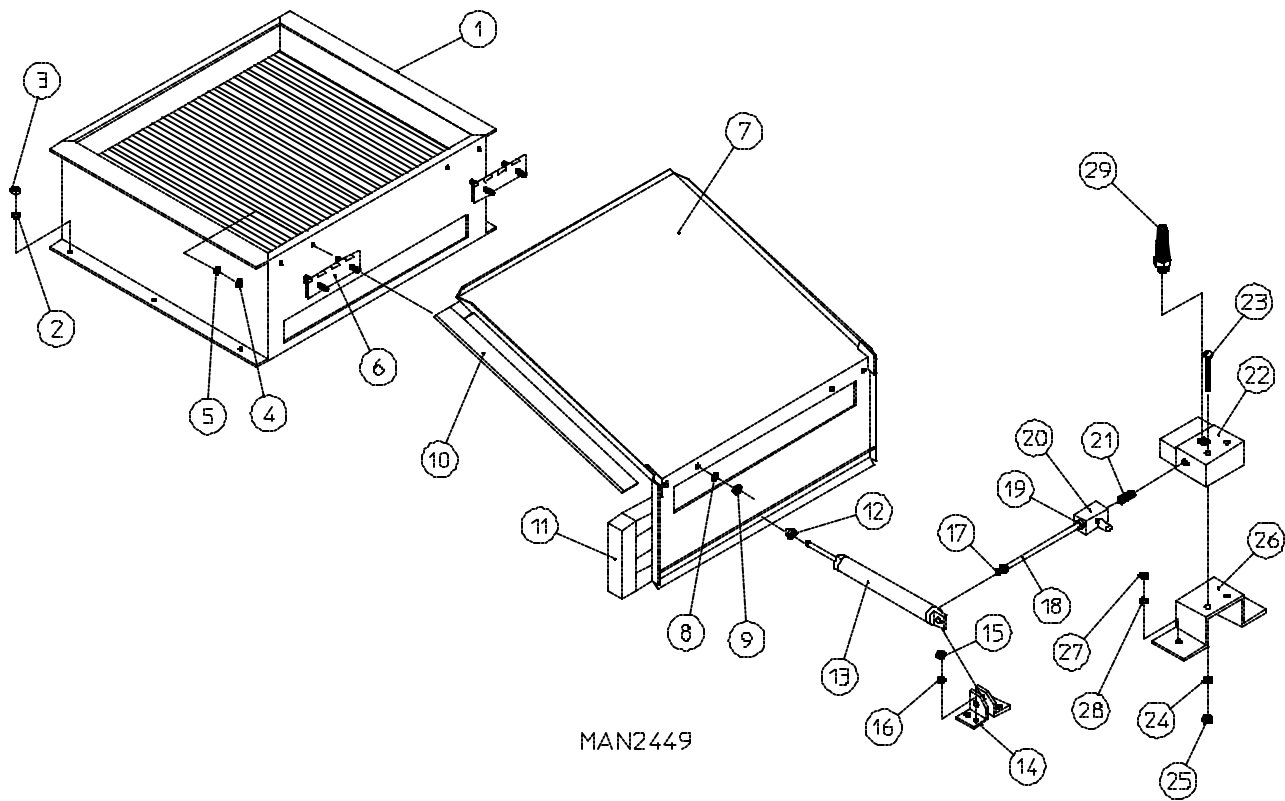

<u>Illus. No.</u>	<u>Part No.</u>	<u>Qty.</u>	<u>Description</u>
1	165012	1	ADS-120 Steam Coil Assembly
2	153002	6	5/16" Lock Washer
3	152004	6	5/16-18 Hex Nut
4	152002	4	1/4-20 Hex Nut
5	153007	4	1/4" Lock Washer
6	820321	2	ADS-120 Steam Damper Hinge Assembly
7	820320	1	ADS-120 Steam Damper Assembly
8	153007	4	1/4" Lock Washer
9	152002	4	1/4-20 Hex Nut
10	102376	3	ADS-120 Steam Damper Gasket (36" length)
11	102350	1	ADS-120 Steam Damper Foam (68-1/2" length)
12	151007	1	7/16-20 Stainless Steel Acorn Nut
13	100499	1	1-1/2" Bore x 3" Stroke Piston (for models mfd. as of February 21, 1991)
	100497	1	1-1/4" Bore x 3" Stroke Piston (for models mfd. prior to February 21, 1991)
14	100500	1	Piston Support Bracket (for models mfd. as of February 21, 1991)
	100492	1	Piston Support Bracket (for models mfd. prior to February 21, 1991)
15	152002	4	1/4-20 Hex Nut
16	153007	4	1/4" Lock Washer
17	100472	1	1/4" x 1/8" Connector
18	143110	1	1/4" Tubing (sold in feet)
19	100472	1	1/4" x 1/8" Connector
20	100496	1	1/8" Needle Valve
21	143238	1	1/8" Close Nipple
22	100498	1	3-Way Micro Valve - 24 VAC
23	150002	2	#6-32 x 1" Slotted Machine Screw
24	153010	2	#6 Star Washer
25	152000	2	#6-32 Hex Nut
26	330987	1	Micro Valve Support Bracket
27	152002	2	1/4-20 Hex Nut
28	153007	2	1/4" Lock Washer
29	100520	1	1/8" NPT Silencer (muffler)

For models mfd. prior to June 21, 1991

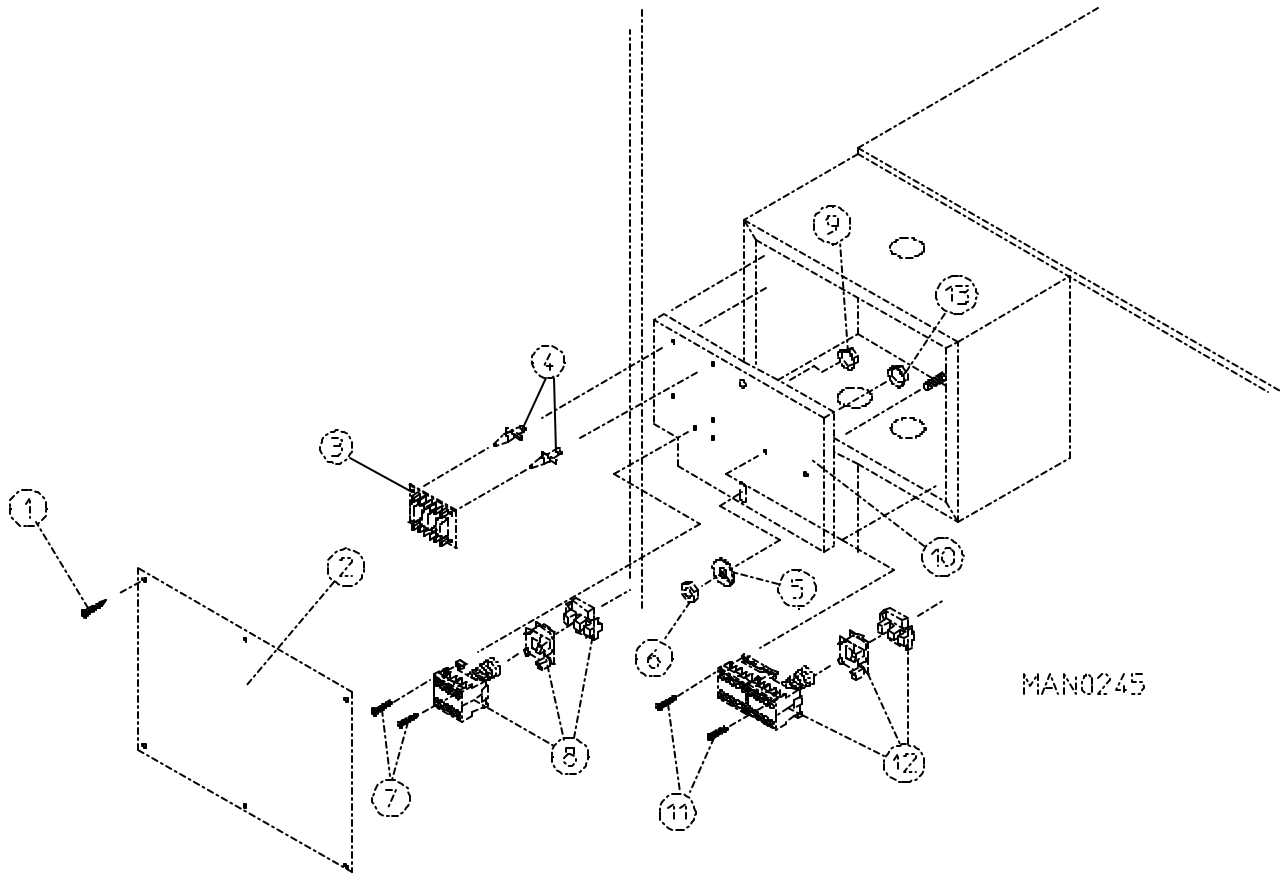

MAN0245

<u>Illus. No.</u>	<u>Part No.</u>	<u>Qty.</u>	<u>Description</u>
1	150301	6	#8-18 x 7/16" Phillips Pan Head TEK Screw
2	322808	1	Control Box Cover Plate ONLY
3	137060	1	Arc Suppressor Board (3)
4	137013	4	Nylon Standoff
5	153002	2	5/16" Lock Washer
6	152004	2	5/16-18 Hex Nut
7	150108	4	#8-32 x 1/2" Pan Head Machine Screw
8	132430	1	Impellor Contactor (24 volt)
	132432	1	Impellor Contactor Replacement Coil (24 volt)
9	151001	4	#8-32 Pal Nut
10	322807	1	Contactor Mounting Panel ONLY
11	150108	4	#8-32 x 1/2" Pan Head Machine Screw
12	132431	1	Reversing Contactor (24 volt)
	132432	1	Contactor Replacement Coil (24 volt)
13	151001	4	#8-32 Pal Nut

For models mfd. as of June 21, 1991

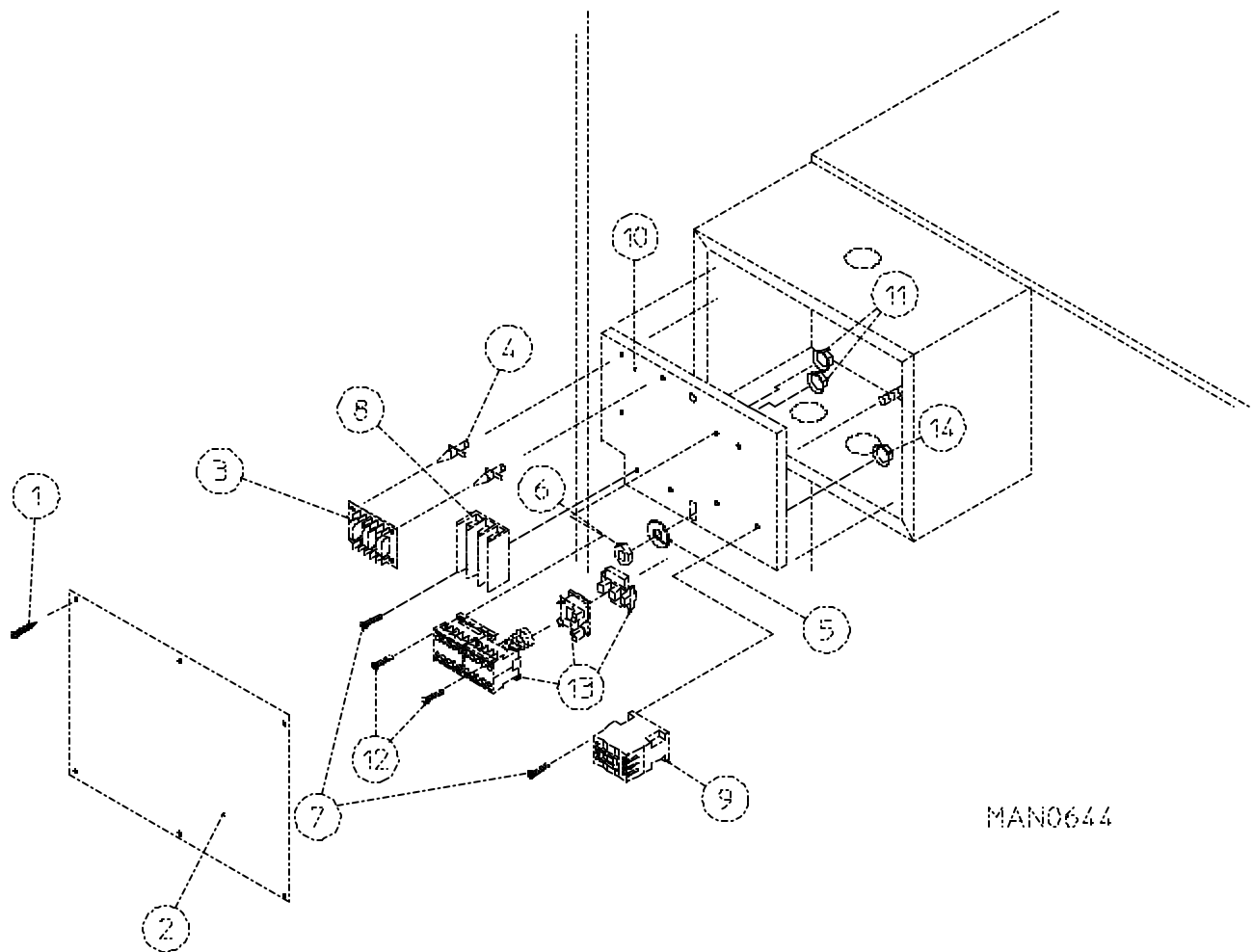

MAN0644

<u>Illus. No.</u>	<u>Part No.</u>	<u>Qty.</u>	<u>Description</u>
1	150301	6	#8-18 x 7/16" Phillips Pan Head TEK Screw
2	322808	1	Control Box Cover Plate ONLY
3	137060	1	Arc Suppressor Board (3)
4	137013	4	Nylon Standoff
5	153002	2	5/16" Lock Washer
6	152004	2	5/16-18 Hex Nut
7	150108	4	#8-32 x 1/2" Pan Head Machine Screw
8	120704	1	3-Position Power Distribution Block
9	132445	1	Impellor (blower) Contactor
10	322807	1	Contactor Mounting Panel ONLY
11	151001	4	#8-32 Pal Nut
12	150108	4	#8-32 x 1/2" Pan Head Machine Screw
13	132431	1	Reversing Contactor (24 volt)
	132432	1	Contactor Replacement Coil (24 volt)
14	151001	4	#8-32 Pal Nut

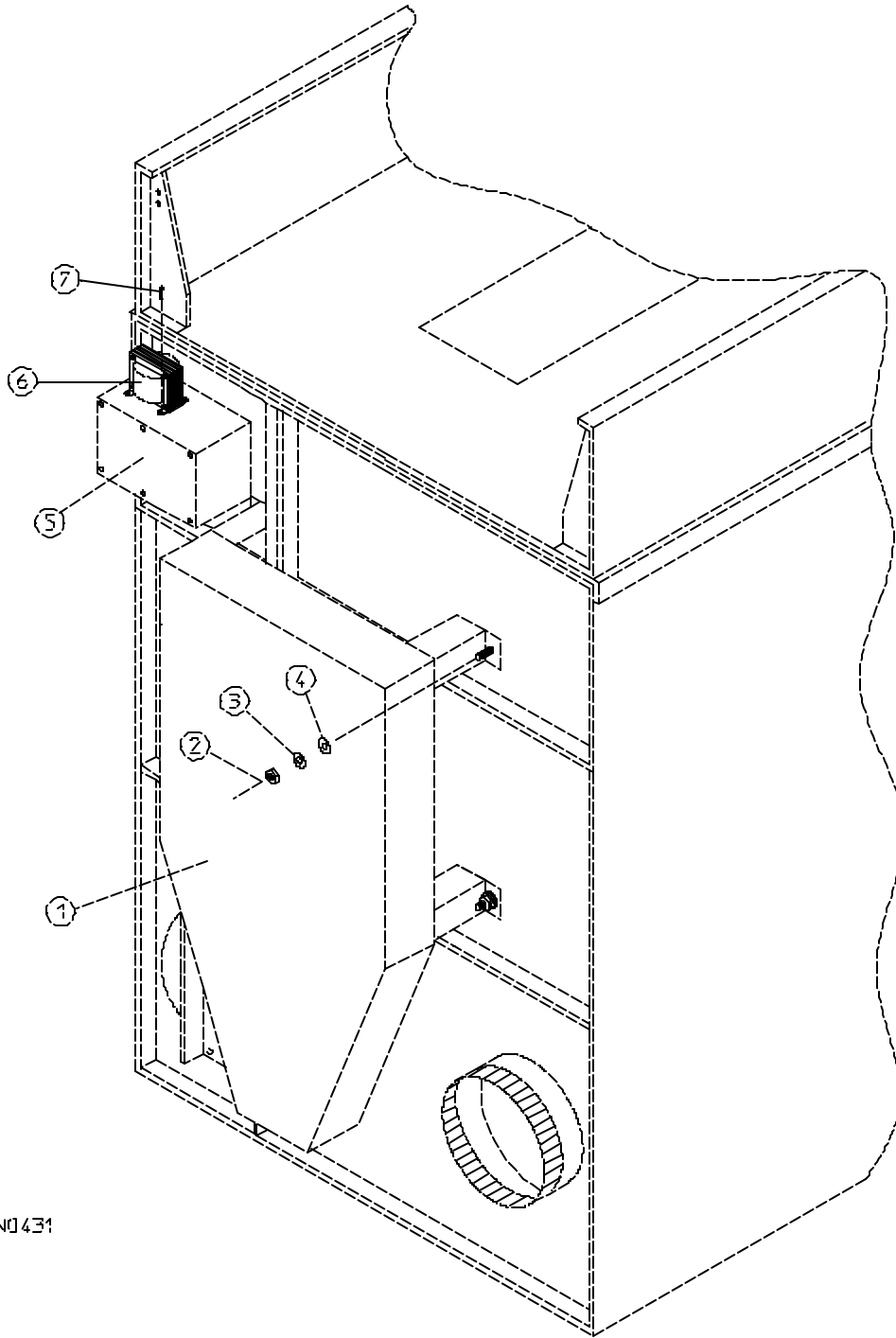

MAN0431

<u>Illus. No.</u>	<u>Part No.</u>	<u>Qty.</u>	<u>Description</u>
1	801509	1	AD-120 Back Guard Assembly
2	152005	4	3/8-16 Hex Nut
3	153005	4	3/8" Lock Washer
4	153004	4	3/8" Flat Washer
5	322808	1	Control Box Cover Plate ONLY
6	132008	1	240-480 Volt / 120-240 Volt Stepdown Transformer (.25 KVA)
	132011	1	380-600 Volt / 115-230 Volt Stepdown Transformer (.25 KVA)
7	150300	2	#10 x 1/2" Hex Washer TEK Screw

<u>Part No.</u>	<u>Description</u>
112027	“Water Washed Fabrics” Label
112040	“Lint Compartment” Label
112041	“Caution Exhausted” Label
112090	“Phase 4 OPL Program Location Summary” Label
117505	Aluminum Duct Tape (sold in feet)
120100	3/8” Straight (BX) Connector
120300	3/8” x 45° (BX) Connector
120400	3/8” Red Jacket (BX) Insulator
120500	3/8” Jiffy Clip (BX Retainer Clip)
120600	3/8” Greenfield (BX)
120800	1/4” In-line Connector
120802	Red Butt Connector
120902	#74B Wire Nut
120903	Crimp-on Wire Nut
121014	1/4” Insulated (female) Terminal
121499	4” Harness Tie
121500	7” Harness Tie
121503	Harness Tie Mounting Clip
122804	Manometer (water column test gauge)
404502	White Brush-in-Cap Bottle Touch-Up Paint (0.6 oz bottle)
404506	Beige Brush-in-Cap Bottle Touch-Up Paint (0.6 oz bottle)
401010	#847 Adhesive For Felt Collar
880200	Electrical Terminal (assortment) Kit

ADC 450100 **1-** 10/22/91-100 **2-** 12/20/91-100 **3-** 07/31/92-100
4- 01/29/93-100 **5-** 02/22/94-100 **6*** 07/29/97-50

