



AD-120ES Parts Manual Phase 7

American Dryer Corporation
88 Currant Road
Fall River, MA 02720-4781
Telephone: (508) 678-9000 / Fax: (508) 678-9447
e-mail: techsupport@amdry.com
www.amdry.com

Retain This Manual In A Safe Place For Future Reference

American Dryer Corporation products embody advanced concepts in engineering, design, and safety. If this product is properly maintained, it will provide many years of safe, efficient, and trouble free operation.

ONLY qualified technicians should service this equipment.

OBSERVE ALL SAFETY PRECAUTIONS displayed on the equipment or specified in the installation manual included with the dryer.

The following “**FOR YOUR SAFETY**” caution **must be** posted near the dryer in a prominent location.

FOR YOUR SAFETY

Do not store or use gasoline or other flammable vapors and liquids in the vicinity of this or any other appliance.

POUR VOTRE SÉCURITÉ

Ne pas entreposer ni utiliser d'essence ni d'autres vapeurs ou liquides inflammables à proximité de cet appareil ou de tout autre appareil.

We have tried to make this manual as complete as possible and hope you will find it useful. **ADC** reserves the right to make changes from time to time, without notice or obligation, in prices, specifications, colors, and material, and to change or discontinue models.

Important

For your convenience, log the following information:

DATE OF PURCHASE _____ **MODEL NO.** AD-120ES

RESELLER'S NAME _____

Serial Number(s) _____

Replacement parts can be obtained from your reseller or the **ADC** factory. When ordering replacement parts from the factory, you can FAX your order to **ADC** at (508) 678-9447 or telephone your order directly to the **ADC** Parts Department at (508) 678-9000. Please specify the dryer **model number** and **serial number** in addition to the **description** and **part number**, so that your order is processed accurately and promptly.

The illustrations on the following pages may not depict your particular dryer exactly. The illustrations are a composite of the various dryer models. Be sure to check the descriptions of the parts thoroughly before ordering.

“IMPORTANT NOTE TO PURCHASER”

Information **must be** obtained from your local gas supplier on the instructions to be followed if the user smells gas. These instructions **must be** posted in a prominent location near the dryer.

Table of Contents

Control Door Assembly	3
Phase 7 OPL Microprocessor Control Panel Assembly	4
Front Door Assembly	5
Dual Timer Control Box Assembly	6, 7
Dual Timer “Tap Touch” Controls	8
Front Panel Assembly	9
Main Door Switch Assembly	10
Lint Drawer/Lint Drawer Switch Box Assemblies	
For Models Mfd. as of March 25, 2003	11
Lint Drawer/Lint Drawer Switch Box Assemblies	
For Models Mfd. prior to March 25, 2003	12
Lint Door Assembly	13
Microprocessor Controller (Computer) Temperature Sensor Bracket Assembly	14
Dual Timer Temperature Sensor Bracket Assembly	15
Basket (Tumbler)/Support Assemblies	16, 17
Basket (Tumbler) Bearing Mount Assembly	18, 19
Idler Bearing Mount Assembly	20, 21
Basket (Tumbler) Drive Motor Mount Assembly	22, 23
Blower Motor Mount Assembly	24, 25
Direct Spark Ignition (DSI) Burner Assembly	
For Gas Models Only	26, 27
Direct Spark Ignition (DSI) Module Assembly	28, 29
Electric Oven Assembly	
For Electric Models Only	30, 31
Electric Oven Relay Box Assembly	
208-240 VAC 3 ϕ 50/60 Hz	32
Electric Oven Relay Box Assembly	
380-416/480 VAC 3 ϕ 50/60 Hz	33
Sail Switch Assembly	34
Steam Damper Assembly	
For Steam Models Only	35
Microprocessor Reversing Contactor Mounting Panel Assembly (Gas and Steam)	
208-240 Volt 3 ϕ	
For Models Mfd. prior to February 3, 2002	36

Microprocessor Reversing Contactor Mounting Panel Assembly (Gas and Steam)	
380-416 Volt 3 ϕ	
For Models Mfd. prior to February 3, 2002	37
Microprocessor Reversing Contactor Mounting Panel Assembly (Electric)	
208-240 Volt 3 ϕ	
For Models Mfd. prior to February 2003	38
Microprocessor Reversing Contactor Mounting Panel Assembly (Electric)	
380-480 Volt 3 ϕ	
For Models Mfd. prior to February 2003	39
Microprocessor Reversing Contactor Mounting Panel Assembly (Electric)	
208-240 Volt 3 ϕ	
For Models Mfd. as of February 2003	40
Microprocessor Reversing Contactor Mounting Panel Assembly (Electric)	
380-480 Volt 3 ϕ	
For Models Mfd. as of February 2003	41
Microprocessor Reversing Contactor Mounting Panel Assembly (Gas and Steam)	
208-240 Volt	
For Models Mfd. as of February 3, 2003	42, 43
Microprocessor Reversing Contactor Mounting Panel Assembly (Gas and Steam)	
380-416 Volt	
For Models Mfd. as of February 3, 2003	44, 45
Microprocessor Reversing Contactor Mounting Panel Assembly (Gas and Steam)	
460-480 Volt	
For Models Mfd. as of February 25, 2003	46, 47
Electric Oven Component Application Listings	
For Electric Models Only	48
Electric Oven Power Distribution	
72 kW 208-240 VAC 3 ϕ 50/60 Hz	49
Electric Oven Power Distribution	
72 kW 380-416/440-480 VAC 3 ϕ 50/60 Hz	50
Electric Oven Power Distribution	
60 kW 380-416/480 VAC 3 ϕ 50/60 Hz	51
72 kW Electric Oven Assembly	52
60 kW Electric Oven Assembly	53
Extended Back Guard Assembly	54
S.A.F.E. Solenoid Assembly	55
S.A.F.E. Temperature Probe Assembly	56

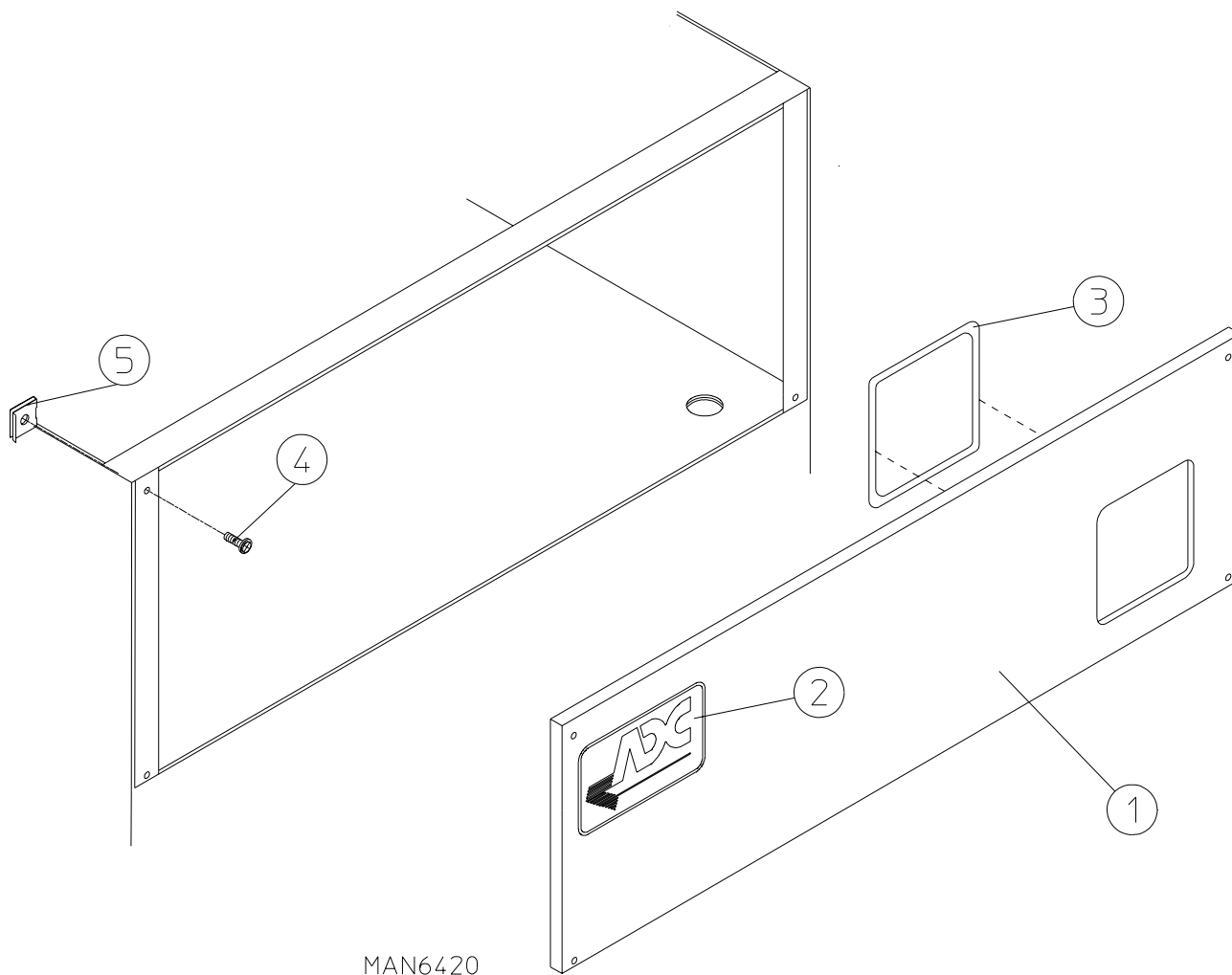

<u>Illus. No.</u>	<u>Part No.</u>	<u>Qty.</u>	<u>Description</u>
1	883765*	1	Control Door Assembly (for gas and electric models Only) (includes illus. nos. 1 and 3)
	883766*	1	Control Door Assembly (for steam models Only) (includes illus. nos. 1 and 3)
2	112360	1	ADC Logo
3	117604	1	1/8" x 3/8" Noise Suppression Tape
4	150314	4	#10-32 x 1/2" TORX Screw
5	154011	4	#10-32 Multi-Thread U-Nut

* Specify color when ordering.

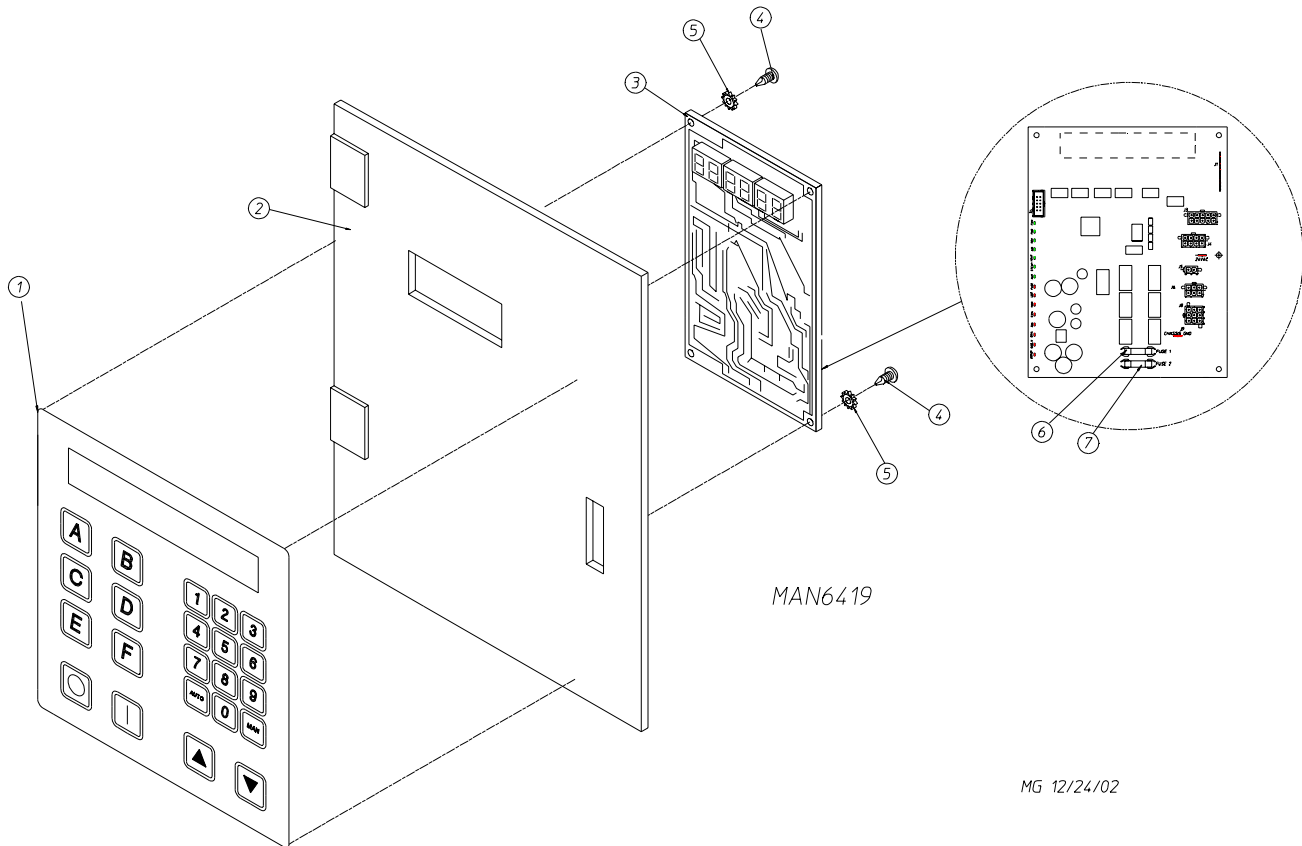

<u>Illus No.</u>	<u>Part No.</u>	<u>Qty.</u>	<u>Description</u>
1	112571	1	Phase 7 OPL Keyboard
2	850979	1	Phase 7 OPL Microprocessor Controller (computer) Panel ONLY
3	883732	1	Phase 7 OPL Reversing Microprocessor Controller (computer) Control Panel Assembly Complete (includes illus. nos. 1 through 7)
	883745	1	Phase 7 OPL Microprocessor Controller (computer) ONLY
4	150005	4	#6-32 x 3/4" Phillips Round Head Machine Screw
5	153010	4	#6 Star Washer
6	136016	1	5-amp Fuse
7	136097	1	500-mA (Slo-Blo) Fuse

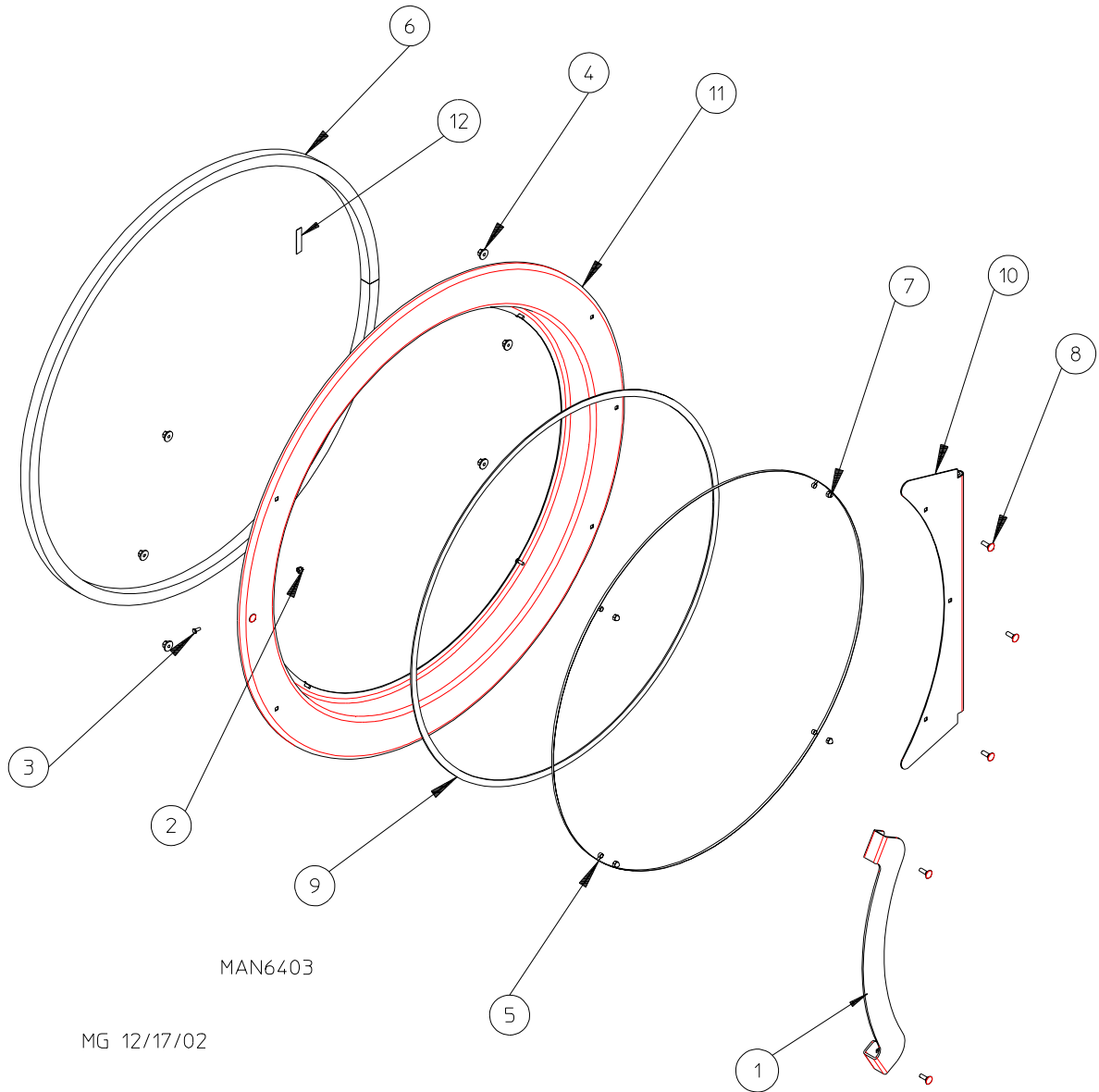

<u>Illus. No.</u>	<u>Part No.</u>	<u>Qty.</u>	<u>Description</u>
1	883252	1	Large Black Main Door Handle
2	151010	1	#10-32 Hex Acorn Lock Nut (black)
3	150120	1	#10-32 x 0.4375 Door Latch Screw
4	152014	6	1/4-20 Free Spin Wash Nut
5	102214	1	30" Door Glass
6	102357	1	Large Steel Door Gasket
7	151013	4	#10-32 Acorn Nut (black)
8	150683	6	1/4-20" x 5/8" Carriage Bolt
9	102361	1	3/32" x 1/2" Black Gasket Tape
10	835056	1	Door Hinge
11	835057	1	Cold Rolled Steel (CRS) Door Ring Assembly
12	110006	2"	1/2" Black Strapping Tape
	883083	1	Black Large Cold Rolled Steel (CRS) Main Door Assembly (includes illus. nos. 1 through 12)

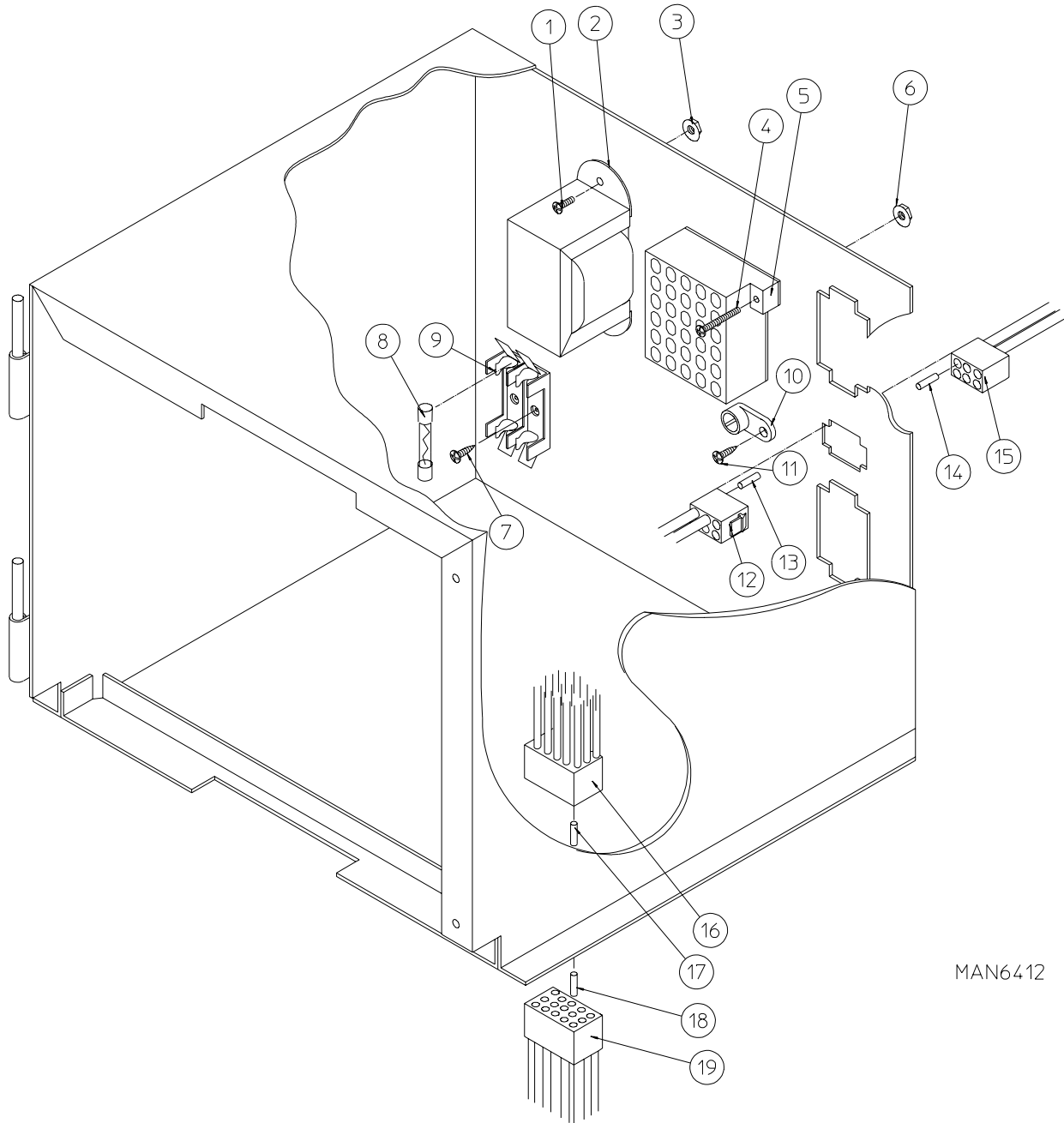

MAN6412

<u>Illus. No.</u>	<u>Part No.</u>	<u>Qty.</u>	<u>Description</u>
1	150100	2	#8-32 x 1/2" Phillips Round Head Machine Screw
2	141403	1	24 VAC Transformer - 50/60 Hz (for gas models and steam models Only)
3	151001	2	#8-23 Pal Nut
4	150002	2	#6-32 x 1" Phillips Round Head Machine Screw
5	120715	1	30-Position Terminal Block
6	151000	2	#6-32 Pal Nut
7	150102	2 or 3	#8 x 3/8" Phillips Round Head TEK Screw
8	136057	2	1/2-amp (Slo-Blo) Fuse ONLY
	182453	1	Amp (fast acting) Fuse (for electric models Only)
9	136008	2 or 3	Fuse Block/Strip ONLY
10	150413	1	#10-16 x 1/2" Torx Crimptite Screw
11	121010	1	L-70 Ground Lug
12	122631	1	6-Pin Connector ONLY
13	122705	*	Socket Terminal ONLY
14	122704	*	Pin Terminal ONLY
15	122630	1	6-Pin Connector ONLY
	137025	1	6/15-Position Strain Relief...Not Illustrated
16	122625	1	15-Pin Connector ONLY
17	122704	12	Pin Terminal ONLY
18	122705	12	Socket Terminal ONLY
19	122626	1	15-Pin Socket Connector ONLY
---	122801	1	Pin/Socket Extraction Tool

* As required (either 2 or 3).

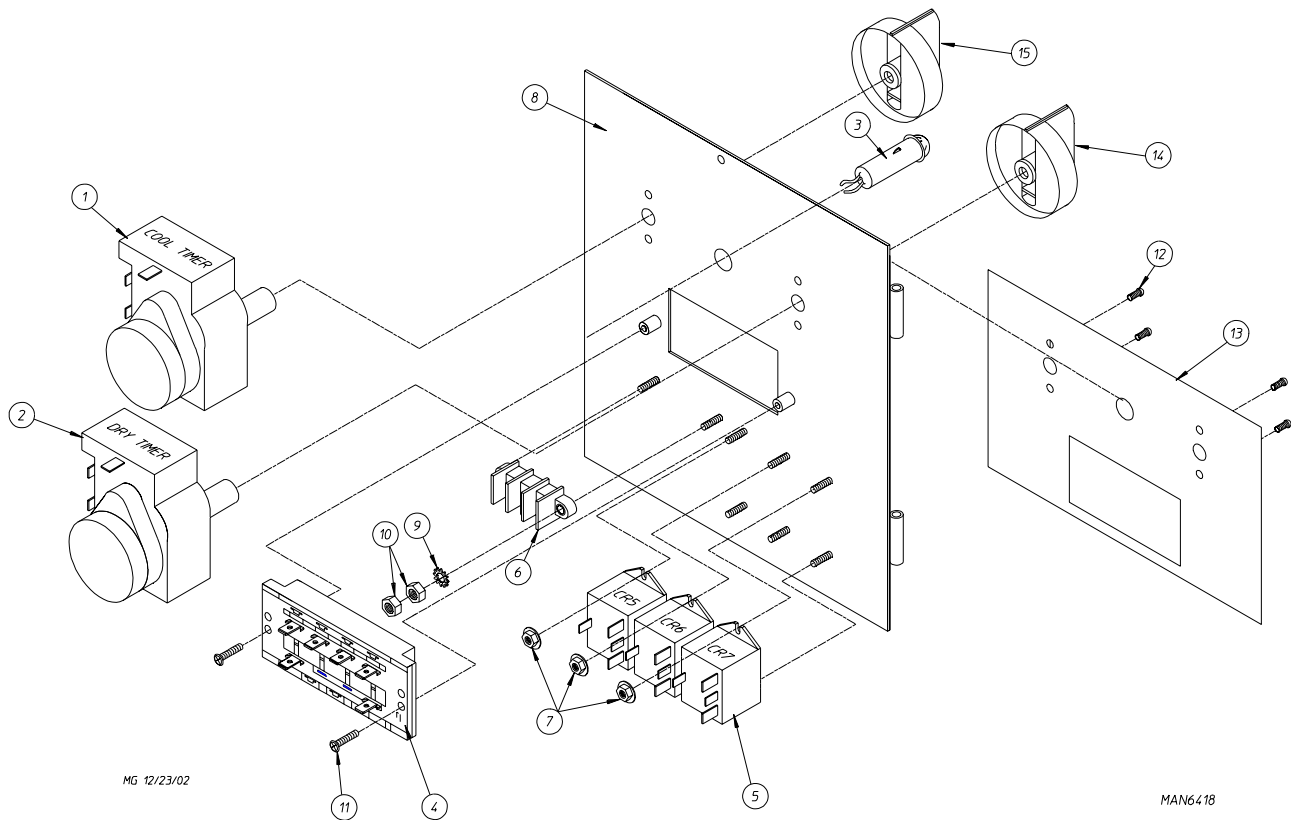

<u>Illus. No.</u>	<u>Part No.</u>	<u>Qty.</u>	<u>Description</u>
1	124030	1	15 Minute Timer - 24 VAC
2	124025	1	60 Minute Timer - 24 VAC
3	824175	1	Red Pilot Light - 24 VAC
4	122301	1	"Tap Touch" Switch
5	131932	3	Relay SPST 24 Volt
6	120708	1	Terminal Closed Block
7	151000	6	#6-32 Pal Nut
8	824067	1	Dual Timer Panel ONLY
9	153010	2	#6 Star Washer
10	152000	2	#6-32 Hex Nut
11	150207	2	#10-24 x 1/2" Phillips Pan Head Machine Screw
12	150110	4	#8-32 x 1/4" Phillips Round Head Machine Screw
13	112563	1	Dual Timer Panel Overlay
14	124104	1	Pure Touch Knob with Red Pointer
15	124105	1	Pure Touch Knob with Blue Pointer
	824296	1	Dual timer Panel Complete Assembly (including illus. nos. 1 through 15)

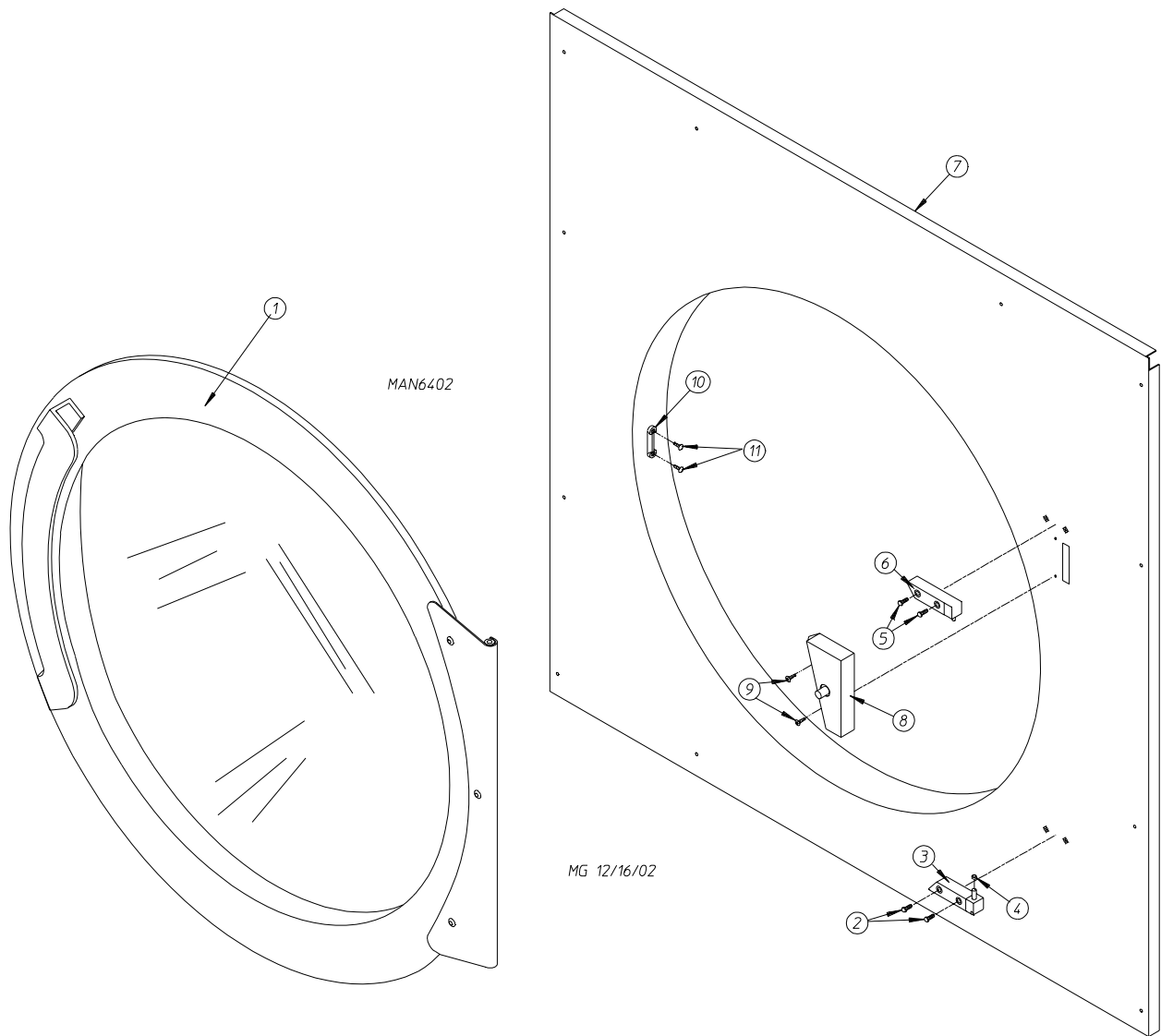

<u>Illus. No.</u>	<u>Part No.</u>	<u>Qty.</u>	<u>Description</u>
1	883083	1	Black Cold Rolled Steel (CRS) Main Door Assembly
2	150445	2	Socket Cap Screw (black)
3	170331	1	Bottom Hinge Block
4	153031	2	Nylon Washer
5	150445	2	Socket Cap Screw (black)
6	170329	1	Top Hinge Block
7	851081	1	Front Panel Assembly for Cold Rolled Steel (CRS) Door
8	801786	1	Main Door Switch and Housing
9	150301	2	#8 x 7/16" Phillips Head TEK Screw
10	170330	1	Friction Door Latch
11	154215	2	5/32" x 1/4" Rivet

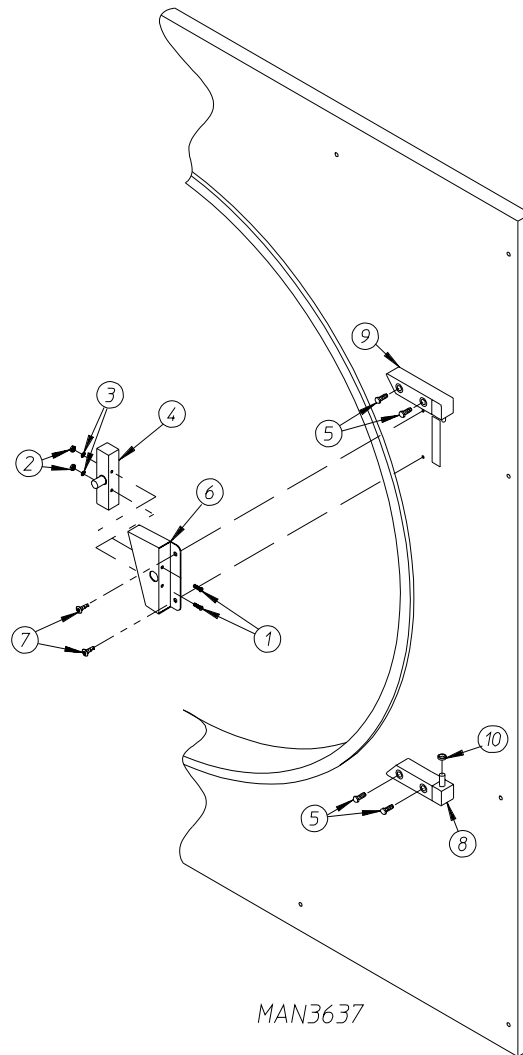

<u>Illus. No.</u>	<u>Part No.</u>	<u>Qty.</u>	<u>Description</u>
1	150006	2	#6-32 x 7/8" Phillips Pan Head Machine Screw
2	152013	2	#6-32 Hex Nut
3	153010	2	#6 Star Washer
4	137005	1	Single-Pole Door Switch
5	150445	4	1/4-20 x 3/4" Socket Head Cap Screw
6	881687	1	Main Door Switch Housing ONLY (white)
	881695	1	Main Door Switch Housing ONLY (blue)
	881702	1	Main Door Switch with Housing Assembly (white) (includes illus. nos. 1 through 4 and 6)
	881700	1	Main Door Switch with Housing Assembly (blue) (includes illus. nos. 1 through 4 and 6)
7	150443	2	1/4-20 x 3/4" Stainless Steel Cap Screw
8	881441	1	Bottom Hinge Block (white)
	881735	1	Bottom Hinge Block (blue)
9	881440	1	Top Hinge Block (white)
	881736	1	Top Hinge Block (blue)
10	153031	1	Nylon Washer

For Models Mfd. as of March 25, 2003

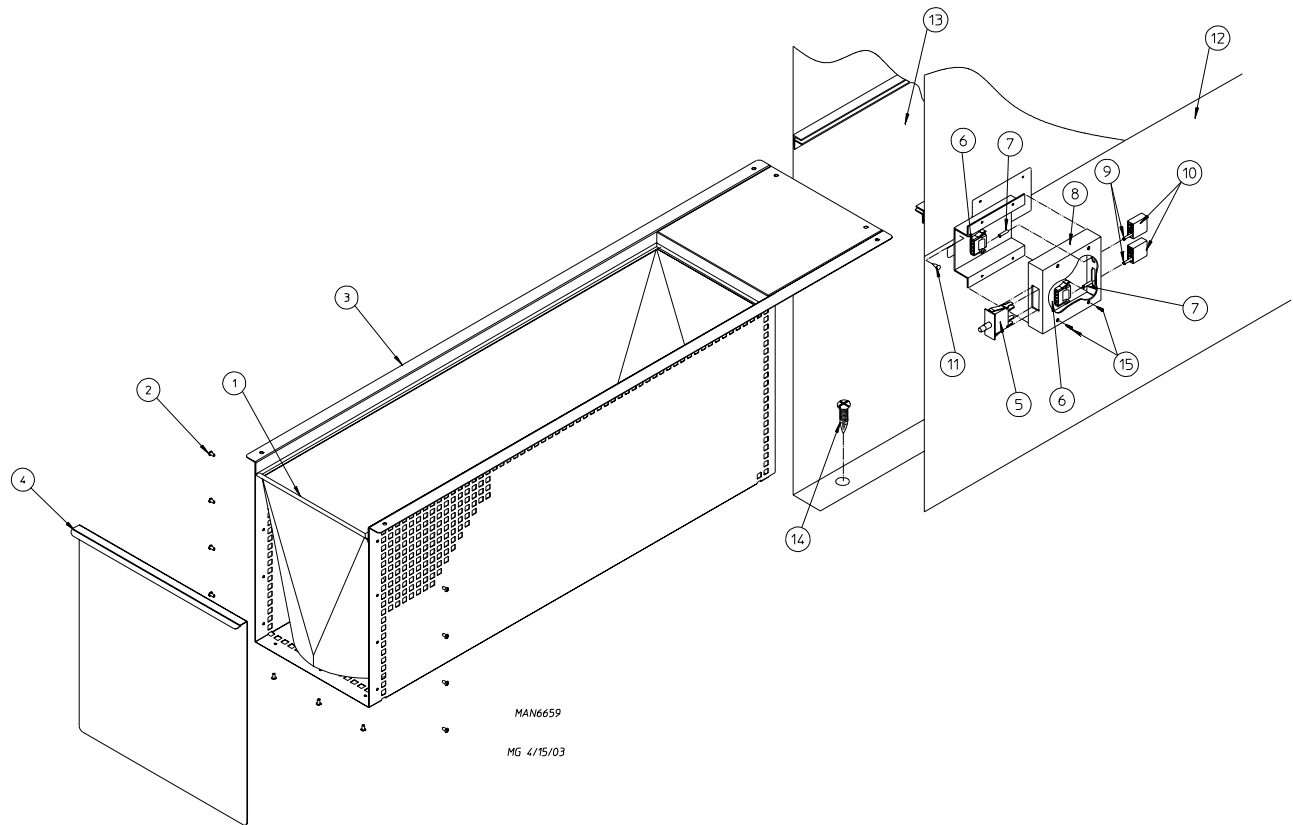

<u>Illus. No.</u>	<u>Part No.</u>	<u>Qty.</u>	<u>Description</u>
1	108209	1	Lint Bag
2	154211	11	Button Head Rivet
3	850949	1	Lint Basket
4	801137	1	Lint Drawer Handle
	801138	1	Stainless Steel Lint Drawer Handle
	883828	1	Stainless Steel Lint Drawer Assembly (includes illus. nos. 2 through 4)
	883829	1	Lint Drawer Assembly (includes illus. nos. 2 through 4)
5	122116	1	Lint Drawer Switch ONLY
6	122605	1	4-Pin Socket Connector
7	122701	2	Socket Terminal ONLY
	122801	1	Pin/Socket Extraction Tool
8	882507	1	Lint Drawer Switch Box Assembly Complete (includes illus. nos. 6 through 8 and 15)
9	122700	2	Pin Terminal ONLY
10	122604	1	4-Pin Connector
11	150301	2	#8-18 x 7/16" Phillips Pan Head TEK Screw
12	319076	1	Right Hand Divider Panel
13	319077	1	Left Hand Divider Panel
14	150301	14	#8-18 x 7/16" Phillips Pan Head TEK Screw
15	150301	4	#8-18 x 7/16" Phillips Pan Head TEK Screw

For Models Mfd. prior to March 25, 2003

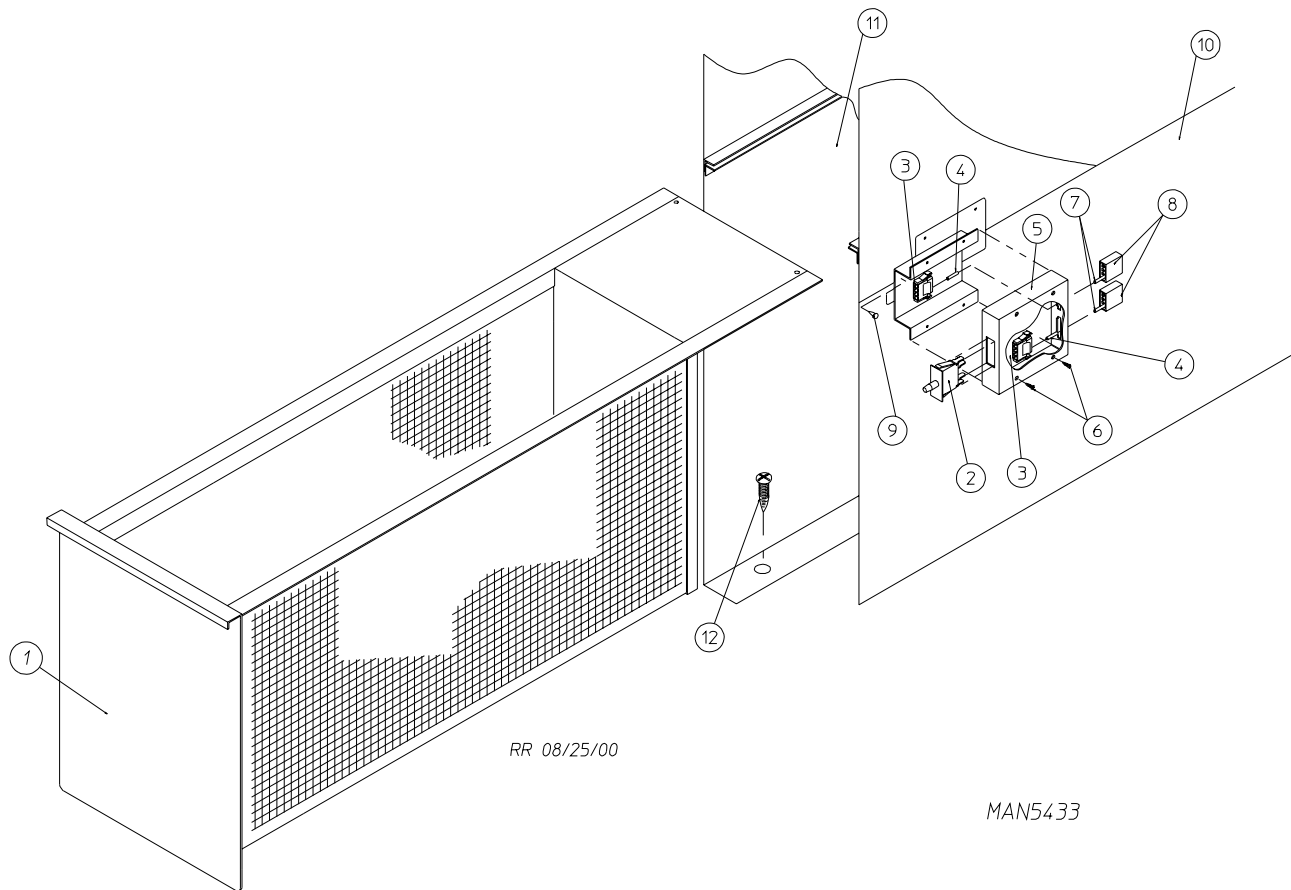

<u>Illus. No.</u>	<u>Part No.</u>	<u>Qty.</u>	<u>Description</u>
1	802106	1	Lint Basket Assembly
	802125	1	Stainless Steel Lint Basket Assembly
2	122116	1	Lint Drawer Switch ONLY
3	122605	1	4-Pin Socket Connector
4	122701	2	Socket Terminal ONLY
	122801	1	Pin/Socket Extraction Tool
5	882507	1	Lint Drawer Switch Box Assembly Complete (includes illus. nos. 3 through 6)
6	150301	4	#8-18 x 7/16" Phillips Pan Head TEK Screw
7	122700	2	Pin Terminal ONLY
8	122604	1	4-Pin Connector
9	150301	2	#8-18 x 7/16" Phillips Pan Head TEK Screw
10	319076	1	Right Hand Divider Panel
11	319077	1	Left Hand Divider Panel
12	150301	14	#8-18 x 7/16" Phillips Pan Head TEK Screw

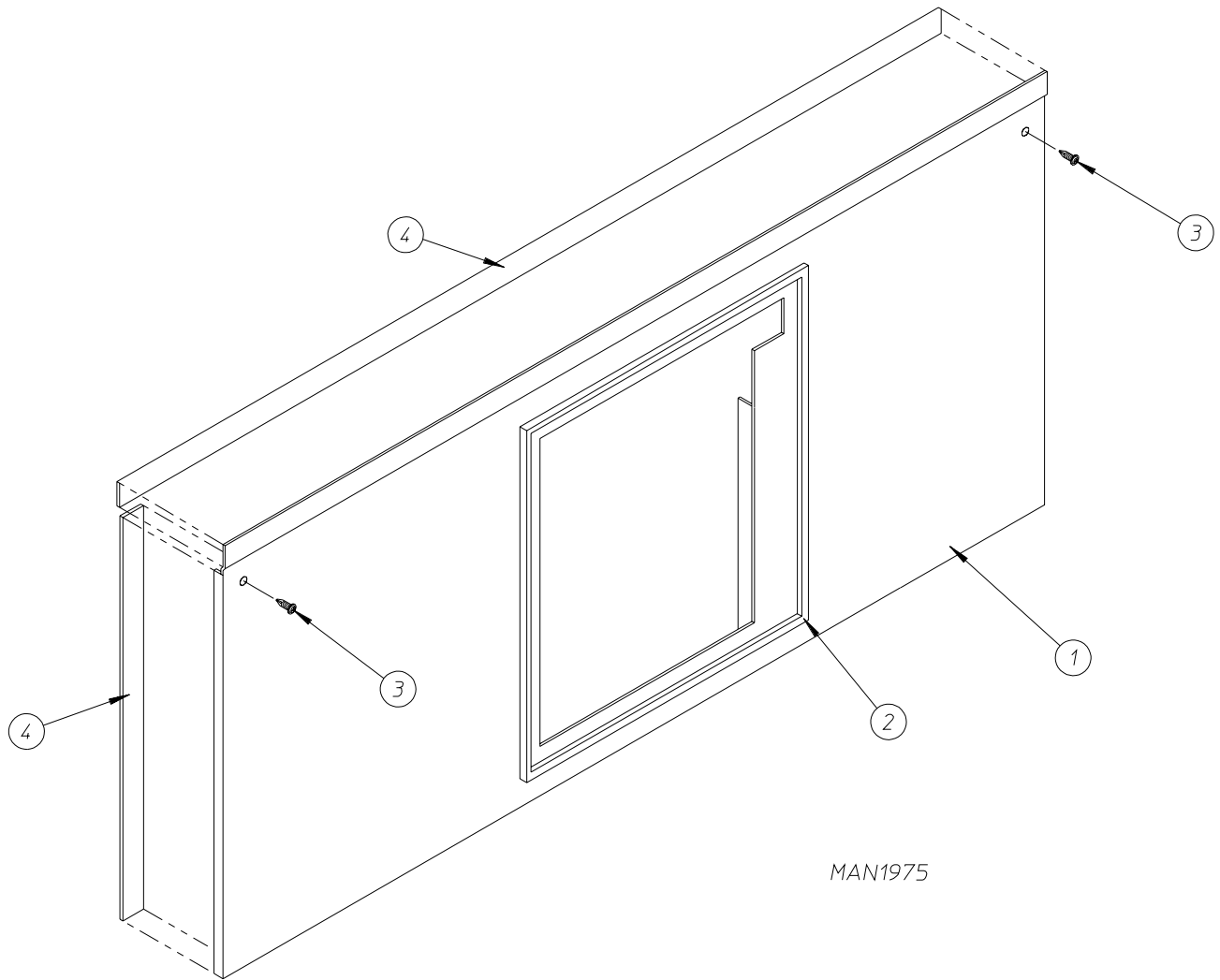

MAN1975

<u>Illus. No.</u>	<u>Part No.</u>	<u>Qty.</u>	<u>Description</u>
1	824256*	1	Lint Door Assembly (includes illus. nos. 1, 2, and 4)
	820021	1	Stainless Steel Lint Door Assembly
2	117602	5	Gasket (sold by the foot)
3	150309	5	#10-16 x 1/2" Hex Head TEK Crimptite Screw
4	117604	8	Neoprene Sponge Tape (sold by the foot)

* Specify color when ordering.

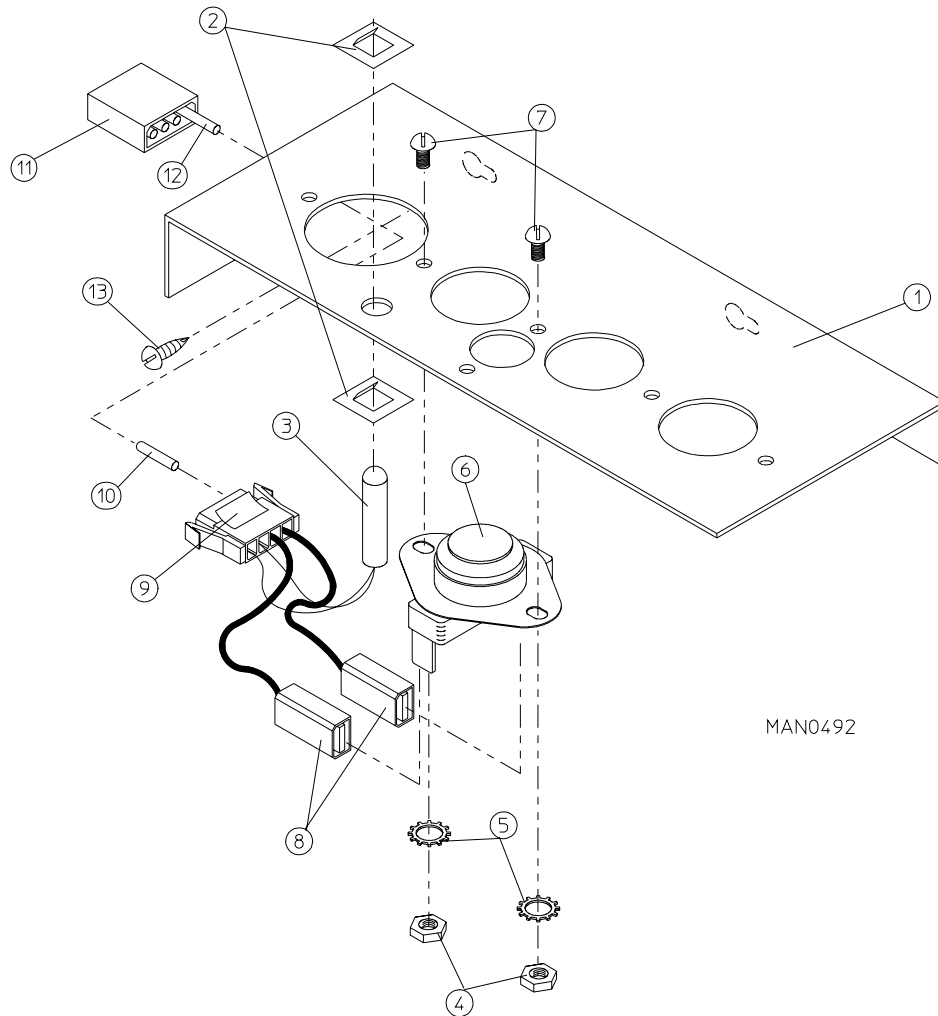

<u>Illus. No.</u>	<u>Part No.</u>	<u>Qty.</u>	<u>Description</u>
1	820022	1	Microprocessor Controller (computer) Temperature Sensor Bracket Assembly Complete (includes illus. nos. 1 through 10)
	331295	1	Temperature Sensor Bracket ONLY
2	154007	2	1/4" Tinnerman Push On Fastener
3	880251	1	1/4" Temperature Sensor Probe Assembly (includes illus. nos. 2, 3, and 8 through 10)
4	152000	2	#6-32 Hex Nut
5	153010	2	#6 Star Washer
6	130302	1	225° Large Automatic Reset Thermostat ONLY
7	150000	2	#6-32 x 1/4" Round Head Machine Screw
8	121028	2	Insulated Terminal
9	122605	1	4-Pin Socket Connector ONLY
10	122701	4	Socket Terminal ONLY
11	122604	1	4-Pin Connector ONLY
12	122700	4	Pin Terminal ONLY
	122801	1	Pin/Socket Extraction Tool
13	150301	2	#8-18 x 7/16" Phillips Pan Head TEK Screw

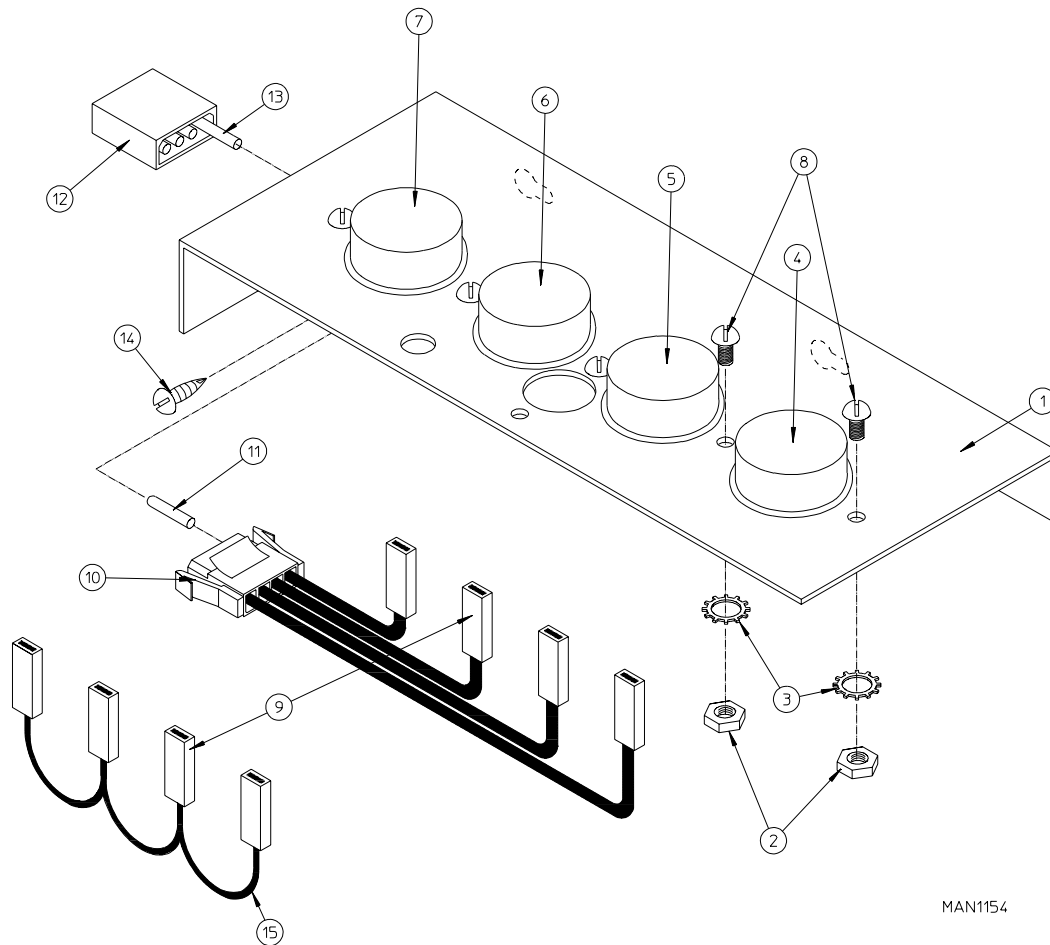

<u>Illus. No.</u>	<u>Part No.</u>	<u>Qty.</u>	<u>Description</u>
1	801404	1	Dual Timer Sensor Bracket Assembly Complete (includes illus. nos. 1 through 11 and 15)
	331295	1	Sensor Bracket ONLY
2	152000	5	#6-32 Hex Nut
3	153010	5	#6 Star Washer
4	130302	1	225° Large Thermostat ONLY
5	130107	1	160° Large Thermostat ONLY
6	130109	1	140° Large Thermostat ONLY
7	130101	1	180° Large Thermostat ONLY
8	150001	5	#6-32 x 1/2" Phillips Round Head Machine Screw
9	121028	8	Insulated Terminal
10	122605	1	4-Pin Socket (female) Connector ONLY
	840062	1	Sensor Bracket Harness Assembly (includes illus. nos. 9 through 11)
11	122701	4	Socket Terminal ONLY
12	122604	1	4-Pin Connector ONLY
13	122700	4	Pin Terminal ONLY
	122801	1	Pin/Extraction Tool
14	150301	2	#8-18 x 7/16" Phillips Pan Head TEK Screw
15	840065	1	Sensor Jumper Harness ONLY

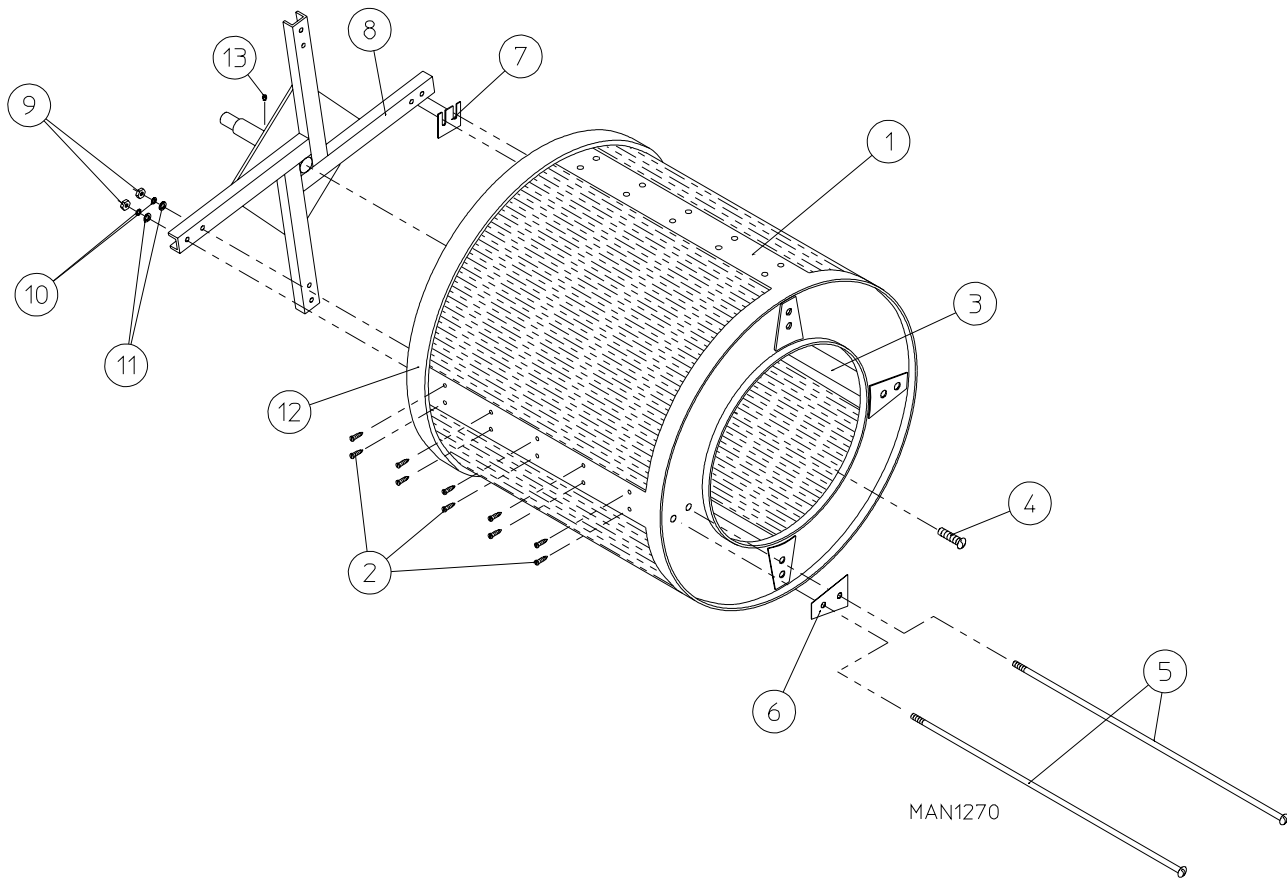

<u>Illus. No.</u>	<u>Part No.</u>	<u>Qty.</u>	<u>Description</u>
1	820110*	1	Basket (tumbler) ONLY without Felt Collar
	820111*	1	Stainless Steel Basket (tumbler) ONLY without Felt Collar
	820052	1	Basket (tumbler) and Support Assembly Complete with Rotational Sensor Option (includes illus. nos. 1 through 12)
	820029	1	Stainless Steel Basket (tumbler) and Support Assembly Complete with Rotational Sensor Option (includes illus. nos. 1 through 12)
2	150413	40	#10-16 x 1/2" TORX Crimptite Screw
3	331105	4	Basket (tumbler) Rib ONLY
	331106	4	Stainless Steel Basket (tumbler) Rib ONLY
4	150500	1	5/16-18 x 3/4" Socket Button Head Screw
5	100910	8	1/2-13 x 44" Tie Rod
6	301700	4	Basket (tumbler) Reinforcing Plate ONLY
7	301701	**	Basket (tumbler) Shim ONLY
8	820116	1	Basket (tumbler) Support ONLY with Rotational Sensor Option
9	152011	8	1/2-13 Hex Nut
10	153026	8	1/2" Lock Washer
11	153011	8	9/16" Flat Washer
12	116006	1	Felt Collar ONLY
	401010	1	#847 Adhesive for Felt Collar (5 oz. tube)
13	821002	1	Rotational Magnet Holder Assembly

* Felt collar *is not included* and **must be** ordered separately.

** As required.

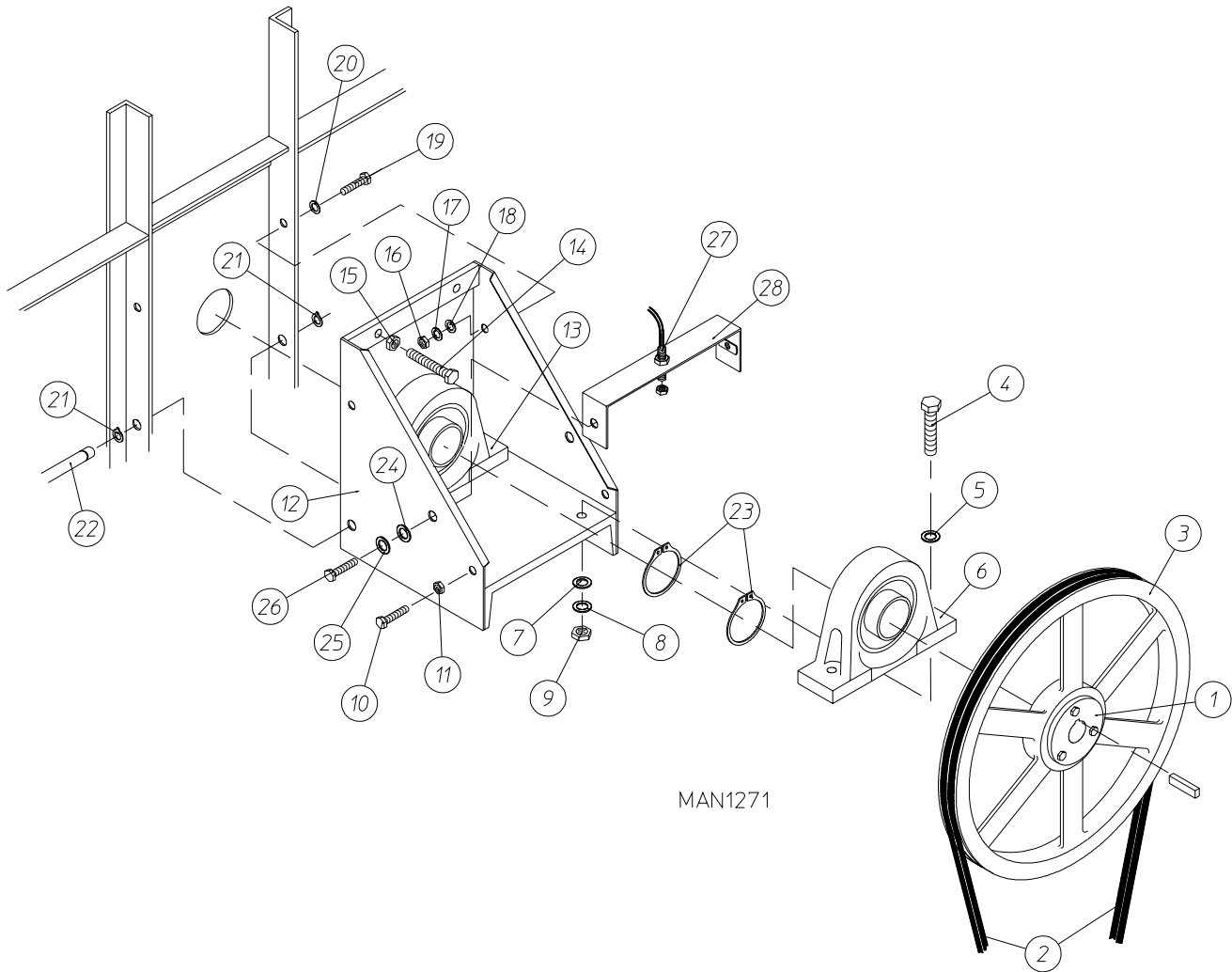

<u>Illus. No.</u>	<u>Part No.</u>	<u>Qty.</u>	<u>Description</u>
1	101137	1	2-1/4" SFX Bushing
2*	100135	2	AP-74 V-Belt
3	101136	1	20" Basket (tumbler) Pulley
4	150602	4	5/8-11 x 3" Hex Head Machine Bolt
5	153016	4	5/8" Flat Washer
6	883767	1	2-1/4" (Griplock) Pillow Block Bearing ONLY
7	153016	4	5/8" Flat Washer
8	153015	4	5/8" Lock Washer
9	152010	4	5/8-11 Hex Nut
10	150600	2	3/8-16 x 1-1/2" Hex Head Machine Bolt
11	152005	2	3/8-16 Hex Nut
12	801102	1	Basket (tumbler) Bearing Mount Assembly (includes illus. nos. 4 through 13)
13	883767	1	2-1/4" (Griplock) Pillow Block Bearing ONLY
14	150603	2	1/2-13 x 3" Square Head Machine Bolt
15	152011	2	1/2-13 Hex Nut
16	152005	2	3/8-16 Hex Nut
17	153005	2	3/8" Lock Washer
18	153004	4	3/8" Flat Washer
19	150600	2	3/8-16 x 1-1/2" Hex Head Machine Bolt
20	153004	2	3/8" Flat Washer
21	100801	2	5/8" Retaining Ring
22	883033	1	5/8" Hinge Pin Assembly
23	100811	2	2-1/4" Retaining Ring
24	153018	2	1/4" Flat Washer
25	153007	2	1/4" Lock Washer
26	150512	2	1/4-20 x 1/2" Hex Head Machine Bolt
27	824807	1	Rotational Sensor Assembly
28	880841	1	Rotational Sensor Mounting Bracket

* Replace in matched sets (both belts).

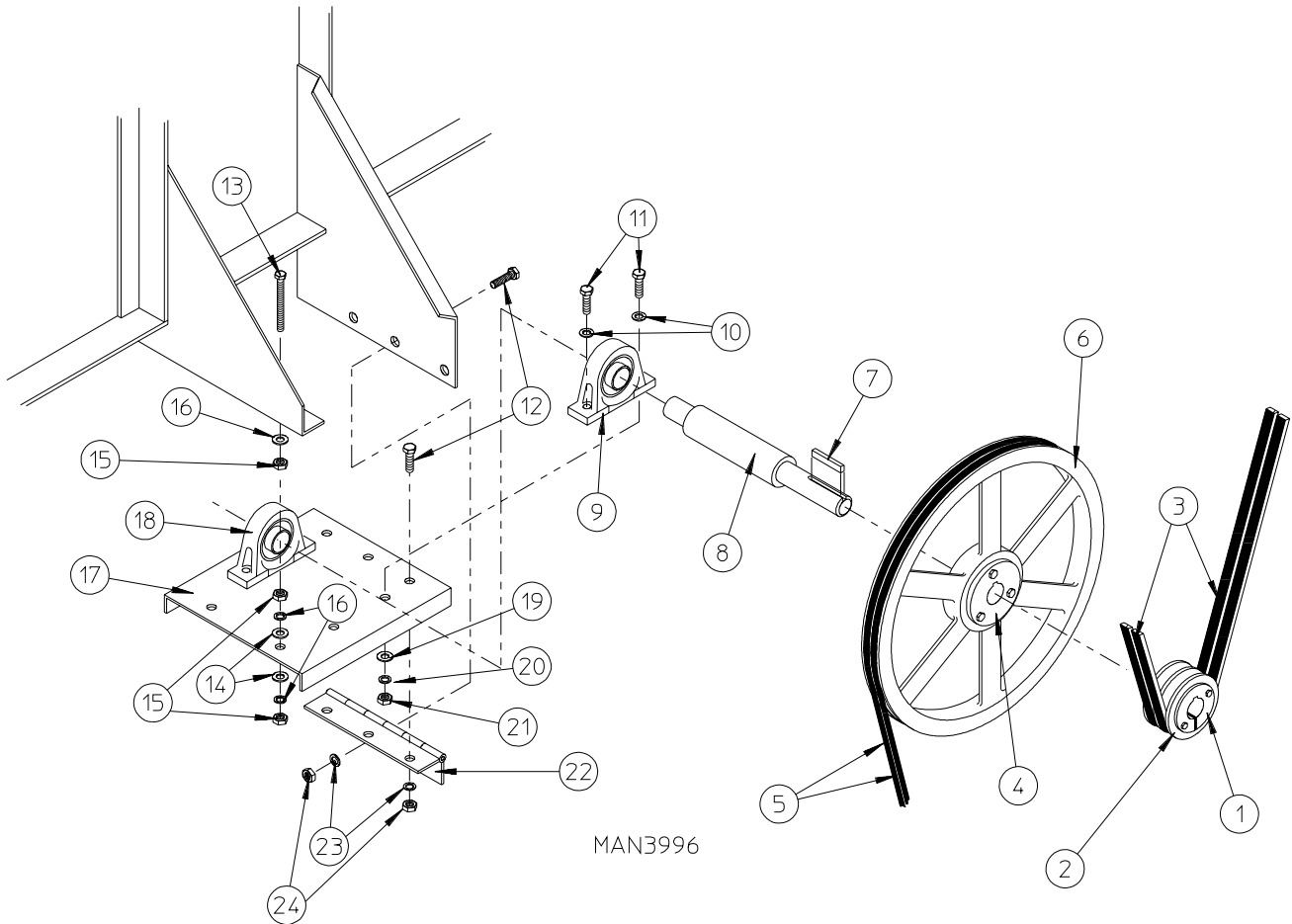

<u>Illus. No.</u>	<u>Part No.</u>	<u>Qty.</u>	<u>Description</u>
1	101110	1	1" Bushing
2	101113	1	2A3.0 Pulley
3*	100135	1	AP-74 V-Belt
4	101107	1	1" SK Bushing
5*	100170	1	3V-710 V-Belt
6	101112	1	19" Idler Pulley
7	100715	1	1/4" x 1/4" x 4-5/8" Key
8	301852	1	1" Idler Shaft ONLY
9	880205	1	1" Pillow Block Bearing ONLY
10	153004	4	3/8" Flat Washer
11	150600	4	3/8-16 x 1-1/2" Hex Head Machine Bolt
12	150512	6	1/4-20 x 1/2" Hex Head Machine Bolt
13	150509	2	5/16-18 x 3" Hex Head Machine Bolt
14	153001	4	5/16" Flat Washer
15	152004	6	5/16" Hex Nut
16	153002	8	5/16" Lock Washer
17	801001	1	Idler Bearing Mount Assembly Complete (includes illus. nos. 8 through 12 and 17 through 24)
	311401	1	Idler Bearing Mount ONLY
18	880205	1	1" Pillow Block Bearing ONLY
19	153004	4	3/8" Flat Washer
20	153005	4	3/8" Lock Washer
21	152005	4	3/8-16 Hex Nut
22	103005	1	Idler Adjustment Hinge ONLY
23	153007	6	1/4" Lock Washer
24	152002	6	1/4-20 Hex Nut

* Replace in matched sets (both belts).

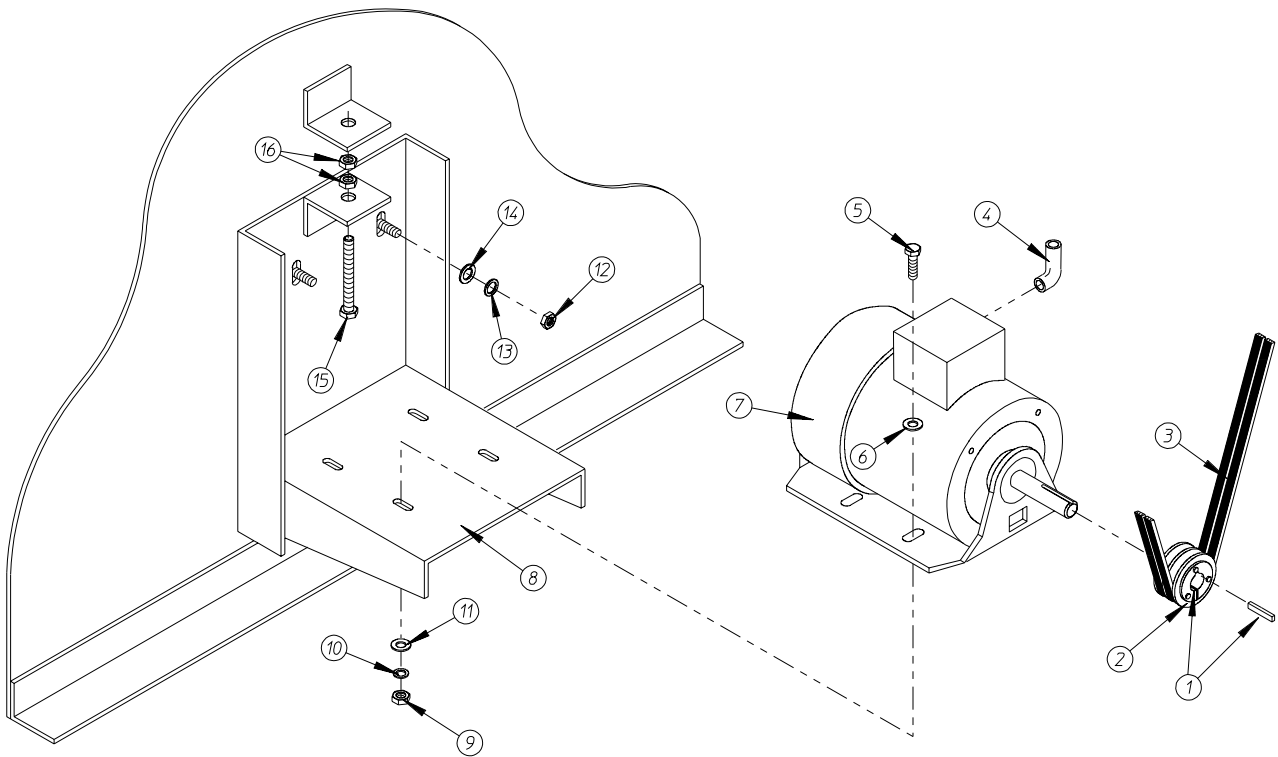

MAN0329

<u>Illus. No.</u>	<u>Part No.</u>	<u>Qty.</u>	<u>Description</u>
1	101121	1	5/8" SK Bushing
2	101114	1	2.65" Pulley (for 60 Hz models Only)
	101120	1	3.15" Pulley (for 50 Hz models Only)
3*	100170	1	3V-710 V-Belt
4	120200	1	3/8" x 90° Connector
5	150501	4	5/16-18 x 3/4" Hex Head Machine Bolt
6	153001	4	5/16" Flat Washer
7	100029	1	3/4 hp 208/230/460v 3ø 50/60 Hz and 380v 3ø 50 Hz Totally Enclosed, Fan-Cooled (T.E.F.C.) Motor (56Z frame)
	100084	1	3/4 hp 380v 3ø 60 Hz Totally Enclosed, Fan-Cooled (T.E.F.C.) Motor (56Z frame)
8	800952	1	Basket (tumbler) Motor Mount ONLY (56Z frame)
	800953**	1	3/4 hp 208/230/460v 3ø 60 Hz Basket (tumbler) Motor Mount Assembly Complete (includes illus. nos. 1, 2, 4 through 11, 15, and 16)
	800955**	1	3/4 hp 208/230/380/460v 3ø 50 Hz Motor Mount Assembly Complete (includes illus. nos. 1, 2, 4 through 11, 15, and 16)
	800956**	1	3/4 hp 380v 3ø 60 Hz Basket (tumbler) Motor Mount Assembly Complete (includes illus. nos. 1, 2, 4 through 11, 15, and 16)
9	152004	4	5/16-18 Hex Nut
10	153002	4	5/16" Lock Washer
11	153001	4	5/16" Flat Washer
12	152004	4	5/16-18 Hex Nut
13	153002	4	5/16" Lock Washer
14	153001	4	5/16" Flat Washer
15	150619	1	3/8-16 x 3" Hex Head Machine Bolt
16	152005	2	3/8-16 Hex Nut

* Replace in matched sets (both belts).

** Specify voltage when ordering.

IMPORTANT: For voltages higher than 460 VAC, contact the ADC factory for correct part number of motor mount assembly.

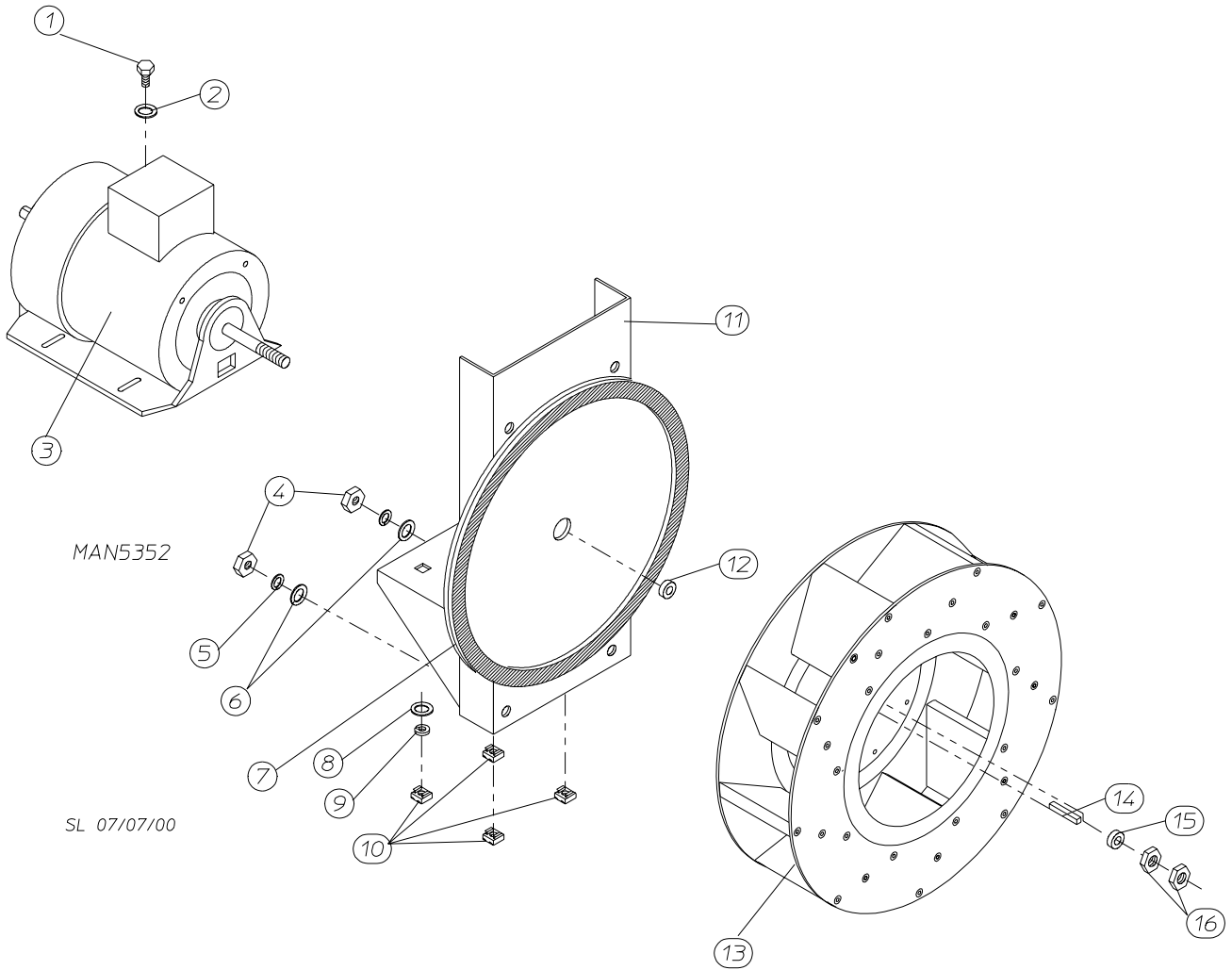

<u>Illus. No.</u>	<u>Part No.</u>	<u>Qty.</u>	<u>Description</u>
1	150501	4	5/16-18 x 1" Hex Head Bolt
2	153001	4	5/16" Flat Washer
3	181043	1	3 hp Motor 208/230/460/416v 50 Hz
	100022	1	3 hp Motor 380v 3ø 60 Hz
	100088	1	3 hp Motor 575v 3ø 60 Hz
4	152004	4	5/16-18 Hex Nut
5	153002	4	5/16" Lock Washer
6	153001	4	5/16" Flat Washer
7	117604	4'	Noise Suppressor Tape (sold by the foot)
8	153001	4	5/16" Flat Washer
9	153002	4	5/16" Lock Washer
10	152004	4	5/16-18 Hex Nut
11	803561	1	Blower Motor Mount
12	153055	1	5/8" Motor Washer
13	802027	1	16" Riveted High Flow Impellor 7/8" Bore (60 Hz dryers)
	802024	1	16" Riveted Impellor 7/8" Bore (50 Hz dryers)
14	100705	1	3/16" x 3/16" x 1-3/8" Key
15	153055	1	5/8" Motor Washer
16	152006	2	1/2-20 Left Hand Jam Nut

For Gas Models ONLY

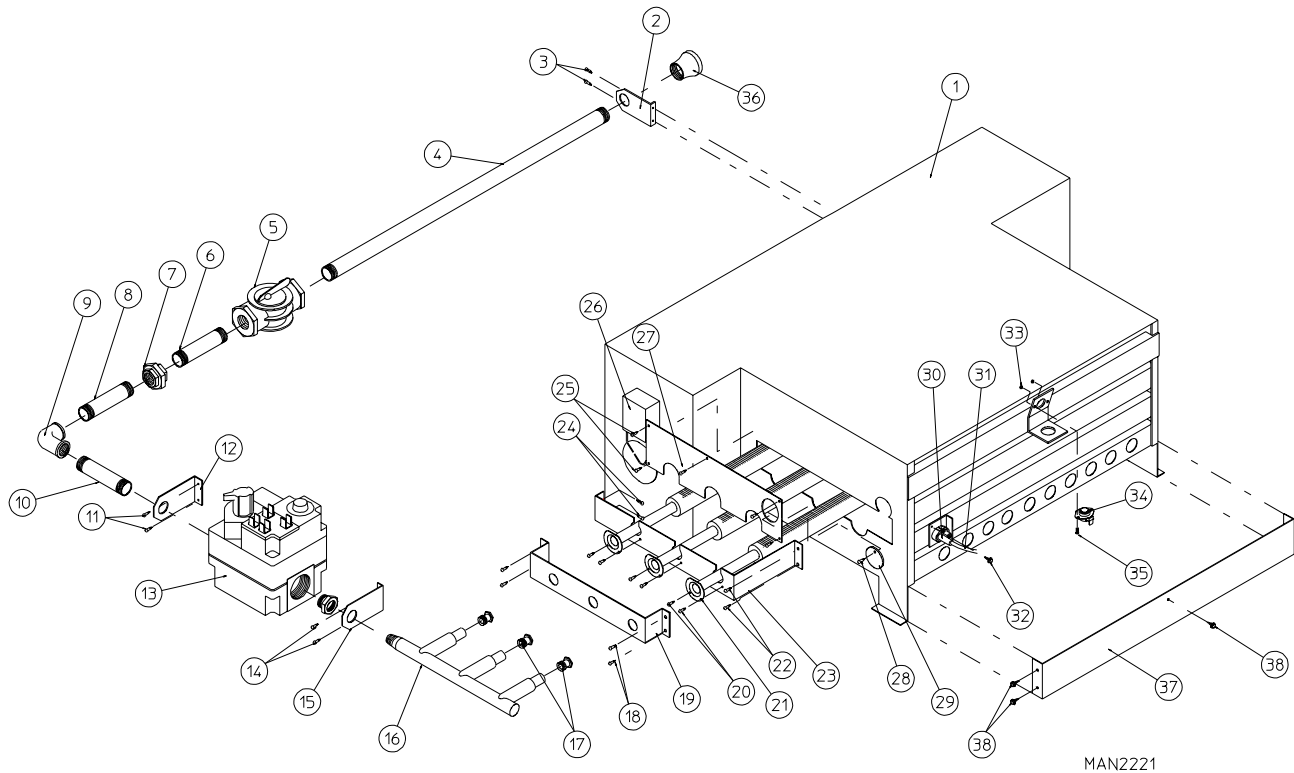

MAN2221

<u>Illus. No.</u>	<u>Part No.</u>	<u>Qty.</u>	<u>Description</u>
1	880874*	1	Direct Spark Ignition (DSI) Natural Gas Burner Assembly Complete Less Orifice (includes illus. nos. 1 through 16 and 18 through 36)
	880875*	1	Direct Spark Ignition (DSI) Liquid Propane (L.P.) Gas Burner Assembly Complete Less Orifice (includes illus. nos. 1 through 16 and 18 through 38)
	820201	1	Burner Box ONLY
2	331291	1	Pipe Bracket
3	150309	2	#10-16 x 1/2" Hex Head TEK Crimptite Screw
4	142813	1	3/4" x 32-1/2" Pipe
5	141300	1	3/4" Union Shutoff
6	142701	1	3/4" Closed Nipple
7	142601	1	3/4" Union
8	142710	1	3/4" x 4" Nipple
9	142504	1	3/4" x 90° Elbow
10	142734	1	3/4" x 5-1/2" Nipple
11	150413	2	#10-16 x 1/2" TORX Crimptite Screw
12	331291	1	Gas Valve Pipe Bracket
13	140026	1	3/4" Direct Spark Ignition (DSI) 24 VAC Redundant (natural gas) Gas Valve (3/4" to 1/2" reducing bushing included with gas valve)
	140411	-	24 VAC Gas Valve Liquid Propane (L.P.) Conversion Kit
14	150309	2	#10-16 x 1/2" Hex Head TEK Crimptite Screw
15	331291	1	Gas Valve Pipe Bracket
16	141208	1	3-Port Manifold

For Gas Models ONLY

<u>Illus. No.</u>	<u>Part No.</u>	<u>Qty.</u>	<u>Description</u>
17**	140832	3	#4 Burner Orifice (natural gas) ONLY
	140819	3	#30 Burner Orifice (liquid propane [L.P.] gas) ONLY
18	150309	4	#10-16 x 1/2" Hex Head TEK Crimptite Screw
19	331288	1	Manifold Support ONLY
20	150309	6	#10-16 x 1/2" Hex Head TEK Crimptite Screw
21	141110	3	Burner Tube ONLY
22	150309	2	#10-16 x 1/2" Hex Head TEK Crimptite Screw
23	331287	1	Burner Tube Support ONLY
24	150309	2	#10-16 x 1/2" Hex Head TEK Crimptite Screw
25	150309	6	#10-16 x 1/2" Hex Head TEK Crimptite Screw
26	-----	1	Sail Switch (refer to Sail Switch Assembly on page 34)
27	331289	1	Burner Box Cover Plate ONLY
28	150413	1	#10-16 x 1/2" Phillips Round Head Screw
29	331290	1	Ignitor/Flame-Probe Sight Hole Disc ONLY
30	880325	1	Ignitor High Voltage (HV) Wire/Connector ONLY (includes high voltage [HV] wire and connector)
	305410	1	Direct Spark Ignition (DSI) Ignitor Gap Feeler Gauge...Not Illustrated
31	880330	1	Direct Spark Ignition (DSI) Ignitor High Voltage (HV) Wire/Connector ONLY
32	150413	2	#10-16 x 1/2" Phillips Round Head Screw
33	151000	2	#6-32 Pal Nut
34	130201	1	330° Hi-Limit Small Manual Reset Thermostat ONLY
35	150001	2	#6-32 x 1/2" Round Head Machine Screw
36	142924	1	1" to 3/4" Reducing Coupling
	142937	1	1" BSPT x 3/4" N.P.T. Coupling (for CE models Only)
37***	332256	1	Liquid Propane (L.P.) Burner Baffle ONLY
38***	150309	5	#10-16 x 1/2" Hex Head TEK Crimptite Screw
---	880886**	1	Direct Spark Ignition (DSI) Liquid Propane (L.P.) Conversion Kit (with 3/4" White-Rodgers gas valve)

* Orifices *are not included* and **must be** ordered separately.

** Consult factory for elevations over 2,000 feet.

*** For liquid propane (L.P.) gas models ONLY.

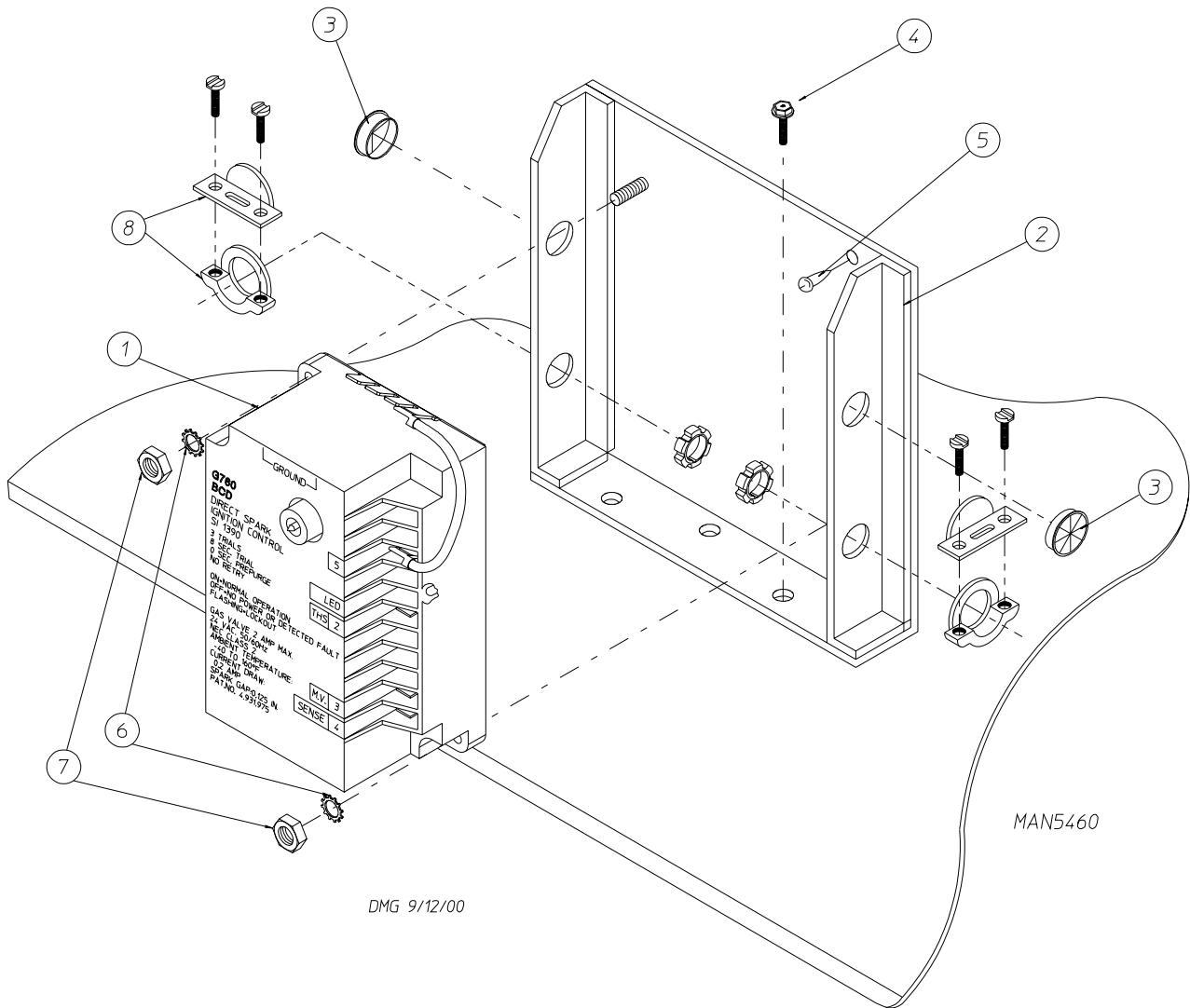

<u>Illus. No.</u>	<u>Part No.</u>	<u>Qty.</u>	<u>Description</u>
1	128935	1	Direct Spark Ignition (DSI) Module ONLY - 50/60 Hz
2	820100	1	Direct Spark Ignition (DSI) Module Mount Assembly ONLY
3	121400	2	Universal Bushing
4	150522	3	1/4-20 x 1/2" Hex Head TEK Screw
5	150301	1	#8-18 x 7/16" Phillips Pan Head TEK Screw
6	153010	4	#6 Star Washer
7	152000	4	#6-32 Hex Nut
8	120102	2	3/8" Straight x 1/2" Knock-Out Connector

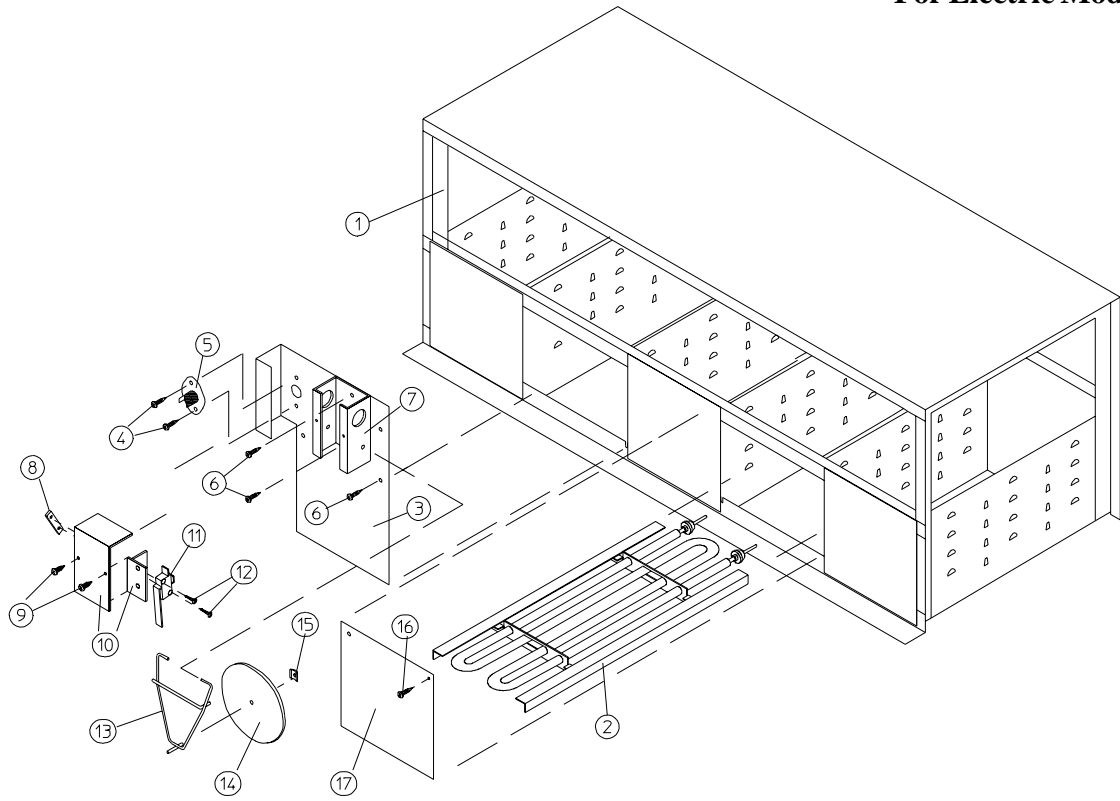

MAN1638

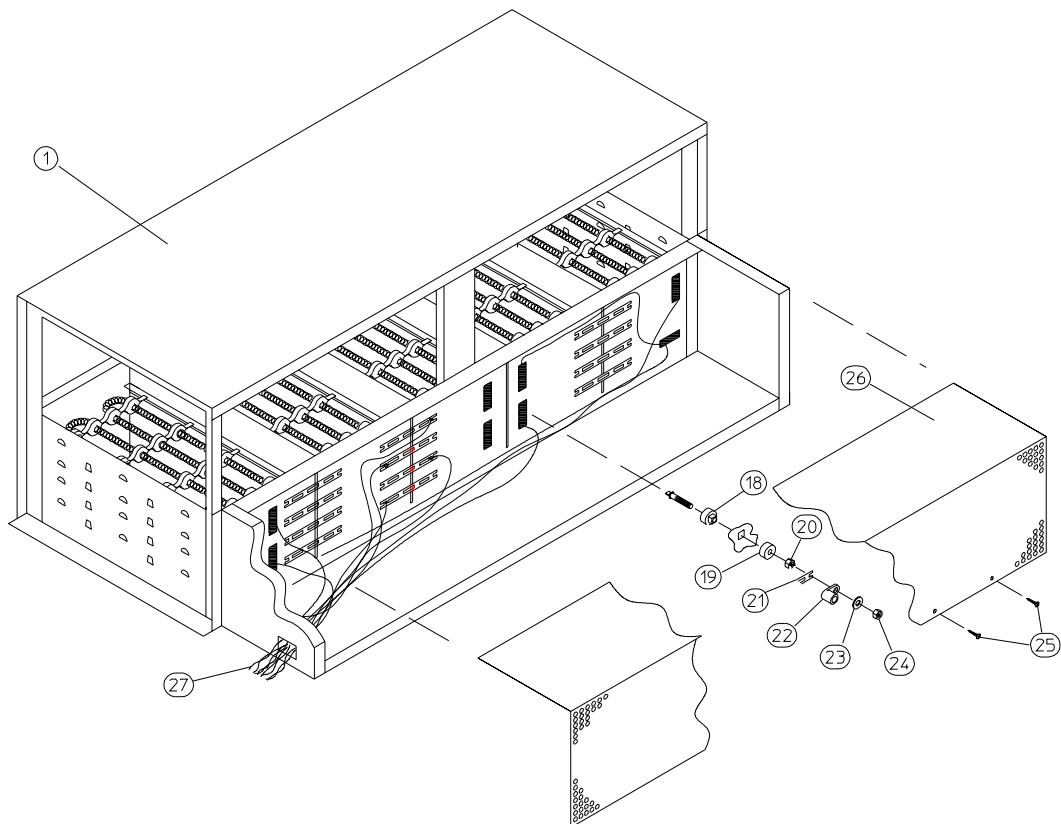

For Electric Models ONLY

<u>Illus. No.</u>	<u>Part No.</u>	<u>Qty.</u>	<u>Description</u>
1	816103	1	Electric Oven Box ONLY
	-----*	1	Electric Oven Assembly Complete
2	-----*	18	Electric Element
3	802802	1	Safety Control Bracket ONLY
4	150301	2	#8-18 x 7/16" Phillips Pan Head TEK Screw
5	130400	1	290° Hi-Limit ONLY
6	150309	4	#10-16 x 1/2" Hex Head TEK Crimptite Screw
7	802800	1	Sail Switch Box with Cover and Bracket ONLY
	802801	1	Sail Switch Box Assembly Complete (includes illus. nos. 7 through 15)
8	154004	1	Twin Speed Nut
9	150309	2	#10-16 x 1/2" Hex Head TEK Crimptite Screw
10	802799	1	Sail Switch Box with Cover and Bracket ONLY
11	122200	1	Sail Switch ONLY
12	150303	2	#4 x 3/4" Pan Head "A" Machine Screw
13	105500	1	Sail Switch Actuator Rod
14	319202	1	Sail Switch Damper (flat)
15	154002	1	1/8" Push On Fastener
16	150413	8	#10-16 x 1/2" TORX Crimptite Screw
17	803101	4	Element Cover ONLY
18	120081	36	Internal Ceramic Insulator
19	120080	36	External Ceramic Insulator
20	152008	36	#10-32 Hex Nut
21	121011*	---	Bus Bar (sold by the foot)
22	121010*	---	Terminal Lug
23	153009	36	#10 Star Washer
24	152008	36	#10-32 Hex Nut
25	150413	14	#10-16 x 1/2" TORX Crimptite Screw
26	320823	1	Electric Wire Burner Cover ONLY
	321400	1	Electric Wire Burner Cover ONLY
27	-----*	-	Oven Wire (sold by the foot)

* Refer to **Electric Oven Component Application Listings** on **page 48**.

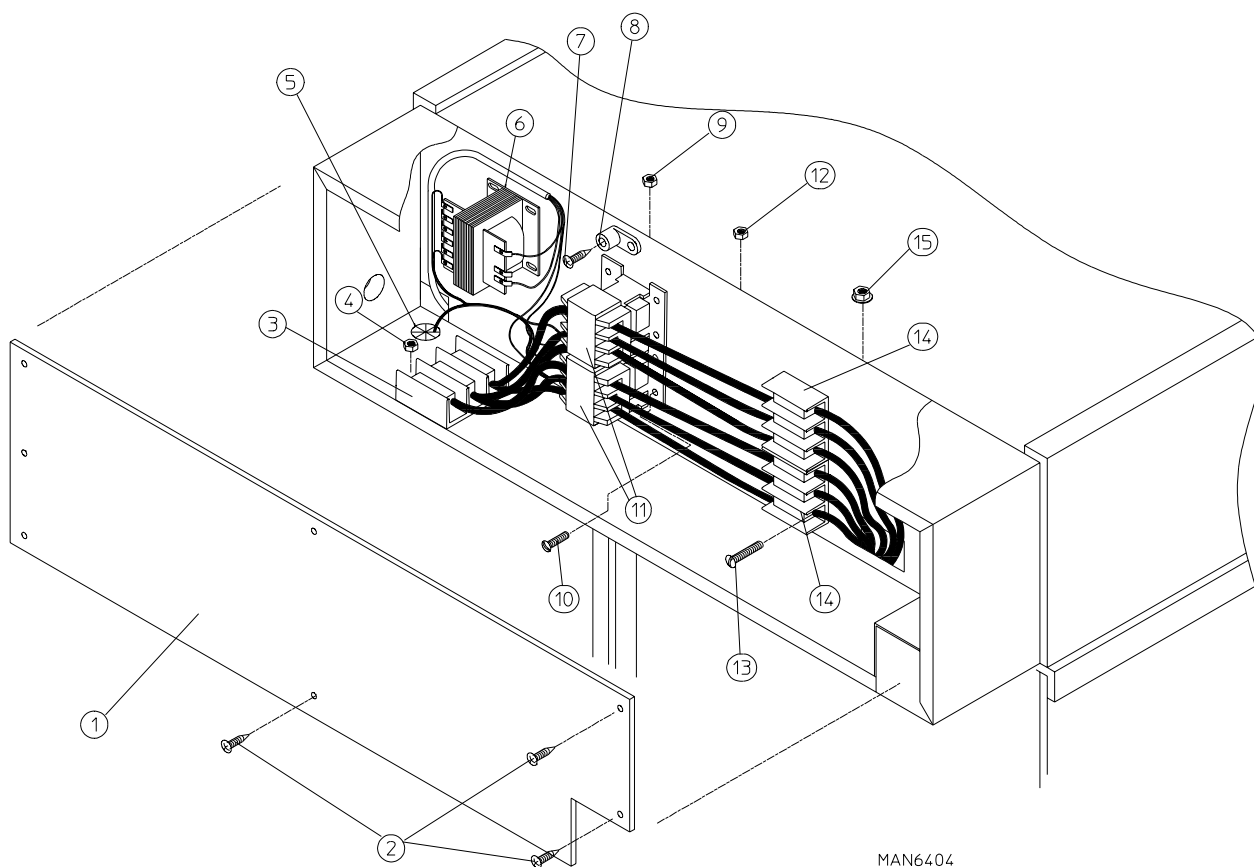

MAN6404

MGOLDSTEIN 12/17/02

<u>Illus. No.</u>	<u>Part No.</u>	<u>Qty.</u>	<u>Description</u>
1	331328	1	Electric Oven Relay Box Cover
2	150301	8	#8-18 x 7/16" Phillips Pan Head TEK Screw
3	120710	1	Power Distribution Block
4	151001	2	#8-32 Pal Nut
5	121400	2	Universal Bushing
6	132004	1	Transformer
			(for ALL microprocessor controller [computer] models and timer models)
7	150108	3	#8-32 x 1/2" Pan Head Machine Screw
8	121010	1	L-70 Terminal Lug
9	151001	1	#8-32 Pal Nut
10	150108	1	#8-32 x 1/2" Pan Head Machine Screw
11	131385	2	Single Pole Single Throw 112-amp - 24 VAC Relay
12	151001	3	#8-32 Pal Nut
13	150521	2	1/4-20 x 2" Carriage Bolt
14	120706	1	Power Distribution Block
15	152014	2	1/4-20 Free Spin Wash Nut

380-416/480 VAC 3 ϕ 50/60 Hz

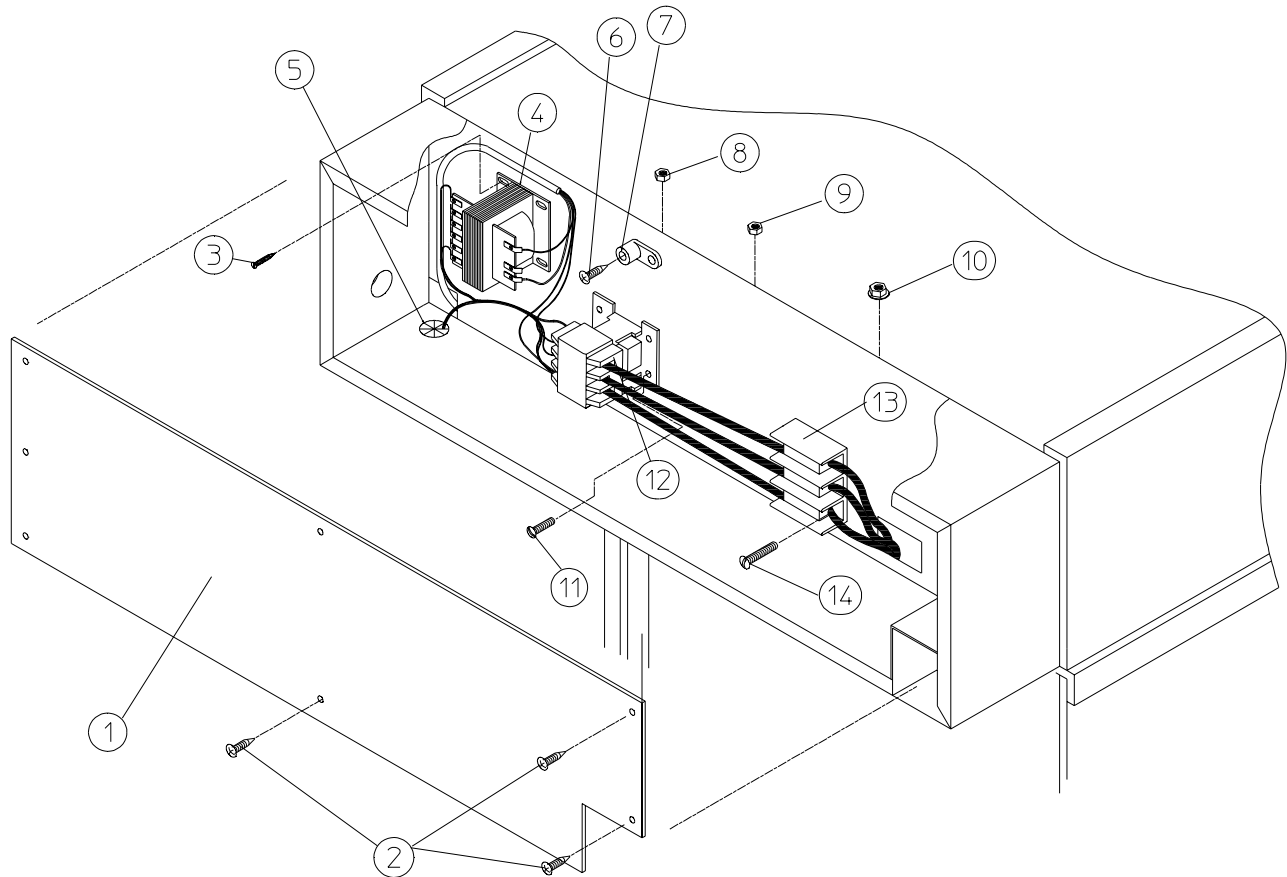

MAN6405

MGOLDSTEIN 12/17/02

<u>Illus. No.</u>	<u>Part No.</u>	<u>Qty.</u>	<u>Description</u>
1	331328	1	Electric Oven Relay Box Cover
2	150301	8	#8-18 x 7/16" Phillips Pan Head TEK Screw
3	150300	3	#10 x 1/2" Hex Washer TEK Screw
4	132004	1	Transformer (for ALL electric models - 380 VAC through 480 VAC)
5	121400	2	Universal Bushing
6	150108	3	#8-32 x 1/2" Pan Head Machine Screw
7	121010	1	L-70 Terminal Lug
8	151001	1	#8-32 Pal Nut
9	151001	3	#8-32 Pal Nut
10	152014	2	1/4-20 Free Spin Wash Nut
11	150108	1	#8-32 x 1/2" Pan Head Machine Screw
12	131385	1	Single Pole Single Throw 112-amp - 24 VAC Relay
13	120706	1	Power Distribution Block
14	150501	2	1/4-20 x 2" Carriage Bolt

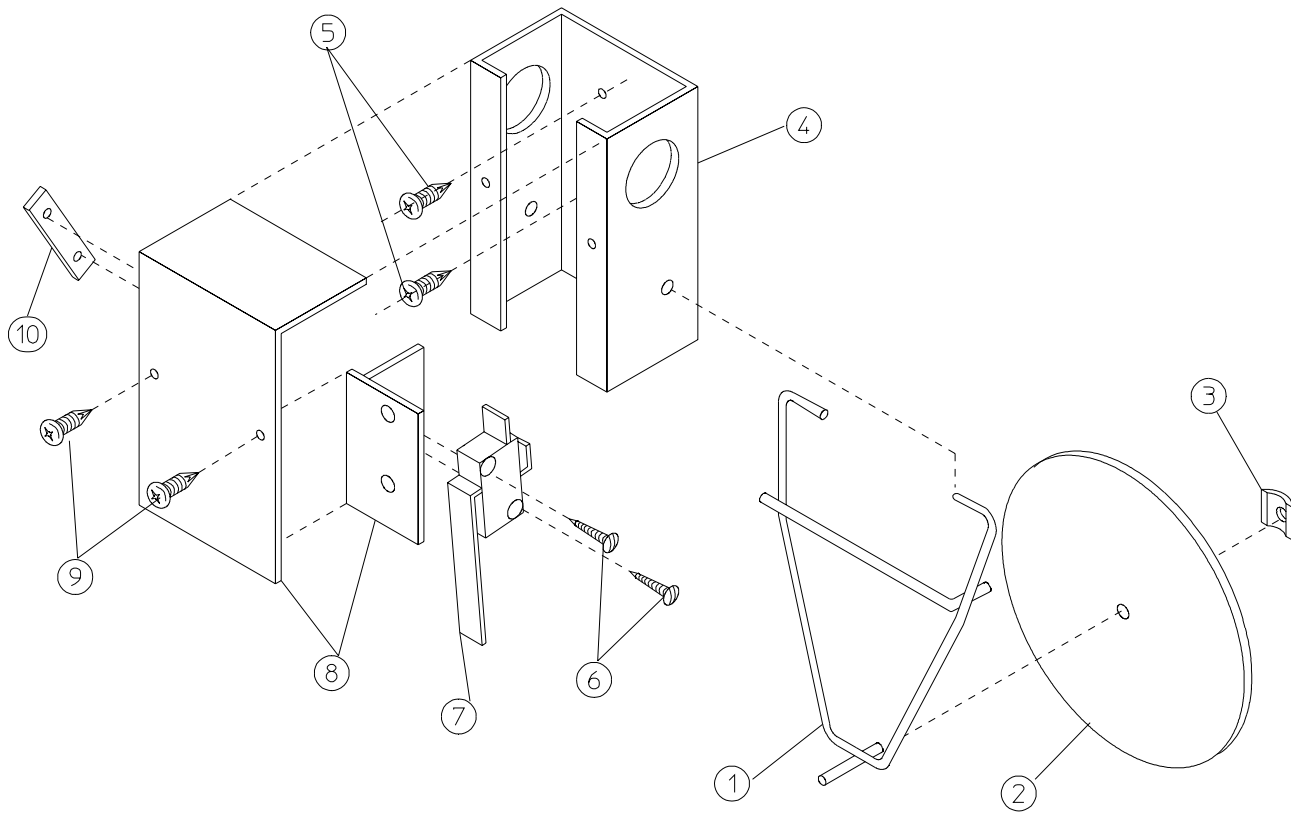

MAN0440

<u>Illus. No.</u>	<u>Part No.</u>	<u>Qty.</u>	<u>Description</u>
1	105500	1	Sail Switch Actuator Rod
2	319202	1	Sail Switch Damper (flat)
3	154002	1	1/8" Push On Fastener
4	802800	1	Sail Switch Box Cover and Bracket ONLY
	802801	1	Sail Switch Box Assembly Complete (includes illus. nos. 1 through 4 and 6 through 10)
5	150309	2	#10 x 1/2" Hex Head TEK Crimptite Screw
6	150303	2	#4 x 3/4" Pan Head "A" Machine Screw
7	122200	1	Sail Switch ONLY
8	802799	1	Sail Switch Box Cover and Bracket ONLY
9	150413	2	#10-16 x 1/2" TORX Crimptite Screw
10	154004	1	Twin Speed Nut

For Steam Models ONLY

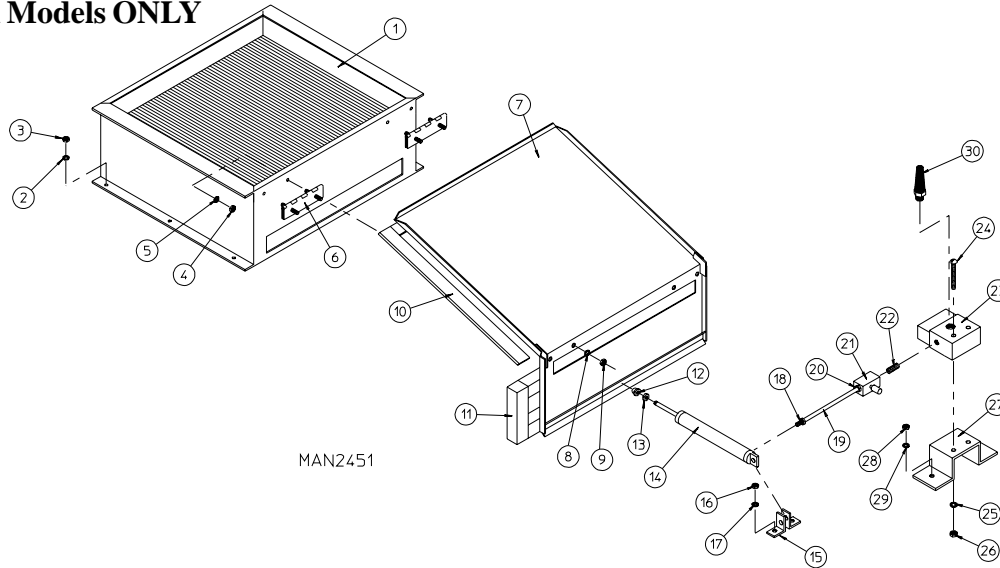

MAN2451

<u>Illus. No.</u>	<u>Part No.</u>	<u>Qty.</u>	<u>Description</u>
1	165012	1	Steam Coil Assembly
	165019	1	Steel Steam Coil Assembly (optional)
2	153002	6	5/16" Lock Washer
3	152004	6	5/16-18 Hex Nut
4	152002	4	1/4-20 Hex Nut
5	153007	4	1/4" Lock Washer
6	820321	2	Steam Damper Hinge Assembly
7	820320	1	Steam Damper Assembly (includes illus. nos. 7, 10, and 11)
8	153007	4	1/4" Lock Washer
9	152002	4	1/4-20 Hex Nut
10	115995	84	Steam Damper Gasket (sold by the inch)
11	102350	1	Steam Damper Foam (68-1/2" length)
12	151007	1	7/16-20 Stainless Steel Acorn Nut
13	152007	1	7/16-20 Hex Nut
14	100499	1	1-1/2" Bore x 3" Stroke Piston
15	100500	1	Piston Support Bracket
16	152002	4	1/4-20 Hex Nut
17	153007	4	1/4" Lock Washer
18	100472	1	1/4" x 1/8" Connector
19	143110	1	1/4" Tubing (sold by the foot)
20	100472	1	1/4" x 1/8" Connector
21	100496	1	1/8" Needle Valve
22	143238	1	1/8" Close Nipple
23	100498	1	3-Way Micro Valve - 24 VAC
24	150002	2	#6-32 x 1" Slotted Machine Screw
25	153010	2	#6 Star Washer
26	152000	2	#6-32 Hex Nut
27	330987	1	Micro Valve Support Bracket
28	152002	2	1/4-20 Hex Nut
29	153007	2	1/4" Lock Washer
30	100520	1	1/8" N.P.T. Silencer (muffler)

36 Microprocessor Reversing Contactor Mounting Panel Assembly (Gas and Steam)

208-240 Volt 3Ø

For Models Mfd. prior to February 3, 2002

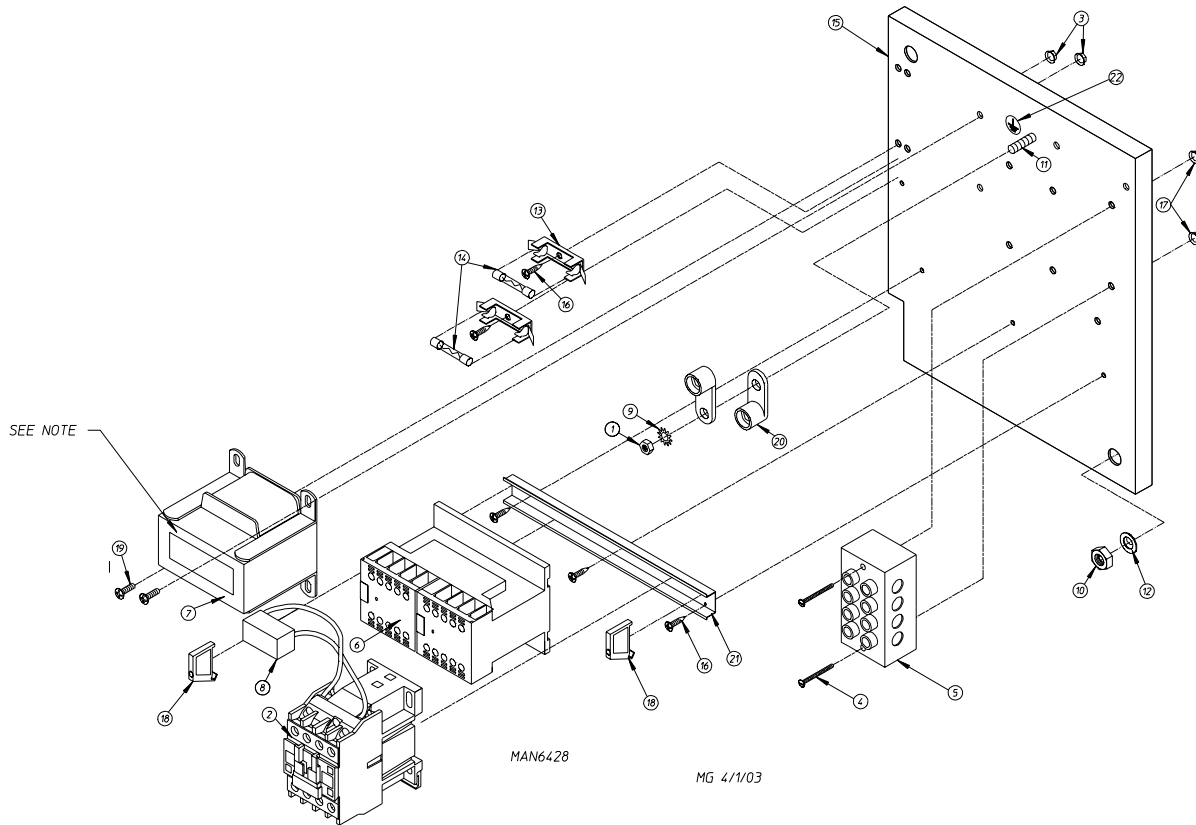

<u>Illus. No.</u>	<u>Part No.</u>	<u>Qty.</u>	<u>Description</u>
1	152002	1	1/4-20 Hex Nut
2	132445	1	3 hp Contactor
3	151001	2	#8-32 Pal Nut
4	150009	2	#6-32 x 1-1/2" Slotted Round Head Machine Screw
5	120701	1	4-Position Terminal Block
6	132497	1	Reversing Contactor
7	822745	1	208-240V Transformer Assembly
8	137015	1	Arc Suppressor with 3" Insulated Leads
9	153021	1	1/4" External/Internal Shake Proof Washer
10	152004	1	5/16-18 Hex Nut
11	153525	2	1/4-20 x 1" Self-Clinching Stud
12	153002	1	5/16" Lock Washer
13	136008	2	Fuse Holder
14	136057	2	1/2-Amp 3AG (Slo-Blo) Fuse
15	332346	1	Relay Panel
16	150301	5	#8-18 x 7/16" Phillips Head TEK Screw
17	151000	2	#6-32 Pal Nut
18	120765	2	End Stop
19	150108	2	#8-32 x 1/2" Phillips Pan Head Machine Screw
20	121010	2	L-70 14-4 Terminal Lug
21	120768	7-3/4"	35 x 15mm Din Rail
22	112075	1	Ground Label

380-416 Volt 3 ϕ

For Models Mfd. prior to February 3, 2002

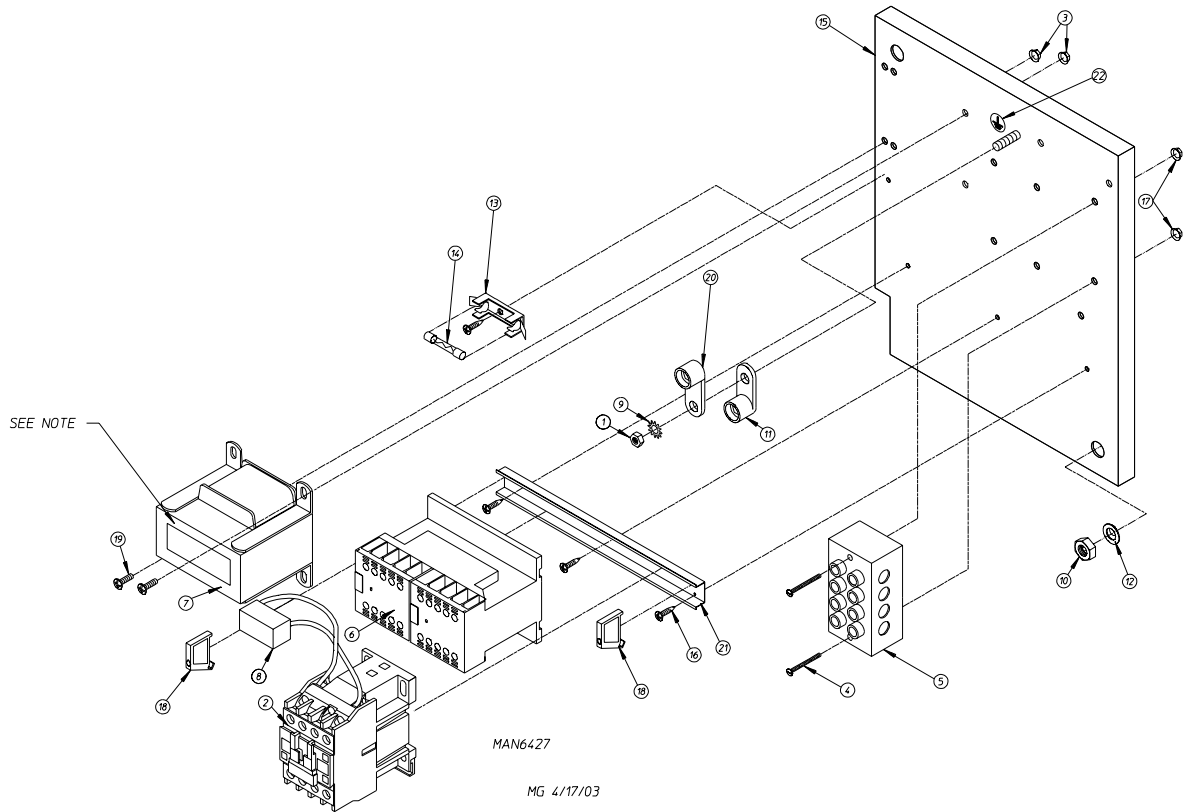

<u>Illus. No.</u>	<u>Part No.</u>	<u>Qty.</u>	<u>Description</u>
1	152002	1	1/4-20 Hex Nut
2	132445	1	3 hp Contactor
3	151001	2	#8-32 Pal Nut
4	150009	2	#6-32 x 1-1/2" Slotted Round Head Machine Screw
5	120701	1	4-Position Terminal Block
6	132497	1	Reversing Contactor
7	801850	1	380-416V Transformer Assembly
8	137015	1	Arc Suppressor with 3" Insulated Leads
9	153021	1	1/4" External/Internal Shake Proof Washer
10	152004	1	5/16-18 Hex Nut
11	121012	1	Ground Lug
12	153002	1	5/16" Lock Washer
13	136008	1	Fuse Holder
14	136057	1	1/2-amp 3AG (Slo-Blo) Fuse
15	332346	1	Relay Panel
16	150301	4	#8-18 x 7/16" Phillips Head TEK Screw
17	151000	2	#6-32 Pal Nut
18	120765	2	End Stop
19	150108	2	#8-32 x 1/2" Phillips Pan Head Machine Screw
20	121010	1	L-70 14-4 Terminal Lug
21	120768	7-3/4"	35 x 15mm Din Rail
22	112075	1	Ground Label

38 Microprocessor Reversing Contactor Mounting Panel Assembly (Electric)

208-240 Volt 3ø
For Models Mfd. prior to February 2003

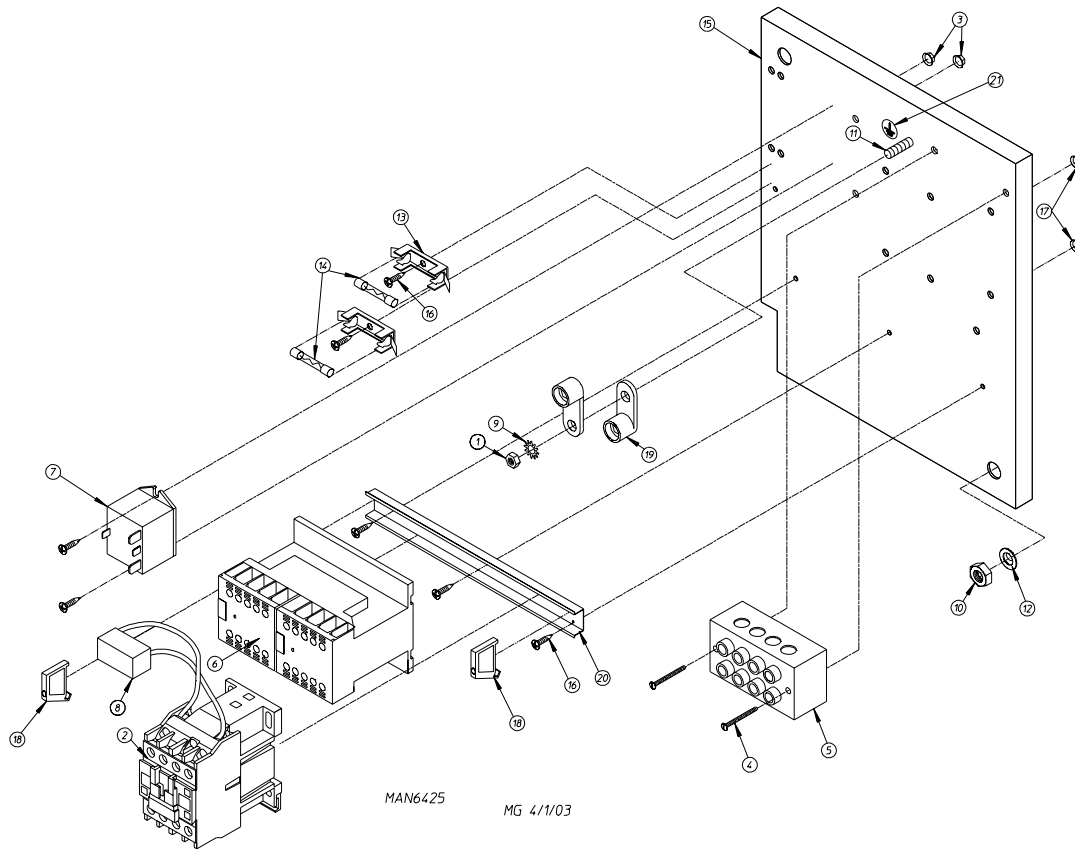

<u>Illus. No.</u>	<u>Part No.</u>	<u>Qty.</u>	<u>Description</u>
1	152002	1	1/4-20 Hex Nut
2	132445	1	3 hp Contactor
3	151001	2	#8-32 Pal Nut
4	150009	2	#6-32 x 1-1/2" Slotted Round Head Machine Screw
5	120701	1	4-Position Terminal Block
6	132497	1	Reversing Contactor
7	131932	1	Relay
8	137015	1	Arc Suppressor with 3" Insulated Leads
9	153021	1	1/4" External/Internal Shake Proof Washer
10	152004	1	5/16-18 Hex Nut
11	153525	2	1/4-20 x 1" Self-Clinching Stud
12	153002	1	5/16" Lock Washer
13	136008	2	Fuse Holder
14	136112	2	1.5-amp 3AG (Slo-Blo) Fuse
15	332346	1	Relay Panel
16	150301	7	#8-18 x 7/16" Phillips Head TEK Screw
17	151000	2	#6-32 Pal Nut
18	120765	2	End Stop
19	121010	2	L-70 14-4 Terminal Lug
20	120768	7-3/4"	35 x 15mm Din Rail
21	112075	1	Ground Label

Microprocessor Reversing Contactor Mounting Panel Assembly (Electric) 39

380-480 Volt 3 ϕ

For Models Mfd. prior to February 2003

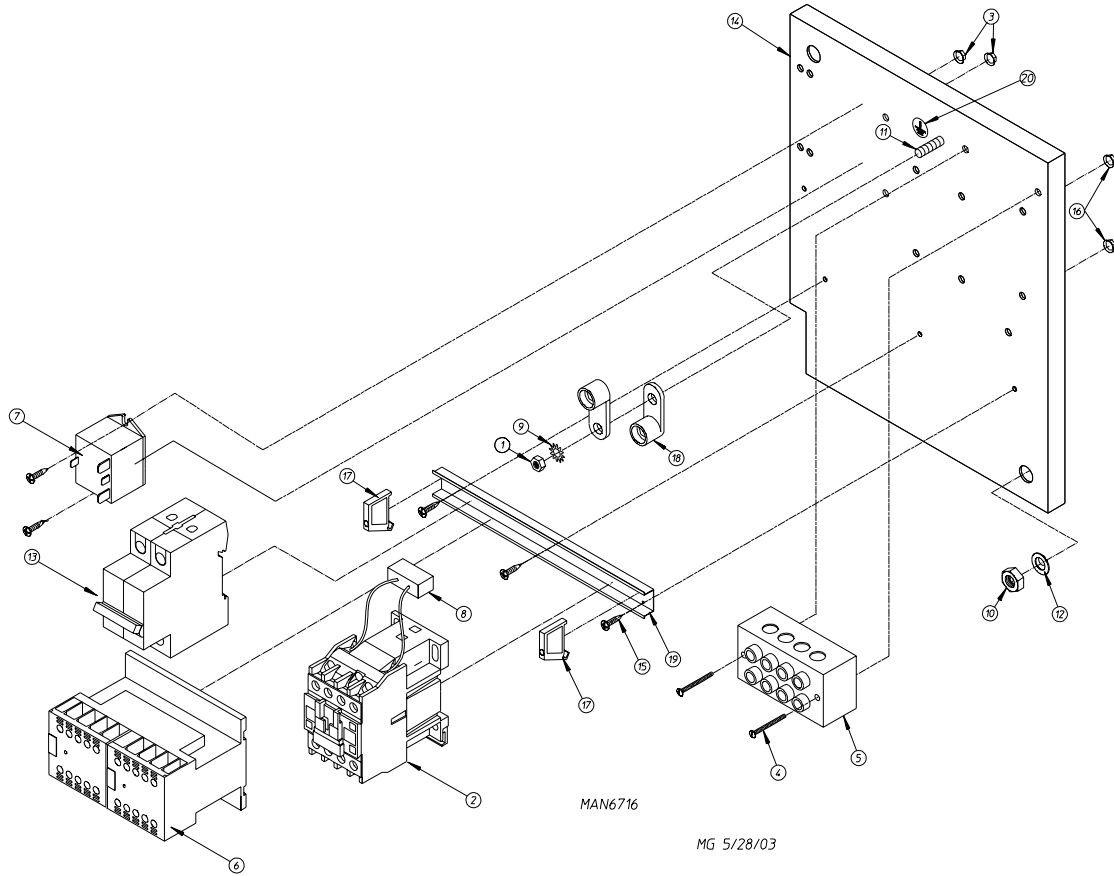

<u>Illus. No.</u>	<u>Part No.</u>	<u>Qty.</u>	<u>Description</u>
1	152002	1	1/4-20 Hex Nut
2	132445	1	3 hp Contactor
3	151001	2	#8-32 Pal Nut
4	150009	2	#6-32 x 1-1/2" Slotted Round Head Machine Screw
5	120701	1	4-Position Terminal Block
6	132497	1	Reversing Contactor
7	131932	1	Relay
8	137015	1	Arc Suppressor with 3" Insulated Leads
9	153021	1	1/4" External/Internal Shake Proof Washer
10	152004	1	5/16-18 Hex Nut
11	153525	2	1/4-20 x 1" Self-Clinching Stud
12	153002	1	5/16" Lock Washer
13	135501	1	2-Pole 1-amp Circuit Breaker
14	332346	1	Relay Panel
15	150301	7	#8-18 x 7/16" Phillips Head TEK Screw
16	151000	2	#6-32 Pal Nut
17	120765	2	End Stop
18	121010	2	L-70 14-4 Terminal Lug
19	120768	7-3/4"	35 x 15mm Din Rail
20	112075	1	Ground Label

40 Microprocessor Reversing Contactor Mounting Panel Assembly (Electric)

208-240 Volt 3 ϕ
For Models Mfd. as of February 2003

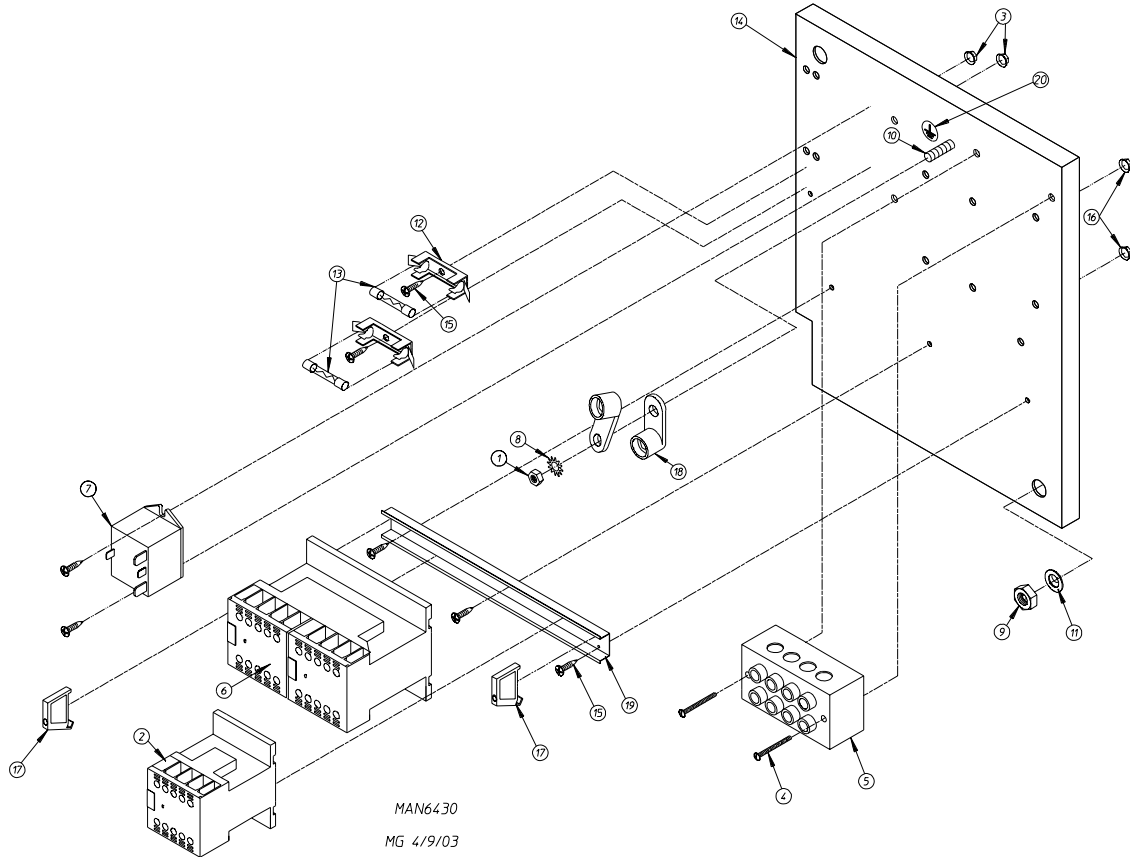

Illus. No.	Part No.	Qty.	Description
1	152002	1	1/4-20 Hex Nut
2	132514	1	3 ϕ Contactor with Arc Suppressor
3	151001	2	#8-32 Pal Nut
4	150009	2	#6-32 x 1-1/2" Slotted Round Head Machine Screw
5	120701	1	4-Position Terminal Block
6	132497	1	Reversing Contactor
7	131932	1	Relay
8	153021	1	1/4" External/Internal Shake Proof Washer
9	152004	1	5/16-18 Hex Nut
10	153525	2	1/4-20 x 1" Self-Clinching Stud
11	153002	1	5/16" Lock Washer
12	136008	2	Fuse Holder
13	136112	2	1.5-amp 3AG (Slo-Blo) Fuse
14	332346	1	Relay Panel
15	150301	7	#8-18 x 7/16" Phillips Head TEK Screw
16	151000	2	#6-32 Pal Nut
17	120765	2	End Stop
18	121010	2	L-70 14-4 Terminal Lug
19	120768	7-3/4"	35 x 15mm Din Rail
20	112075	1	Ground Label

Microprocessor Reversing Contactor Mounting Panel Assembly (Electric) 41

380-480 Volt 3 ϕ

For Models Mfd. as of February 2003

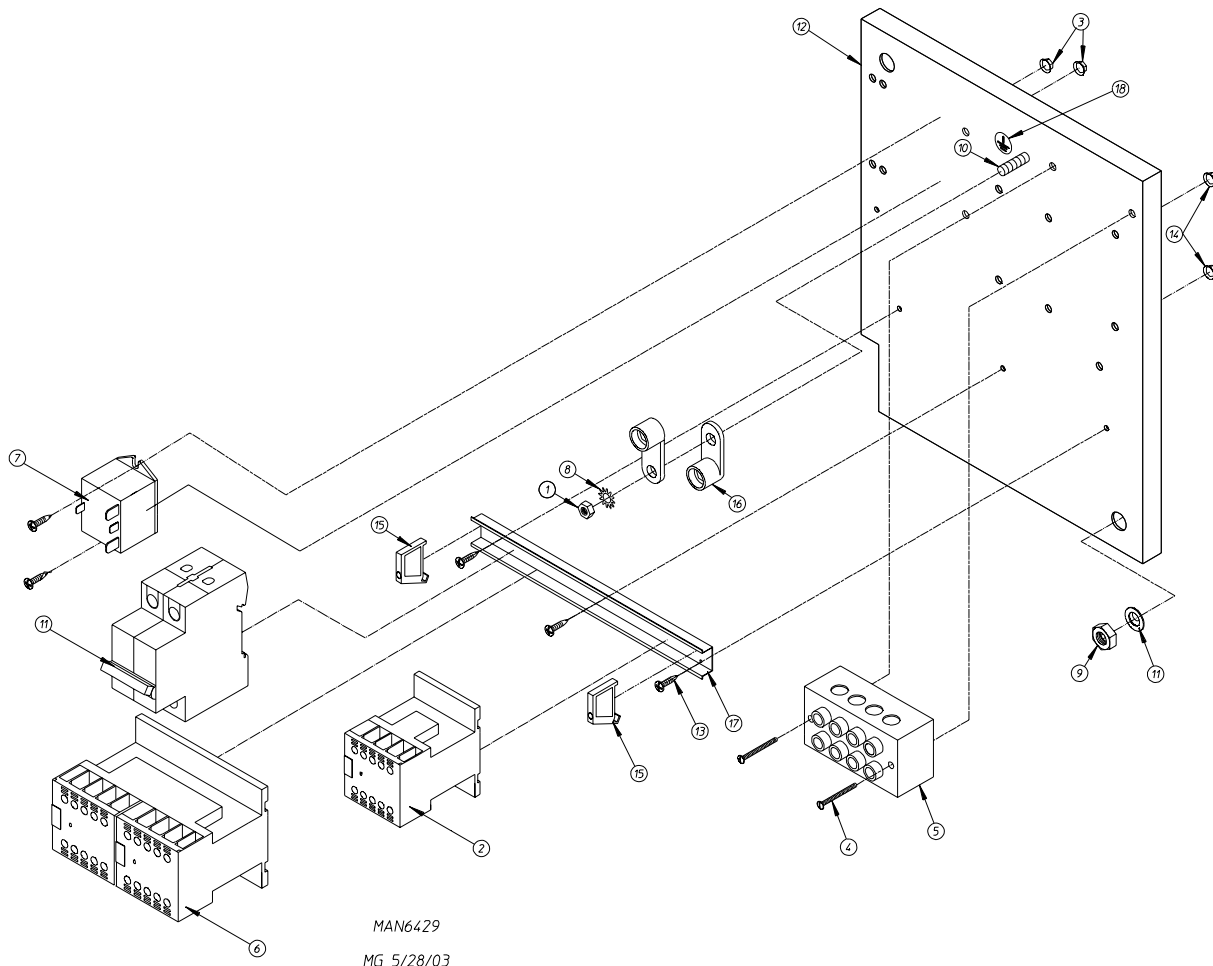

MAN6429
MG 5/28/03

<u>Illus. No.</u>	<u>Part No.</u>	<u>Qty.</u>	<u>Description</u>
1	152002	1	1/4-20 Hex Nut
2	132514	1	3 ϕ Contactor with Arc Suppressor
3	151001	2	#8-32 Pal Nut
4	150009	2	#6-32 x 1-1/2" Slotted Round Head Machine Screw
5	120701	1	4 Position Terminal Block
6	132497	1	Reversing Contactor with Arc Suppressor
7	131932	1	Relay
8	153012	1	1/4" Exterior/Interior Shake Proof Washer
9	152004	1	5/16-18 Hex Nut
10	153525	2	1/4-20 x 1" Self-Clinching Stud
11	135501	1	2-Pole 1-amp Circuit Breaker
12	332346	1	Relay Panel
13	150301	7	#8-18 x 7/16" Phillips Head TEK Screw
14	151000	2	#6-32 Pal Nut
15	120765	2	End Stop
16	121010	2	L-70 14-4 Terminal Lug
17	120768	7-3/4"	35 x 15mm Din Rail
18	112075	1	Ground Label

42 Microprocessor Reversing Contactor Mounting Panel Assembly (Gas and Steam)

208-240 Volt
For Models Mfd. as of February 3, 2003

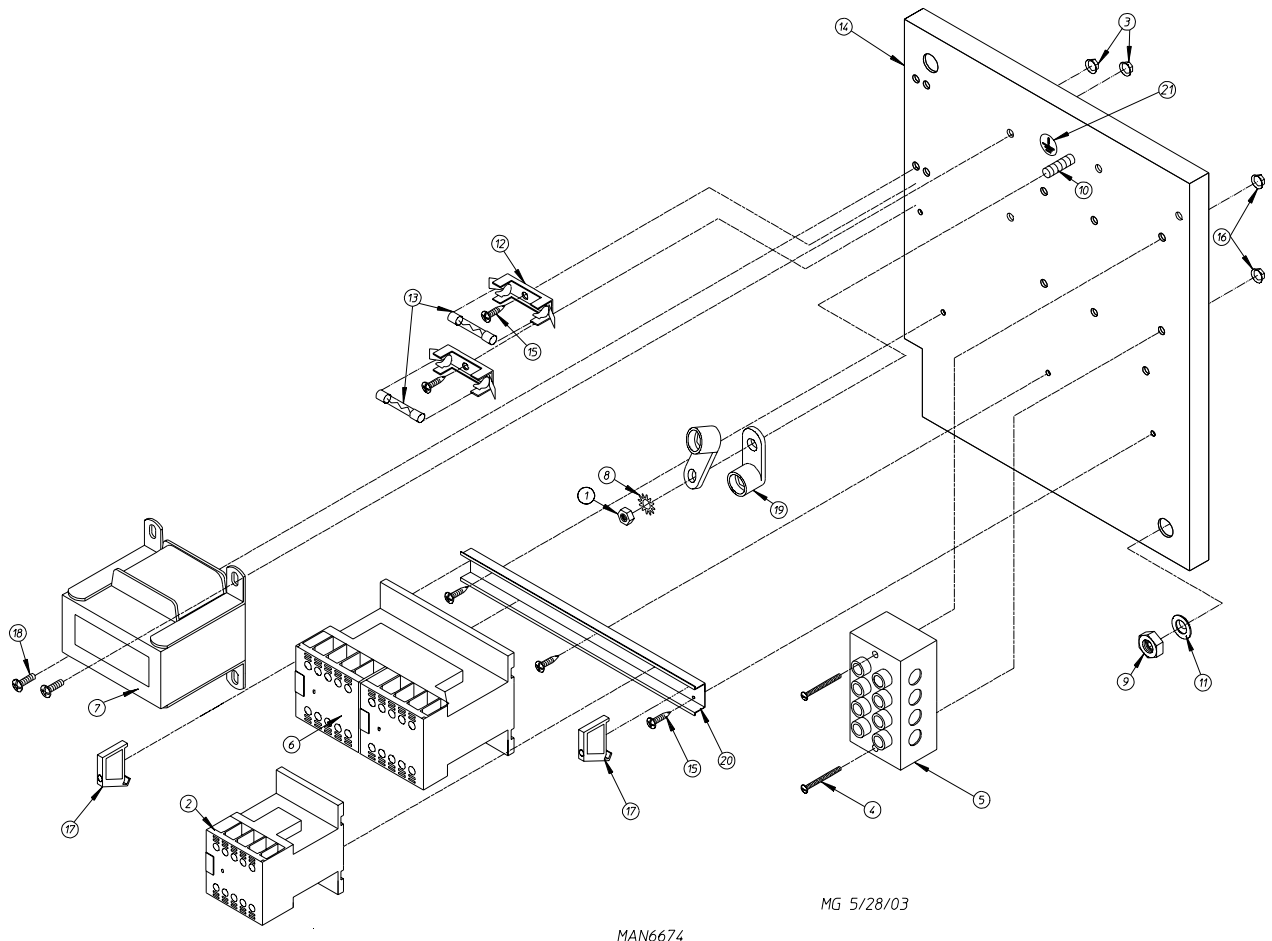

208-240 Volt

For Models Mfd. as of February 3, 2003

<u>Illus. No.</u>	<u>Part No.</u>	<u>Qty.</u>	<u>Description</u>
1	152002	1	1/4-20 Hex Nut
2	132514	1	3ø Contactor with Arc Suppressor
3	151001	2	#8-32 Pal Nut
4	150009	2	#6-32 x 1-1/2" Slotted Round Head Machine Screw
5	120701	1	4 Position Terminal Block
6	132497	1	Reversing Contactor with Arc Suppressor
7	822764	1	208-240v Transformer Assembly
8	153021	1	1/4" Exterior/Interior Shake Proof Washer
9	152004	1	5/16-18 Hex Nut
10	153525	1	1/4-20 x 1" Self-Clinching Stud
11	153002	1	5/16" Lock Washer
12	136008	2	Fuse Holder
13	136057	2	1/2-amp 3AG (Slo-Blo) Fuse
14	332346	1	Relay Panel
15	150301	5	#8-18 x 7/16" Phillips Head TEK Screw
16	151000	2	#6-32 Pal Nut
17	120765	2	End Stop
18	150108	2	#8-32 x 1/2" Phillips Head Machine Screw
19	121010	2	L-70 14-4 Terminal Lug
20	120768	7-3/4"	35 x 15mm Din Rail
21	112075	1	Ground Label
--	112068	1	3ø Input Label...Not Illustrated

44 Microprocessor Reversing Contactor Mounting Panel Assembly (Gas and Steam)

380-416 Volt
For Models Mfd. as of February 3, 2003

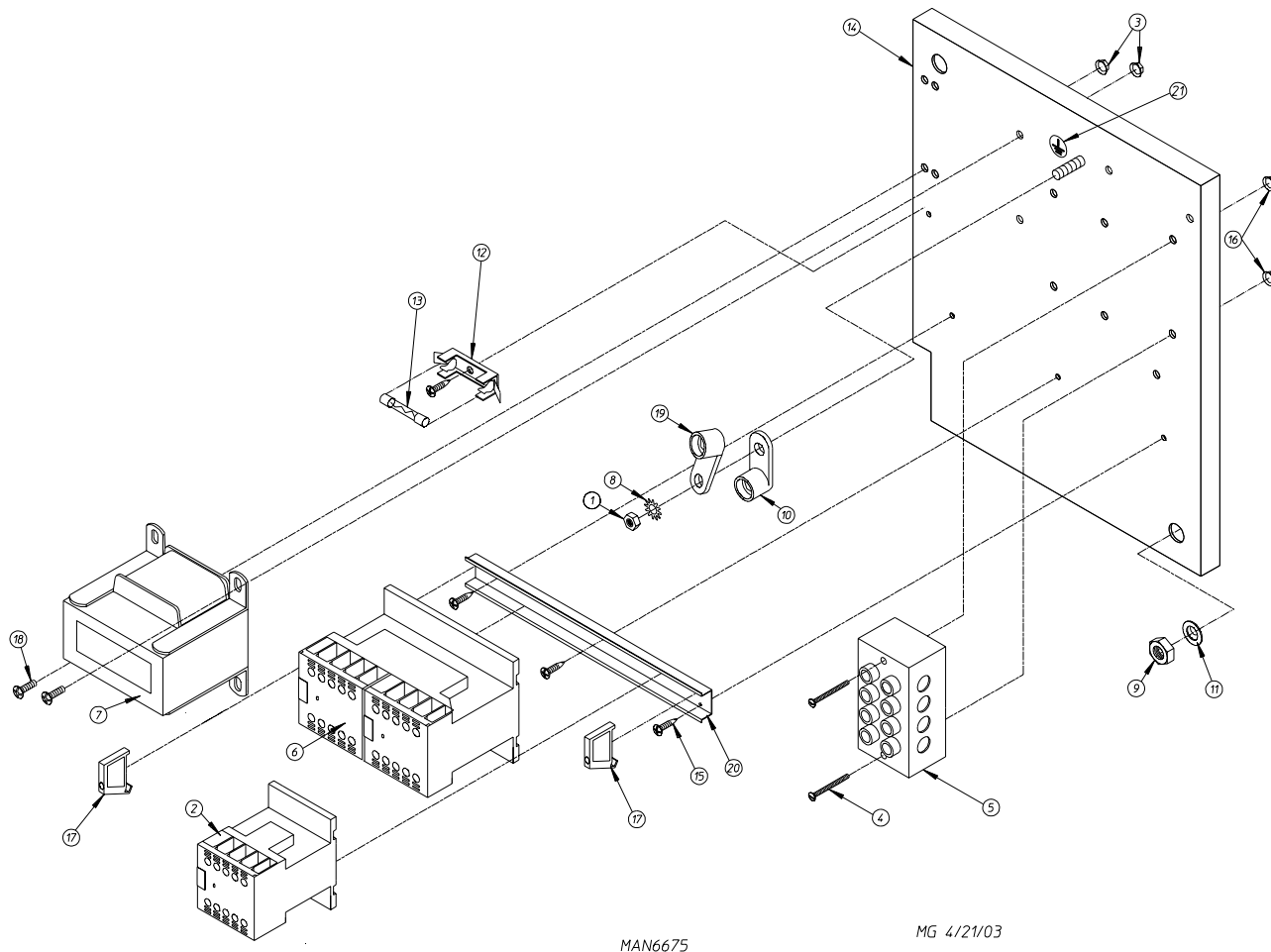

MAN6675

MG 4/21/03

380-416 Volt

For Models Mfd. as of February 3, 2003

<u>Illus. No.</u>	<u>Part No.</u>	<u>Qty.</u>	<u>Description</u>
1	152002	1	1/4-20 Hex Nut
2	132514	1	3ø Contactor with Arc Suppressor
3	151001	2	#8-32 Pal Nut
4	150009	2	#6-32 x 1-1/2" Slotted Round Head Machine Screw
5	120701	1	4 Position Terminal Block
6	132497	1	Reversing Contactor with Arc Suppressor
7	830211	1	380-416V Transformer Assembly
8	153021	1	1/4" Exterior/Interior Shake Proof Washer
9	152004	1	5/16-18 Hex Nut
10	121012	1	Ground Lug
11	153002	1	5/16" Lock Washer
12	136008	1	Fuse Holder
13	136057	1	1/2-amp 3AG (Slo-Blo) Fuse
14	332346	1	Relay Panel
15	150301	4	#8-18 x 7/16" Phillips Head TEK Screw
16	151000	2	#6-32 Pal Nut
17	120765	2	End Stop
18	150108	2	#8-32 x 1/2" Phillips Pan Head Machine Screw
19	121012	1	Ground Lug
20	120768	7-3/4"	35 x 15mm Din Rail
21	112075	1	Ground Label
	112068	1	3ø Input Label

46 Microprocessor Reversing Contactor Mounting Panel Assembly (Gas and Steam)

460-480 Volt
For Models Mfd. as of February 25, 2003

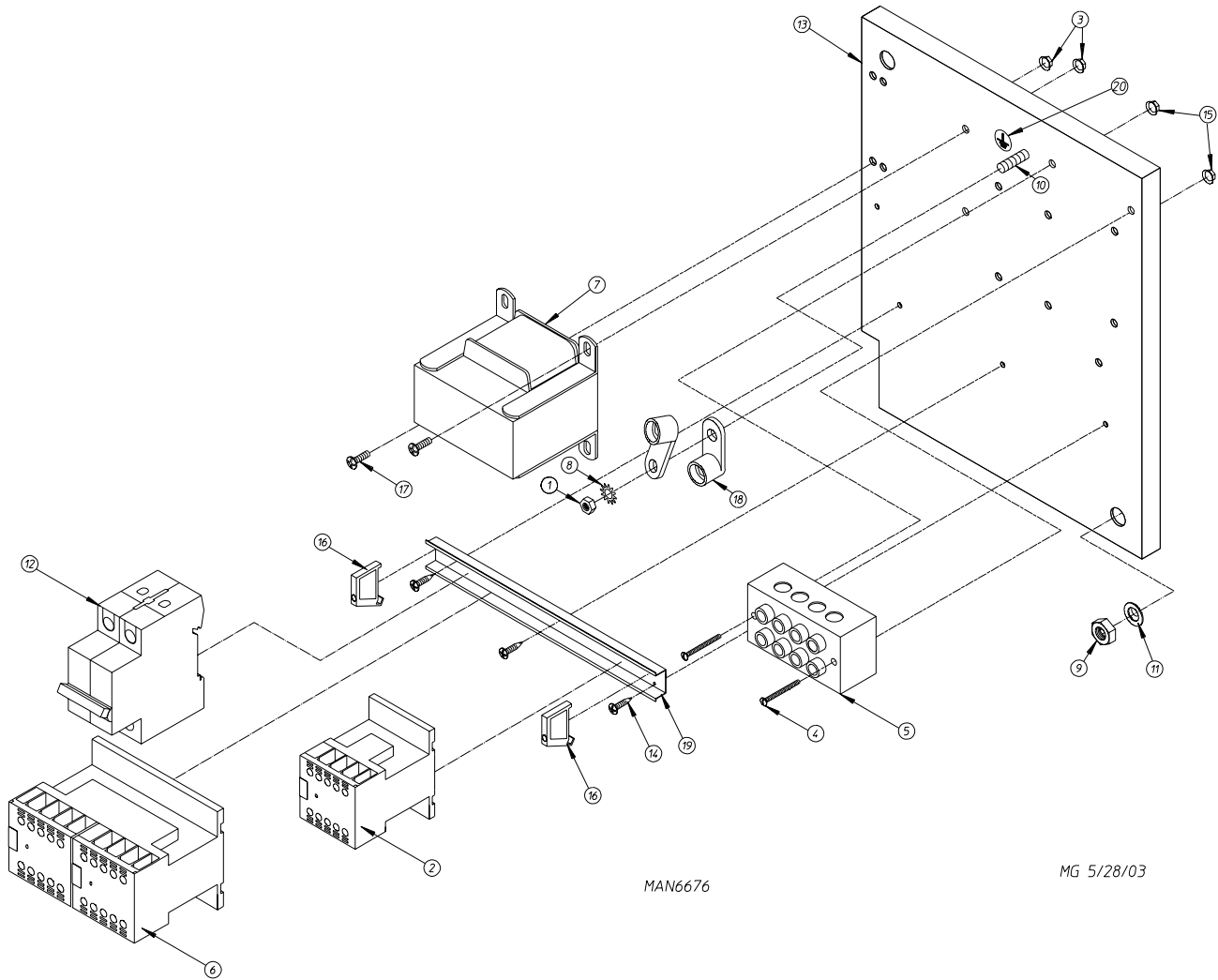

MAN6676

MG 5/28/03

460-480 Volt

For Models Mfd. as of February 25, 2003

<u>Illus. No.</u>	<u>Part No.</u>	<u>Qty.</u>	<u>Description</u>
1	152002	1	1/4-20 Hex Nut
2	132514	1	3ø Contactor with Arc Suppressor
3	151001	2	#8-32 Pal Nut
4	150009	2	#6-32 x 1-1/2" Slotted Round Head Machine Screw
5	120701	1	4 Position Terminal Block
6	132497	1	Reversing Contactor with Arc Suppressor
7	830226	1	460-480V Transformer Assembly
8	153021	1	1/4" Exterior/Interior Shake Proof Washer
9	152004	1	5/16-18 Hex Nut
10	153525	1	1/4-20 x 1" Self-Clinching Stud
11	153002	1	5/16" Lock Washer
12	135501	1	2-Pole 1-amp Circuit Breaker
13	332346	1	Relay Panel
14	150301	3	#8-18 x 7/16" Phillips Head TEK Screw
15	151000	2	#6-32 Pal Nut
16	120765	2	End Stop
17	150108	2	#8-32 x 1/2" Phillips Pan Head Machine Screw
18	121010	2	L-70 14-4 Terminal Lug
19	120768	8-1/4"	35 x 55mm Din Rail
20	112075	1	Ground Label
--	112068	1	3ø Power Input Label...Not Illustrated

For Electric Models ONLY

72 KW OVEN	<i>sl i qp</i>	208		240		380		400		416		480		
	<i>me^pb</i>	3ø		3ø		3ø		3ø		3ø		3ø		
	<i>t fob</i>	3		3		3 or 4		3 or 4		3 or 4		3		
	<i>l sbk=^ppvkm^oq=kl K</i>	802768		802761		802769		802777		---		---		
	<i>bi bj bkqp</i>	<i>nqvK</i>	18		18		---		18		---		---	
		<i>pfwb</i>	4 kW		4 kW		4 kW		---		---		---	
		<i>m^oq=kl K</i>	120010		120011		120073		120010		---		---	
	<i>l sbk-t fob t fqe qboj fk^i i rd</i>	<i>nqvK</i>	---	18'	---	18'	---	---	---	18'	---	---	---	---
		<i>pfwb</i>	#2	#8	#2	#8	#2	#8	#2	#8	---	---	---	---
		<i>m^oq=kl K</i>	883789	883777	883789	883777	883789	883777	883789	883777	---	---	---	---
<i>_rp=^o-m^oq=kl KNONMNG</i>	2'		2'		---		3'		---		---			

* Call factory for information not listed.

60 KW OVEN	<i>sl i qp</i>	---		---		---		---		480		---		
	<i>me^pb</i>	---		---		---		---		3ø		---		
	<i>t fob</i>	---		---		---		---		3		---		
	<i>l sbk=^ppvkm^oq=kl K</i>	---		---		---		---		803872		---		
	<i>bi bj bkqp</i>	<i>nqvK</i>	---		---		---		---		18		---	
		<i>pfwb</i>	---		---		---		---		3.3 kW		---	
		<i>m^oq=kl K</i>	---		---		---		---		120076		---	
	<i>l sbk-t fob t fqe qboj fk^i i rd</i>	<i>nqvK</i>	---	---	---	---	---	---	---	---	---	9'	3'	3'
		<i>pfwb</i>	#2	#8	#2	#8	#1	#8	#1	#8	#2	#8	#8	#8
		<i>m^oq=kl K</i>	---	---	---	---	---	---	---	---	---	883777	883775	883776
<i>_rp=^o-m^oq=kl KNONMNG</i>	---		---		---		---		11'		2.5'' 11''			

* Sold by the foot.

72 kW 208-240 VAC 3 ϕ 50/60 Hz

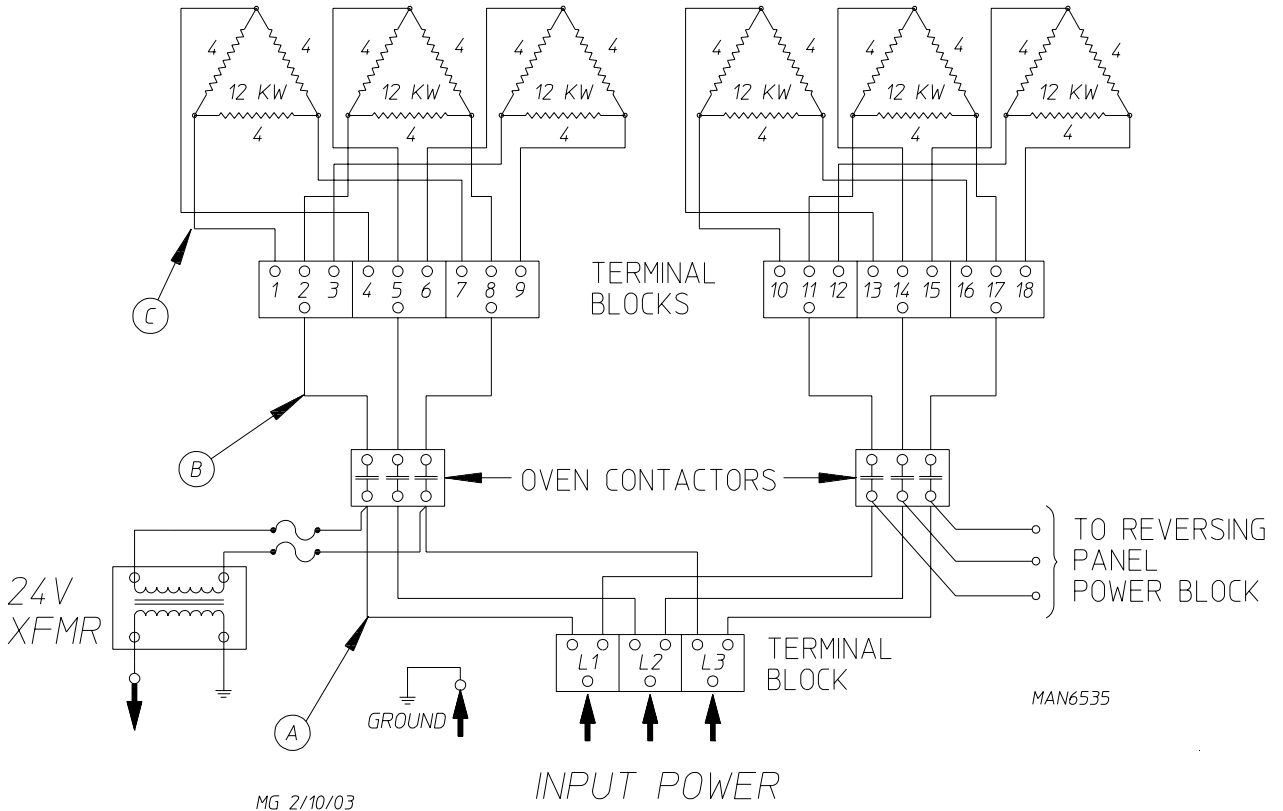

<i>bi b` qof` pbosf` b</i>	<i>nqvK bi bj bkqp</i>	<i>bi bj bkq m^oq krj _bo</i>	<i>l sbk ^j mp</i>	<i>t fob`pfb</i>			<i>`l kq^` ql o</i>	<i>00s^` pqbmal t k qo^kpc l oj bo</i>
				A	B	C		
208v 3 ϕ 3	18	120010	200	2	2	8	131358	883782
240v 3 ϕ 3	18	120011	174	2	2	8	131358	883782

72 kW 380-416/440-480 VAC 3ø 50/60 Hz

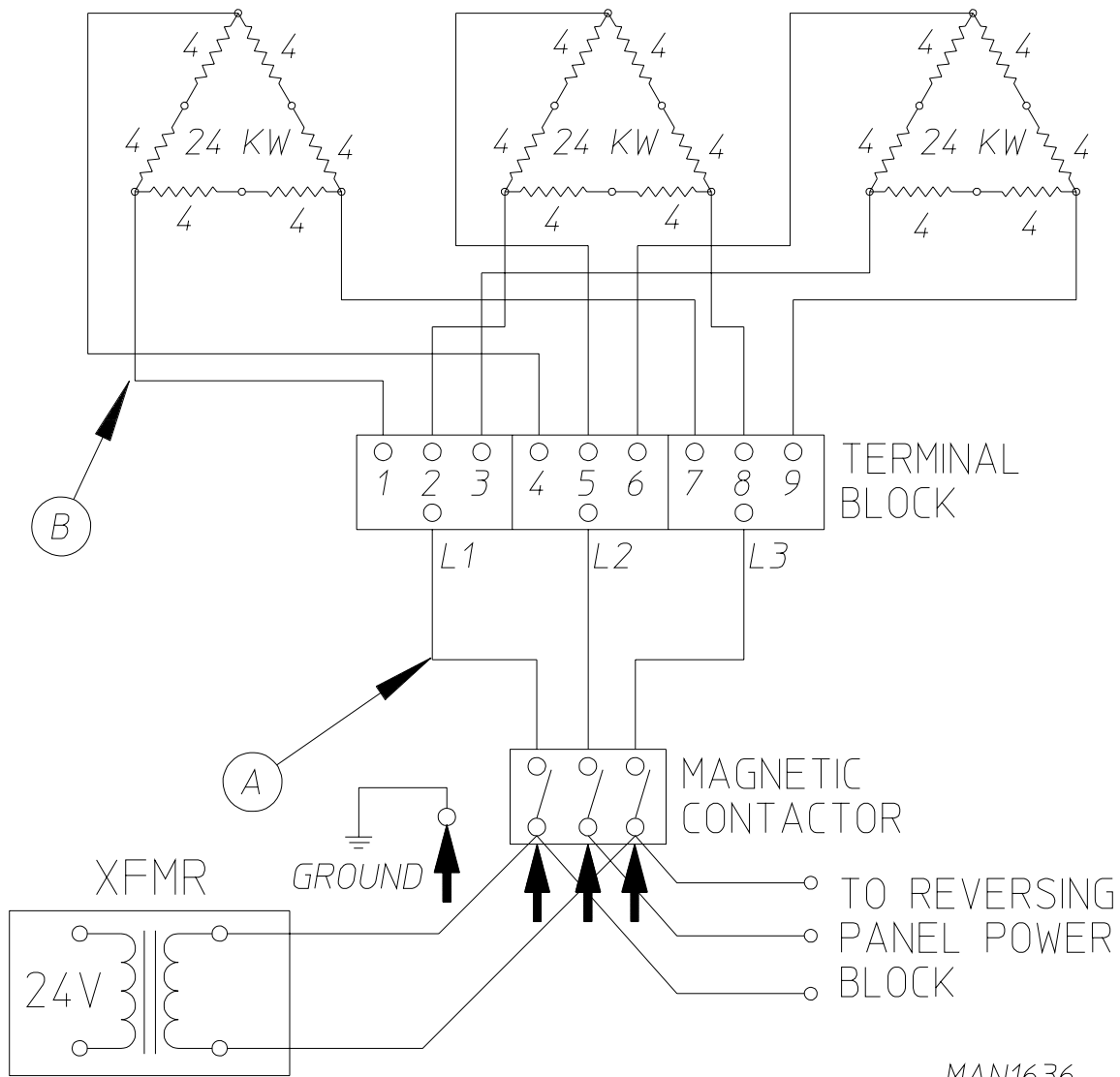

MAN1636

<i>bi b`qof` pbosf`b</i>	<i>nqvK bi bj bkqp</i>	<i>bi bj bkq m^oq krj_bo</i>	<i>l sbk ^j np</i>	<i>t fob=pfwb</i>		<i>`l kq^`ql o</i>	<i>00-s^` pqbm=al t k qo^kpl oj bo</i>
				A	B		
380v 3ø 3,4w	18	120044	110	2	8	131385	132004
400v 3ø 3,4w	18	120010	104	2	8	131358	132004
416v 3ø 3,4w	18	120008	100	2	8	131385	132004
440v 3ø 3,4w	18	120013	100	2	8	131358	132098
480v 3ø 3,4w	18	120009	87	2	8	131385	132004

60 kW 380-416/480 VAC 3ø 50/60 Hz

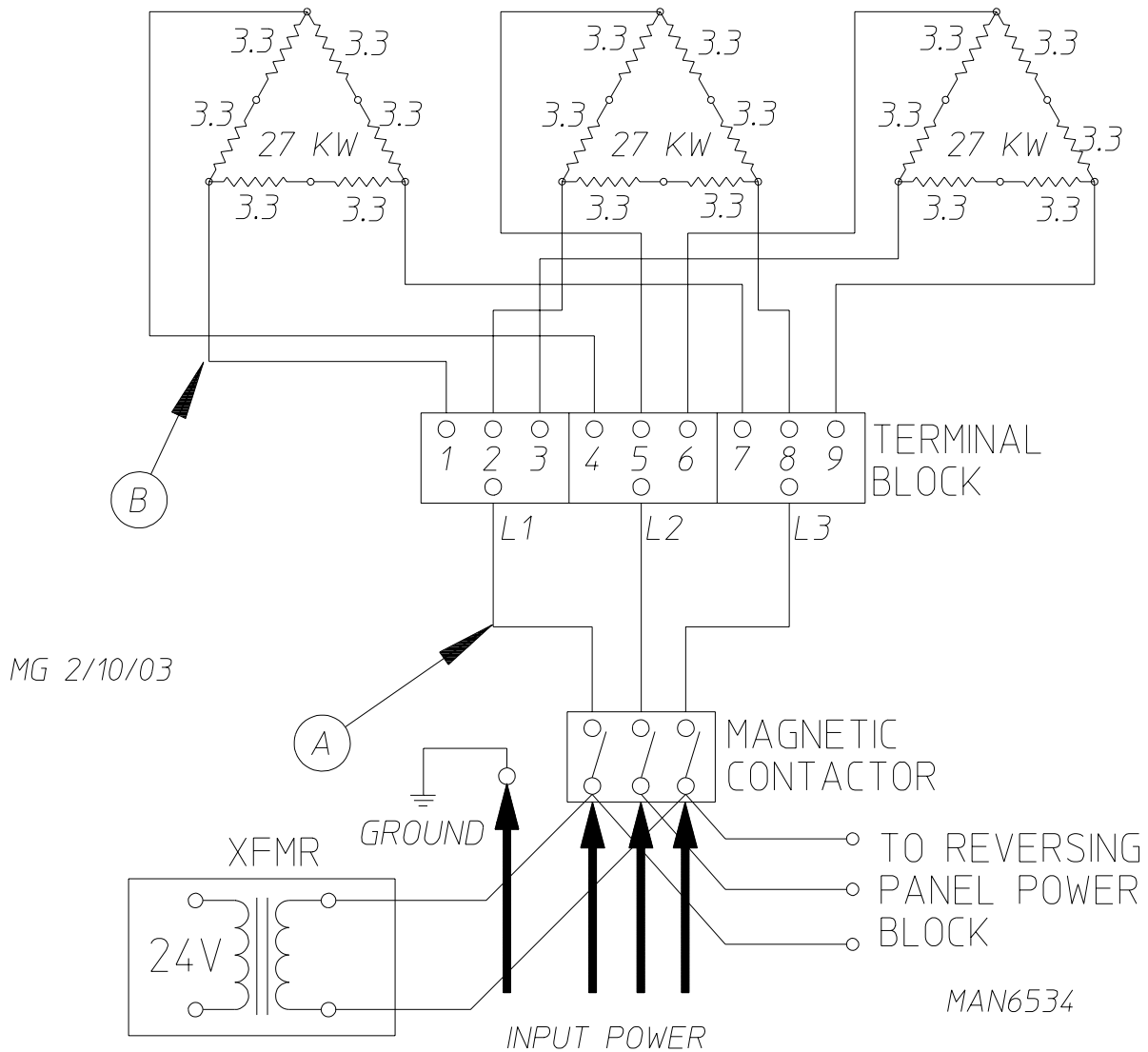

<i>bi b` qof` pbosf` b</i>	<i>nqvK bi bj bkqp</i>	<i>bi bj bkq m^oq krj _bo</i>	<i>l sbk ^j np</i>	<i>t fob=pfwb</i>		<i>`l kq^` ql o</i>	<i>00-s^` pqbm=al t k qo^kpcl oj bo</i>
				A	B		
308v 3ø 3, 4w	---	---	---	---	---	---	---
416v 3ø 3, 4w	---	---	---	---	---	---	---
480v 3ø 3, 4w	18	120076	96.2	2	8	131385	132004

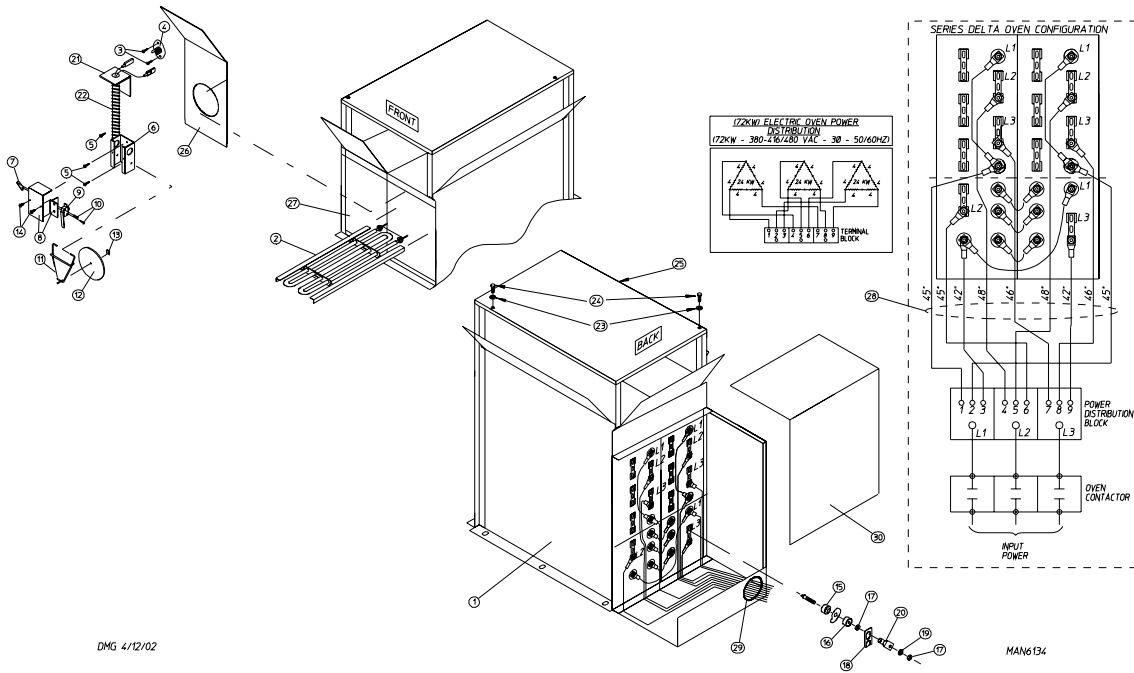

DMG 4/12/02

MAN6134

<u>Illus. No.</u>	<u>Part No.</u>	<u>Qty.</u>	<u>Description</u>
1	816103	1	Electric Oven Box ONLY
2	120011	18	4 kW/240V Open Coil Element (for 240 volt oven)
	120010	18	4 kW/208V Open Coil Element (for 208 volt or 400 volt oven)
	120073	18	4 kW/190V Open Coil Element (for 380 volt oven)
3	150301	2	#8-18 x 7/16" Phillips Pan Head TEK Screw
4	130400	1	290° Hi-Limit ONLY
5	150309	4	#10-16 x 1/2" Hex Head TEK Crimptite Screw
6	319200	1	Sail Switch Box
7	154004	1	Twin Speed Nut
8	802799	1	Sail Switch Box Cover
9	122200	1	Sail Switch ONLY
10	150303	2	#4 x 3/4" Pan Head "A" Machine Screw
11	105500	1	Sail Switch Actuator Rod
12	319202	1	Sail Switch Damper (flat)
13	154002	1	1/8" Push On Fastener
14	150309	28	#10-16 x 1/2" Hex Head TEK Crimptite Screw
15	120081	36	Internal Ceramic Insulator
16	120080	36	External Ceramic Insulator
17	152008	72	#10-32 Hex Nut
18	121011	3'	Bus Bar
19	153009	36	#10 Star Washer
20	121032	36	#8 Rocktherm Connector
21	353222	1	Pipe Bracket
22	815707	1	Hi-Limit and Sail Switch Harness
23	153007	2	1/4" Lock Washer
24	150512	2	1/4-20 x 1/2" Long Bolt
25	819961	1	Burner Cover Assembly
26	321503	1	Right Front Oven Panel
27	321502	1	Left Front Oven Panel
28	815710	1	#8 Oven Assembly Wiring
29	156001	1	Caterpillar Grommet
30	321501	1	Oven Electrical Cover

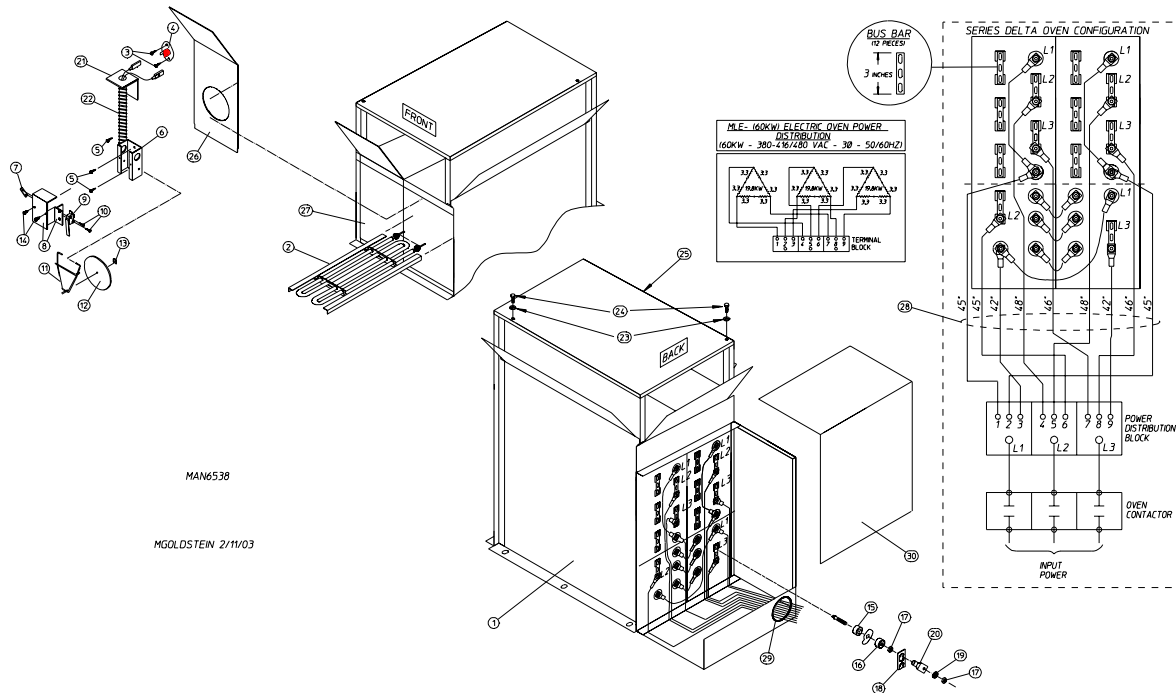

MAN6538

MGOLDSTEIN 2/11/03

Illus. No. Part No. Qty. Description

1	816103	1	Electric Oven Box ONLY
2	120076	18	3.3 kW/240V Open Coil Element
3	150301	2	#8-18 x 7/16" Phillips Pan Head TEK Screw
4	130400	1	290° Hi-Limit ONLY
5	150309	4	#10-16 x 1/2" Hex Head TEK Crimpite Screw
6	319200	1	Sail Switch Box
7	154004	1	Twin Speed Nut
8	802799	1	Sail Switch Box Cover
9	122200	1	Sail Switch Only
10	150303	2	#4 x 3/4" Pan Head "A" Machine Screw
11	105500	1	Sail Switch Actuator Rod
12	319202	1	Sail Switch Damper (flat)
13	154002	1	1/8" Push On Fastener
14	150309	28	#10-16 x 1/2" Hex Head TEK Crimpite Screw
15	120081	36	Internal Ceramic Insulator
16	120080	36	External Ceramic Insulator
17	152008	72	#10-32 Hex Nut
18	121011	3'	Bus Bar
19	153009	36	#10 Star Washer
20	121032	19	#8 Rocktherm Connector
21	353222	1	Pipe Bracket
22	802760	1	Hi-Limit Sail Switch Harness
23	153007	2	1/4" Lock Washer
24	150512	2	1/4-20 x 1/2" Long Bolt
25	819961	1	Burner Cover Assembly
26	331278	1	Right Front Oven Panel
27	331276	1	Left Front Oven Panel
28	815710	1	#8 Oven Assembly Wiring
29	156001	1	Caterpillar Grommet
30	331279	1	Oven Electrical Cover

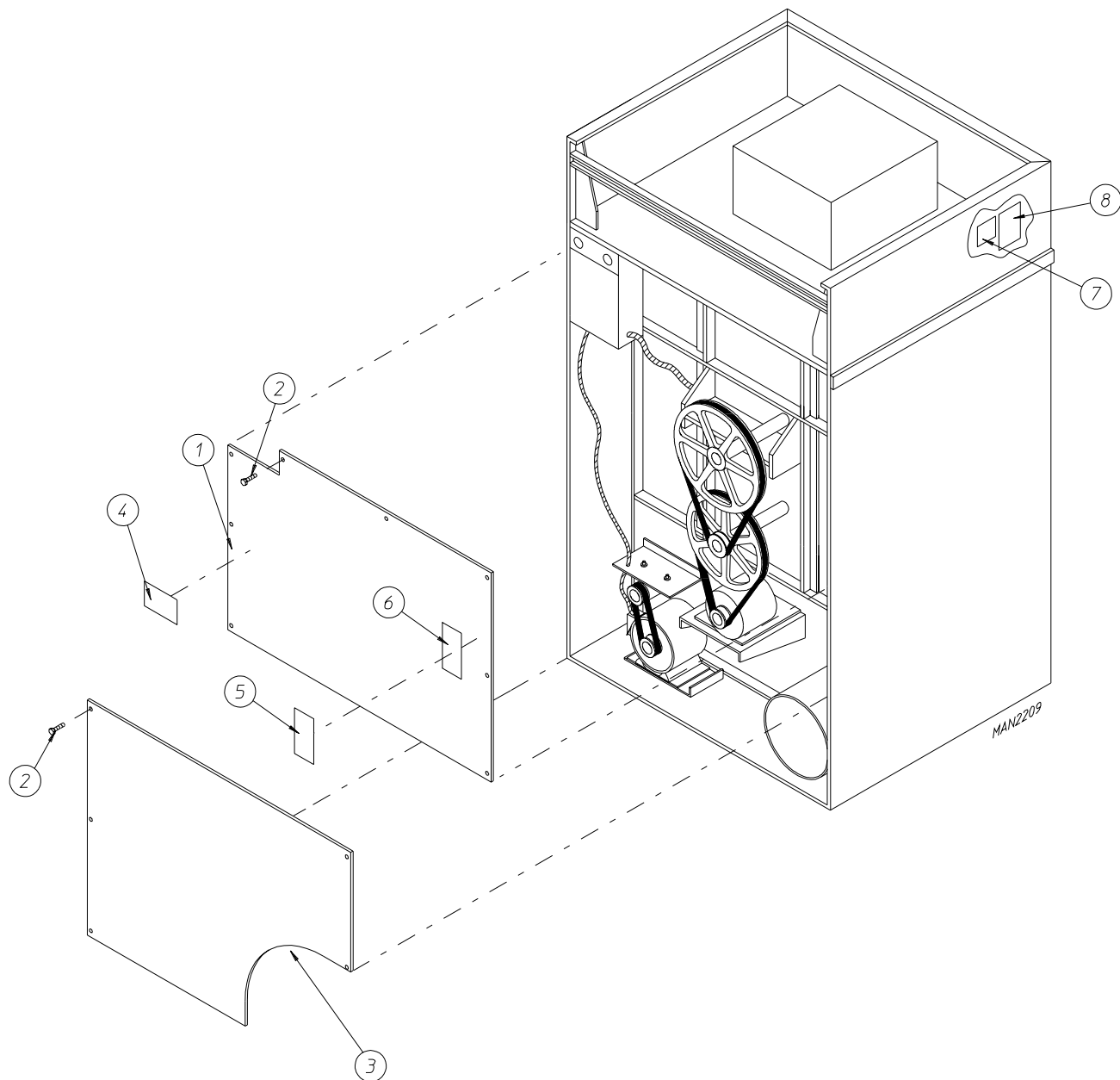

<u>Illus. No.</u>	<u>Part No.</u>	<u>Qty.</u>	<u>Description</u>
1	813029	1	Top Back Guard
2	150301	12	#8-18 x 7/16" Phillips Pan Head TEK Screw
3	354000	1	Gas and Electric Lower Back Guard
	354003	1	Steam Lower Back Guard
4	112017	1	ADC Name and Address Label
5	112229	1	Installation Instructions Label
6	112519	1	Routine Maintenance Label
7	-----	1	Dryer Data Label
8	114521	1	Phase 7 OPL Program Location Label (for microprocessor models Only)

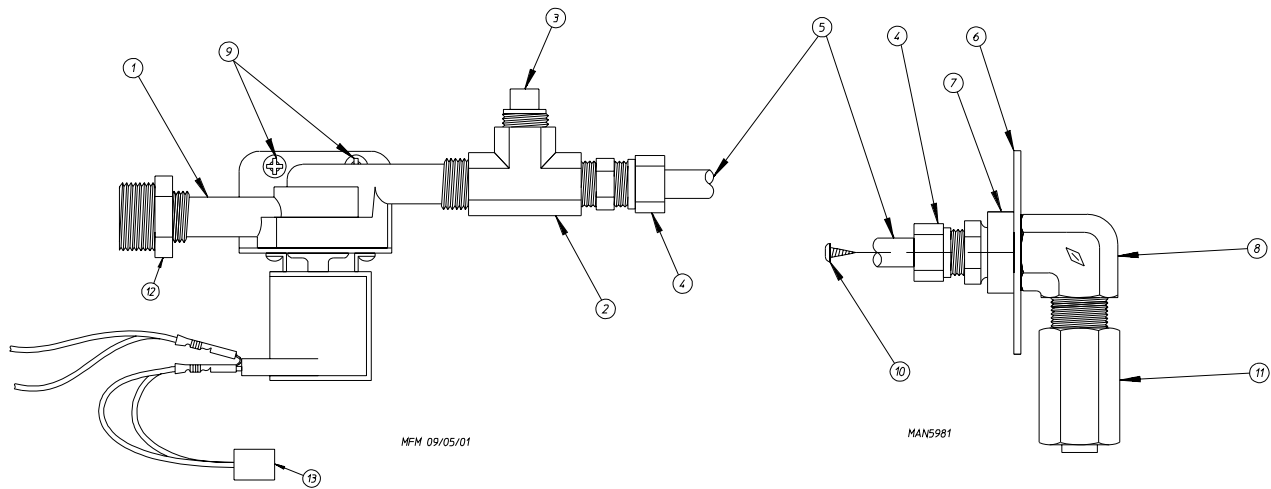

<u>Illus. No.</u>	<u>Part No.</u>	<u>Qty.</u>	<u>Description</u>
1	165114	1	Sensor Activated Fire Extinguishing (S.A.F.E.) System Solenoid Water Valve 24V 50/60 Hz
2	143220	1	3/8" F.P.T. Brass Tee
3	143251	1	3/8" M.P.T. Brass Plug
4	143208	2	3/8" Comp x 3/8" M.P.T. Brass Connector
5	143099*	6'	3/8" OD x 0.035 Wall Copper Tubing
6	311588	1	Sprinkler Head Mounting Plate
7	143303	1	3/8" N.P.T. Brass Locknut
8	143155	1	3/8" Brass Elbow 90°
9	150430	2	#10 x 1/2" Self Drilling Screw
10	150301	2	#8-18 x 7/16" Phillips Pan Head TEK Screw
11	143581	1	3 GPM 3/8" F.P.T. Spray Nozzle
12	142888	1	1/2" to 3/8" Bushing for Sensor Activated Fire Extinguishing (S.A.F.E.) System Valve
13	824828	1	Arc Suppressor

* Sold by the foot.

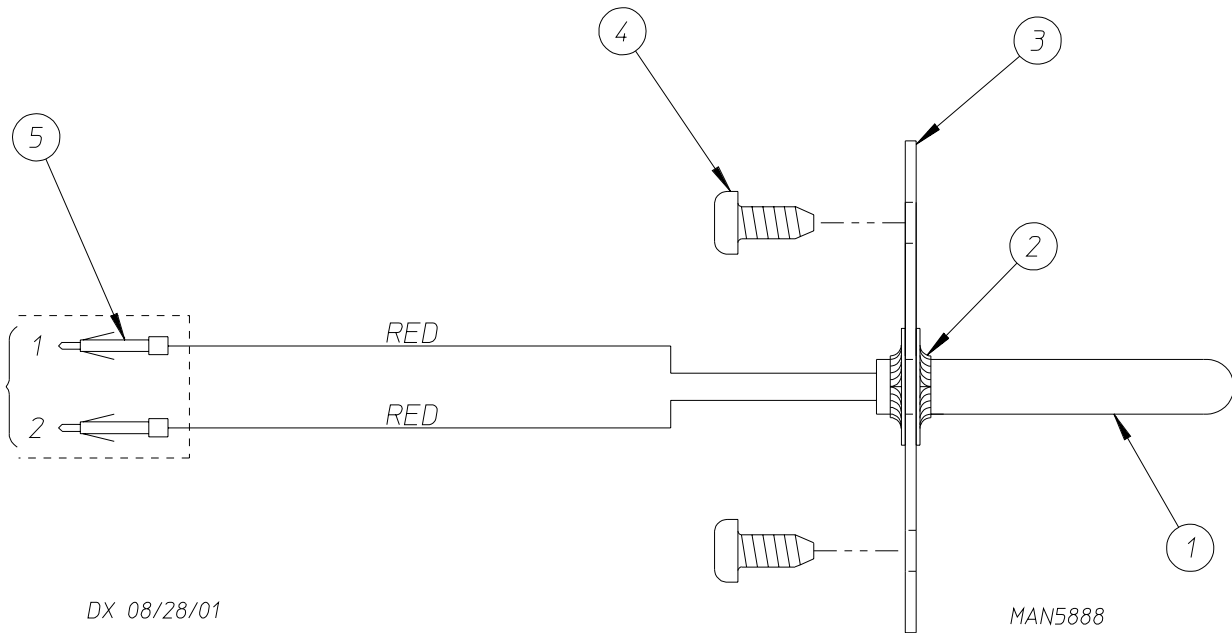

<u>Illus. No.</u>	<u>Part No.</u>	<u>Qty.</u>	<u>Description</u>
1	822752	1	Sensor Activated Fire Extinguishing (S.A.F.E.) System Temperature Probe Assembly (includes illus. nos. 1 through 5)
2	154007	2	Push On Fastener
3	390390	1	Sensor Bracket ONLY
4	150301	2	#8-18 x 7/16" Phillips Pan Head TEK Screw
5	122647	1	Connector ONLY
	122700	2	Pins

