



AD-25V Parts Manual 24 VAC Phase 5

American Dryer Corporation
88 Currant Road
Fall River, MA 02720-4781
Telephone: (508) 678-9000 / Fax: (508) 678-9447
E-mail: techsupport@amdry.com
www.amdry.com

Retain This Manual In A Safe Place For Future Reference

American Dryer Corporation products embody advanced concepts in engineering, design, and safety. If this product is properly maintained, it will provide many years of safe, efficient, and trouble-free operation.

ONLY qualified technicians should service this equipment.

OBSERVE ALL SAFETY PRECAUTIONS displayed on the equipment or specified in the installation manual included with the dryer.

The following “**FOR YOUR SAFETY**” caution **must be** posted near the dryer in a prominent location.

FOR YOUR SAFETY

Do not store or use gasoline or other flammable vapors and liquids in the vicinity of this or any other appliance.

POUR VOTRE SÉCURITÉ

Ne pas entreposer ni utiliser d'essence ni d'autres vapeurs ou liquides inflammables à proximité de cet appareil ou de tout autre appareil.

We have tried to make this manual as complete as possible and hope you will find it useful. **ADC** reserves the right to make changes from time to time, without notice or obligation, in prices, specifications, colors, and material, and to change or discontinue models.

Important

For your convenience, log the following information:

DATE OF PURCHASE _____ **MODEL NO.** _____ **AD-25V**

RESELLER'S NAME _____

Serial Number(s) _____

Replacement parts can be obtained from your reseller or the **ADC** factory. When ordering replacement parts from the factory, you can FAX your order to **ADC** at (508) 678-9447 or telephone your order directly to the **ADC** Parts Department at (508) 678-9000. Please specify the dryer **model number** and **serial number** in addition to the **description** and **part number**, so that your order is processed accurately and promptly.

The illustrations on the following pages may not depict your particular dryer exactly. The illustrations are a composite of the various dryer models. Be sure to check the descriptions of the parts thoroughly before ordering.

“IMPORTANT NOTE TO PURCHASER”

Information **must be** obtained from your local gas supplier on the instructions to be followed if the user smells gas. These instructions **must be** posted in a prominent location near the dryer.

Table of Contents

OPL Control Door Assembly	
For Models Mfd. as of July 1, 2002	3
Coin Control Door Assembly	
For Models Mfd. as of July 1, 2002	4
Control Door Assembly	
For Models Mfd. prior to July 1, 2002	5
Phase 5 Coin Microprocessor Control Panel Assembly	6, 7
Phase 5 OPL Microprocessor Control Panel Assembly	8
Coin and OPL Control Box Assembly	9
Coin Vault Assembly	10
Dual Timer “Tap Touch” Controls	
For Models Mfd. as of November 1, 2000	11
Dual Timer Control Panel Assembly	
For Models Mfd. prior to November 1, 2000	12
Non-Microprocessor Coin Meter Control Panel Assembly	
For Models Mfd. as of January 25, 2002	13
Non-Microprocessor Coin Meter Control Panel Assembly	
For Models Mfd. prior to January 25, 2002	14
Front Panel Assembly	
For Models Mfd. with Steel Main Door as of July 1, 2002	15
Front Panel Assembly	
For Models Mfd. with Steel Main Door prior to July 1, 2002	16
Front Panel Assembly	
For Models Mfd. with Plastic Main Door	17
Main Door “Steel” Assembly	18
Plastic Main Door Assembly	19
Main Door Switch Assembly	
For Models Mfd. with Steel Main Door	20
Main Door Switch	
For Models Mfd. with Plastic Main Door	21
Basket (Tumbler)/Support Assemblies	22

Drop Lint Door Assembly	
For Models Mfd. as of July 1, 2002	23
Lint Trap Assembly	
For Models Mfd. as of July 1, 2002	24
Lint Drawer/Lint Drawer Switch Assembly	
For Models Mfd. between July 25, 2000 and July 1, 2002	25
Lint Drawer/Lint Drawer Switch Assemblies	
For Models Mfd. prior to July 25, 2000	26
Idle Bearing Assembly	27
Basket (Tumbler) Bearing Assembly	28, 29
Non-Reversing Motor Mount Assembly	30, 31
Reversing Motor Mount Assembly	32, 33
Sensor Bracket Assemblies	
For Models Mfd. as of July 1, 2002	34, 35
Sensor Bracket Assemblies	
For Models Mfd. prior to July 1, 2002	36, 37
Gas Burner Assembly	
For Models Mfd. as of September 29, 2000	38, 39
Direct Spark Ignition (DSI) Burner Assembly	
For Models Mfd. prior to September 29, 2000	40, 41
Electric Oven Assembly	42, 43
Sail Switch/Hi-Limit Assemblies	44
Single-Phase (1 ϕ) Motor, Electric Relay Panel Assembly	45
3-Phase (3 ϕ) Motor, Electric Relay Panel Assembly	46
460-480 VAC 3-Phase (3 ϕ) Motor, Electric Relay Panel Assembly	47
Reversing Electric Relay Panel Assembly	48
460-480 VAC Reversing Electric Relay Panel Assembly	49
Steam Coil/Air Operated Steam Damper Assembly	50, 51
Steam Coil/Mechanical Steam Damper Assembly	52, 53
Outer Top/Back Guard Assemblies	54
Microprocessor Coin Acceptors Listing	55
Coin Meter Replacement Parts	56
Electrical Oven Component Application Chart	57
Additional Parts Available	58

For Models Mfd. as of July 1, 2002

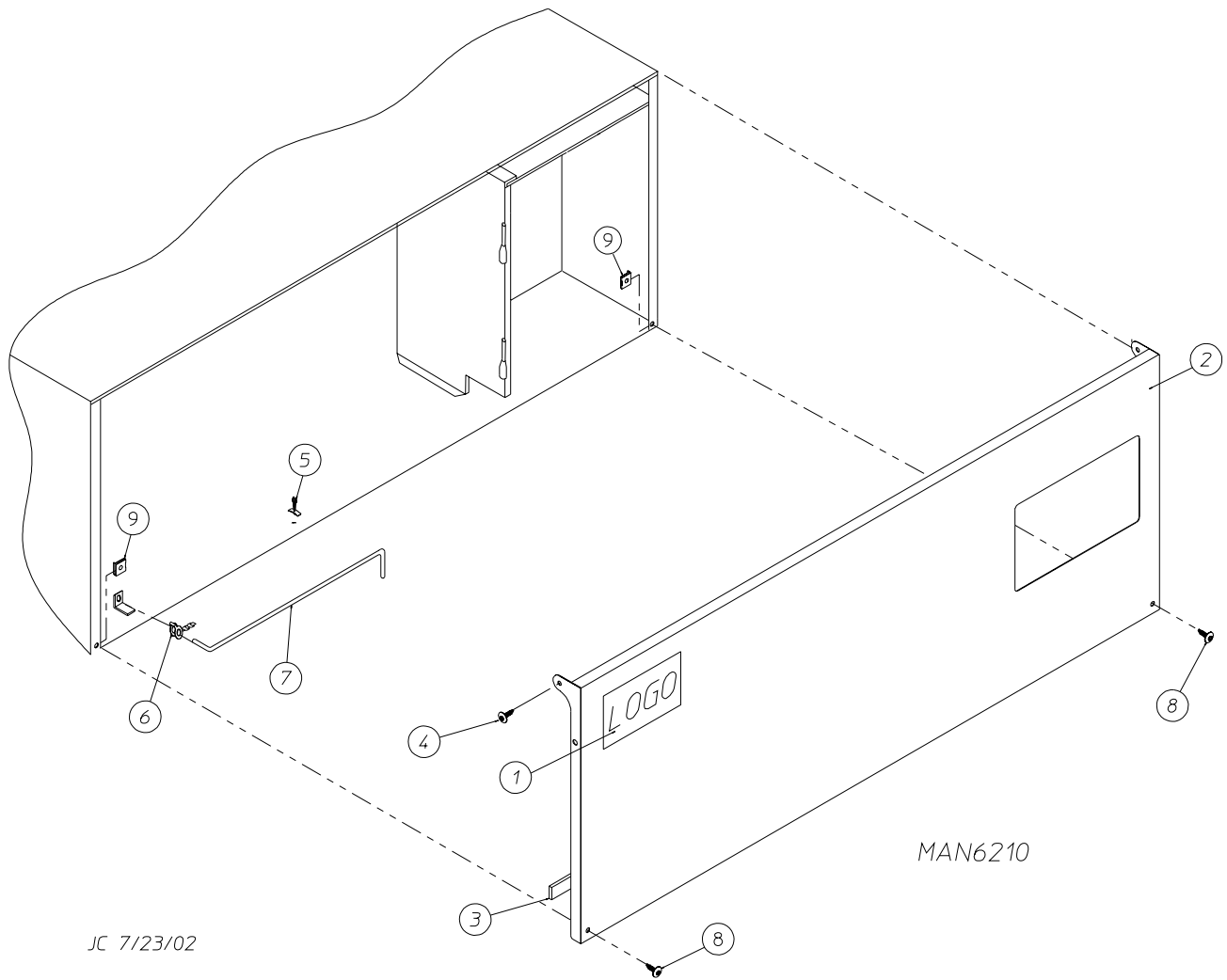

<u>Illus. No.</u>	<u>Part No.</u>	<u>Qty.</u>	<u>Description</u>
1	881053	1	ADC Logo with Tape
	870011	1	Double Sided Tape Kit
2	883550	1	White Control Door Assembly (includes illus. nos. 2 and 3)
	883551	1	Ivory Control Door Assembly (includes illus. nos. 2 and 3)
	883552	1	Coral Blue Control Door Assembly (includes illus. nos. 2 and 3)
3	117604	3	Sponge Tape (sold by the foot)
4	150317	2	#10-16 x 3/4" TORX + BTN Type 1
5	102603	1	Control Door Rod Support Catch
6	102601	1	Control Door Rod Retainer Clip
7	102502	1	Control Door Support Rod
8	150321	2	#10-32 x 1/2" Phillips Machine Screw
9	154011	2	#10-32 Multi-Thread U-Nut

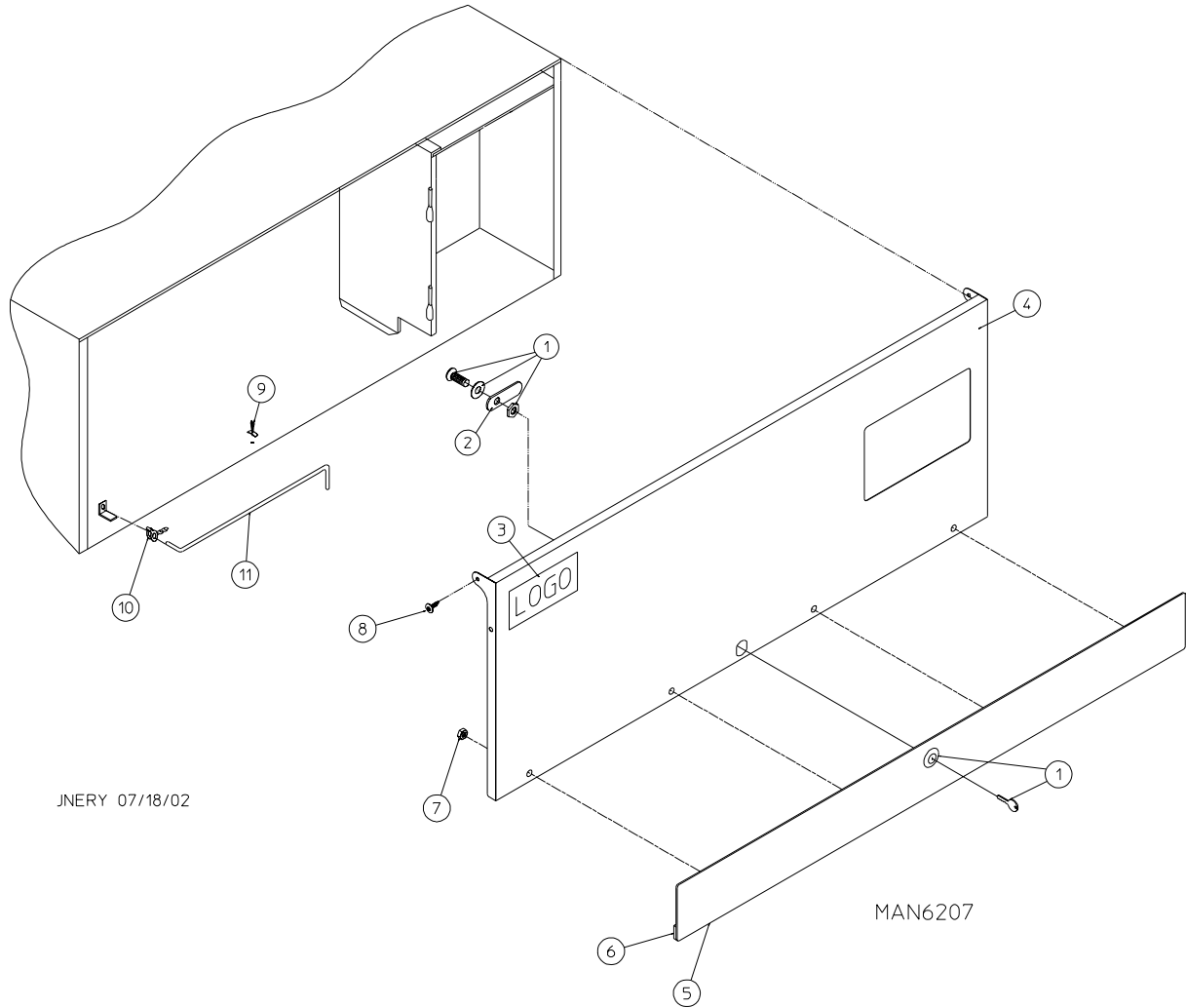

<u>Illus. No.</u>	<u>Part No.</u>	<u>Qty.</u>	<u>Description</u>
1	160015	1	High Security Lock Assembly
	160104	1	Key ONLY
2	160016	1	Lock Cam ONLY
3	881053	1	ADC Logo with Tape
4	883477	1	White Control Door Assembly with Black Trim (includes illus. nos. 4 through 7)
	883478	1	Ivory Control Door with Black Trim (includes illus. nos. 4 through 7)
	883549	1	Coral Blue Control Door with Black Trim (includes illus. nos. 4 through 7)
5	883476	1	Black Trim Strip with Lock Hole
6	117604	6	Sponge Tape (sold by the foot)
7	152014	4	1/4-20 with 3/4" Free Spin Wash Nut
8	150317	2	#10-16 x 3/4" TORX + BTN Type 1
9	102603	1	Control Door Rod Support Catch
10	102601	1	Control Door Rod Retainer Clip
11	102502	1	Control Door Support Rod

For Models Mfd. prior to July 1, 2002

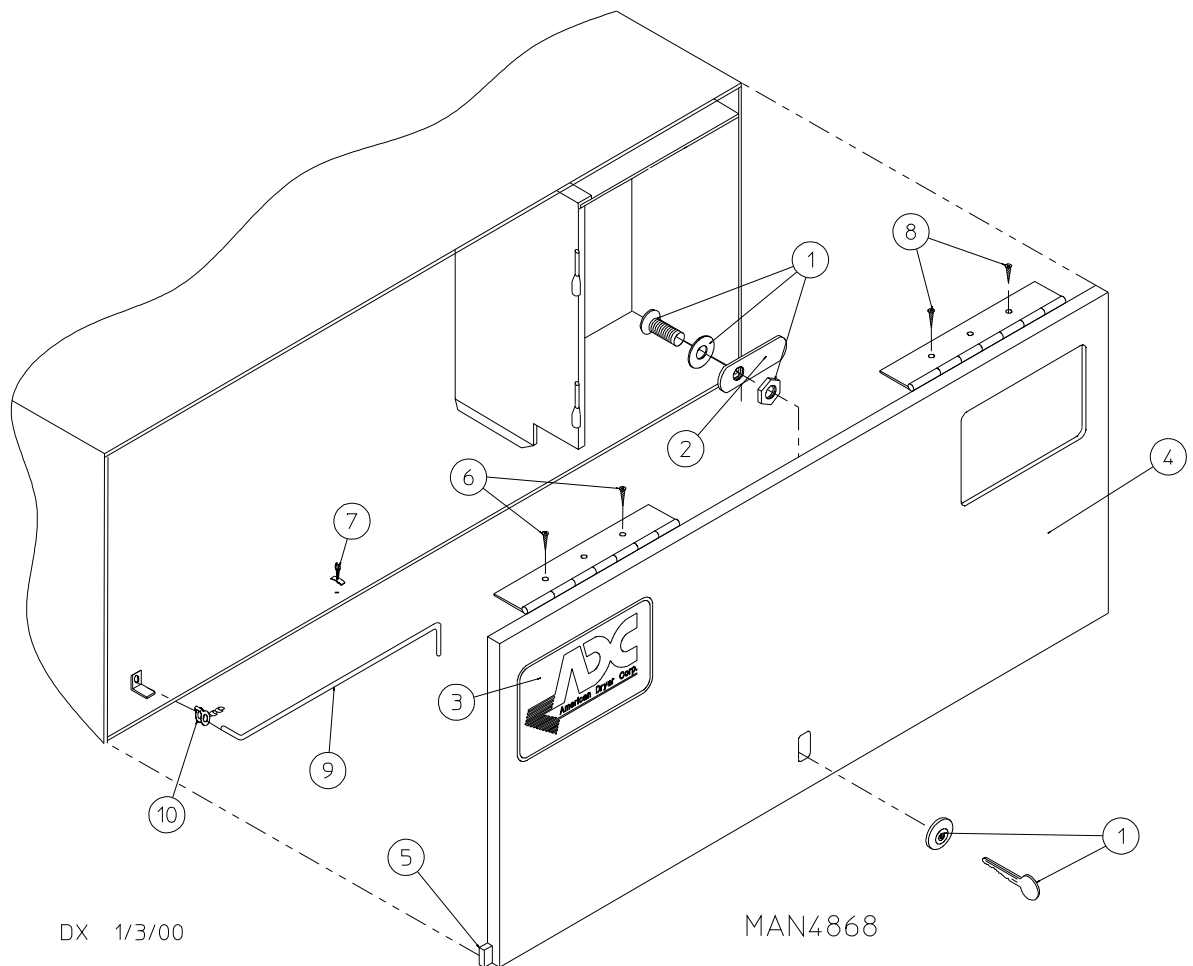

<u>Illus. No.</u>	<u>Part No.</u>	<u>Qty.</u>	<u>Description</u>
1	160015	1	High Security MK-100 Lock Assembly with Key (for coin models Only)
	160017	1	Special Dummy Lock ONLY (for non-coin models Only)
	160104	1	MK-100 Key ONLY
2	160052	1	Lock Cam ONLY
3	881053	1	ADC Logo with Tape
	870011	1	Double Sided Tape Kit
4	882511	1	White Control Door Assembly Less Lock (includes illus. nos. 4 and 5)
	882513	1	Almond B Control Door Assembly Less Lock (includes illus. nos. 4 and 5)
	882512	1	Coral Blue Control Door Assembly Less Lock (includes illus. nos. 4 and 5)
5	117603	3	Noise Suppressor Tape (sold by the foot)
6	150300	2	#10-16 x 1/2" Hex Washer TEK Screw
7	102603	1	Control Door Rod Support Catch
8	150300	2	#10-16 x 1/2" Hex Washer TEK Screw
9	102502	1	Control Door Support Rod
10	102601	1	Control Door Rod Retainer Clip

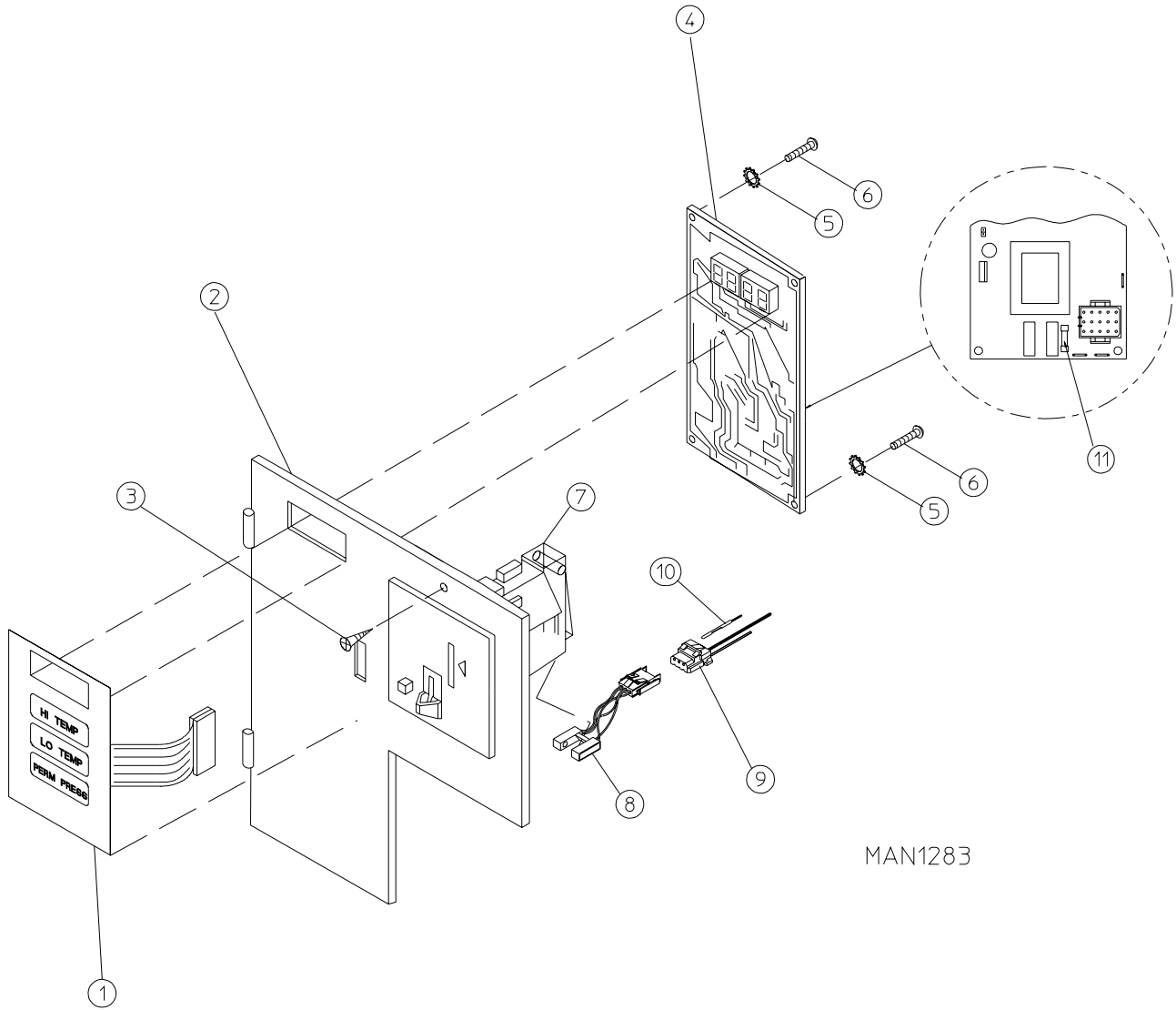

MAN1283

<u>Illus. No.</u>	<u>Part No.</u>	<u>Qty.</u>	<u>Description</u>
1	112526	1	Coin Keyboard Label Assembly
2	883537	1	Phase 5 Coin Control Panel Assembly (includes illus. nos. 1, 2, and 4 through 6) (for models mfd. as of June 25, 2002)
	883538	1	Phase 5 Coin Control Panel Assembly with Battery Option (includes illus. nos. 1, 2, and 4 through 6) (for models mfd. as of June 25, 2002)
	883582	1	Phase 5 Coin Control Panel Assembly with Battery Option (includes illus. nos. 1, 2, and 4 through 6) (for models mfd. prior to June 25, 2002)
	883581	1	Phase 5 Coin Control Panel Assembly (includes illus. nos. 1, 2, and 4 through 6) (for models mfd. prior to June 25, 2002)
	883539	1	Coin Control Panel ONLY (for models mfd. as of June 25, 2002)
	883540	1	Coin Control Panel ONLY with Battery Bracket (for models mfd. as of June 25, 2002)
	883580	1	Coin Control Panel ONLY (for models mfd. prior to June 25, 2002)
	883579	1	Coin Control Panel ONLY with Battery Bracket (for models mfd. prior to June 25, 2002)
3	150309	1	#10-16 x 1/2" Hex Head TEK Crimptite Screw
4	137213	1	Phase 5 Coin Controller ONLY
	824998	1	Phase 5 Battery Clip
5	153010	2	#6 Star Washer
6	150005	2	#6-32 x 1/4" Phillips Round Head Machine Screw
7	-----	1	Microprocessor Coin Acceptor (refer to Microprocessor Coin Acceptors Listing on page 55)
8	-----	1	Optic Switch ONLY (refer to Microprocessor Coin Acceptors Listing on page 55)
9	137023	1	Optic Switch Connector ONLY
10	137021	3	Microprocessor Socket ONLY
	880772	1	Single Coin Optical Switch Harness
	122800	1	Microprocessor (female) Pin Extraction Tool
11	136048	1	1/8-Amp (Slo-Blo) Fuse

IMPORTANT: Check label on computer chip to verify correct part number of controller (computer).

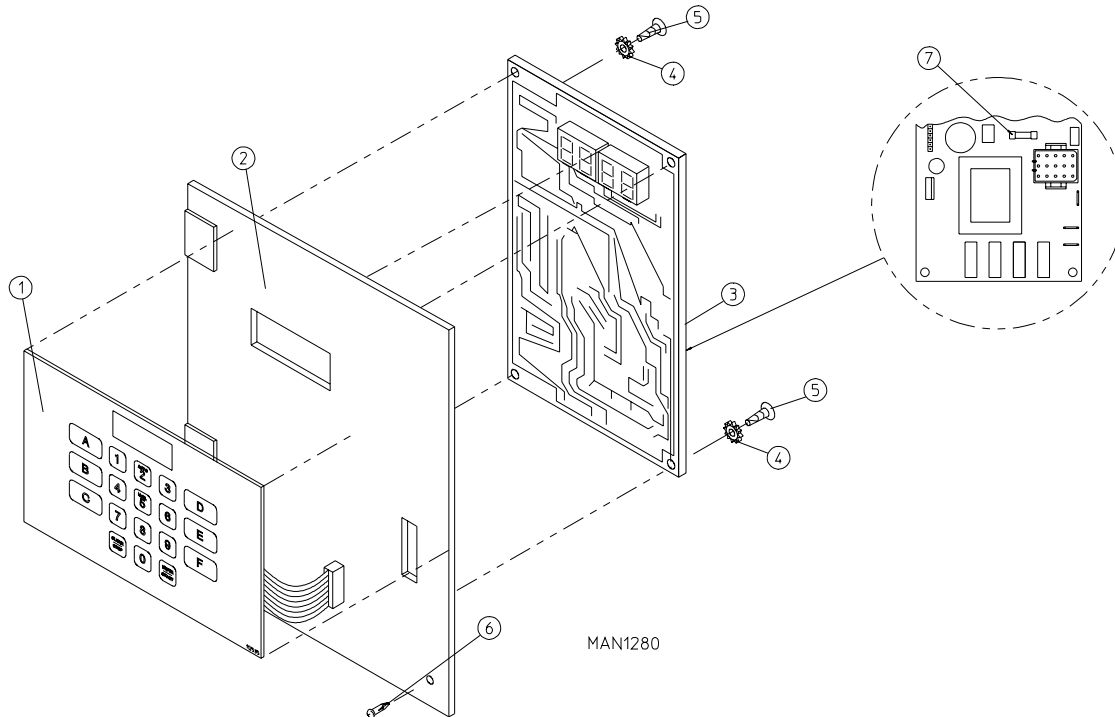

<u>Illus. No.</u>	<u>Part No.</u>	<u>Qty.</u>	<u>Description</u>
1	112535	1	OPL English Keyboard Label Assembly
	112276	1	OPL Stick-On Labels (English Only)...Not Illustrated
	112275	1	3-Language OPL Stick-On Labels (Spanish, Italian, and Hebrew)...Not Illustrated
	112277	1	3-Language OPL Stick-On Labels (English, Spanish, and Hebrew)...Not Illustrated
	112278	1	5-Language OPL Stick-On Labels (Italian, Dutch, French, German, and Chinese)...Not Illustrated
2	801255	1	Phase 5 Microprocessor Control Panel ONLY
	801256	1	Phase 5 Microprocessor Control Panel ONLY with Battery Bracket
	801206	1	Phase 5 OPL Non-Reversing Microprocessor Control Panel Assembly Complete (includes illus. nos. 1 through 5)
	801207	1	Phase 5 OPL Reversing Microprocessor Control Panel Assembly Complete (includes illus. nos. 1 through 5)
3	137222	1	Phase 5 OPL Non-Reversing Controller ONLY
	137231	1	Phase 5 OPL Reversing Controller ONLY
	824998	1	Phase 5 Battery Clip
4	153010	2	#6 Star Washer
5	150005	2	#6-32 x 1/4" Phillips Round Head Machine Screw
6	150309	1	#10-16 x 1/2" Hex Head TEK Crimptite Screw
7	136048	1	1/8-Amp (Slo-Blo) Fuse

IMPORTANT: Check label on computer chip to verify correct part number for controller (computer).

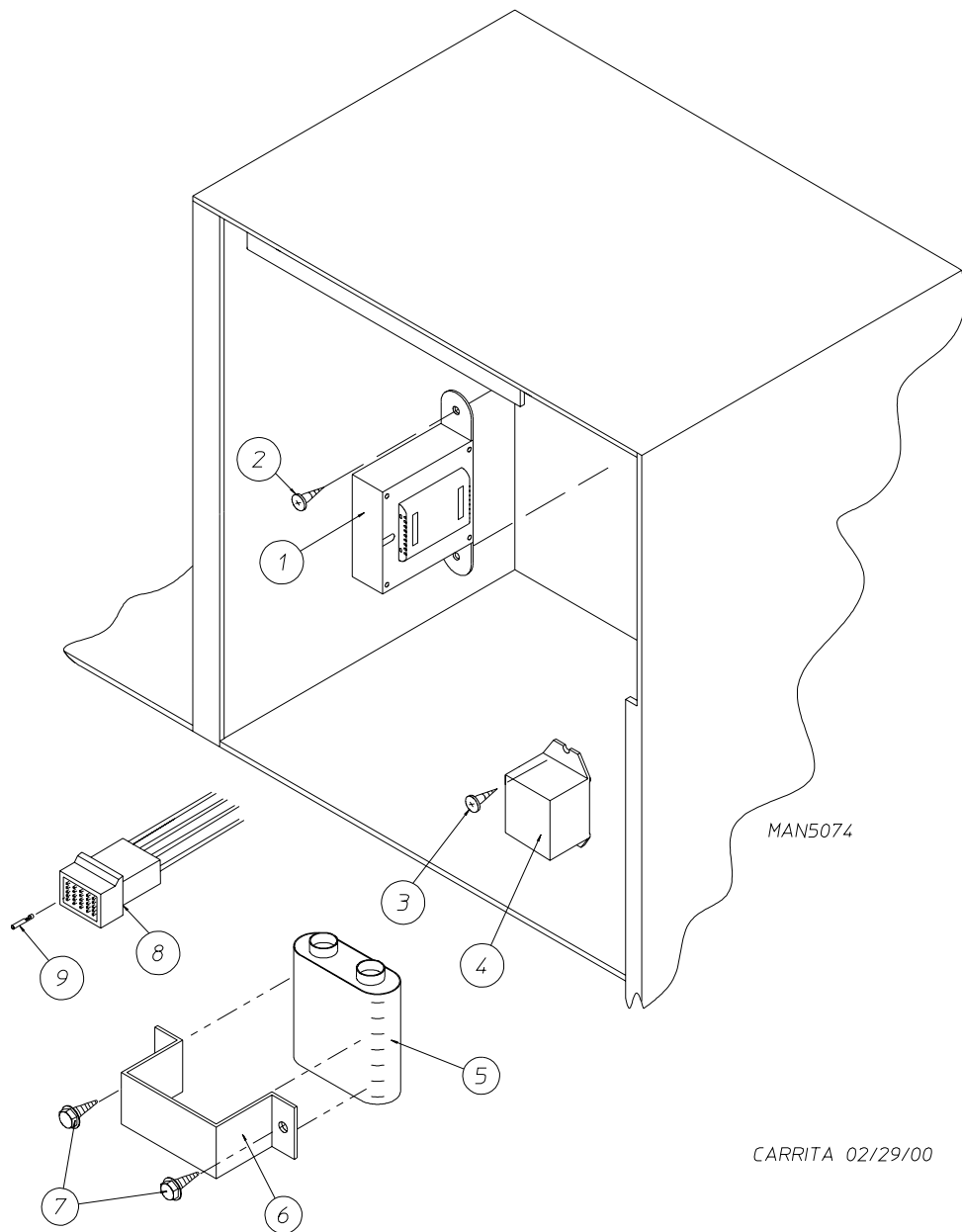

<u>Illus. No.</u>	<u>Part No.</u>	<u>Qty.</u>	<u>Description</u>
1	132002	1	Transformer (for mechanical steam dampers 208 VAC and higher)
2	150300	2	#10-16 x 1/2" Hex Washer TEK Screw
3	150301	2	#8 x 7/16" Phillips Pan Head TEK Screw
4	131931	1	Steam Valve Relay - 24 VAC (for mechanical steam damper models Only)
5	137035	1	Motor Capacitor (for mechanical steam damper models Only)
6	323583	1	Capacitor Bracket (for mechanical steam damper models Only)
7	150300	2	#10-16 x 1/2" Hex Washer TEK Screw
8	122641	1	15-Pin Microprocessor Connector
9	122706	*	Socket Terminal ONLY
--	122801	1	Pin/Socket Extraction Tool

* As required.

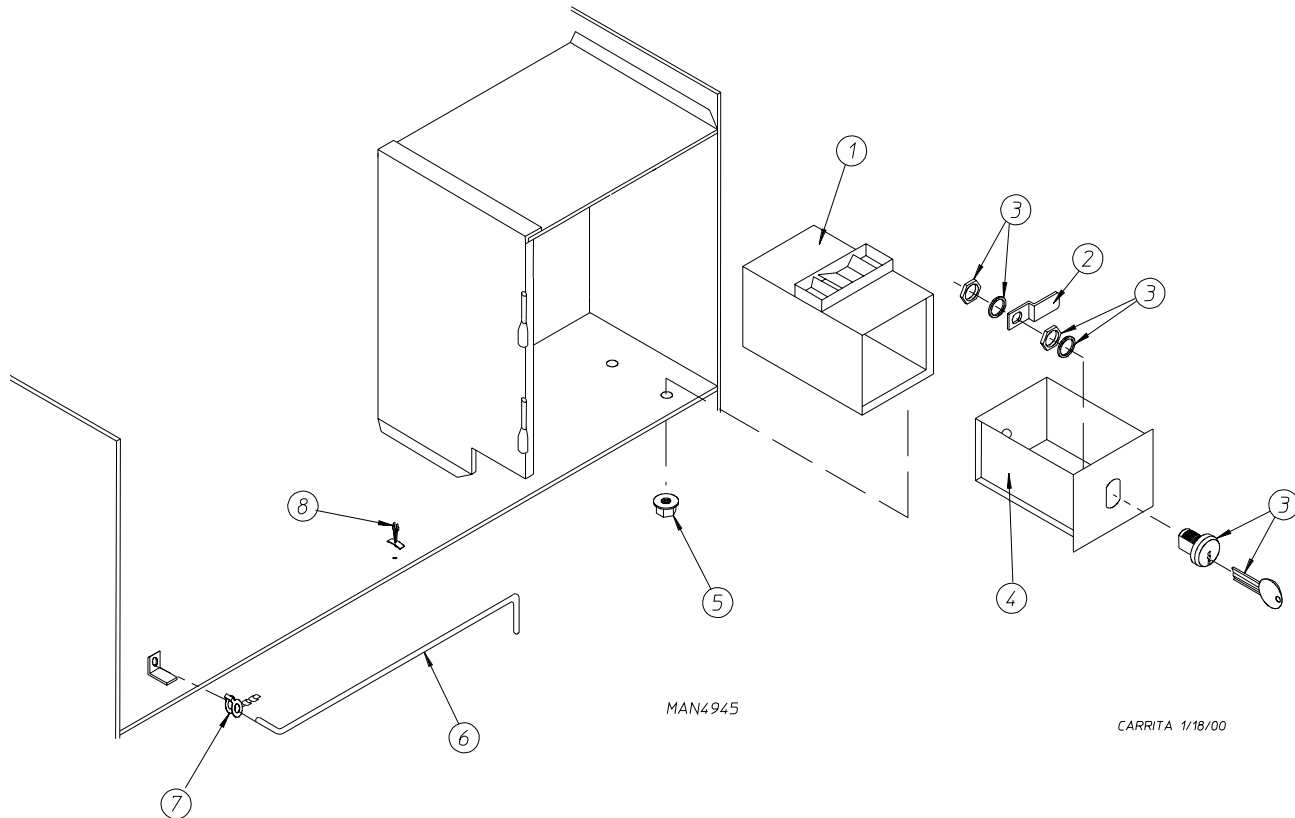

<u>Illus. No.</u>	<u>Part No.</u>	<u>Qty.</u>	<u>Description</u>
1	802112	1	Microprocessor Coin Vault Assembly Complete (includes illus. nos. 1 through 5)
	802117	1	Microprocessor Coin Vault ONLY
	802110	1	Non-Microprocessor Coin Vault Assembly Complete (includes illus. nos. 1 through 5)
	802115	1	Non-Microprocessor Coin Vault ONLY
2	160028	1	Cam for 1/4 Turn Lock ONLY
3	875061	1	1/4 Turn Lock with Key and Cam
	160105*	1	1/4 Turn Mer-Pel Key ONLY
4	802020	1	1/4 Turn Coin Box Assembly (includes illus. nos. 2 through 4)
5	152014	4	1/4-20 Free Spin Wash Nut
6	102502	1	Control Door Support Rod
7	102601	1	Control Door Rod Retainer Clip
8	102603	1	Control Door Rod Catch

* Specify key number when ordering.

For Models Mfd. as of November 1, 2000

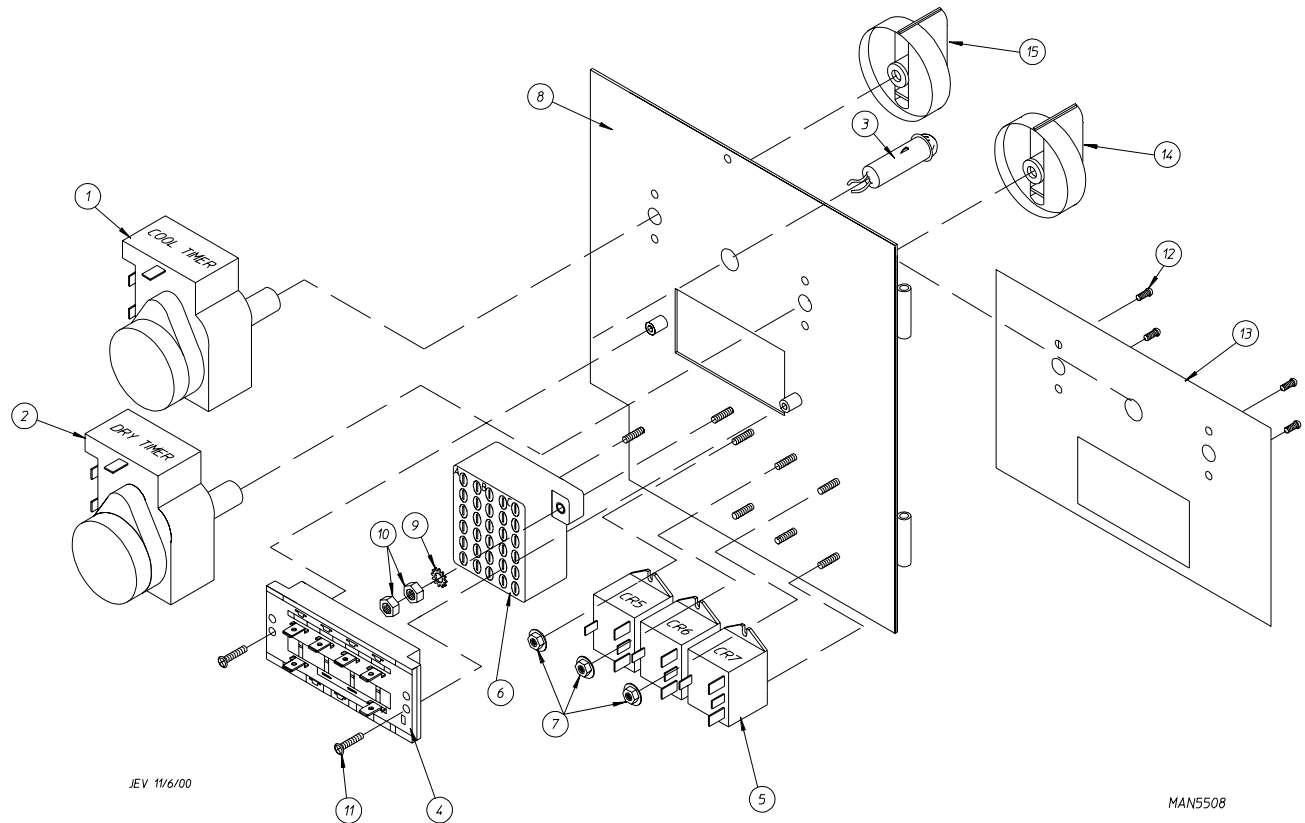

<u>Illus. No.</u>	<u>Part No.</u>	<u>Qty.</u>	<u>Description</u>
1	824298	1	15 Minute Timer - 24 VAC
2	824299	1	60 Minute Timer - 24 VAC
3	824175	1	Red Pilot Light - 24 VAC
4	122301	1	"Tap Touch" Switch
5	131932	3	Relay SPST 24v
6	120730	1	30-Position Terminal Block
7	151000	6	#6-32 Pal Nut
8	882903	1	Dual Timer Panel Complete (includes illus. nos. 1 through 15)
	850392	-	Dual Timer Panel ONLY
9	153010	2	#6 Star Washer
10	152000	3	#6-32 Hex Nut
11	150207	2	#10-24 x 1/2" Phillips Pan Head Machine Screw
12	150110	4	#8-32 x 1/4" Phillips Round Head Machine Screw
13	112563	1	Dual Timer Panel Overlay
14	124104	1	Pure Touch Knob with Red Pointer
15	124105	1	Pure Touch Knob with Blue Pointer

For Models Mfd. prior to November 1, 2000

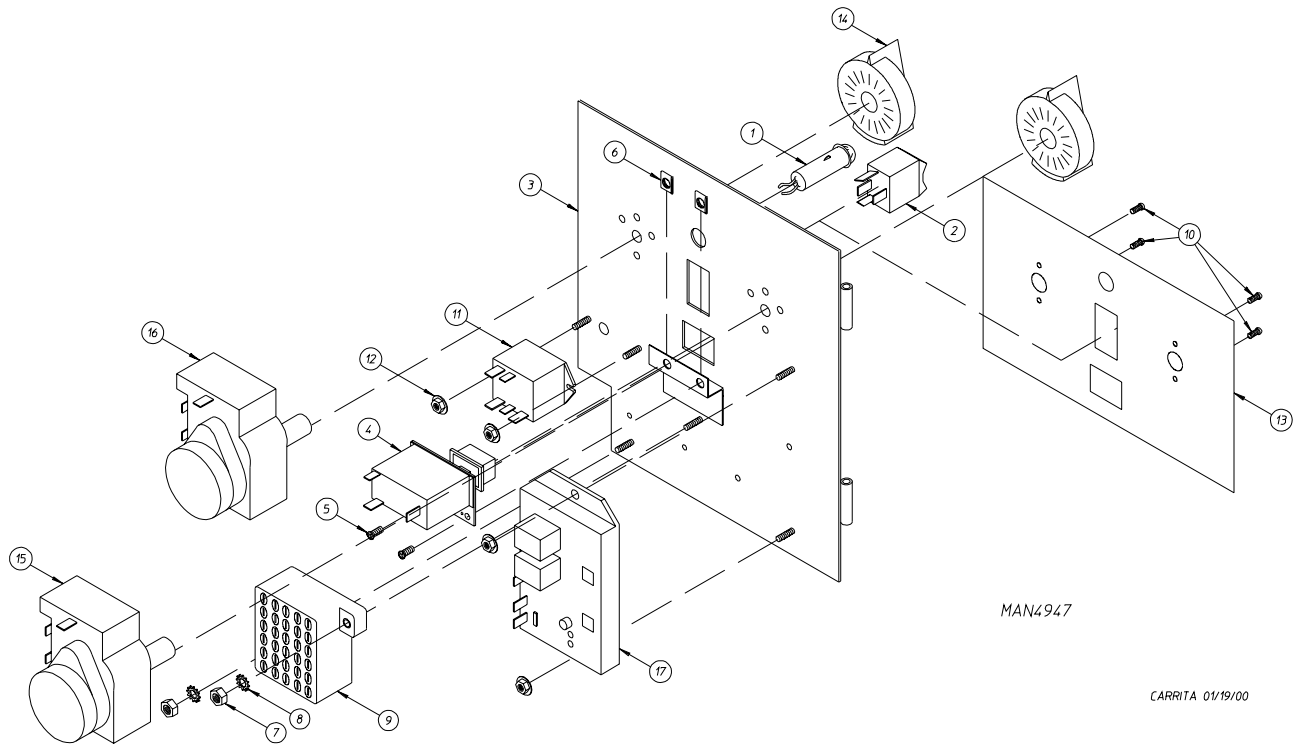

<u>Illus. No.</u>	<u>Part No.</u>	<u>Qty.</u>	<u>Description</u>
1	123005	1	Red Indicator Light - 24 VAC
2	122400	1	Rocker Heat Selector Switch
3	882596	1	Dual Timer Control Panel Assembly Complete - 24 VAC (includes illus. nos. 1 through 16)
	882600	1	Dual Timer Reversing Control Panel Assembly Complete - 24 VAC (includes illus. nos. 1 through 17)
	850456	1	Dual Timer Control Panel ONLY
4	131917	1	Push-To-Start Relay - 24 VAC
5	150207	2	#10-24 x 1/2" Phillips Pan Head Machine Screw
6	154001	2	#10-24 Speed Nut
7	152000	2	#6-32 Hex Nut
8	153010	2	#6 Star Washer
9	120730	1	30-Position Terminal Block
10	150110	4	#8-32 x 1/4" Phillips Round Head Machine Screw
11	131932	1	Dual Timer Relay - 24 VAC
12	151000	4	#6-32 Pal Nut
13	112050	1	Dual Timer Label ONLY
14	124103	2	Arrow Timer Knob
15	124025	1	60 Minute Timer - 24 VAC
16	124030	1	15 Minute Timer - 24 VAC
17	132198	1	Reversing Timer - 24 VAC
--	882540	1	Panel Wiring (non-reversing panel)...Not Illustrated
--	882573	1	Panel Wiring (reversing panel)...Not Illustrated

For Models Mfd. as of January 25, 2002

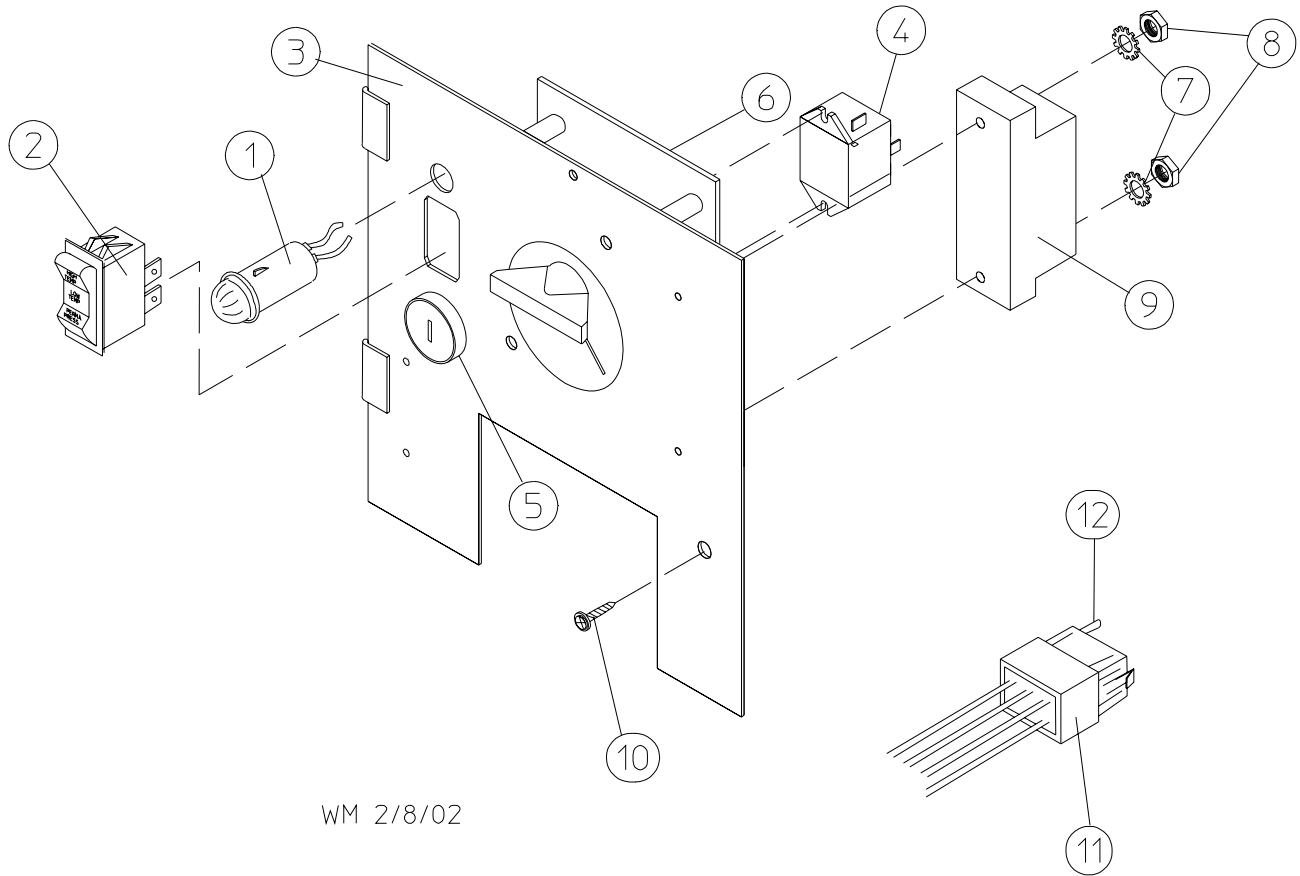

WM 2/8/02

MAN6086

<u>Illus. No.</u>	<u>Part No.</u>	<u>Qty.</u>	<u>Description</u>
1	123005	1	Red Indicator Light - 24 VAC
2	122400	1	Rocker Heat Selector Switch
3	824172	1	Coin Meter Control Panel Assembly Less Coin Meter (includes illus. nos. 2 through 5, 7, and 8)
	824109	1	Coin Meter Control Panel ONLY
4	131932	1	24 VAC Relay
	154001	2	#10-24 Speed Nut (used on P/N: 131932, 24 VAC relay)
5	123225	1	Green Push-To-Start Button
6	125601	1	25¢ Coin Meter - 24 VAC (specify timing)
7	153010	2	#6 Star Washer
8	152016	2	#4-40 Hex Nut
9	120712	1	12-Position Terminal Block
10	150300	1	#10-16 x 1/2" Hex Washer TEK Screw
11	122602	1	9-Pin Connector
12	122700	7	Pin Terminal ONLY
--	122801	1	Pin Extraction Tool

NOTE: For Coin Meter Replacement Parts refer to **page 56.**

For Models Mfd. prior to January 25, 2002

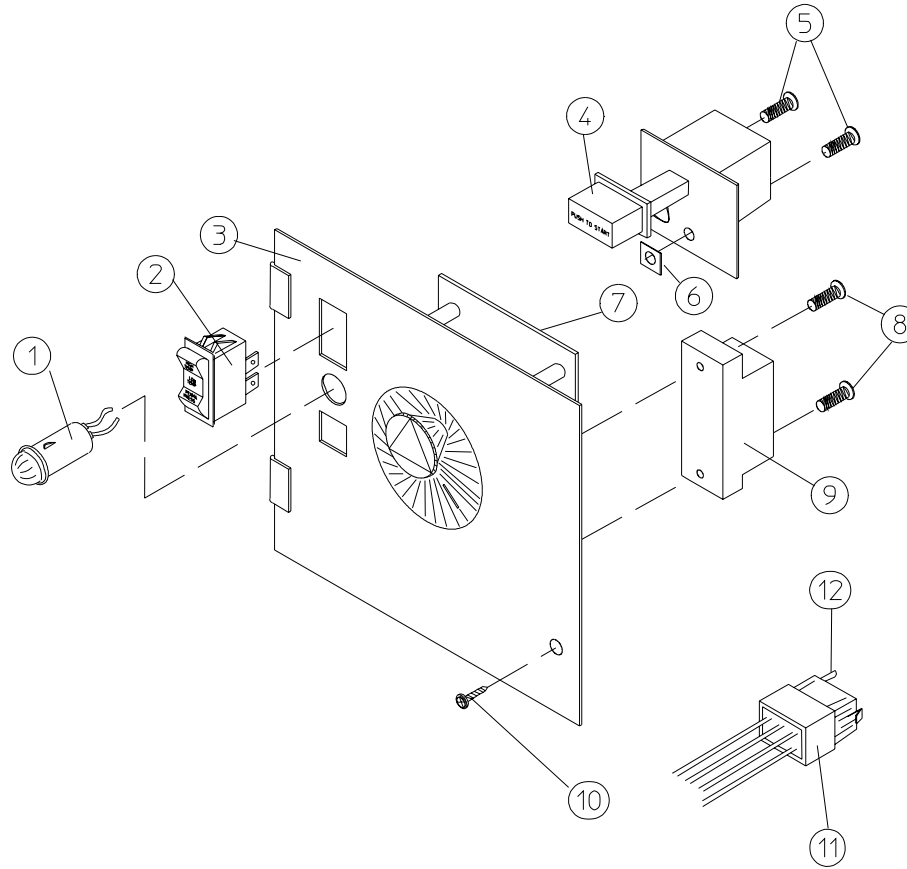

MAN1625

<u>Illus. No.</u>	<u>Part No.</u>	<u>Qty.</u>	<u>Description</u>
1	123005	1	Red Indicator Light - 24 VAC
2	122400	1	Rocker Heat Selector Switch
3	824020	1	Coin Meter Control Panel Assembly Complete - 24 VAC (includes illus. nos. 1 through 6, and 8 through 12)
	800054	1	Coin Meter Control Panel ONLY
4	131917	1	Push-To-Start Relay - 24 VAC
5	150207	2	#10-24 x 1/2" Round Head Machine Screw
6	154001	2	#10-24 Speed Nut
7*	125601	1	25¢ Coin Meter - 24 VAC (specify timing)
8	150303	2	#4 x 3/4" Pan Head "A" Screw
9	120712	1	12-Position Terminal Block
10	150309	1	#10-16 x 1/2" Hex Head TEK Crimpite Screw
11	122602	1	9-Pin Connector ONLY
12	122700	9	Pin Terminal ONLY
--	122801	1	Pin/Socket Extraction Tool

* Consult factory for coin meters not listed.

NOTE: For Coin Meter Replacement Parts refer to **page 56**.

For Models Mfd. with Steel Main Door as of July 1, 2002

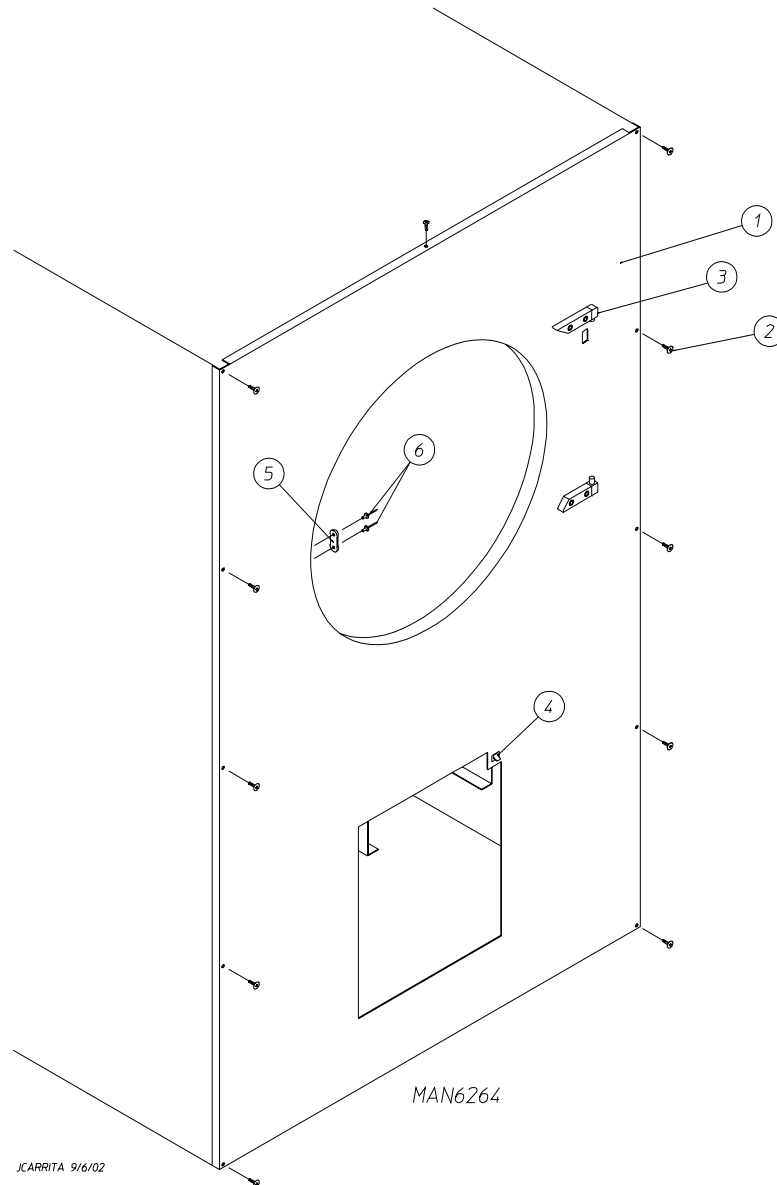

<u>Illus. No.</u>	<u>Part No.</u>	<u>Qty.</u>	<u>Description</u>
1	883567	1	White Front Panel Assembly (includes illus. nos. 1, 3, and 5 through 6)
	883568	1	Ivory Front Panel Assembly (includes illus. nos. 1, 3, and 5 through 6)
	883569	1	Coral Blue Front Panel Assembly (includes illus. nos. 1, 3, and 5 through 6)
2	150313	11	#10-16 x 1/2" TORX + BTN Type 1
	150318	1	25 IP TORX + Bit 1/4 Hex (for removal of TORX head screw)
3	-----	1	Main Door Hinge (refer to Main Door "Steel" Assembly on page 18)
4	122002	1	Lint Drawer Switch
5	170330	1	Friction Door Latch
6	154215	2	5/32" Pop Rivet

For Models Mfd. with Steel Main Door prior to July 1, 2002

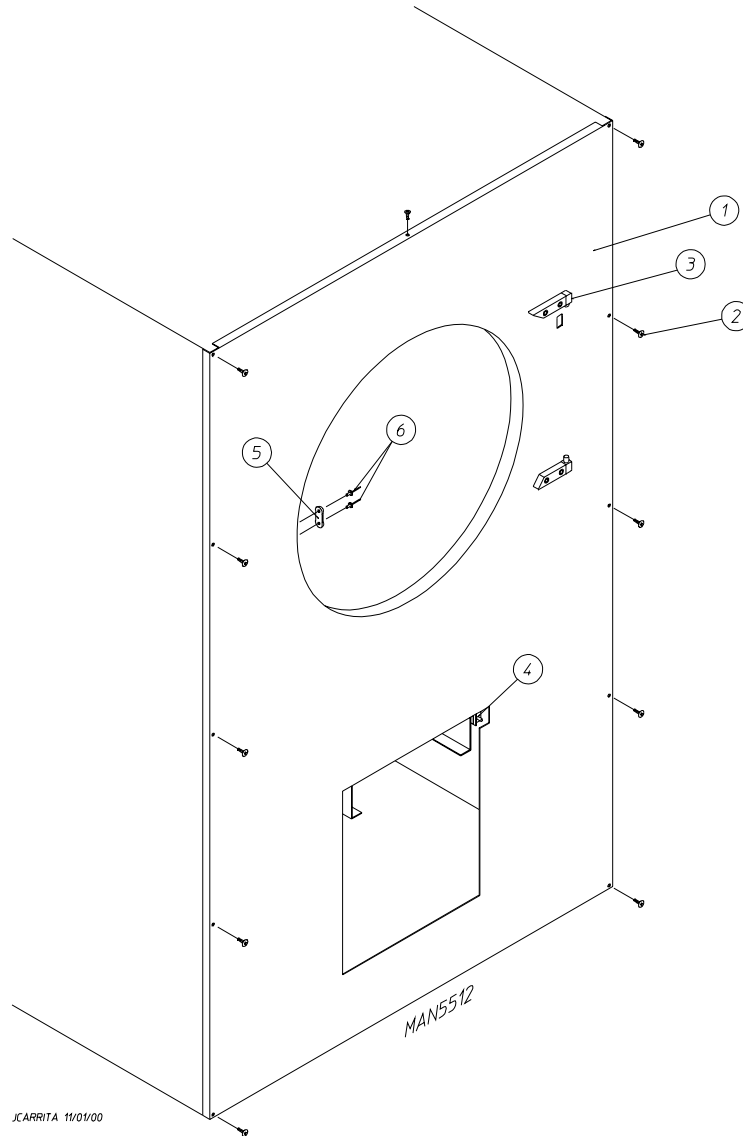

<u>Illus. No.</u>	<u>Part No.</u>	<u>Qty.</u>	<u>Description</u>
1	883137	1	White Front Panel Assembly (includes illus. nos. 1, 5, and 6)
	883138	1	Coral Blue Front Panel Assembly (includes illus. nos. 1, 5, and 6)
	883139	1	Ivory Front Panel Assembly (includes illus. nos. 1, 5, and 6)
2	150313	11	#10-16 x 1/2" TORX + BTN Type 1
	150318	1	25 IP TORX + Bit 1/4 Hex (for removal of TORX head screw)
3	-----	1	Main Door Hinge (refer to Main Door "Steel" Assembly on page 18)
4	-----	1	Lint Drawer Switch (refer to Lint Drawer/Lint Drawer Switch Assembly on page 25)
5	170330	1	Friction Door Latch
6	154215	2	5/32" Pop Rivet

For Models Mfd. with Plastic Main Door

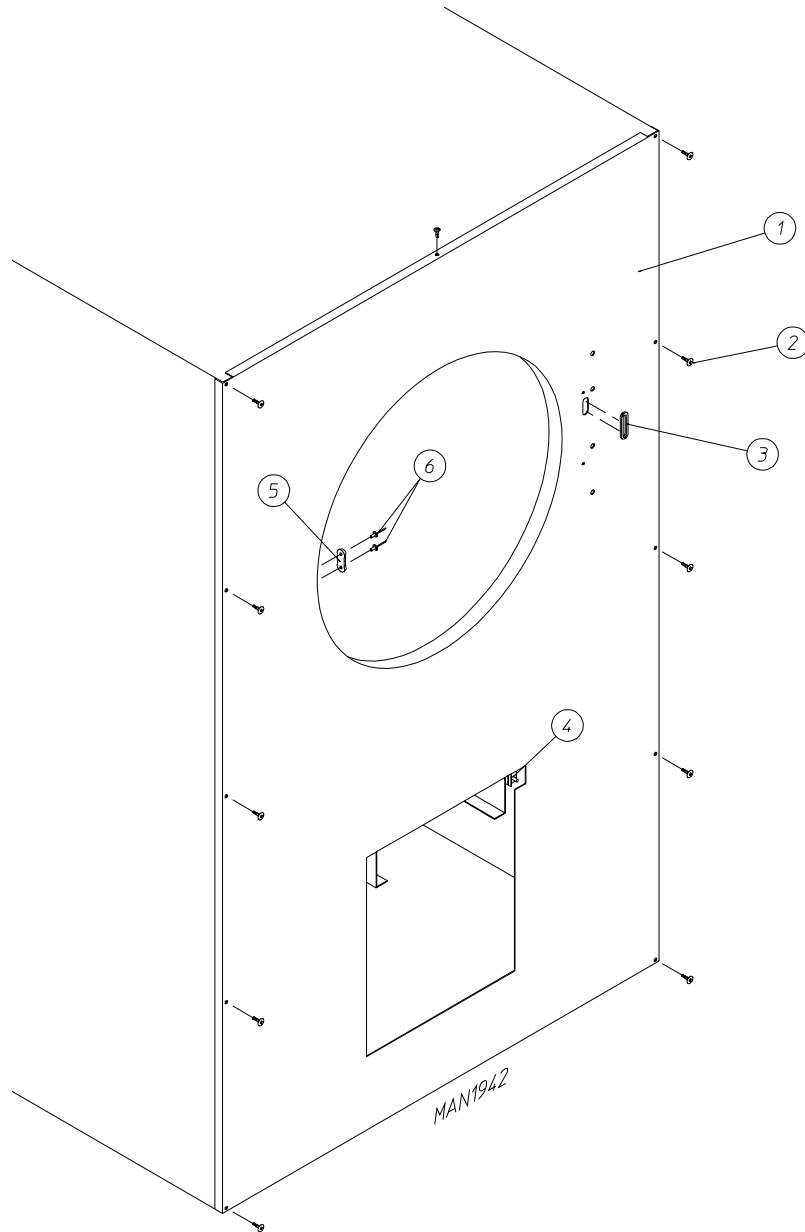

<u>Illus. No.</u>	<u>Part No.</u>	<u>Qty.</u>	<u>Description</u>
1	882529	1	White Front Panel Assembly (includes illus. nos. 1, 3, 5, and 6)
	882530	1	Almond B Front Panel Assembly (includes illus. nos. 1, 3, 5, and 6)
	882531	1	Coral Blue Front Panel Assembly (includes illus. nos. 1, 3, 5, and 6)
2	150309	11	#10-16 x 1/2" Hex Head TEK Crimptite Screw
3	121405	1	Rubber Grommet
4	-----	1	Lint Drawer Switch (refer to Lint Drawer/Lint Drawer Switch Assemblies on page 26)
5	170330	1	Friction Door Latch
6	154215	2	5/32" Pop Rivet

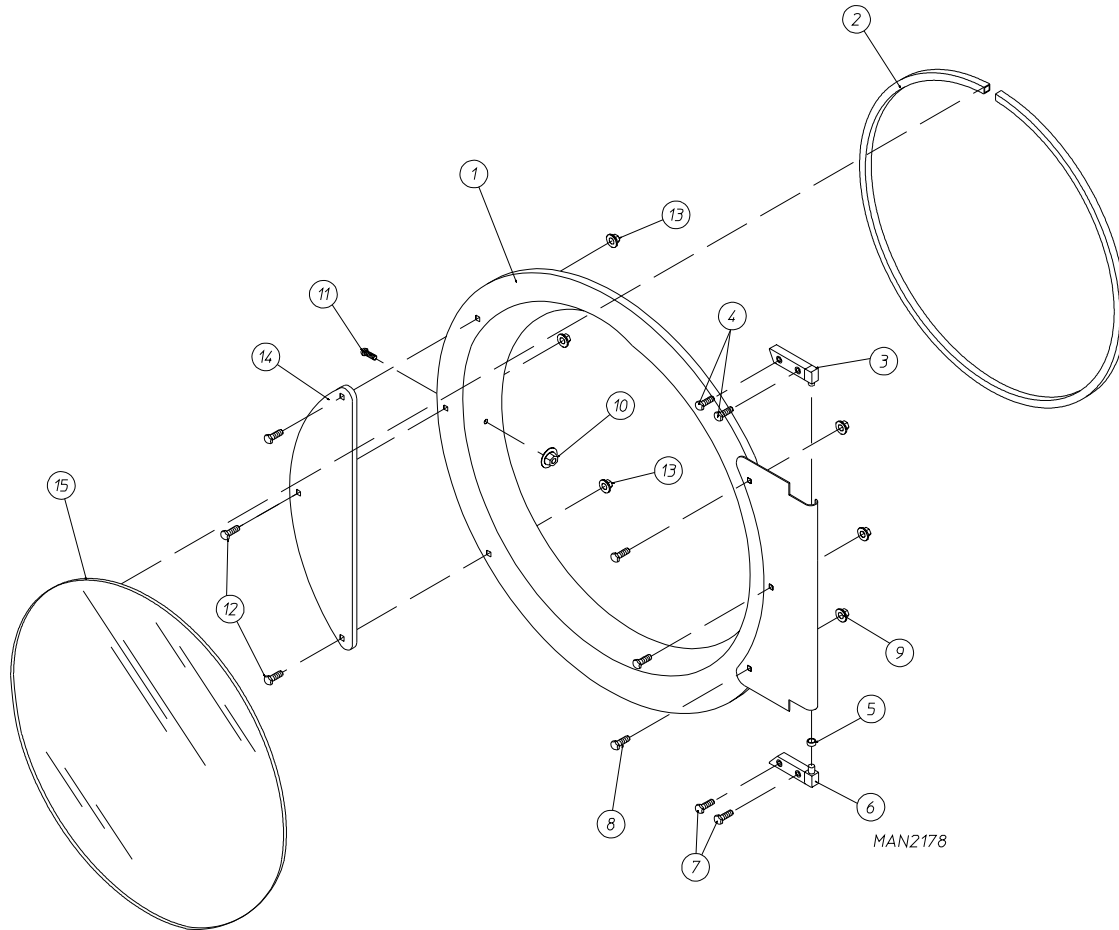

<u>Illus. No.</u>	<u>Part No.</u>	<u>Qty.</u>	<u>Description</u>
1	881150	1	Black Main Door Assembly Complete (includes illus. nos. 1, 2, and 8 through 15)
2	102354	1	Door Gasket
	170731	1	Black Gasket Adhesive (10.3 oz. cartridge)
3	881152	1	Black Top Hinge Block Assembly (includes illus. nos. 3 and 4)
4	150445	2	1/4-20 x 3/4" Black Cap Head Setscrew
5	153031	1	1/4" Nylon Washer
6	881151	1	Black Bottom Hinge Block Assembly (includes illus. nos. 5, 6, and 7)
7	150445	2	1/4-20 x 3/4" Black Cap Head Setscrew
8	150683	3	1/4-20 x 5/8" Black Carriage Bolt
9	152014	3	1/4-20 Free Spin Wash Nut
10	151010	1	#10-32 Black Hex Acorn Nut
11	150125	1	Door Latch Screw
12	150683	3	1/4-20 x 5/8" Black Carriage Bolt
13	152014	3	1/4-20 Free Spin Wash Nut
14	881210	1	Black Main Door Handle ONLY
15	102211	1	20-7/16" Door Glass
	170731	1	Black Glass Adhesive (10.3 oz. cartridge)

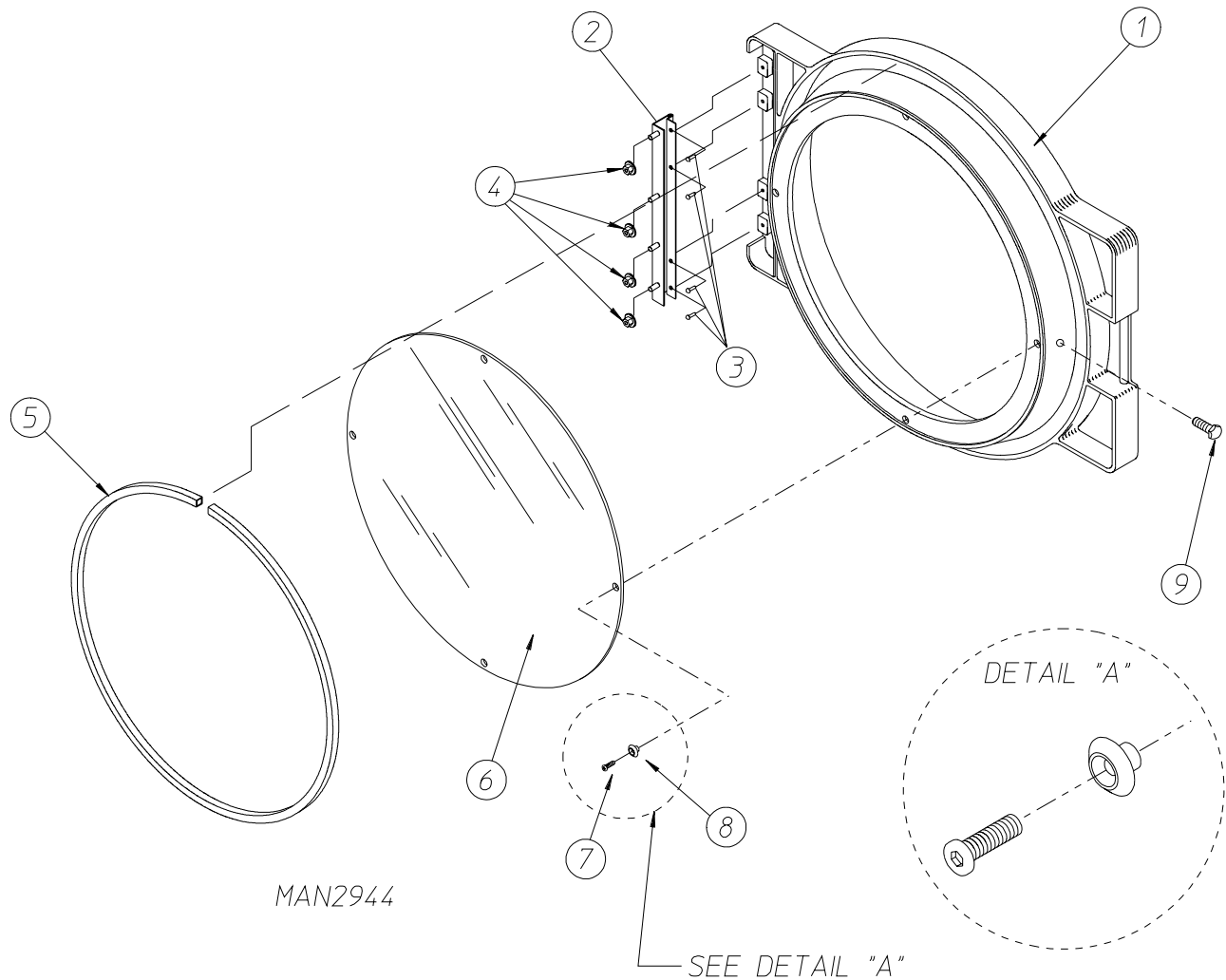

<u>Illus. No.</u>	<u>Part No.</u>	<u>Qty.</u>	<u>Description</u>
1	881422	1	Black Plastic Main Door Assembly Complete with Mechanical Fasteners (includes illus. nos. 1 and 5 through 9)
2	800448	1	12-1/2" Stainless Steel Main Door Hinge Assembly
3	150410	4	#10-24 x 3/8" Phillips Pan Head Taptite Screw
4	152014	4	1/4-20 Free Spin Wash Nut
5	102349	1	Main Door Gasket
	170730	1	Clear Gasket Adhesive (10.3 oz. cartridge)
6	102212	1	20-7/16" Door Glass with Four (4) Holes
	170730	1	Clear Glass Adhesive (10.3 oz. cartridge)
7	150448	4	1/2" Stainless Steel Flat Head Allen Screw
8	170319	4	Door Glass (nylon) Spacer
9	150431	1	Main Door Latch Screw (#10 x 7/16" dome hex head screw)

For Models Mfd. with Steel Main Door

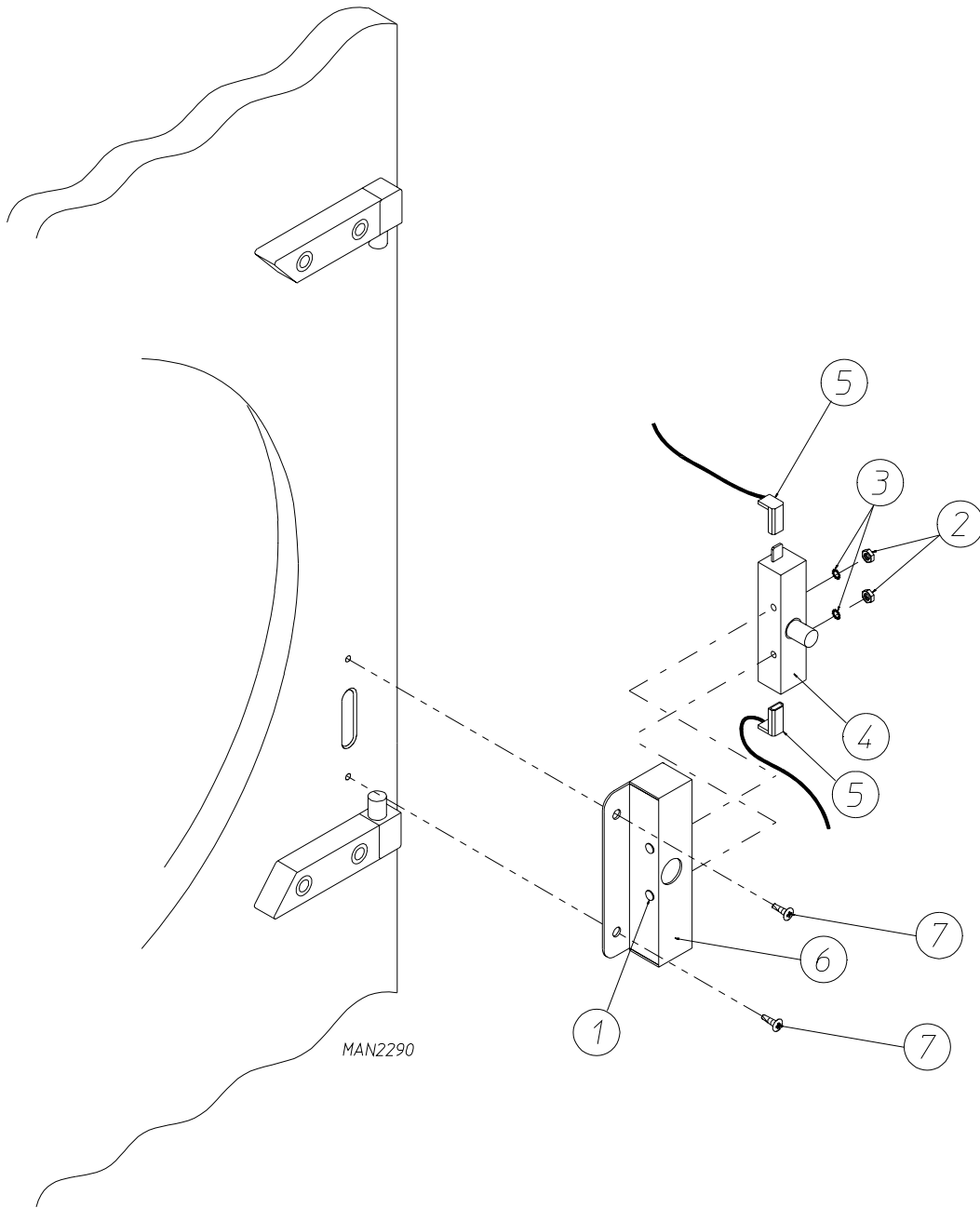

<u>Illus. No.</u>	<u>Part No.</u>	<u>Qty.</u>	<u>Description</u>
1	150006	2	#6-32 x 7/8" Phillips Pan Head Machine Screw
2	152013	2	#6-32 Hex Nut
3	153010	2	#6 Star Washer
4	137005	1	Door Switch
5	122636	2	Flag Terminal
6	881211	1	Black Main Door Switch Housing ONLY
	881153	1	Black Main Door Switch Housing Complete (includes illus. nos. 1 through 4 and 6)
7	150301	2	#8-18 x 7/16" Phillips Pan Head TEK Screw

For Models Mfd. with Plastic Main Door

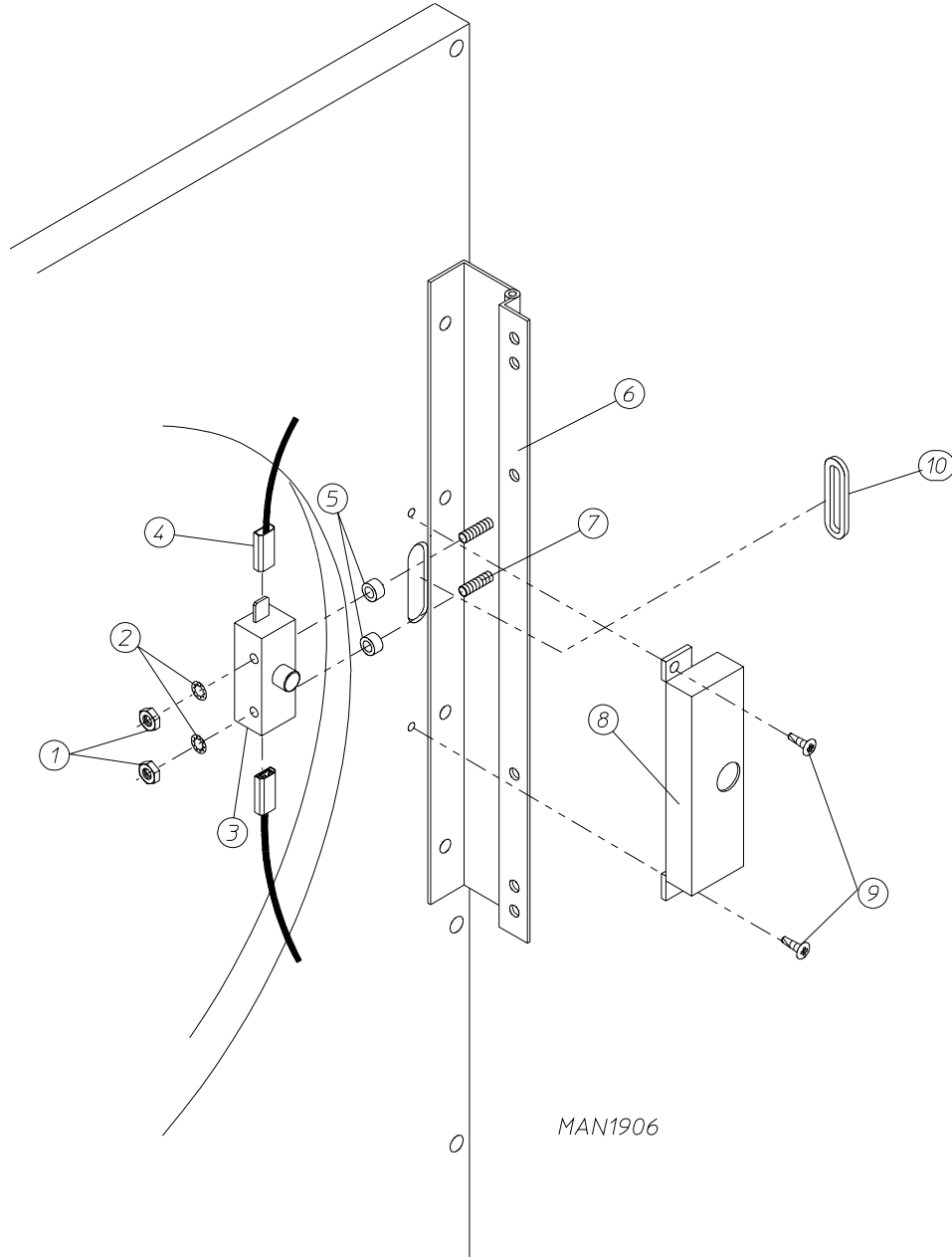

<u>Illus. No.</u>	<u>Part No.</u>	<u>Qty.</u>	<u>Description</u>
1	152013	2	#6-32 Hex Nut
2	153008	2	#6 Lock Washer
3	137005	1	Single Pole Door Switch
4	121028	2	Insulated Female Terminal
5	154281	2	3/8" Standard Nylon Spacer
6	800448	1	12-1/2" Stainless Steel Main Door Hinge Assembly (includes illus. nos. 6 and 7)
7	153565	2	#6-32 x 1" Self-Clinching Stud
8	881246	1	Main Door Switch Housing
9	150201	2	#10-32 x 1/4" Phillips Pan Head Screw
10	121405	1	Rubber Grommet

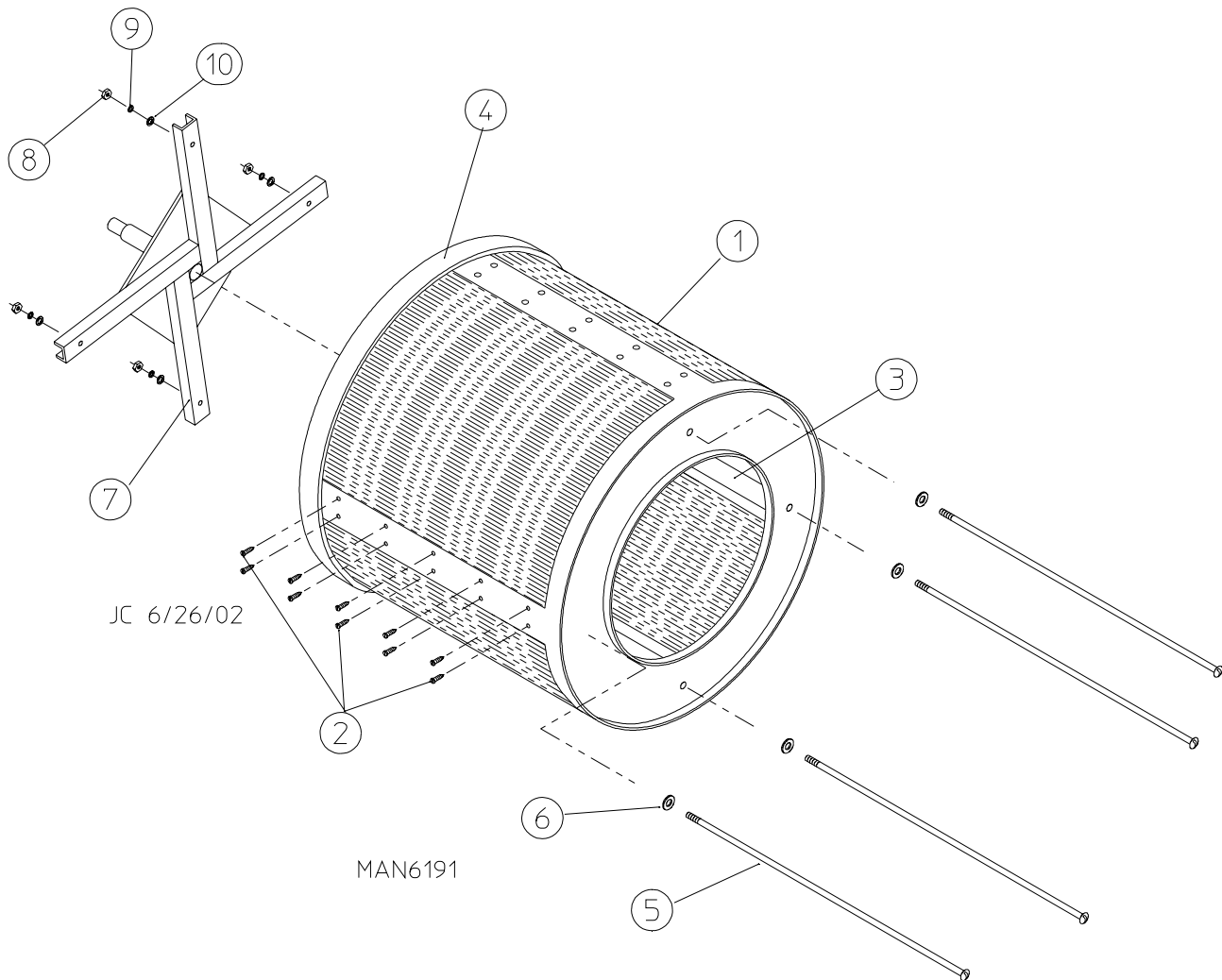

<u>Illus. No.</u>	<u>Part No.</u>	<u>Qty.</u>	<u>Description</u>
1*	800702	1	Galvanized Basket (tumbler) ONLY (without felt collar)
	817085	1	Galvanized Basket (tumbler)/Support Assemblies Complete (includes illus. nos. 1 through 10)
	800731	1	Stainless Steel Basket (tumbler) ONLY (without felt collar)
	800752	1	Stainless Steel Basket (tumbler)/Support Assemblies Complete (includes illus. nos. 1 through 10)
2	150413	24	#10-16 x 1/2" TORX Crimptite
3	301305	4	Galvanized Basket (tumbler) Rib ONLY
	301420	4	Stainless Steel Basket (tumbler) Rib ONLY
4	116002	1	Felt Collar ONLY
5	100901	4	5/16-18 x 20" Tie Rod
6	153001	4	5/16" Flat Washer
7	817084	1	Basket (tumbler) Support ONLY
8	152004	4	5/16-18 Hex Nut
9	153002	4	5/16" Lock Washer
10	153001	4	5/16" Flat Washer
--	401010	1	#847 Adhesive for Felt Collar (5.0 oz. tube)

* Felt collar is not included and **must be** ordered separately.

For Models Mfd. as of July 1, 2002

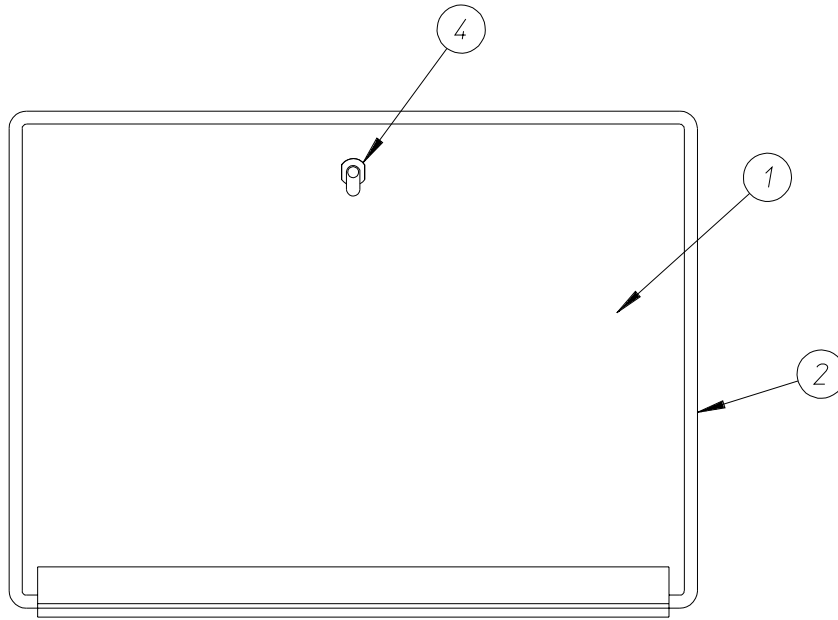

JC 8/26/02

MAN6250

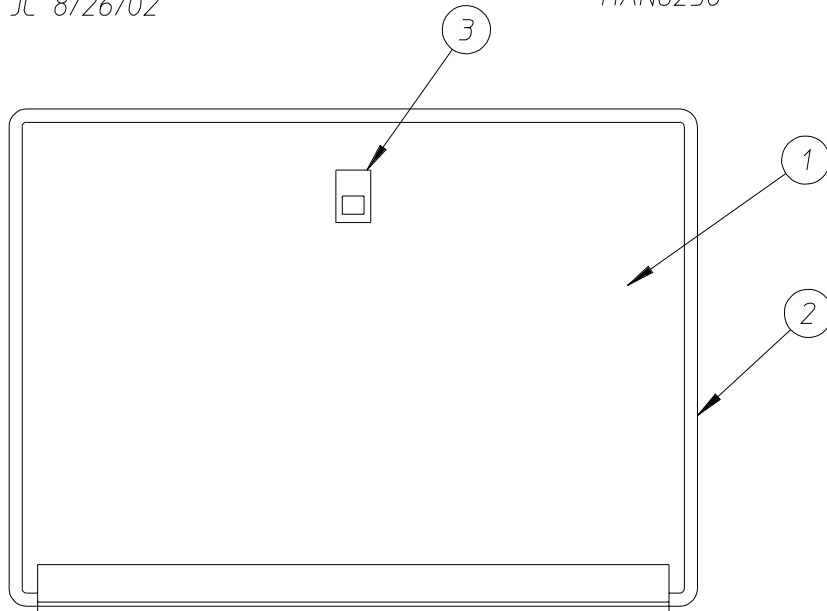

<u>Illus. No.</u>	<u>Part No.</u>	<u>Qty.</u>	<u>Description</u>
1	802277	1	Drop Lint Door (for OPL models) (includes illus. nos. 1 through 3)
	802265	1	Drop Lint Door (for coin models) (includes illus. nos. 1, 2, and 4)
2	117604	5	Sponge Tape (sold by the foot)
3	170226	1	Slide Latch (for OPL models)
4	160001	1	Lint Door AD-100 Lock (for coin models)
	160103	1	Key ONLY

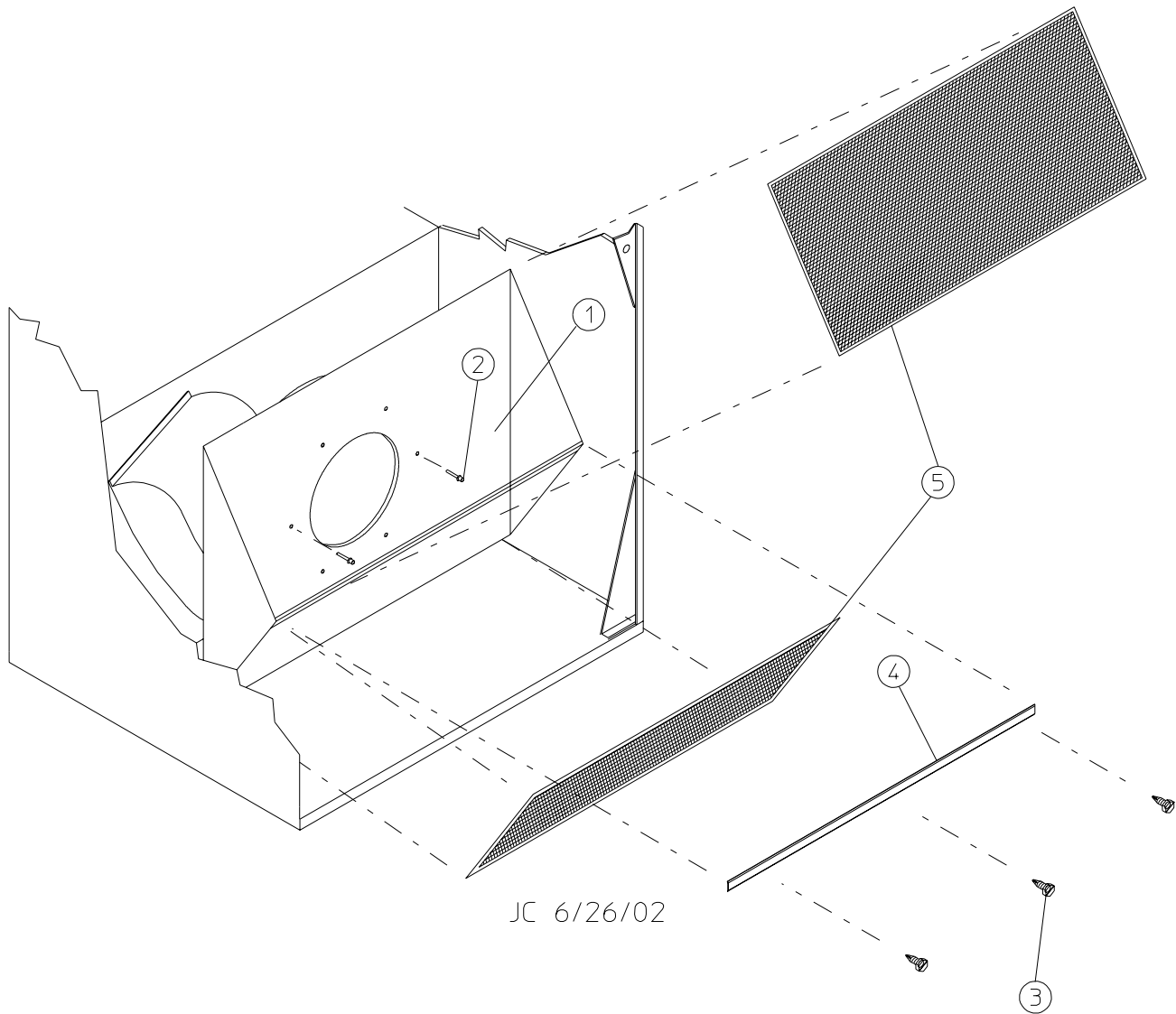

MAN6192

<u>Illus. No.</u>	<u>Part No.</u>	<u>Qty.</u>	<u>Description</u>
1	800401	1	Lint Trap Assembly Complete (includes illus. nos. 1 and 3 through 5)
	800443	1	Lint Trap ONLY
2	154200	6	5/32" Pop Rivet
3	150300	3	#10-16 x 1/2" Hex Washer TEK Screw
4	304100	1	Lint Screen Holder ONLY
5	800500	2	Lint Screen Assembly

For Models Mfd. between July 25, 2000 and July 1, 2002

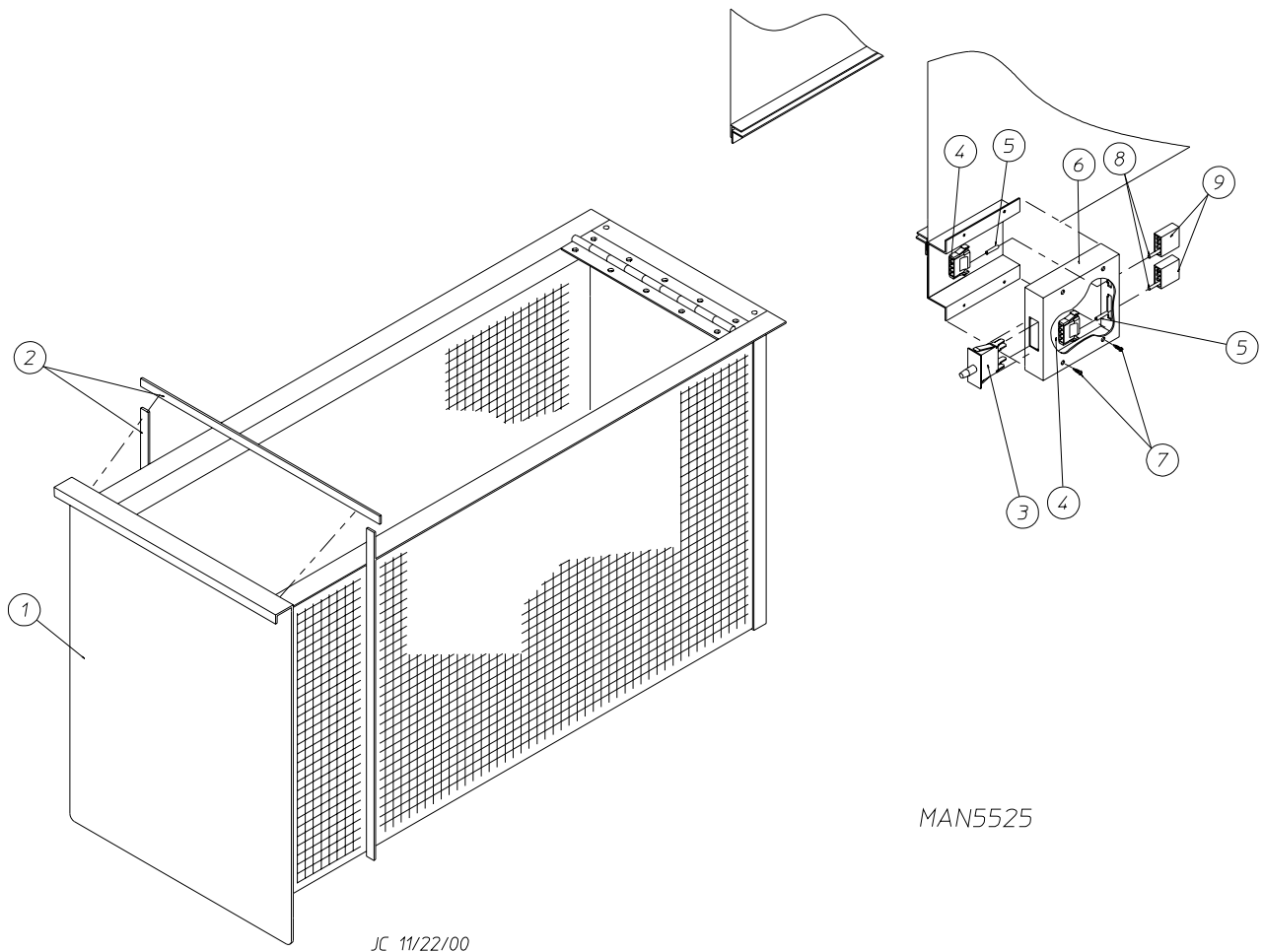

MAN5525

JC 11/22/00

<u>Illus. No.</u>	<u>Part No.</u>	<u>Qty.</u>	<u>Description</u>
1	883140	1	White Lint Drawer Assembly (includes illus. nos. 1 and 2)
	883136	1	Coral Blue Lint Drawer Assembly (includes illus. nos. 1 and 2)
	883135	1	Ivory Lint Drawer Assembly (includes illus. nos. 1 and 2)
2	117605	5	Gasket (sold by the foot)
3	122116	1	Lint Drawer Switch
4	122605	2	4-Pin Socket Connector ONLY
5	122701	4	Socket Terminal ONLY
	122801	1	Pin/Socket Extraction Tool
6	818087	1	Lint Drawer Switch Box Assembly (includes illus. nos. 3 through 6)
	304136	1	Lint Drawer Switch Box Cover ONLY
7	150301	2	#8-18 x 7/16" Phillips Pan Head TEK Screw
8	122700	4	Pin Terminal ONLY
9	122604	2	4-Pin Connector ONLY

For Models Mfd. prior to July 25, 2000

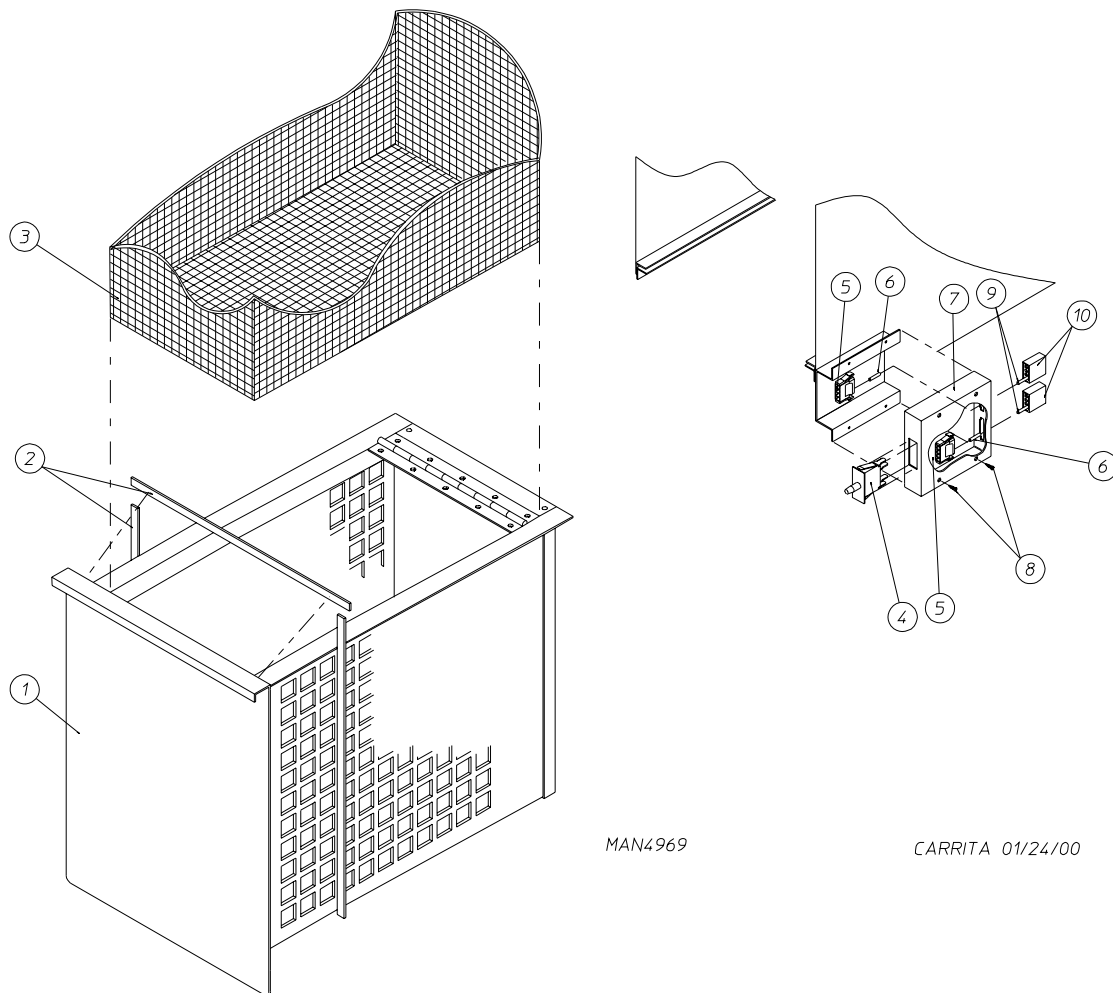

MAN4969

CARRITA 01/24/00

<u>Illus. No.</u>	<u>Part No.</u>	<u>Qty.</u>	<u>Description</u>
1	882616	1	White Lint Drawer Assembly (includes illus. nos. 1 and 2)
	882614	1	Almond B Lint Drawer Assembly (includes illus. nos. 1 and 2)
	882615	1	Coral Blue Lint Drawer Assembly (includes illus. nos. 1 and 2)
2	117605	5	Noise Suppressor Tape (sold by the foot)
3	108223	1	Lint Screen Assembly
4	122116	1	Lint Drawer Switch
5	122605	2	4-Pin Socket Connector
6	122701	4	Socket Terminal ONLY
	122801	1	Pin/Socket Extraction Tool
7	800478	1	Lint Drawer Switch Box Assembly (includes illus. nos. 4 through 7)
	304136	1	Lint Drawer Switch Box ONLY
8	150301	2	#8-18 x 7/16" Phillips Pan Head TEK Screw
9	122700	4	Pin Terminal ONLY
10	122604	2	4-Pin Connector ONLY

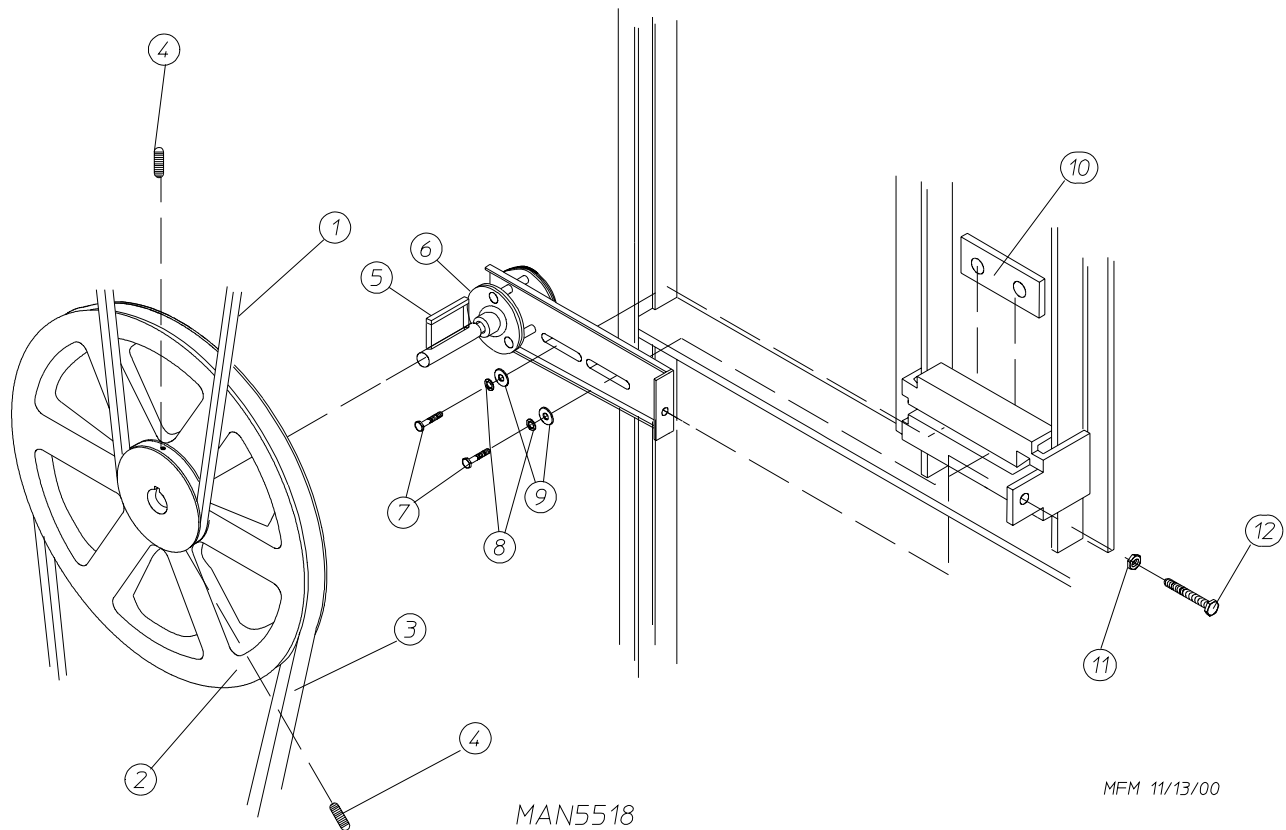

<u>Illus. No.</u>	<u>Part No.</u>	<u>Qty.</u>	<u>Description</u>
1	100107	1	5L-670 V-Belt (basket [tumbler] to idler) (for non-reversing models Only)
	100108	1	5L-680 V-Belt (basket [tumbler] to idler) (for reversing models Only)
2	101129	1	9" x 2-1/2" Compound Pulley
3	100103	1	4L-510 V-Belt (for non-reversing models Only)
	100112	1	4L-610 V-Belt (idler to motor) (for reversing models Only)
4	154301	2	5/16-18 x 1" Allen Setscrew
5	100705	1	3/16" x 3/16" x 1-3/8" Key
6	882576	1	Idler Bearing Assembly Complete (includes illus. nos. 5 through 12)
7	150617	2	3/8-16 x 1" Hex Head Machine Bolt
8	153005	2	3/8" Lock Washer
9	153004	2	3/8" Flat Washer
10	801009	1	Idler Square Washer
11	152004	1	5/16-18 Hex Nut
12	150509	1	5/16-18 x 3" Hex Head Machine Bolt

MAN0267

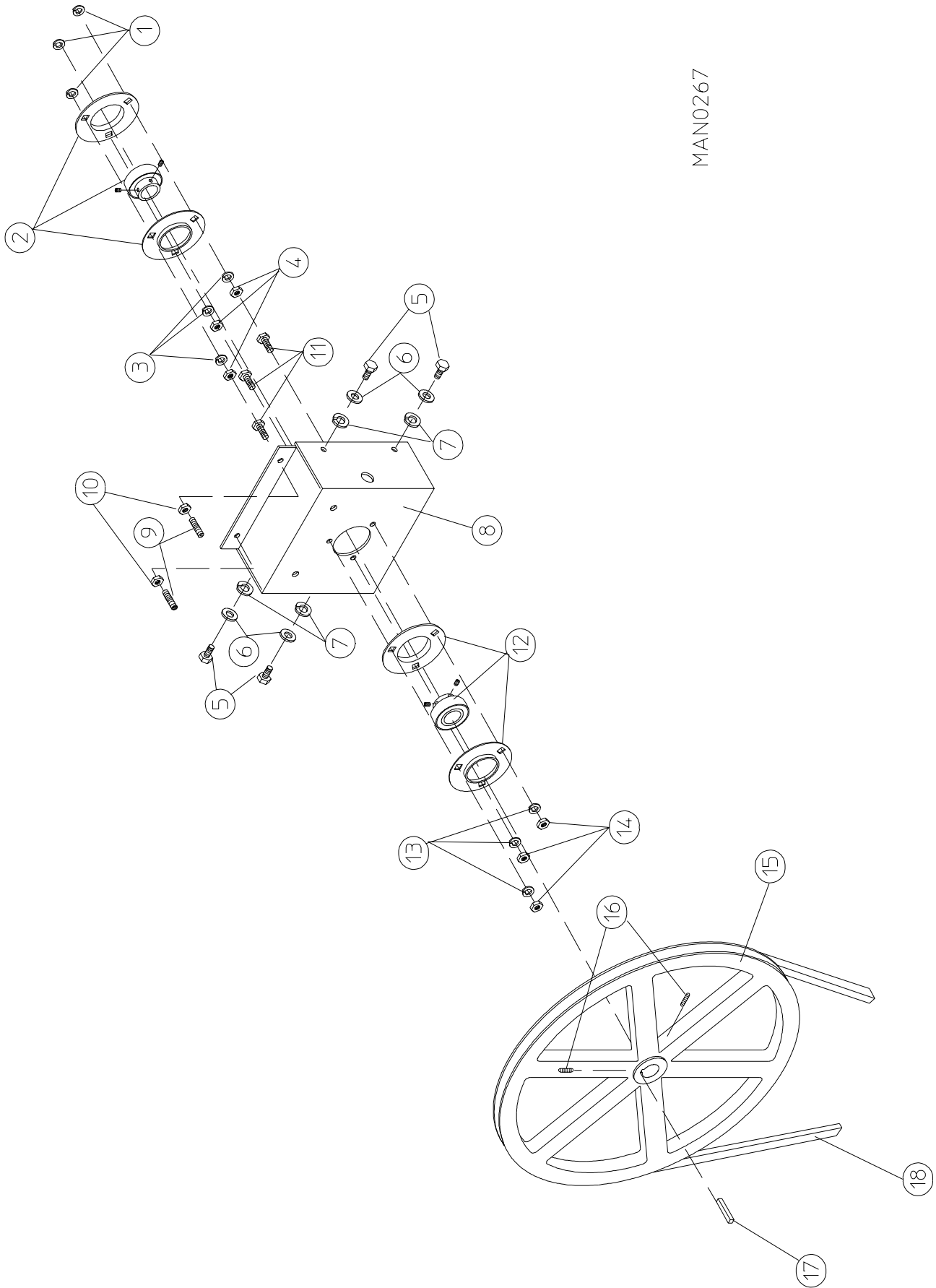

<u>Illus. No.</u>	<u>Part No.</u>	<u>Qty.</u>	<u>Description</u>
1	153002	3	5/16" Lock Washer
2	880213	1	1-1/4" Flange Bearing with Nylock Setscrew
3	153002	3	5/16" Lock Washer
4	152004	3	5/16-18 Hex Nut
5	150501	4	5/16-18 x 3/4" Hex Head Machine Bolt
6	153002	4	5/16" Lock Washer
7	153004	4	3/8" Flat Washer
8	801100	1	1" Bearing Box Assembly Complete (includes illus. nos. 8 through 14)
	801105	1	Bearing Box ONLY
9	150608	2	5/16-18 x 1-1/4" Allen Setscrew
10	152004	2	5/16-18 Hex Nut
11	150501	3	5/16-18 x 3/4" Hex Head Machine Bolt
12	880201	1	1" Flange Bearing with Nylock Setscrew
13	153002	3	5/16" Lock Washer
14	152004	3	5/16-18 Hex Nut
15	101100	1	18" Pulley ONLY
	101118	1	18-3/4" Pulley (for reversing models Only)
	101110	1	1" Taper Lock Hub (for reversing models Only)
16	154301	2	5/16-18 x 5/16" Setscrew
17	100713	1	1/4" x 1/4" x 7/8" Key
18	100107	1	5L-670 V-Belt (basket [tumbler] to idler) (for non-reversing models Only)
	100108	1	5L-680 V-Belt (basket [tumbler] to idler) (for reversing models Only)

<u>Illus. No.</u>	<u>Part No.</u>	<u>Qty.</u>	<u>Description</u>
8	122701	8	Socket Terminal ONLY
	122801	1	Pin/Socket Extraction Tool
9	137030	1	8-Pin Housing Connector
10	152004	4	5/16-18 Hex Nut
11	153002	4	5/16" Lock Washer
12	153001	4	5/16" Flat Washer
13	117604	4	Sponge Tape (sold by the foot)
14	154000	4	5/16-18 Tinnerman Nut
15	850017	1	1/2 HP Motor Mount ONLY (56Z frame)
	817075	1	1/2 HP 115-230v 1 ϕ 60 Hz Totally Enclosed, Fan-Cooled (T.E.F.C.) Motor Mount Assembly Complete with Plug Motor (includes illus. nos. 2 through 7 and 13 through 20)
	817076	1	1/2 HP 240v 1 ϕ 50 Hz Motor Mount Assembly Complete with Plug Motor (includes illus. nos. 2 through 7 and 13 through 20)
	817080*	1	1/2 HP 208/230/380/460v 3 ϕ 60 Hz Totally Enclosed, Fan-Cooled (T.E.F.C.) Motor Mount Assembly Complete (includes illus. nos. 2 through 6 and 13 through 22)
	883271*	1	1/2 HP 208/230/380/460v 3 ϕ 50 Hz Totally Enclosed, Fan-Cooled (T.E.F.C.) Motor Mount Assembly Complete (includes illus. nos. 2 through 6 and 13 through 22)
16	153050	2	1/2" S.A.E. Flat Washer
17	100604	1	12-1/2" Impellor with 1/2" Bore
18	100702	1	1/8" x 1/8" x 1-1/2" Key
19	153050	2	1/2" S.A.E. Flat Washer
20	152006	2	1/2-20 Left Hand Jam Nut
21	120200	1	3/8" 90° Connector
22*	100007	1	1/2 HP 208/230/380/460v 3 ϕ 50/60 Hz Totally Enclosed, Fan-Cooled (T.E.F.C.) Motor (56Z frame)

* Specify voltage when ordering.

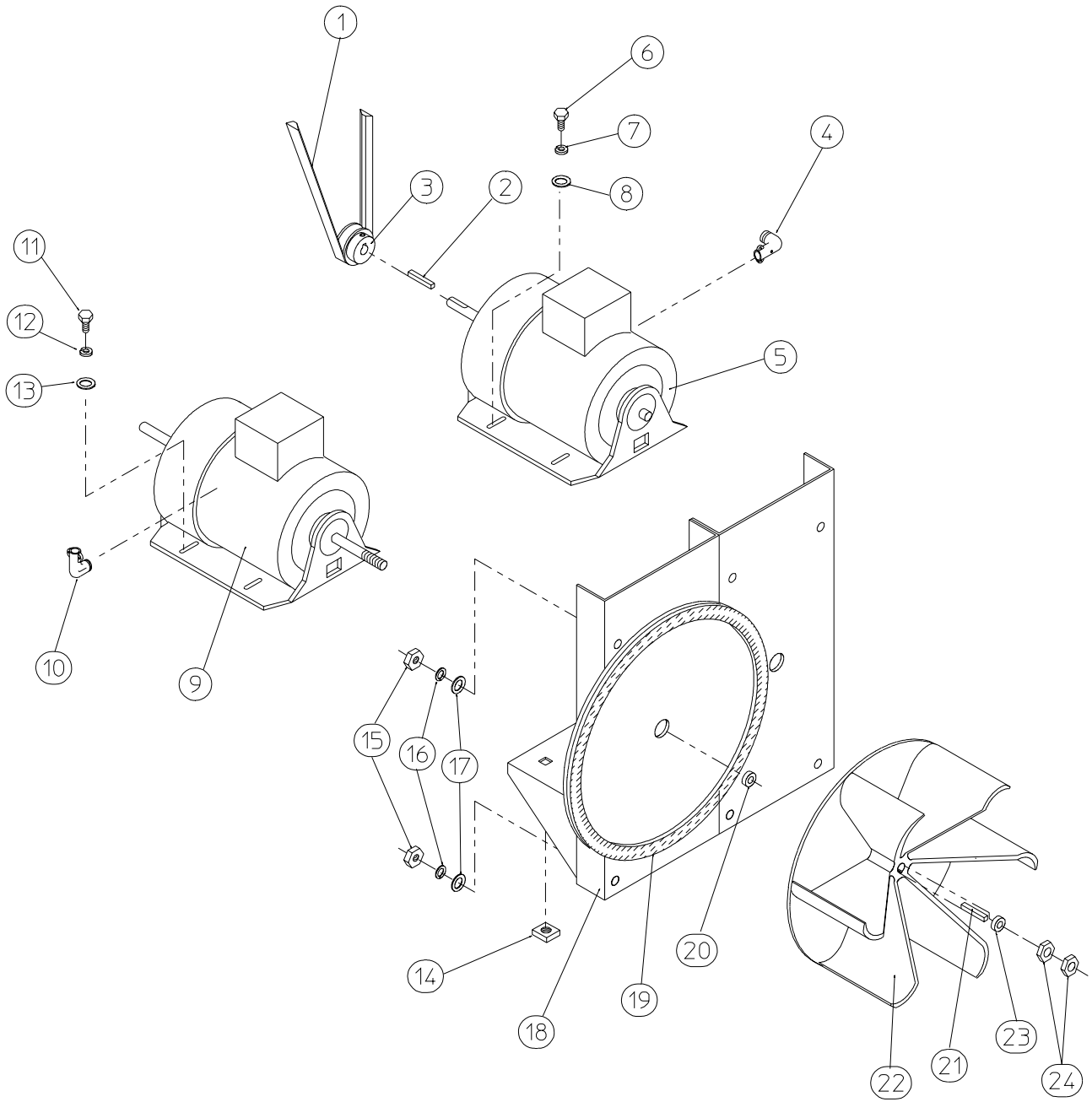

MAN1970

<u>Illus. No.</u>	<u>Part No.</u>	<u>Qty.</u>	<u>Description</u>
1	100112	1	4L-610 V-Belt (motor to idler)
2	100701	1	3/16" x 3/16" x 1" Key
3	101132	1	5/8" x 2" Motor Pulley (for 60 Hz models Only)
	101133	1	5/8" x 2-1/4" Motor Pulley (for 50 Hz models Only)
4	120200	1	3/8" x 90° Connector
5	181003	1	1/2 HP 208/230/380/460v 3ø 50/60 Hz Motor (56Z frame)
6	150501	4	5/16-18 x 3/4" Hex Head Machine Bolt
7	153002	4	5/16" Lock Washer
8	153001	4	5/16" Flat Washer
9	100007	1	1/2 HP 208/230/380/460v 3ø 50/60 Hz Totally Enclosed, Fan-Cooled (T.E.F.C.) Motor (56Z frame)
10	120200	1	3/8" x 90° Connector
11	150501	4	5/16-18 x 3/4" Hex Head Machine Bolt
12	153002	4	5/16" Lock Washer
13	153001	4	5/16" Flat Washer
14	154000	8	5/16" Tinnerman Nut
15	152004	4	5/16" Hex Nut
16	153002	4	5/16" Lock Washer
17	153001	4	5/16" Flat Washer
18	850070	1	Reversing Motor Mount ONLY (56Z frame) (includes illus. nos. 18 and 19)
	803802*	1	Reversing Totally Enclosed, Fan-Cooled (T.E.F.C.) Motor Mount Assembly Complete (for 60 Hz models Only) (includes illus. nos. 2 through 14 and 18 through 24)
	803803*	1	Reversing Totally Enclosed, Fan-Cooled (T.E.F.C.) Motor Mount Assembly Complete (for 50 Hz models Only) (includes illus. nos. 2 through 14 and 18 through 24)
19	117604	4	Sponge Tape (sold by the foot)
20	153050	2	1/2" S.A.E. Flat Washer
21	100702	1	1/8" x 1/8" x 1-1/2" Key
22	100604	1	12-1/2" Impellor with 1/2" Bore
23	153050	2	1/2" S.A.E. Flat Washer
24	152006	2	1/2-20 Left Hand Jam Nut

* Specify voltage when ordering.

For Models Mfd. as of July 1, 2002

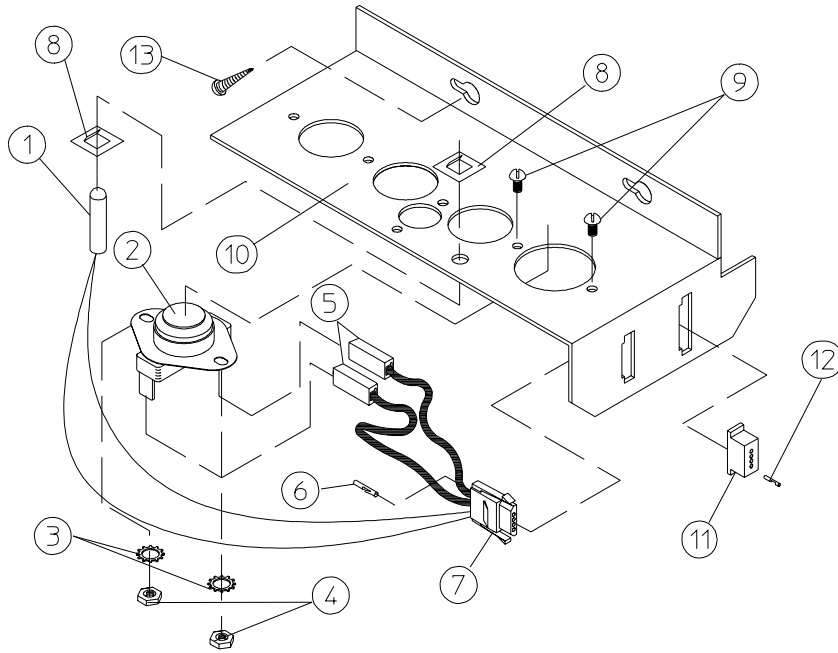

MICROPROCESSOR SENSOR BRACKET ASSEMBLY

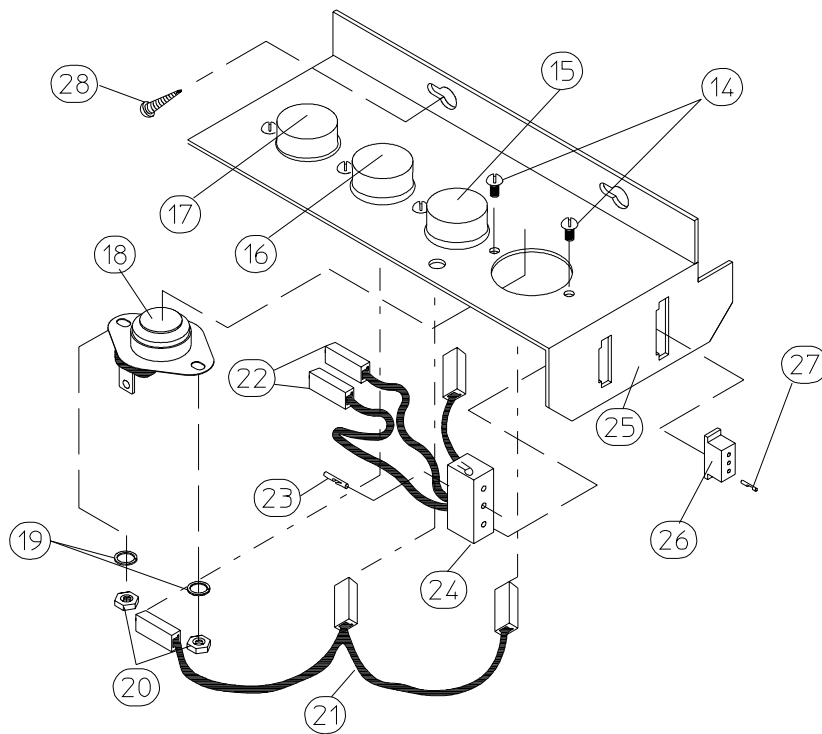

MAN0238

NON-COMPUTER SENSOR BRACKET ASSEMBLY

For Models Mfd. as of July 1, 2002

<u>Illus. No.</u>	<u>Part No.</u>	<u>Qty.</u>	<u>Description</u>
1	880251	1	1/4" Temperature Sensor Probe Assembly (includes illus. nos. 1 and 5 through 8)
2	130301	1	225° Large Manual Reset Thermostat
3	153010	2	#6 Star Washer
4	152000	2	#6-32 Hex Nut
5	121028	2	Insulated Terminal ONLY
6	122701	4	Socket Terminal ONLY
7	122605	1	4-Pin Socket Connector ONLY
8	154007	2	1/4" Tinnerman Push On Fastener
9	150005	2	#6-32 x 1/4" Phillips Round Head Machine Screw
10	801424	1	Microprocessor Sensor Bracket Assembly Complete (includes illus. nos. 1 through 10)
	305007	1	Universal Sensor Bracket ONLY
11	122604	1	4-Pin Connector ONLY
12	122700	4	Pin Terminal ONLY
13	150301	2	#8-18 x 7/16" Phillips Pan Head TEK Screw
14	150005	5	#6-32 x 1/4" Phillips Round Head Machine Screw
15	130111	1	130° Large Thermostat
16	130100	1	150° Large Thermostat
17	130103	1	225° Large Manual Reset Thermostat
18	130101	1	180° Large Thermostat
19	153010	5	#6 Star Washer
20	152000	5	#6-32 Hex Nut
21	840065	1	Sensor Jumper
22	121028	8	Insulated Terminal ONLY
23	122701	4	Socket Terminal ONLY
24	122605	1	4-Pin Socket Connector ONLY
	818007	1	Sensor Bracket Harness Assembly (includes illus. nos. 21 through 24)
25	818321	1	Noncomputer Sensor Bracket Assembly Complete - Includes Thermostats (includes illus. nos. 14 through 25)
	305007	1	Universal Sensor Bracket ONLY
26	122604	1	4-Pin Connector ONLY
27	122700	4	Pin Terminal ONLY
	122801	1	Pin/Socket Extraction Tool
28	150301	2	#8-18 x 7/16" Phillips Pan Head TEK Screw

For Models Mfd. prior to July 1, 2002

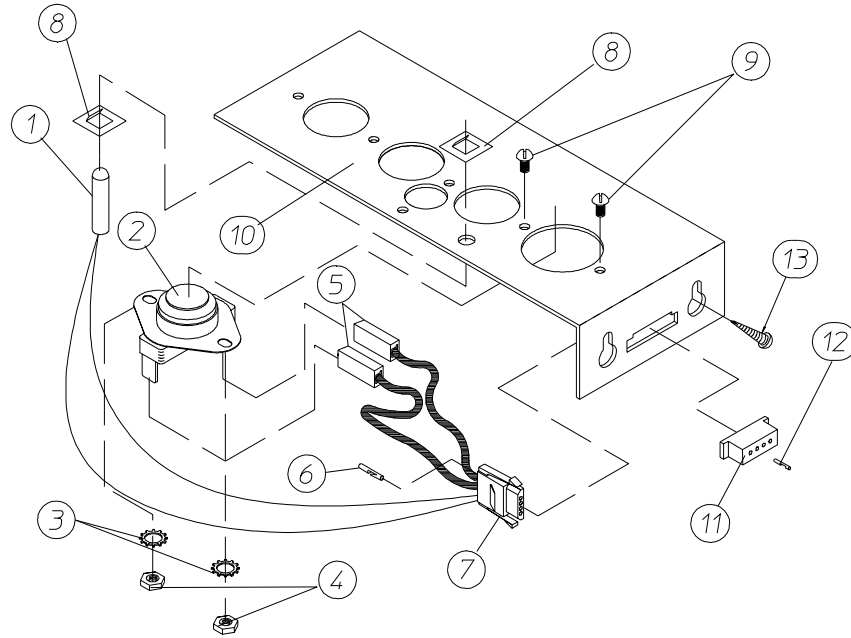

MICROPROCESSOR SENSOR BRACKET ASSEMBLY

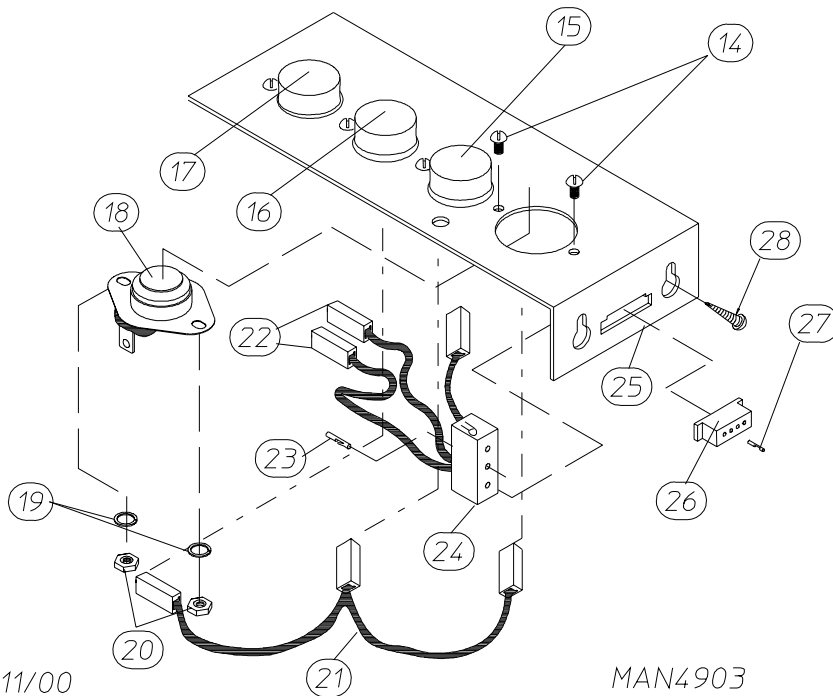

DX 01/11/00

MAN4903

NON-COMPUTER SENSOR BRACKET ASSEMBLY

For Models Mfd. prior to July 1, 2002

<u>Illus. No.</u>	<u>Part No.</u>	<u>Qty.</u>	<u>Description</u>
1	882533	1	1/4" Temperature Sensor Probe Assembly (includes illus. nos. 1 and 5 through 7)
2	130301	1	225° Manual Reset Thermostat
3	153010	2	#6 Star Washer
4	152000	2	#6-32 Hex Nut
5	121028	2	Insulated Terminal ONLY
6	122701	4	Socket Terminal ONLY
7	122605	1	4-Pin Socket Connector ONLY
8	154007	2	1/4" Tinnerman Push On Fastener
9	150005	2	#6-32 x 1/4" Round Head Machine Screw
10	817046	1	Microprocessor Sensor Bracket Assemblies Complete (for models mfd. prior to May 2, 2000) (includes illus. nos. 1 through 10)
	818084	1	Microprocessor Sensor Bracket Assemblies Complete (for models mfd. between May 2, 2000 and July 1, 2002) (includes illus. nos. 1 through 10)
	322062	1	Universal Sensor Bracket ONLY (for models mfd. prior to May 2, 2000)
	322080	1	Universal Sensor Bracket ONLY (for models mfd. between May 2, 2000 and July 1, 2002)
11	122604	1	4-Pin Connector ONLY
12	122700	4	Pin Terminal ONLY
13	150301	2	#8-18 x 7/16" Phillips Pan Head TEK Screw
14	150005	5	#6-32 x 1/4" Slotted Round Head Machine Screw
15	130111	1	130° Thermostat
16	130100	1	150° Thermostat
17	130301	1	225° Manual Reset Thermostat
18	130101	1	180° Thermostat
19	153010	5	#6 Star Washer
20	152000	5	#6-32 Hex Nut
21	882535	1	Sensor Jumper
22	121028	4	Insulated Terminal ONLY
23	122701	4	Socket Terminal ONLY
	122801	1	Pin/Socket Extraction Tool
24	122605	1	4-Pin Socket Connector ONLY
	882534	1	Sensor Bracket Harness Assembly (includes illus. nos. 22 through 24)
25	818083	1	Noncomputer Sensor Bracket Assembly Complete - Includes Thermostats (for models mfd. between May 2, 2000 and July 1, 2002) (includes illus. nos. 14 through 25)
	882536	1	Noncomputer Sensor Bracket Assembly Complete - Includes Thermostats (for models mfd. prior to May 2, 2000) (includes illus. nos. 14 through 25)
	322062	1	Universal Sensor Bracket ONLY (for models mfd. prior to July 1, 2002)
	322080	1	Universal Sensor Bracket ONLY (for models mfd. between May 2, 2000 and July 1, 2002)
26	122604	1	4-Pin Connector ONLY
27	122700	4	Pin Terminal ONLY
28	150301	2	#8-18 x 7/16" Phillips Pan Head TEK Screw

For Models Mfd. as of September 29, 2000

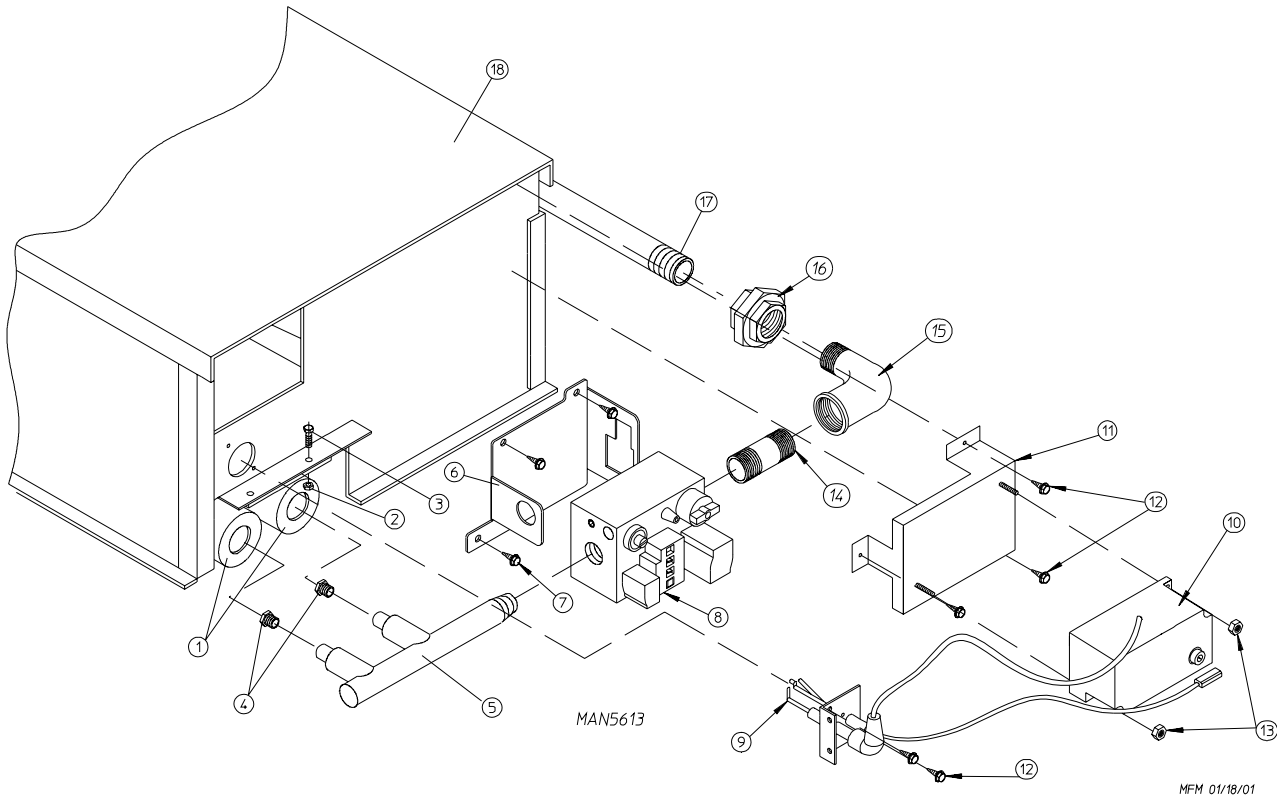

For Models Mfd. as of September 29, 2000

<u>Illus. No.</u>	<u>Part No.</u>	<u>Qty.</u>	<u>Description</u>
1	141104	2	Small Tube Burner
2	151001	2	#8-32 Pal Nut
3	150108	2	#8-32 x 1/2" Phillips Pan Head Machine Screw
4	140818*	2	#31 Orifice (natural gas)
	140802*	2	#50 Orifice (liquid propane [L.P.] gas)
5	141230	1	1/2" Direct Spark Ignition (DSI) Manifold (2-port)
6	318714	1	1-Piece Gas Valve Bracket
7	150309	5	#10-16 x 1/2" Hex Head TEK Crimptite Screw
8	128927	1	Natural Gas Valve
	880960	1	Liquid Propane (L.P.) Gas Valve
9	809307	1	Ignitor-Probe Assembly
10	801048	1	Direct Spark Ignition (DSI) Module (three [3] tries)
11	817027	1	Direct Spark Ignition (DSI) Module Mounting Bracket
12	150300	9	#10-16 x 1/2" Hex Washer TEK Screw
13	152013	2	#6-32 Hex Nut
14	142707	1	1/2" x 1-1/2" Long Black Nipple
15	142506	1	1/2" Street Elbow
16	142600	1	1/2" Black Union
17	142800	1	1/2" x 18" Pipe
18	817058**	1	Direct Spark Ignition (DSI) Burner Box - Natural Gas (includes illus. nos. 1 through 3 and 5 through 18)
	817059	1	Direct Spark Ignition (DSI) Burner Box - Liquid Propane (L.P.) Gas (includes illus. nos. 1 through 3 and 5 through 18)
	817088	1	Direct Spark Ignition (DSI) Burner Box ONLY
	882267	1	AD-25V L.P. Conversion Kit (includes orifices)
	880604***	1	Steam to Gas Interface Assembly

* Consult factory for elevations over 2,000 feet.

** Burner orifices *are not included* and **must be** ordered separately.

*** Needed when converting steam heat to gas heat.

Direct Spark Ignition (DSI) Burner Assembly

For Models Mfd. prior to September 29, 2000

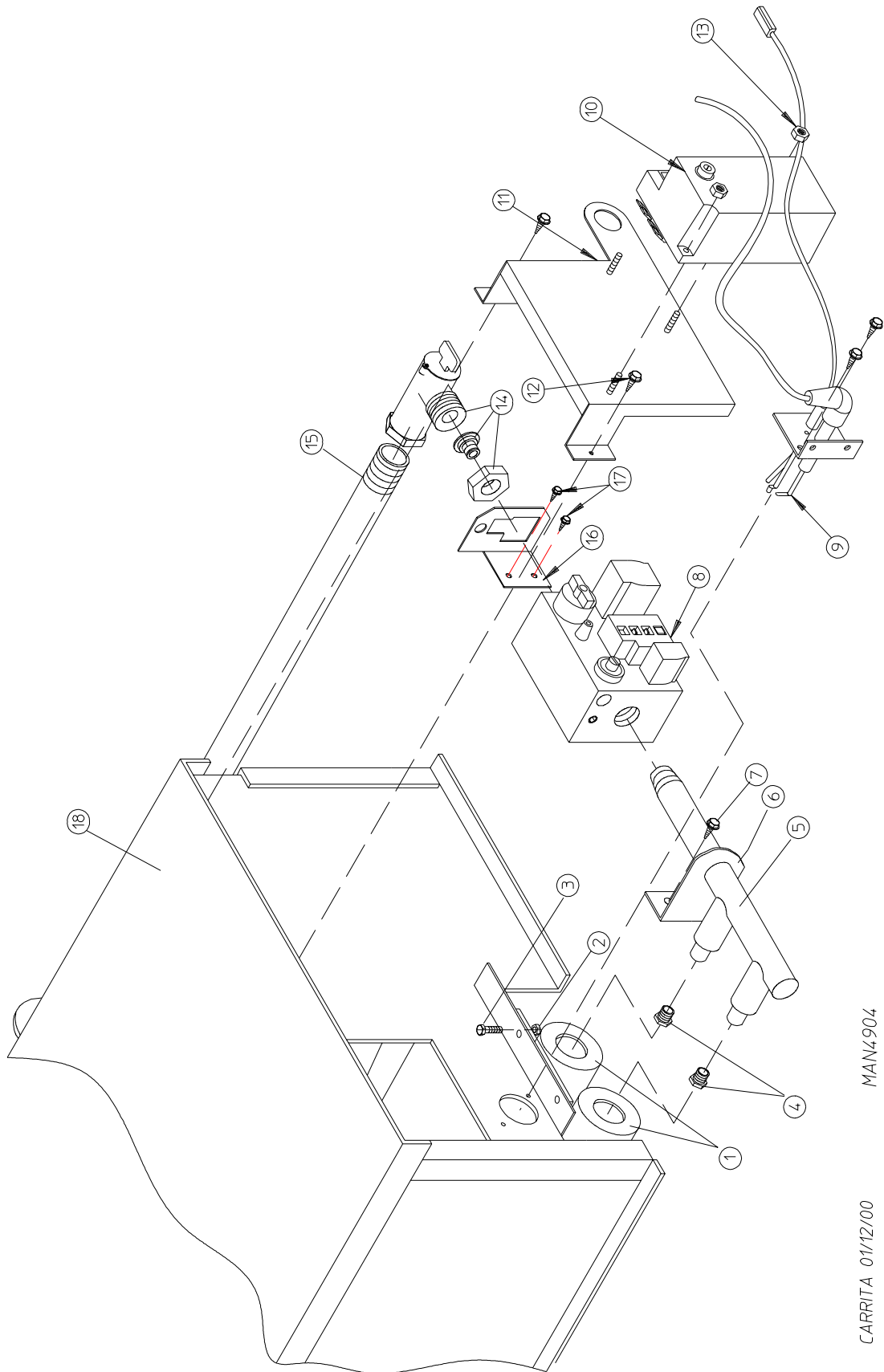

MAN#904

CARRITA 01/12/00

For Models Mfd. prior to September 29, 2000

<u>Illus. No.</u>	<u>Part No.</u>	<u>Qty.</u>	<u>Description</u>
1	141104	2	Small Tube Burner
2	151001	2	#8-32 Pal Nut
3	150108	2	#8-32 x 1/2" Pan Head Machine Screw
4*	140818	2	#31 Burner Orifice (natural gas)
	140802	2	#50 Burner Orifice (liquid propane [L.P.] gas)
5	141230	1	1/2" Direct Spark Ignition (DSI) Manifold (2-port)
6	318700	2	Pipe Bracket (bent)
7	150300	2	#10-16 x 1/2" Hex Washer TEK Screw
8	128927	1	Natural Gas Valve
	880960	1	1/2" Direct Spark Ignition (DSI) Gas Valve with Liquid Propane (L.P.) Kit Combination
9	880134	1	Ignitor Probe Assembly
	882537	1	Flame-Probe Wire
10	128935	1	Johnson Controls Direct Spark Ignition (DSI) Module with Three (3) Tries
11	817027	1	Direct Spark Ignition (DSI) Module Mounting Bracket Assembly
12	150309	3	#10-16 x 1/2" Hex Head TEK Crimptite Screw
13	152013	2	#6-32 Hex Nut
14	141313	1	90° x 1/2" x 1" Gas Shut Off Assembly
15	142800	1	1/2" x 18" Pipe
16	318712	1	Gas Valve Pipe Bracket
17	150309	4	#10-16 x 1/2" Hex Head TEK Crimptite Screw
18	817058**	1	Direct Spark Ignition (DSI) Burner Box - Natural Gas (includes illus. nos. 1 through 3 and 5 through 18)
	817059	1	Direct Spark Ignition (DSI) Burner Box - Liquid Propane (L.P.) Gas (includes illus. nos. 1 through 3 and 5 through 18)
	817088	1	Direct Spark Ignition (DSI) Burner Box ONLY
---	882267	1	AD-25V Liquid Propane (L.P.) Conversion Kit (includes orifices)
***	882604	1	Steam to Gas Interface Assembly

* Consult factory for elevations over 2,000 feet.

** Burner orifices *are not included* and **must be** ordered separately.

*** Needed when converting steam heat to gas heat.

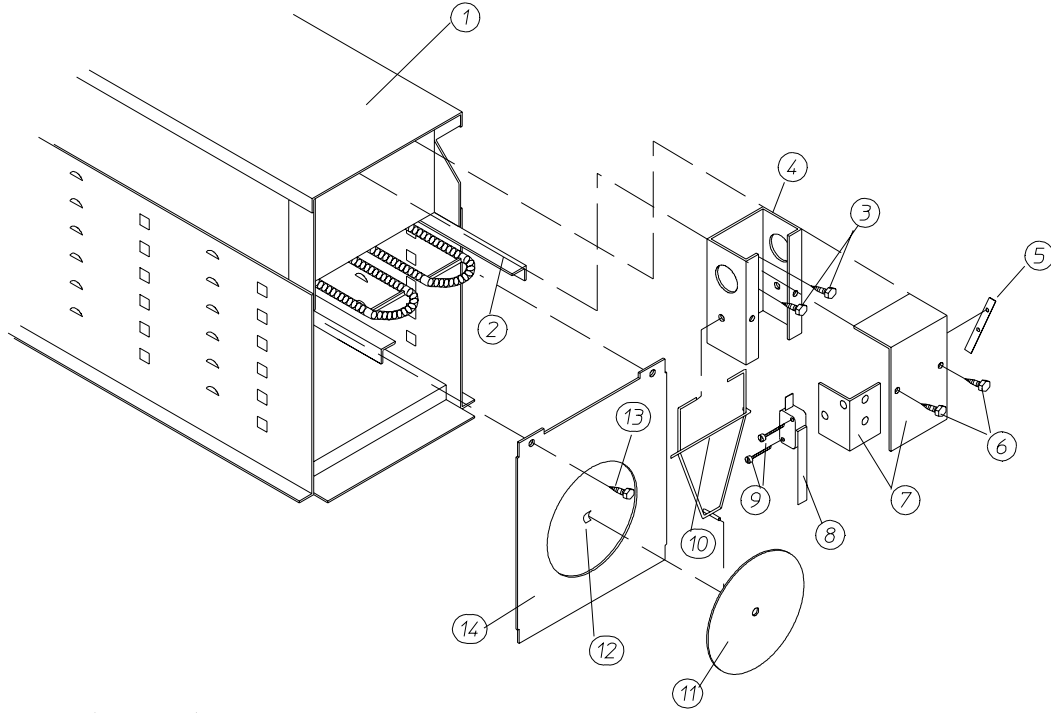

ELECTRIC OVEN (FRONT VIEW)

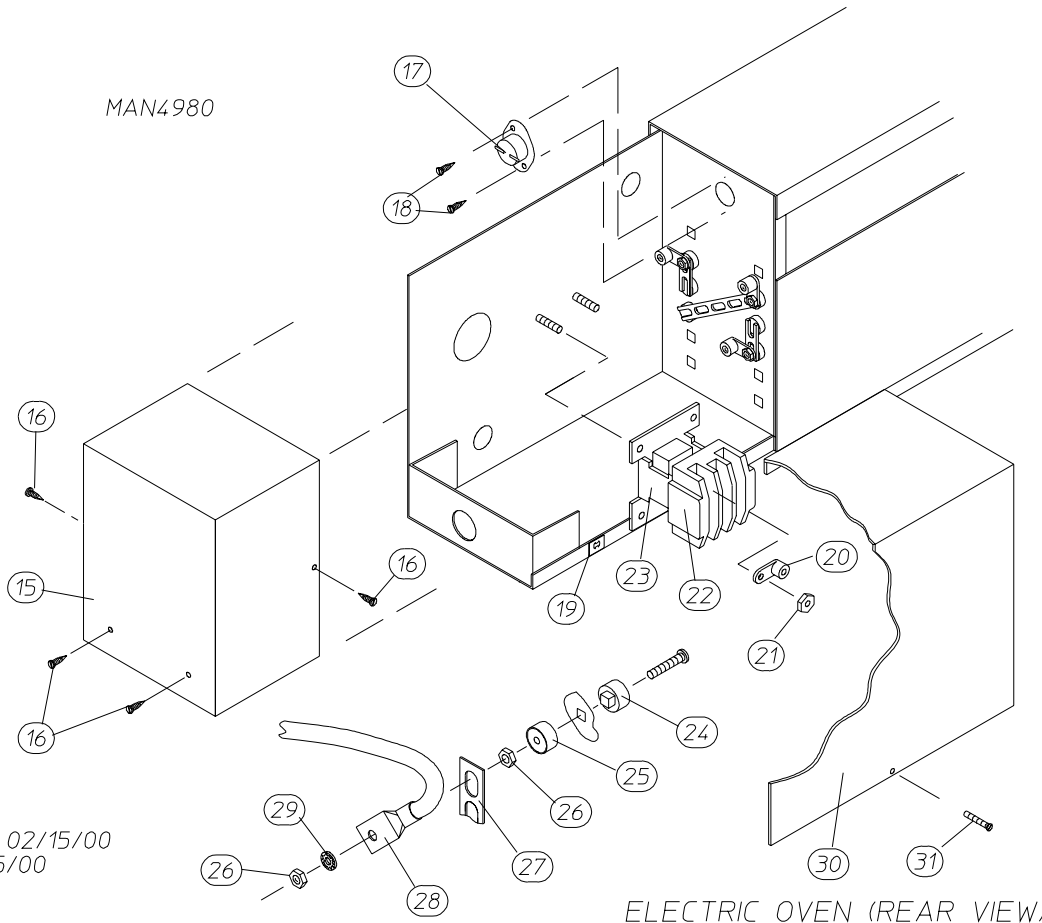

MAN4980

TCOSTA 02/15/00
DX 01/25/00

ELECTRIC OVEN (REAR VIEW)

<u>Illus. No.</u>	<u>Part No.</u>	<u>Qty.</u>	<u>Description</u>
1	803003*	1	Small Electric Oven Box ONLY
	-----*	1	Electric Oven Assembly Complete
2	-----*	-	Electric Element
3	150300	2	#10-16 x 1/2" Hex Washer TEK Screw
4	802800	1	Sail Switch Box with Bracket and Cover ONLY
	802801	1	Sail Switch Box Assembly Complete (includes illus. nos. 4 through 12)
5	154004	1	Twin Speed Nut
6	150309	2	#10-16 x 1/2" Hex Head TEK Crimptite Screw
7	802799	1	Sail Switch Box Cover ONLY
8	122200	1	Sail Switch ONLY
9	150303	2	#4 x 3/4" Pan Head "A" Machine Screw
10	105500	1	Sail Switch Actuator Rod
11	319202	1	Sail Switch Damper (flat)
12	154002	1	1/8" Push On Fastener
13	150300	2	#10-16 x 1/2" Hex Washer TEK Screw
14	803100	1	Electric Oven Front Cover ONLY
15	320611	1	Large Relay Box Cover ONLY
16	150301	3	#8-18 x 7/16 Phillips Pan Head TEK Screw
17	130400	1	290° Hi-Limit Thermostat
18	150300	2	#10-16 x 1/2" Hex Washer TEK Screw
19	154001	1	#10-24 Speed Nut
20	121010	1	L-70 Ground Lug
21	152014	3	1/4-20 Free Spin Wash Nut
22	-----*	1	Oven Relay
23	-----*	1	Oven Relay Replacement Coil
24	120081	-	Internal Ceramic Insulator (2 per element)
25	120080	-	External Ceramic Insulator (2 per element)
26	152008	-	#10-32 Hex Nut (4 per element)
27	121011*	-	Bus Bar
28	-----*	-	Oven Wire with Crimp Lug
29	153009	-	#10 Star Washer (2 per element)
30	321300	1	Small Electric Oven Right Side Cover ONLY
31	150207	1	#10-24 x 1/2" Phillips Head Machine Screw
	882604**	1	Steam to Electric Interface Assembly

* Refer to **Electrical Oven Component Application Chart** on **page 57**.

** Needed when converting steam heat to electric heat.

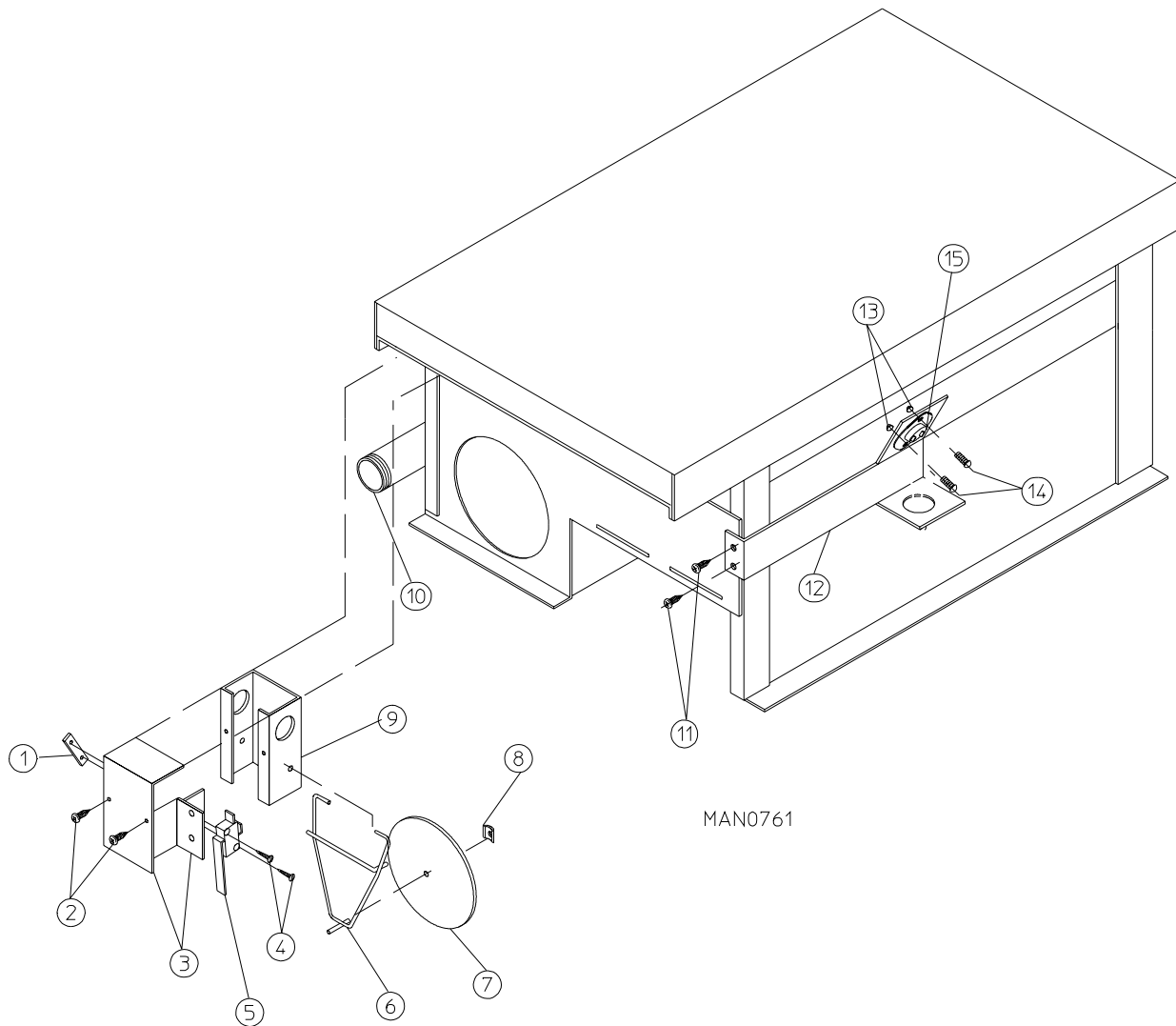

<u>Illus. No.</u>	<u>Part No.</u>	<u>Qty.</u>	<u>Description</u>
1	154004	1	Twin Speed Nut
2	150300	2	#10-16 x 1/2" Hex Washer TEK Screw
3	802799	1	Sail Switch Box Cover and Bracket ONLY
4	150303	2	#4 x 3/4" Pan Head "A" Machine Screw
5	122200	1	Sail Switch ONLY
6	105500	1	Sail Switch Actuator Rod
7	319202	1	Sail Switch Damper (flat)
8	154002	1	1/8" Push On Fastener
9	802800	1	Sail Switch Box with Cover and Bracket ONLY
	802801	1	Sail Switch Assembly Complete (includes illus. nos. 1 through 9)
10	142800	1	1/2" x 18" Pipe
11	150300	2	#10-16 x 1/2" Hex Washer TEK Screw
12	319704	1	Hi-Limit Mounting Bracket ONLY
13	151000	2	#6-32 Pal Nut
14	150001	2	#6-32 x 1/2" Round Head Machine Screw
15	130201	1	330° Hi-Limit Manual Reset Thermostat

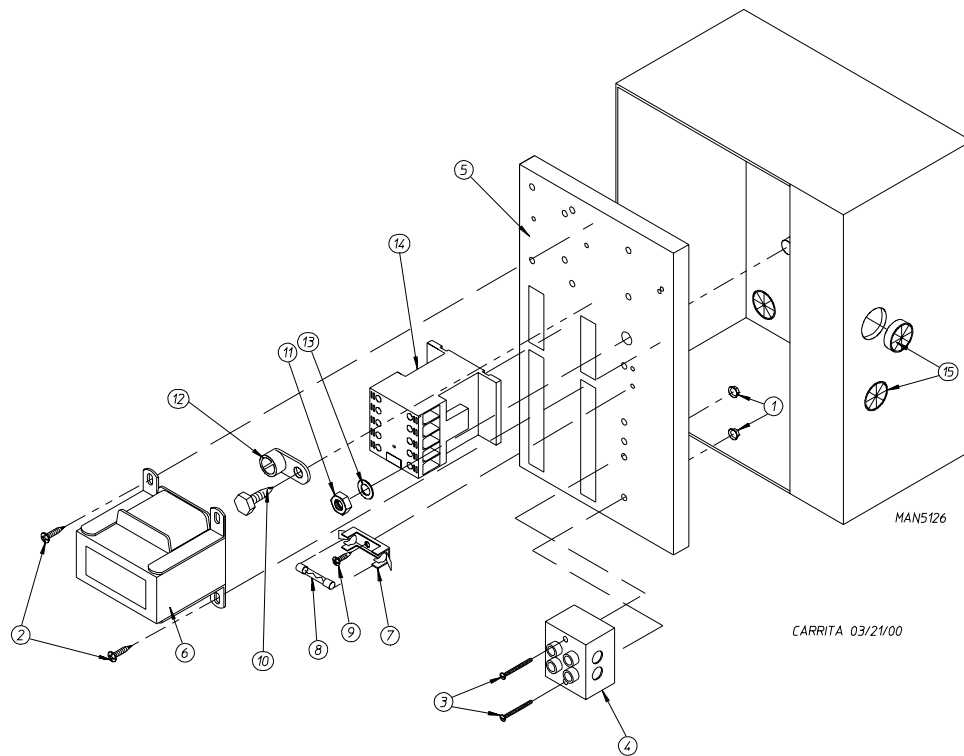

<u>Illus. No.</u>	<u>Part No.</u>	<u>Qty.</u>	<u>Description</u>
1	151000	2	#6-32 Pal Nut
2	150300	2	#10-16 x 1/2" Hex Washer TEK Screw
3	150008	2	#6-32 x 1-1/4" Phillips Pan Head Machine Screw
4	120716	1	2-Position Terminal Block
5	322817	1	Rear Electric Mounting Plate ONLY
	882662	1	Rear Electric Panel Assembly Complete - 120 Volt (includes illus. nos. 1 through 14)
	882663	1	Rear Electric Panel Assembly Complete - 208-240 Volt (for gas and steam heated models Only) (includes illus. nos. 1 through 14)
	818395	1	Rear Electric Panel Assembly Complete - 208-240 Volt (for electric heated models Only) (includes illus. nos. 1 through 14)
6	882652	1	Transformer Assembly - 120 Volt
	882653	1	Transformer Assembly - 208-240 Volt (for gas and steam heated models Only)
	818396	1	Transformer Assembly - 208-240 Volt (for electric heated models Only)
7	136008	1 or 2	Fuse Holder ONLY
8	136049	1	3/4-Amp (Slo-Blo) Fuse ONLY - 120 Volt
	136057	2	1/2-Amp (Slo-Blo) Fuse ONLY - 208-240 Volt
9	150301	1	#8-18 x 7/16" Phillips Pan Head TEK Screw
10	150297	1	#10 x 1/2" Hex Washer TEK Screw (green)
11	152004	1	5/16-18 Hex Nut
12	121010	1	L-70 Ground Lug
13	153002	1	5/16" Lock Washer
14	132459	1	3-Pole Contactor
15	121300	3	Open/Closed Bushing

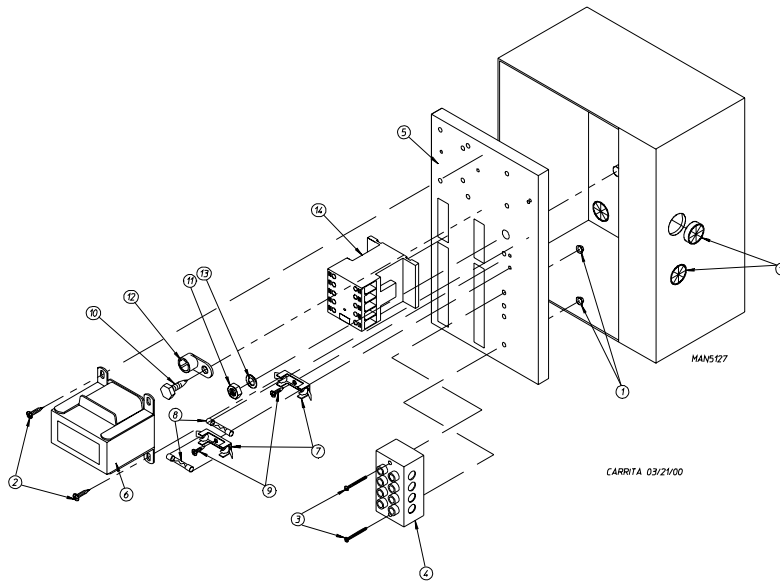

<u>Illus. No.</u>	<u>Part No.</u>	<u>Qty.</u>	<u>Description</u>
1	151000	2	#6-32 Pal Nut
2	150300	2	#10-16 x 1/2" Hex Washer TEK Screw
3	150008	2	#6-32 x 1-1/4" Phillips Pan Head Machine Screw
4	120701	1	4-Position Terminal Block (for models mfd. with 3 ϕ motors)
	120716	1	2-Position Terminal Block (for models mfd. with 1 ϕ motors)
5	322817	1	Rear Electric Mounting Plate ONLY
	882664	1	Rear Electric Panel Assembly Complete - 208-240 Volt For Gas and Steam Models ONLY (includes illus. nos. 1 through 14)
	818400	1	Rear Electric Panel Assembly - 208-240 Volt For Electric Heated Models ONLY (includes illus. nos. 1 through 14)
	882665	1	Rear Electric Panel Assembly Complete - 380-416 Volt For Gas and Steam Models ONLY (includes illus. nos. 1 through 14)
	818395	1	Rear Electric Panel Assembly Complete - 208-240 Volt For Electric Heated Models ONLY For Models Mfd. with Single-Phase (1 ϕ) Motor ONLY (includes illus. nos. 1 through 14)
	882667	1	Rear Electric Panel Assembly Complete - 380-416 Volt For Electric Heated Models ONLY For Models Mfd. with Single-Phase (1 ϕ) Motor ONLY (includes illus. nos. 1 through 14)
6	882653	1	Transformer Assembly - 208-240 Volt for Gas and Steam Models ONLY
	818396	1	Transformer Assembly - 208-240 Volt for Electric Heated Models ONLY
	882654	1	Transformer Assembly - 380-416 Volt
7	136008	2	Fuse Holder ONLY
8	136057	2	1/2-Amp (Slo-Blo) Fuse ONLY
9	150301	2	#8-18 x 7/16" Phillips Pan Head TEK Screw
10	150297	1	#10 x 1/2" Hex Washer TEK Screw (green)
11	152004	1	5/16-18 Hex Nut
12	121010	1	L-70 Ground Lug
13	153002	1	5/16" Lock Washer
14	132459	1	3-Pole Contactor
15	121300	3	Open/Closed Bushing

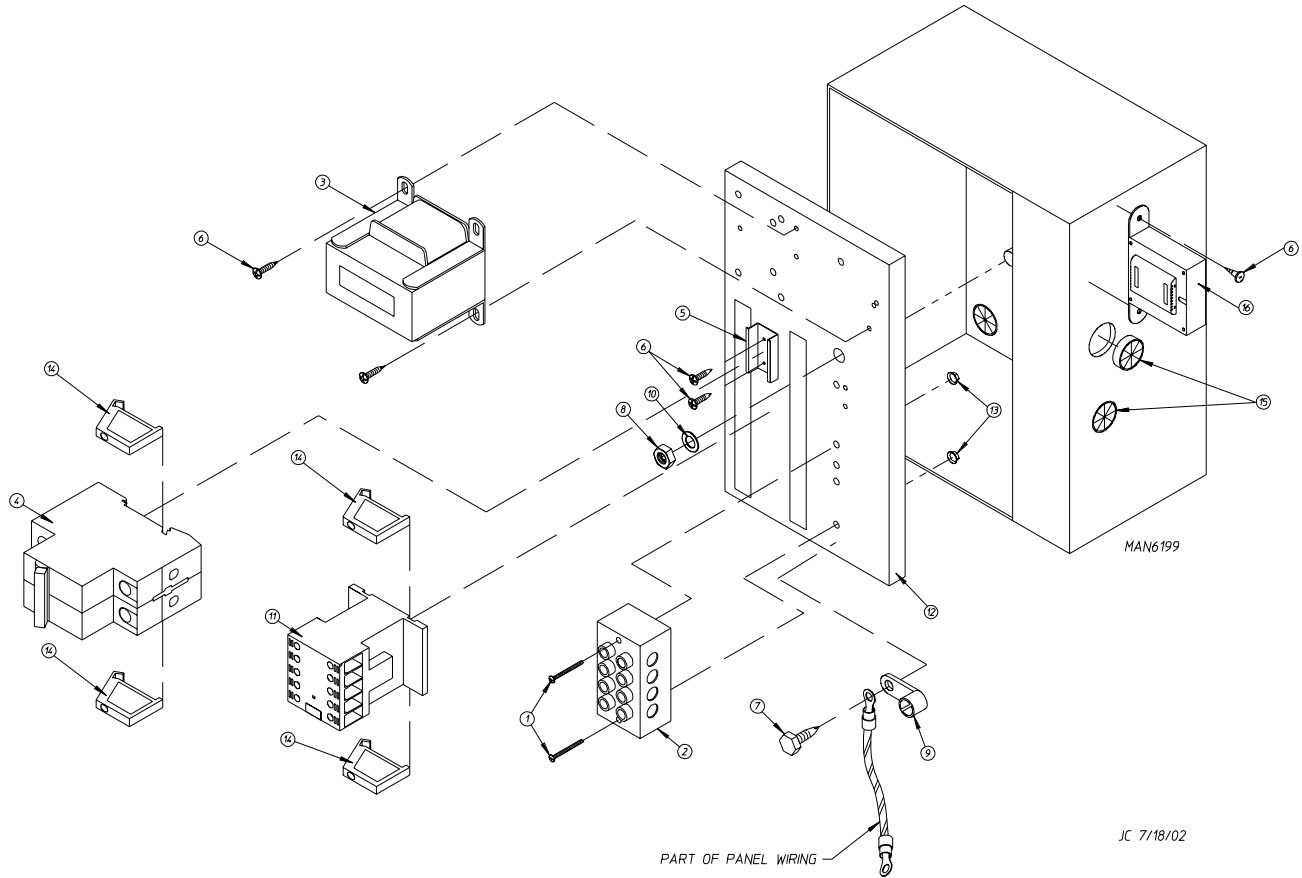

<u>Illus. No.</u>	<u>Part No.</u>	<u>Qty.</u>	<u>Description</u>
1	150009	2	#6-32 x 1-1/2" Phillips Pan Head Machine Screw
2	120701	1	4-Position Terminal Block
3	830208	1	Transformer Assembly (460 VAC) for Micro Models ONLY
	824161	1	Transformer Assembly (460 VAC) for Non-Micro Models ONLY
4	135501	1	1-Amp Double-Pole Circuit Breaker (460 VAC Only)
5	120768	2	35 x 15mm Din Rail
6	150301	4	#8-18 x 7/16" Phillips Pan Head TEK Screw
7	150297	2	#10 x 1/2" Ground Screw
8	152004	1	5/16-18 Hex Nut
9	121010	1	L-70 Ground Lug
10	153002	1	5/16" Lock Washer
11	132459	1	24 VAC 3-Pole Contactor
12	322817	1	Mounting Plate ONLY
	883332	1	Rear Panel Assembly Complete (460 VAC) for Micro Models ONLY (includes illus. nos. 1 through 14)
	830262	1	Rear Panel Assembly Complete (460 VAC) for Non-Micro Models ONLY (includes illus. nos. 1 through 14)
13	151000	2	#6-32 Pal Nut
14	120765	4	End Stop
15	121300	1	Open/Closed Bushing
16	141403	1	Control Voltage Transformer (24V) for Micro Models ONLY

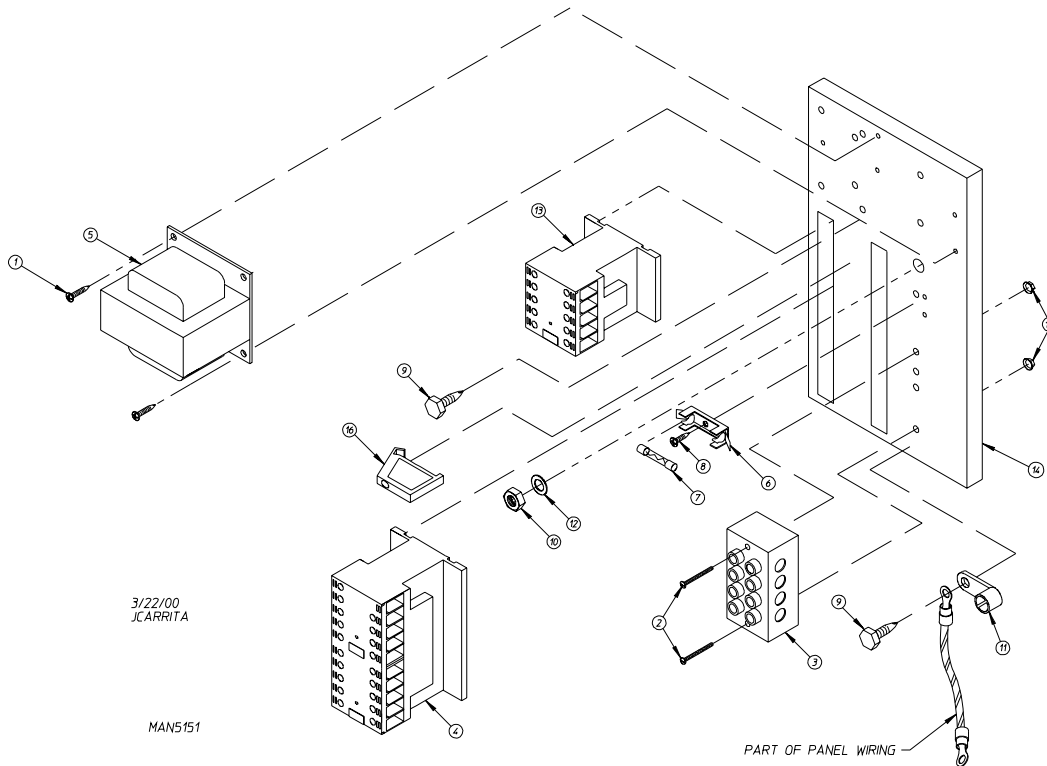

<u>Illus. No.</u>	<u>Part No.</u>	<u>Qty.</u>	<u>Description</u>
1	150300	2	#10-16 x 1/2" Hex Washer TEK Screw
2	150008	2	#6-32 x 1-1/4" Phillips Pan Head Machine Screw
3	120701	1	4-Position Terminal Block
4	132458	1	3-Pole Reversing Contactor
5	882653	1	Transformer Assembly - 208-240 Volt for Gas and Steam Models ONLY
	825428	1	Transformer Assembly - 208-240 Volt for Electric Heated Models ONLY
	882654	1	Transformer Assembly - 380-416 Volt
6	136008	1	Fuse Holder ONLY
7	136057	1	1/2-Amp (Slo-Blo) Fuse ONLY - 208-240 Volt
8	150301	1	#8-18 x 7/16" Phillips Pan Head TEK Screw
9	150297	1	#10 x 1/2" Hex Washer TEK Screw (green)
10	152004	1	5/16-18 Hex Nut
11	121010	1	L-70 Ground Lug
12	153002	1	5/16" Lock Washer
13	132459	1	3-Pole Contactor
14	322812	1	Rear Electric Mounting Plate ONLY
	882673	1	Rear Electric Panel Assembly Complete - 208-240 Volt For Gas and Steam Models ONLY (includes illus. nos. 1 through 16)
	883335	1	Rear Electric Panel Assembly Complete - 208-240 Volt For Electric Heated Models ONLY (includes illus. nos. 1 through 16)
	882676	1	Rear Electric Panel Assembly Complete - 380-416 Volt (includes illus. nos. 1 through 16)
15	151000	2	#6-32 Pal Nut
16	120765	1	Standard End Bracket

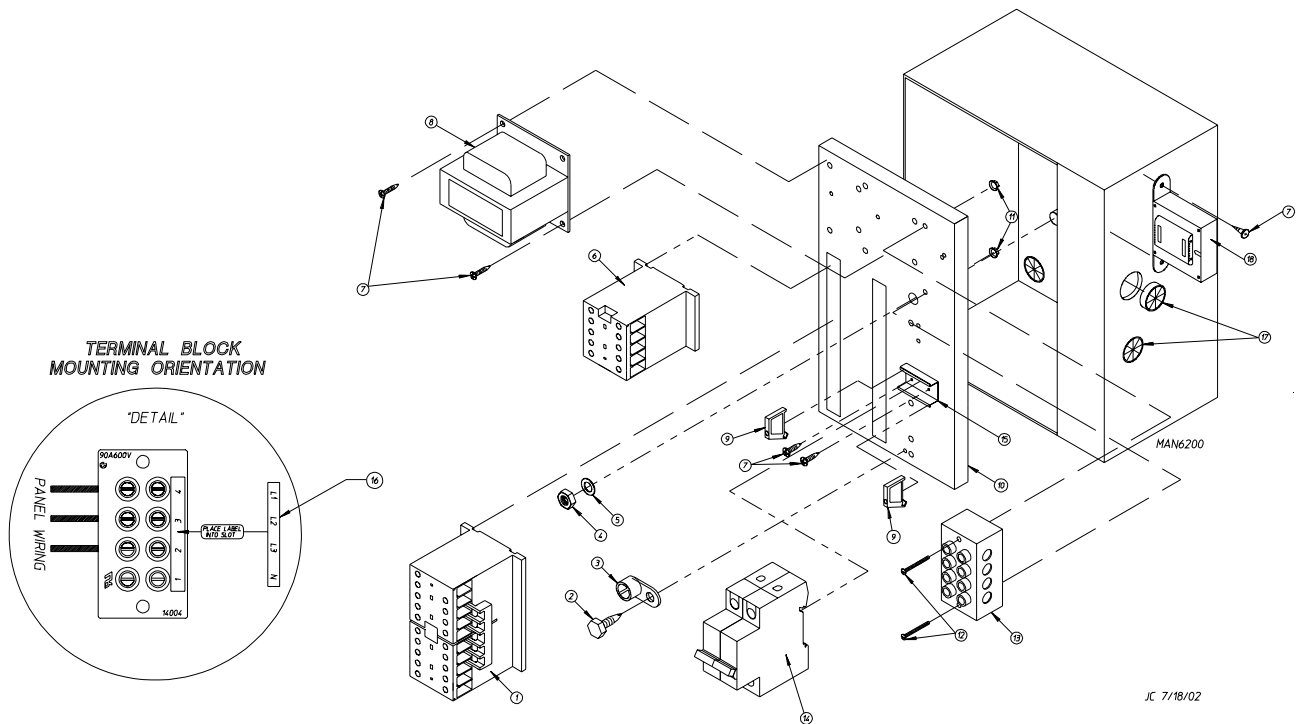

<u>Illus. No.</u>	<u>Part No.</u>	<u>Qty.</u>	<u>Description</u>
1	132458	1	24 VAC Reversing Contactor
2	150297	1	#10 x 1/2" Hex Head TEK Screw (green)
3	121010	1	L-70 Ground Lug
4	152004	1	5/16-18 Hex Nut
5	153002	1	5/16" Lock Washer
6	132459	1	24 VAC 3-Pole Blower Contactor
7	150300	4	#10-16 x 1/2" Hex Washer TEK Screw
8	830208	1	Transformer Assembly (460 VAC) for Micro Models ONLY
	824161	1	Transformer Assembly (460 VAC) for Non-Micro Models ONLY
9	120765	2	End Stop
10	322817	1	Mounting Plate ONLY
	883327	1	460 VAC Reversing Rear Electric Panel Assembly Complete For Micro Models ONLY (includes illus. nos. 1 through 16)
	-----*	1	460 VAC Reversing Rear Electric Panel Assembly Complete For Non-Micro Models ONLY (includes illus. nos. 1 through 16)
11	151000	2	#6-32 Pal Nut
12	150009	2	#6-32 x 1-1/2" Phillips Pan Head Machine Screw
13	120701	1	4-Position Terminal Block
14	135501	1	1-Amp Double-Pole Circuit Breaker
15	120768	2	35 x 15mm Din Rail (sold by the inch)
16	112068	1	3-Phase (3 ϕ) Power Input Label
17	121300	1	Open/Closed Bushing
18	141403	1	Control Voltage Transformer (24V) for Micro Models ONLY

* Not available at time of printing. Contact factory for additional information.

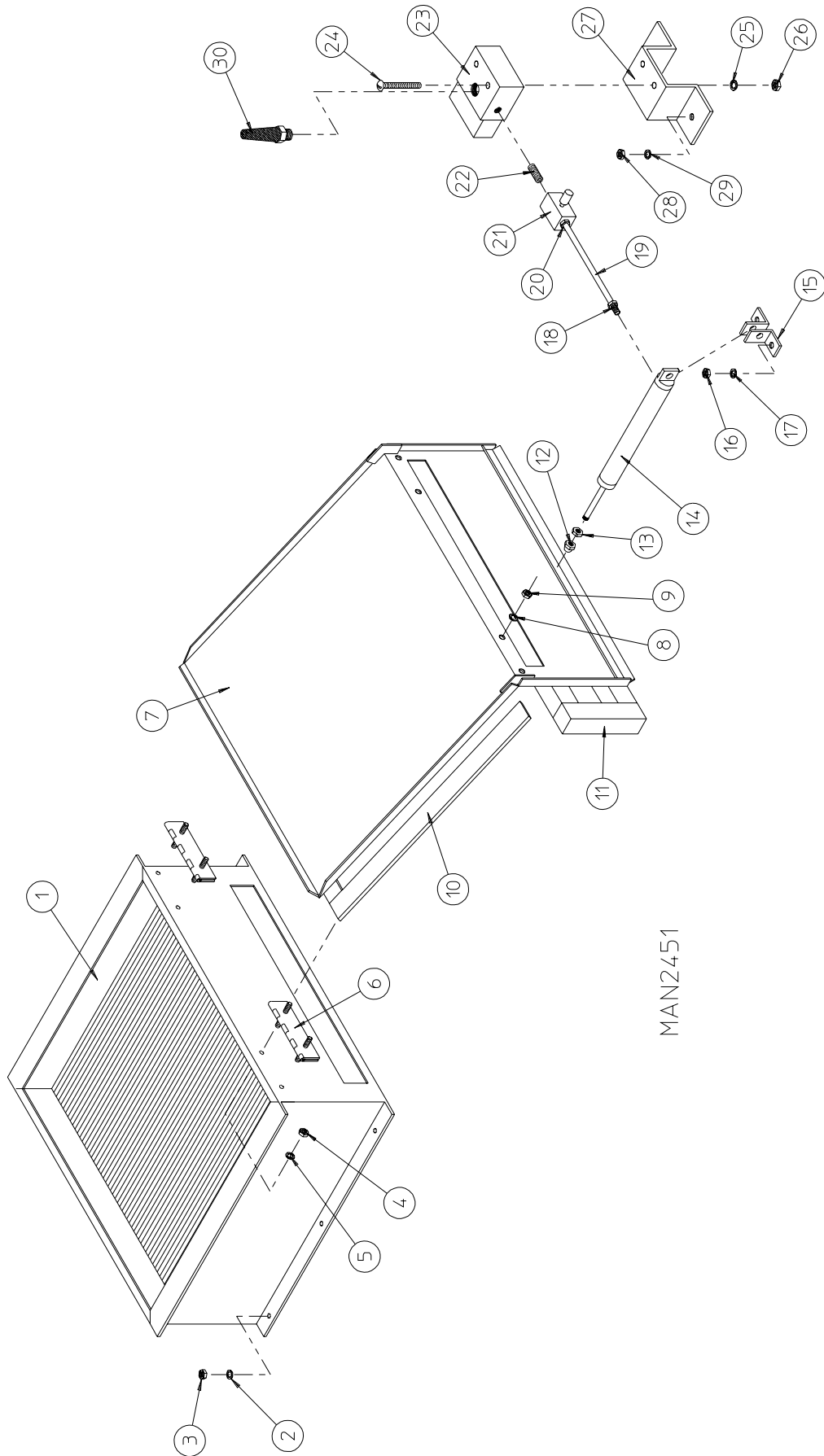

<u>Illus. No.</u>	<u>Part No.</u>	<u>Qty.</u>	<u>Description</u>
1	165013	1	Steam Coil Assembly
2	153002	6	5/16" Lock Washer
3	152004	6	5/16-18 Hex Nut
4	152002	4	1/4-20 Hex Nut
5	153007	4	1/4" Lock Washer
6	820321	2	Steam Damper Hinge Assembly
7	880835	1	Steam Damper Assembly (includes illus. nos. 7, 10, and 11)
8	153007	4	1/4" Lock Washer
9	152002	4	1/4-20 Hex Nut
10	115995	48	Steam Damper Gasket (sold by the inch)
11	102350	1	Steam Damper Foam (68-1/2" length)
12	151006	1	5/16-24 Stainless Steel Acorn Nut
13	152051	1	5/16-24 Right Hand Jam Nut
14	100495	1	11/16" Dia. x 3" Stroke Piston
15	323365	2	Left and Right Piston Support
16	152002	2	1/4-20 Hex Nut
17	153007	2	1/4" Lock Washer
18	100472	1	1/4" Poly x 1/8" M.P.T. Connector
19	143110	1	1/4" Poly-Flo Tubing
20	100472	1	1/4" Poly x 1/8" M.P.T. Connector
21	100496	1	1/8" Needle Valve
22	143238	1	1/8" Brass Close Nipple
23	100498	1	3-Way Micro Valve - 24 VAC
24	150002	2	#6-32 x 1" Phillips Round Head Machine Screw
25	153010	2	#6 Star Washer
26	152000	2	#6-32 Hex Nut
27	330987	1	Micro Valve Support
28	152002	2	1/4-20 Hex Nut
29	153007	2	1/4" Lock Washer
30	100520	1	1/8" N.P.T. Silencer (muffler)

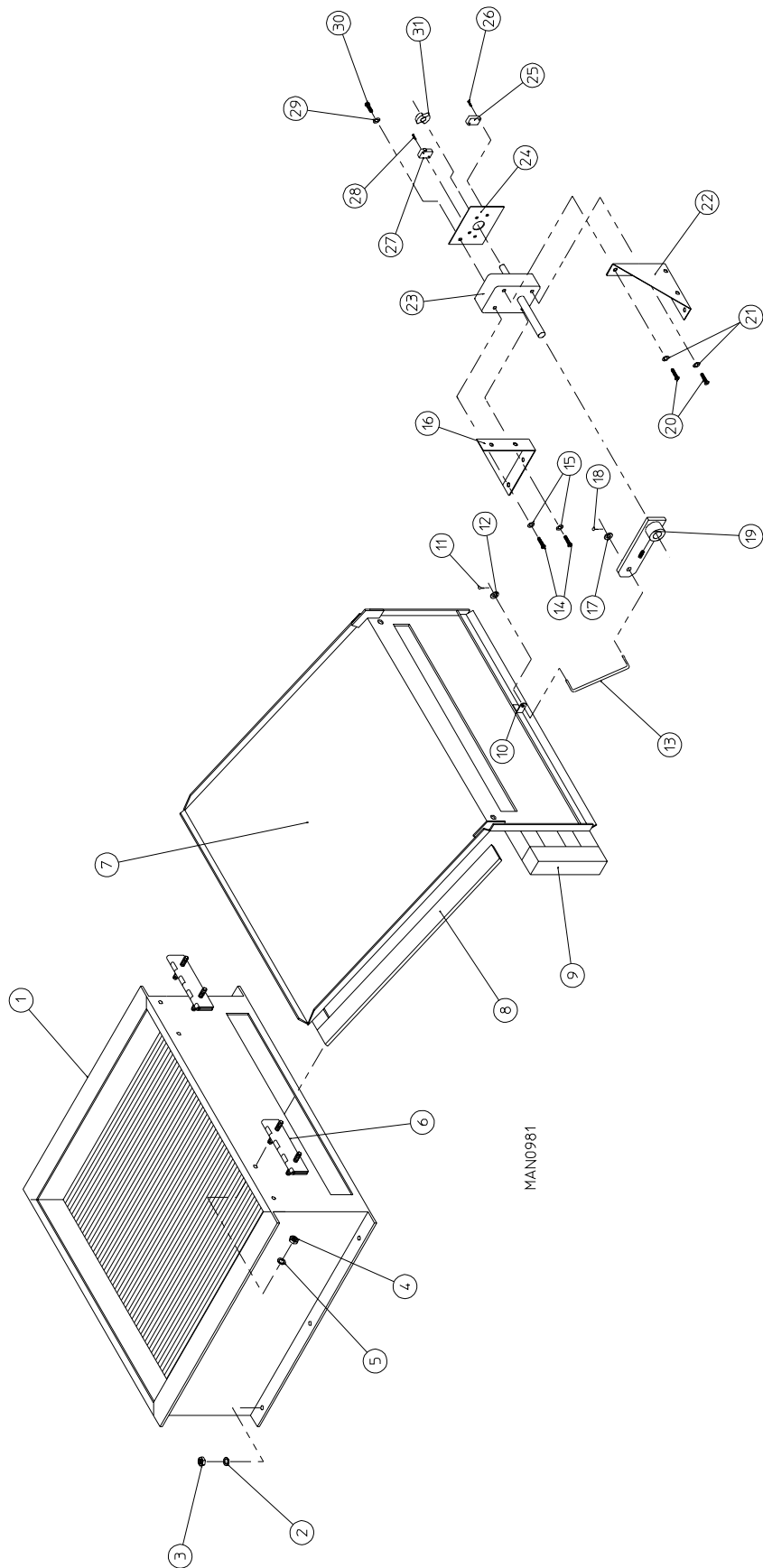

<u>Illus. No.</u>	<u>Part No.</u>	<u>Qty.</u>	<u>Description</u>
1	165013	1	Steam Coil Assembly ONLY
2	153002	6	5/16" Lock Washer
3	152004	6	5/16-18 Hex Nut
4	152002	4	1/4-20 Hex Nut
5	153007	4	1/4" Lock Washer
6	820321	2	Steam Damper Hinge Assembly
7	880835	1	Steam Damper Assembly (includes illus. nos. 7, 8, and 9)
8	115995	48	Steam Damper Gasket (sold by the inch)
9	102350	1	68-1/2" Long Steam Damper Foam
10	309300	1	Rod Bracket
11	154300	1	1/2" x 3/32" Cotter Pin
12	153002	1	#10 Steel Burr
13	104052	1	Mechanical Steam Damper Actuator Rod
14	150110	2	#8-32 x 1/4" Phillips Round Head Machine Screw
15	153012	2	#8 Star Washer
16	312315	1	Mechanical Steam Damper Motor Mount
17	153022	1	#10 Steel Burr
18	154300	1	1/2" x 3/32" Cotter Pin
19	850268	1	Mechanical Steam Damper Arm
20	150110	2	#8-32 x 1/4" Phillips Head Machine Screw
21	153012	2	#8 Star Washer
22	312315	1	Mechanical Steam Damper Motor Mount
23	104054	1	Mechanical Steam Damper Motor
24	100511	1	Mechanical Steam Damper Switch Plate
25	122120	1	Mechanical Steam Damper Switch
26	150026	2	#4-40 x 5/8" Phillips Pan Head Machine Screw
27	122120	1	Mechanical Steam Damper Switch
28	150026	2	#4-40 x 5/8" Phillips Pan Head Machine Screw
29	153012	2	#8 Star Washer
30	150102	2	#8-32 x 3/8" Pan Head Machine Screw
31	-----*	1	Mechanical Steam Damper Motor Cam

* The mechanical steam damper motor cam is part of the mechanical steam damper motor.

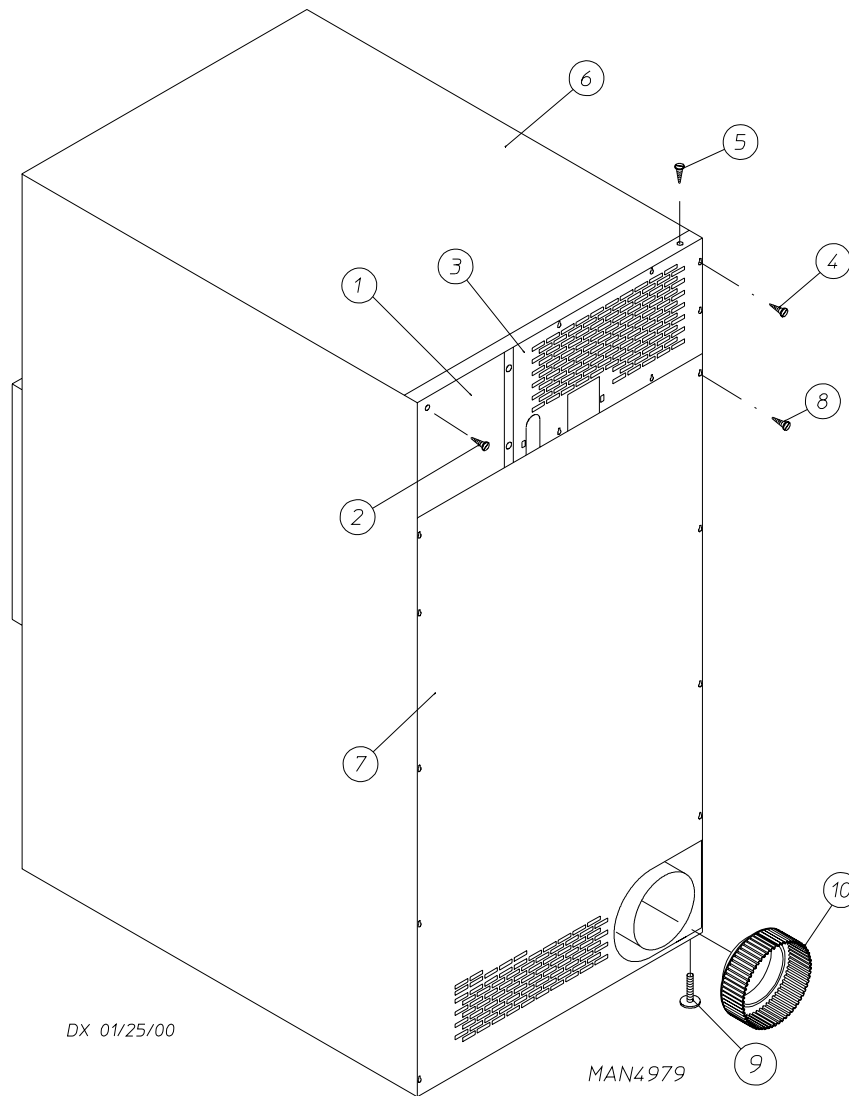

<u>Illus. No.</u>	<u>Part No.</u>	<u>Qty.</u>	<u>Description</u>
1	322809	1	Back Electrical Box Cover
2	150301	4	#8-18 x 7/16" Phillips Pan Head TEK Screw
3*	314424	1	Gas Top Back Guard
	322075	1	Electric Top Back Guard
4	150301	7	#8-18 x 7/16" Phillips Pan Head TEK Screw
5	150300	10	#10-16 x 1/2" Hex Washer TEK Screw
6*	312545	1	Outer Top
7	322082	1	Bottom Back Guard
			(for models mfd. as of March 19, 2001)
	322018	1	Bottom Back Guard
			(for models mfd. prior to March 19, 2001)
8	150301	13	#8-18 x 7/16" Phillips Pan Head TEK Screw
9	103500	4	Leveling Leg
10	882099	1	8" to 10" Transition Piece
			(for models mfd. prior to March 19, 2001)

* There is no outer top or top back guard on steam models.

NOTE: Coin acceptors listed include optical switch.
 Replacement optic switch for Hanke acceptors is Part No. 881143.
 Replacement optic switch for Greenwald acceptors is Part No. 137056.

Single Coin*

<u>ADC Part No.</u>	<u>Nation</u>	<u>Description</u>
883363	United States	25¢ Hanke Optic Coin Acceptor with Four (4) Studs (for models mfd. as of June 25, 2002)
882689	United States	25¢ Hanke Optic Coin Acceptor (for models mfd. between June 15, 2000 and June 25, 2002)
125100	U.S. and Canada	25¢ Greenwald Optic Coin Acceptor (for models mfd. prior to June 15, 2000)
125107	Australia	20¢ Greenwald Australian Optic Coin Acceptor
881768	Australia	\$1 Hanke Australian Optic Coin Acceptor
881604	Japan	100 Yen Hanke Optic Coin Acceptor
125103	---	0.882 Token Greenwald Optic Coin Acceptor
125121	---	0.800 Token Greenwald Optic Coin Acceptor
125133	Hong Kong	\$1 Greenwald Hong Kong Optic Coin Acceptor

Dual Coin*

881508	U.S. and Canada	10¢ / 25¢ Hanke Dual Optic Coin Acceptor
881842	Canada	25¢ / \$1 Hanke Dual Optic Coin Acceptor
881542	United Kingdom	1£ / 20 Pence Hanke Dual Optic Coin Acceptor
881846	France	2 / 5 Franc Hanke Dual Optic Coin Acceptor
881541	Netherlands	25¢ / 1 Guilder Hanke Dual Optic Coin Acceptor

* Consult factory for coin acceptors not listed.

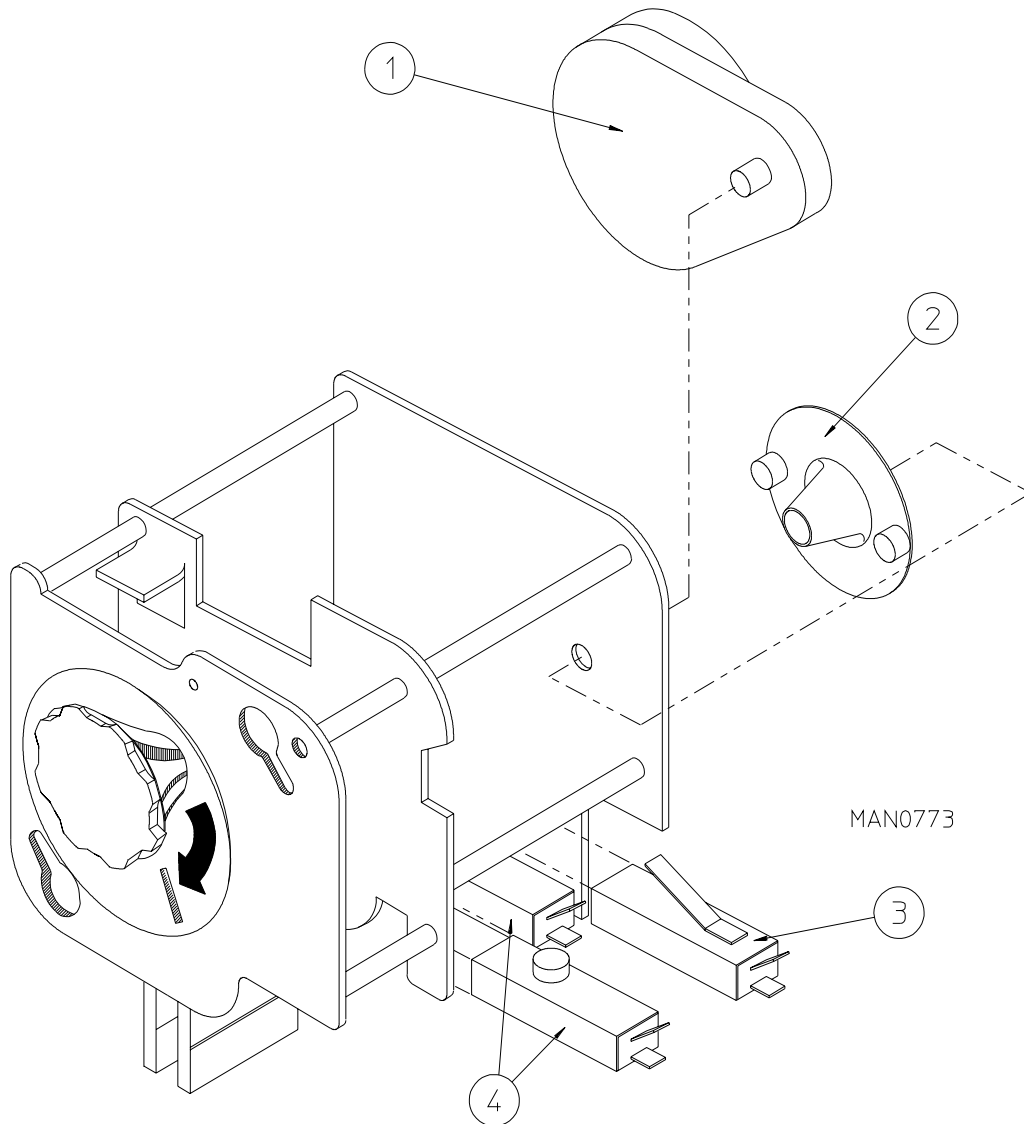

<u>Illus. No.</u>	<u>Part No.</u>	<u>Qty.</u>	<u>Description</u>
1	125541	1	1/60 RPM 24 VAC / 60 Hz Meter Motor
	125540	1	1/30 RPM 24 VAC / 50 Hz Meter Motor
2	125500	1	2-Point Cam
	125501	1	3-Point Cam
	125502	1	4-Point Cam
	125503	1	5-Point Cam
	125504	1	6-Point Cam
	125506	1	8-Point Cam
	125507	1	9-Point Cam
	125508	1	10-Point Cam
	125510	1	12-Point Cam
	3	125515	1
4	125516	2	Meter Switch "A" or "C"

kW	Voltage	Phase	Wire	Oven Assembly	Element			Oven Wire			Terminal Lug		Bus Bar P/N: 121011	Oven Relay	
					Qty	Kw	Part No.	Qty	Size	Part No.	Qty	Part No.		Cat. No.	Part No.
24	460/480	3Ø	3 or 4	824951	6	4	120009	1	#8	882559	1	121010	2	DPA33	131352
24	416	3Ø	3 or 4	826394	6	4	120009	1	#8	882558	1	121010	1	DPA33	131352
24	240	3Ø	3	883557	6	4	120009	1	#6	882556	1	121010	1	DPA63	131369
24	208	3Ø	3 or 4	824915	6	4	120008	1	#4	882553	1	121010	1	DPA73	131376
20	380	3Ø	3 or 4	826243	6	4	120007	1	#8	882558	1	121010	1	DPA33	131352
20	240	1Ø	2	883559	5	4	120009	1	#4	882552	1	121010	2	DPA93	131358
20	208	1Ø	2	883561	5	4	120008	1	#2	883384	1	121010	2	DPA93	131358
18	460/480	3Ø	3 or 4	883560	6	3	120007	1	#8	882559	1	121010	2	DPA33	131352
18	416	3Ø	3 or 4	826389	6	3	120007	1	#8	882558	1	121010	1	DPA33	131352
18	240	3Ø	3	883562	6	3	120007	1	#8	882558	1	121010	2	DPA43	131357
18	240	1Ø	2	883558	6	3	120007	1	#4	882552	1	121010	2	DPA73	131376
18	208	3Ø	3 or 4	824914	6	3	120006	1	#6	882556	1	121010	2	DPA53	131359
18	208	1Ø	2	883563	6	3	120006	1	#2	883384	1	121010	2	DPA93	131358
15	380	3Ø	3 or 4	826389	6	3	120007	1	#8	882558	1	121010	1	DPA33	131352

<u>Part No.</u>	<u>Description</u>
114006	“WARNING - Fire Hazards” Label
112280	“Clean Lint Screen” Label
114001	“CAUTION - Exhaust/Lint Screen” Label
112533	“Phase 5 Coin Program Location Summary” Label
112534	“Phase 5 OPL Program Location Summary” Label
120100	3/8” Straight (BX) Connector
120300	3/8” x 45° (BX) Connector
120400	3/8” Red Jacket (BX) Insulator
120500	3/8” Jiffy Clip (BX) Retainer Clip
120600	3/8” Greenfield (BX)
120707	(2-Position) Terminal Strip
120708	(3-Position) Terminal Strip
120800	1/4” In-Line Connector
120802	Red Butt Connector
120902	#74B Wire Nut
120903	Crimp-on Wire Nut
121014	1/4” Insulated (female) Terminal
121026	Tab Receptacle Combination
121499	5-1/2” Harness Tie
121500	8” Harness Tie
122804	Manometer (Hydro Gauge) for Measuring Gas Pressure
404500	Almond Brush-In-Cap Bottle Touch-Up Paint
404502	White Brush-In-Cap Bottle Touch-Up Paint
404513	Wrinkle Blue Brush-In-Cap Bottle Touch-Up Paint

ADC450342

1 - 05/08/00-25

2* 09/24/01-25

3* 10/10/02-25

