



# **ML-122**

# **Parts Manual**

# **Phase 7**

---

---

**American Dryer Corporation**  
88 Currant Road  
Fall River, MA 02720-4781  
Telephone: (508) 678-9000 / Fax: (508) 678-9447  
E-mail: [techsupport@amdry.com](mailto:techsupport@amdry.com)  
[www.amdry.com](http://www.amdry.com)

# Retain This Manual In A Safe Place For Future Reference

American Dryer Corporation products embody advanced concepts in engineering, design, and safety. If this product is properly maintained, it will provide many years of safe, efficient, and trouble-free operation.

*ONLY qualified technicians should service this equipment.*

**OBSERVE ALL SAFETY PRECAUTIONS** displayed on the equipment or specified in the installation manual included with the dryer.

The following “**FOR YOUR SAFETY**” caution **must be** posted near the dryer in a prominent location.

**FOR YOUR SAFETY**

Do not store or use gasoline or other flammable vapors and liquids in the vicinity of this or any other appliance.

**POUR VOTRE SÉCURITÉ**

Ne pas entreposer ni utiliser d'essence ni d'autres vapeurs ou liquides inflammables à proximité de cet appareil ou de tout autre appareil.

We have tried to make this manual as complete as possible and hope you will find it useful. ADC reserves the right to make changes from time to time, without notice or obligation, in prices, specifications, colors, and material, and to change or discontinue models.

## Important

For your convenience, log the following information:

DATE OF PURCHASE \_\_\_\_\_ MODEL NO. **ML-122 Phase 7**

RESELLER'S NAME \_\_\_\_\_

Serial Number(s) \_\_\_\_\_

\_\_\_\_\_

\_\_\_\_\_

Replacement parts can be obtained from your reseller or the ADC factory. When ordering replacement parts from the factory, you can FAX your order to ADC at (508) 678-9447 or telephone your order directly to the ADC Parts Department at (508) 678-9000. Please specify the dryer **model number** and **serial number** in addition to the **description** and **part number**, so that your order is processed accurately and promptly.

The illustrations on the following pages may not depict your particular dryer exactly. The illustrations are a composite of the various dryer models. Be sure to check the descriptions of the parts thoroughly before ordering.

**“IMPORTANT NOTE TO PURCHASER”**

Information **must be** obtained from your local gas supplier on the instructions to be followed if the user smells gas. These instructions **must be** posted in a prominent location near the dryer.

# ***Table of Contents***

Control Door Assembly .....	2
Phase 7 OPL Microprocessor Control Panel Assembly .....	3
Wrapper Assembly .....	4
Front Panel Assembly .....	5
Cold Rolled Steel (CRS) Door Assembly .....	6
Main Door Switch Assembly .....	7
Lint Drawer/Lint Screen Assembly .....	8
Microprocessor Temperature Sensor Bracket .....	9
Motorized Impellor Assembly .....	10
Basket (Tumbler) Assembly .....	11
Phase 7 Rotational Sensor Assembly .....	12
Drive Shaft Assembly .....	13
Idler Shaft Assembly .....	14
Drive Motor Assembly .....	15
Direct Spark Ignition (DSI) Natural Gas Burner Assembly .....	16, 17
Liquid Propane (L.P.) Gas Burner Assembly .....	18, 19
72 Kw Electric Oven Assembly .....	20
Oven Relay Box Assembly .....	21
Steam Damper Assembly .....	22, 23
Sail Switch Assembly .....	24
Pneumatic Valve Assembly .....	25
Reversing Relay Panel Assembly	
For 60 Hz Gas and Steam Models Only .....	26, 27
Reversing Relay Panel Assembly	
For 50 Hz Gas and Steam Models Only .....	28, 29
Reversing Relay Panel Assembly	
For 60 Hz Electric Models Only .....	30
Air Jet Assembly .....	31
F.S.S. Temperature Probe Assembly .....	32
F.S.S. Solenoid Assembly .....	33
Back Draft Damper Assembly .....	34

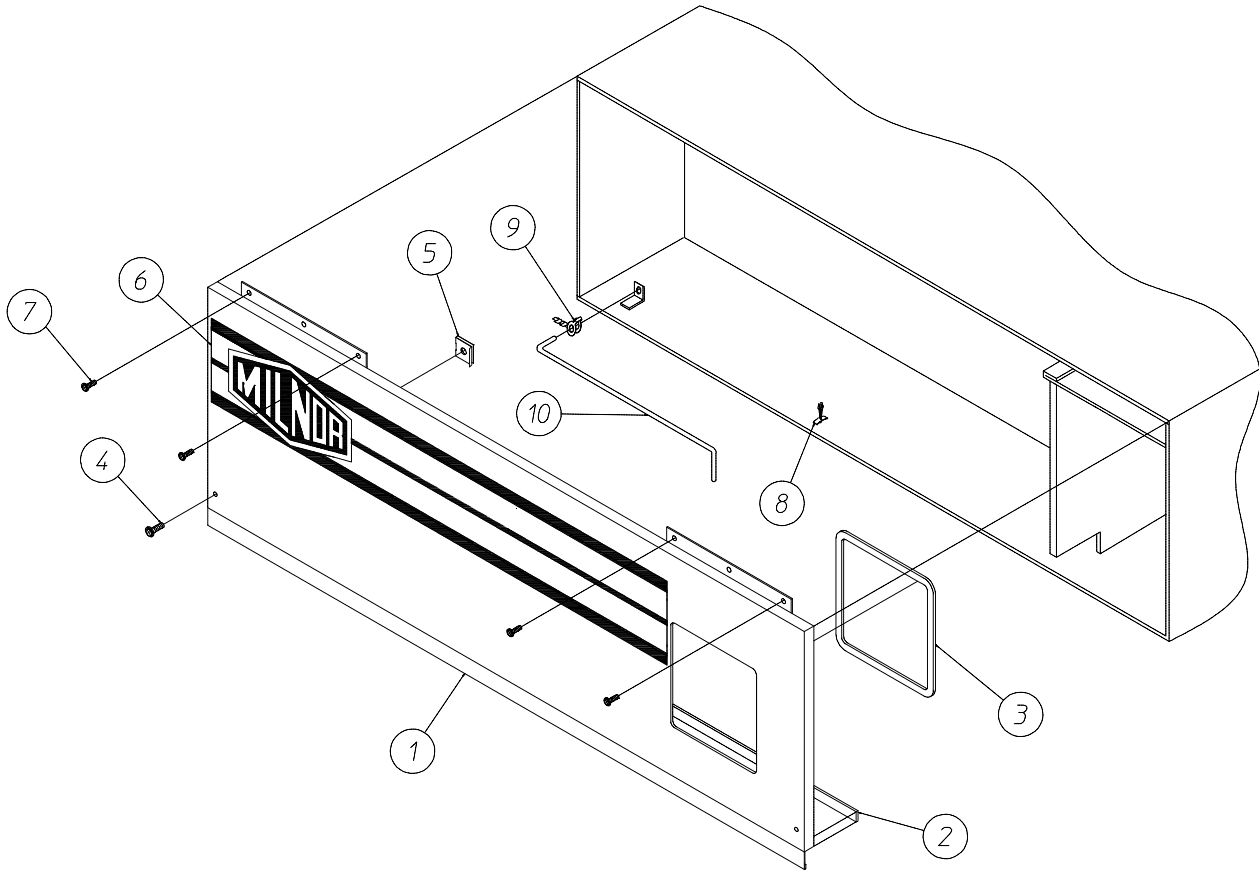

MAN5970

MFM 11/16/01

<u>Illus. No.</u>	<u>Part No.</u>	<u>Qty.</u>	<u>Description</u>
1	883316*	1	Control Door (includes illus. nos. 2, 3, and 8)
2	117603	2	1/8" x 9/16" Noise Suppressor Tape
3	117604	4	Neoprene Sponge Tape (sold by the foot)
4	150314	2	#10-32 x 1/2" TORX Screw
5	154011	2	#10-32 Multi-Thread U-Nut
6	112368	1	Logo ONLY
7	150309	4	#10-16 x 1/2" Hex Head TEK Crimptite Screw
8	102603	1	Control Door Rod Support Catch
9	102601	1	Control Door Retainer Clip
10	102502	1	Control Door Rod

\* Specify color when ordering.

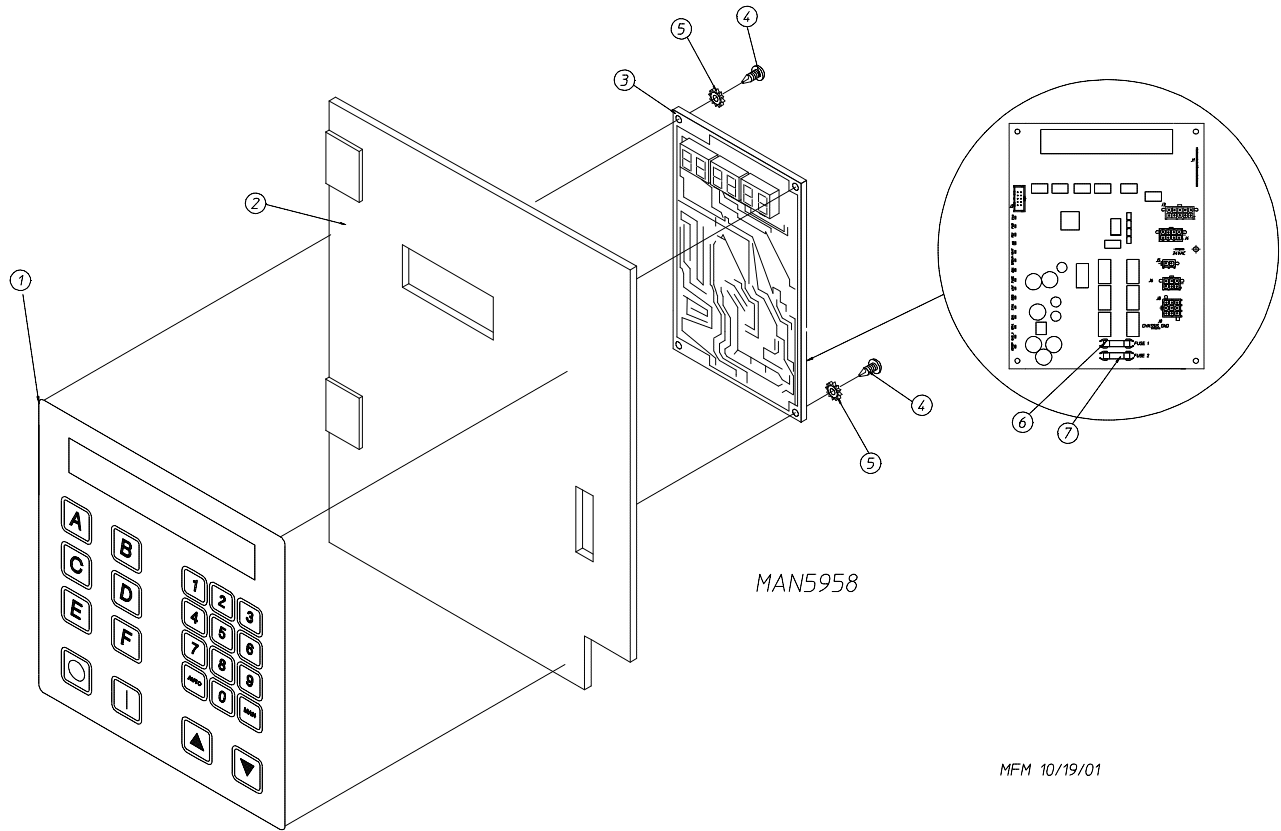

<u>Illus. No.</u>	<u>Part No.</u>	<u>Qty.</u>	<u>Description</u>
1	112571	1	Phase 7 OPL Keyboard
2	850984	1	Phase 7 Microprocessor Controller (computer) Panel ONLY
3	822767	1	Phase 7 OPL Reversing Microprocessor Controller (computer) Control Panel Assembly Complete (includes illus. nos. 1 through 7)
	137247	1	Phase 7 OPL Microprocessor Controller (computer) ONLY
4	150005	2	#6-32 x 3/4" Phillips Round Head Machine Screw
5	153010	2	#6 Star Washer
6	136016	1	5-Amp Fuse
7	136097	1	500-mA Fuse

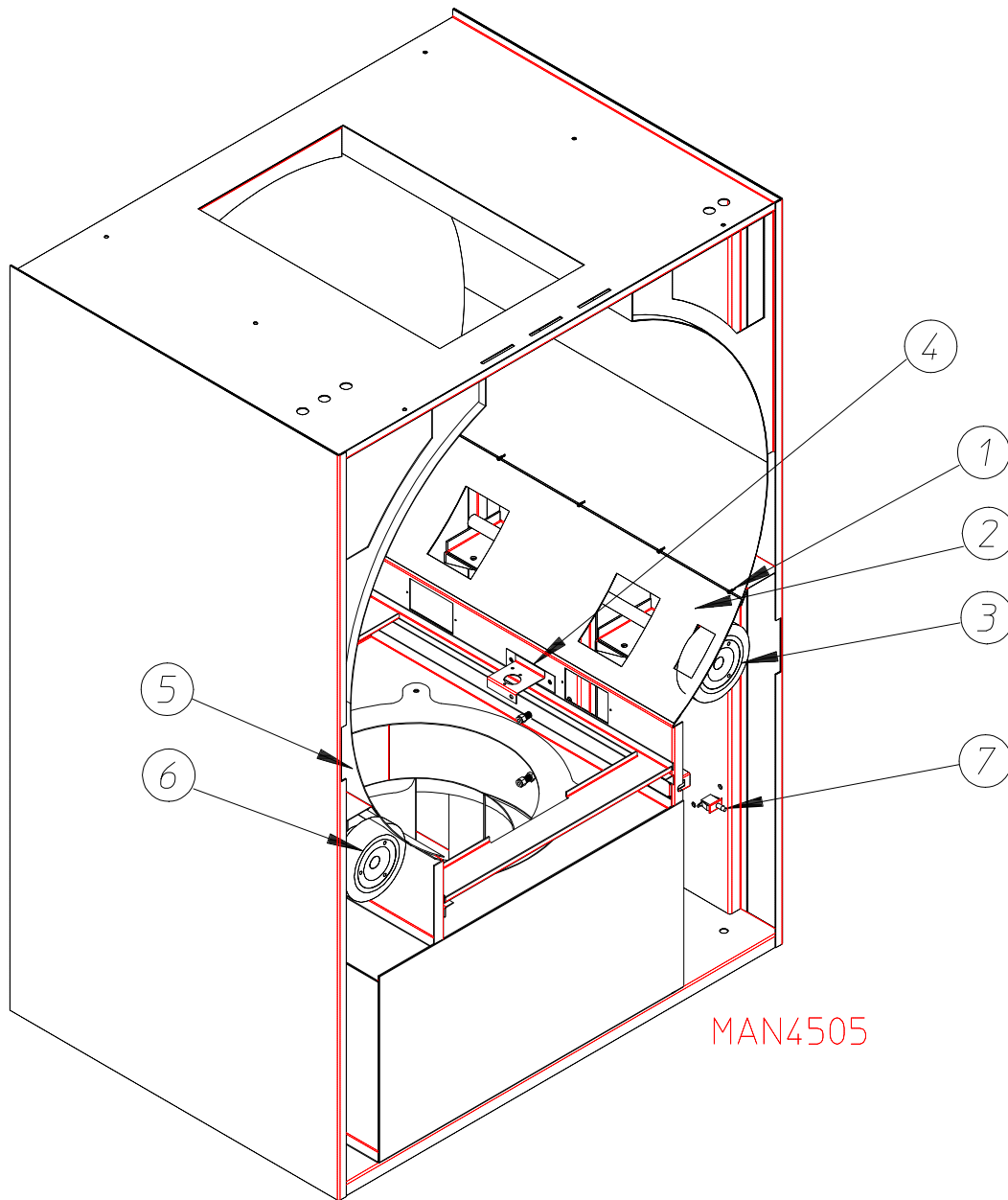

<u>Illus. No.</u>	<u>Part No.</u>	<u>Qty.</u>	<u>Description</u>
1	150309	20	#10-16 x 1/2" Hex Head TEK Crimptite Screw
2	859367	1	Bottom Right Wrapper
3	-----	1	Drive Shaft Assembly (refer to <b>Drive Shaft Assembly</b> on <u>page 13</u> )
4	-----	1	Microprocessor Temperature Sensor Bracket (refer to <b>Microprocessor Temperature Sensor Bracket</b> on <u>page 9</u> )
5	859368	1	Bottom Left Wrapper
6	-----	1	Idler Shaft Assembly (refer to <b>Idler Shaft Assembly</b> on <u>page 14</u> )
7	122116	1	24 VAC Lint Door Switch

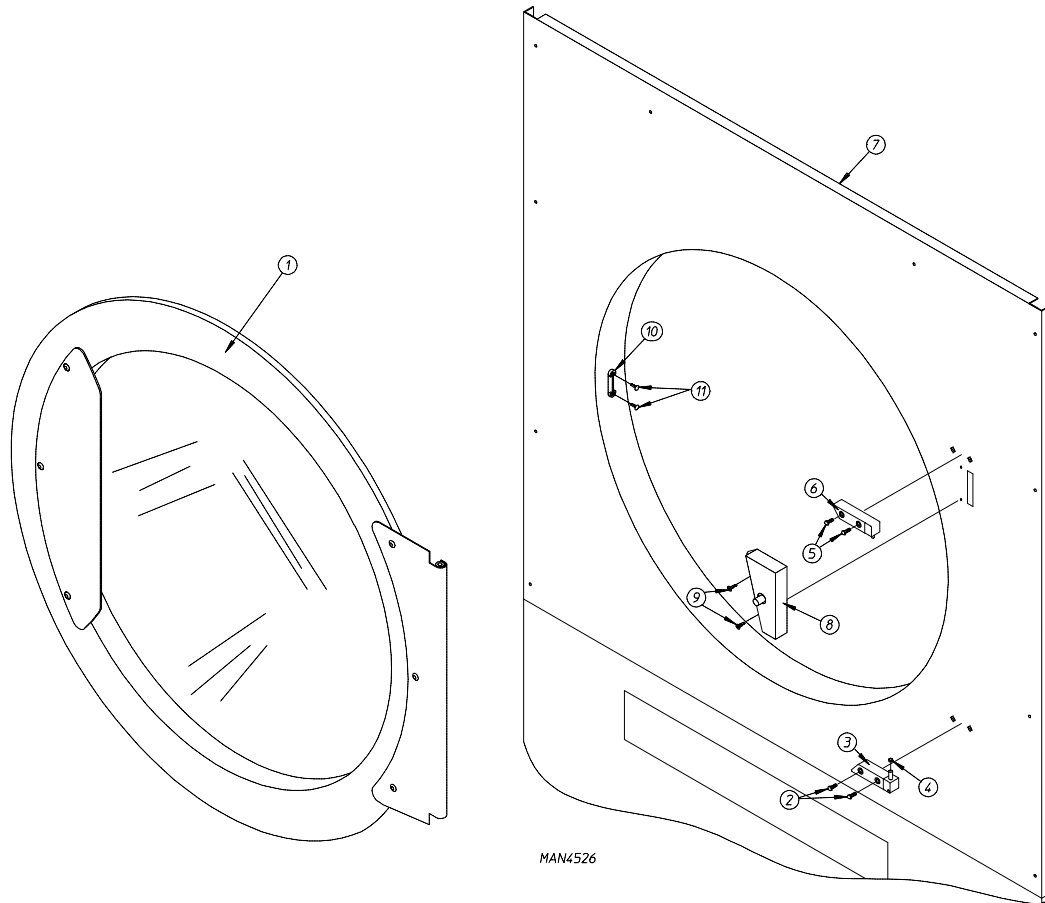

<u>Illus. No.</u>	<u>Part No.</u>	<u>Qty.</u>	<u>Description</u>
1	-----	1	Cold Rolled Steel (CRS) Main Door Assembly (refer to <b>Cold Rolled Steel (CRS) Door Assembly</b> on <a href="#">page 6</a> )
2	150443	2	Socket Cap Screw
3	881441	1	White Bottom Hinge Block
	882283	1	Coral Blue Bottom Hinge Block
4	153031	1	Nylon Washer
5	150443	2	Socket Cap Screw
6	881440	1	White Top Hinge Block
	882284	1	Coral Blue Top Hinge Block
7	883318	1	White Front Panel Assembly
	883319	1	Coral Blue Front Panel Assembly
	882288	1	White Front Panel Assembly Complete (includes illus. nos. 2 through 11)
	882289	1	Cornflower Blue Front Panel Assembly Complete (includes illus. nos. 2 through 11)
	882290	1	Coral Blue Front Panel Assembly Complete (includes illus. nos. 2 through 11)
8	-----	1	Main Door Switch Assembly (refer to <b>Main Door Switch Assembly</b> on <a href="#">page 7</a> )
9	150201	2	#10-32 x 1/4" Phillips Pan Head Tap Screw
10	170330	1	Friction Door Latch
11	154215	2	5/32 x 1/4" Rivet

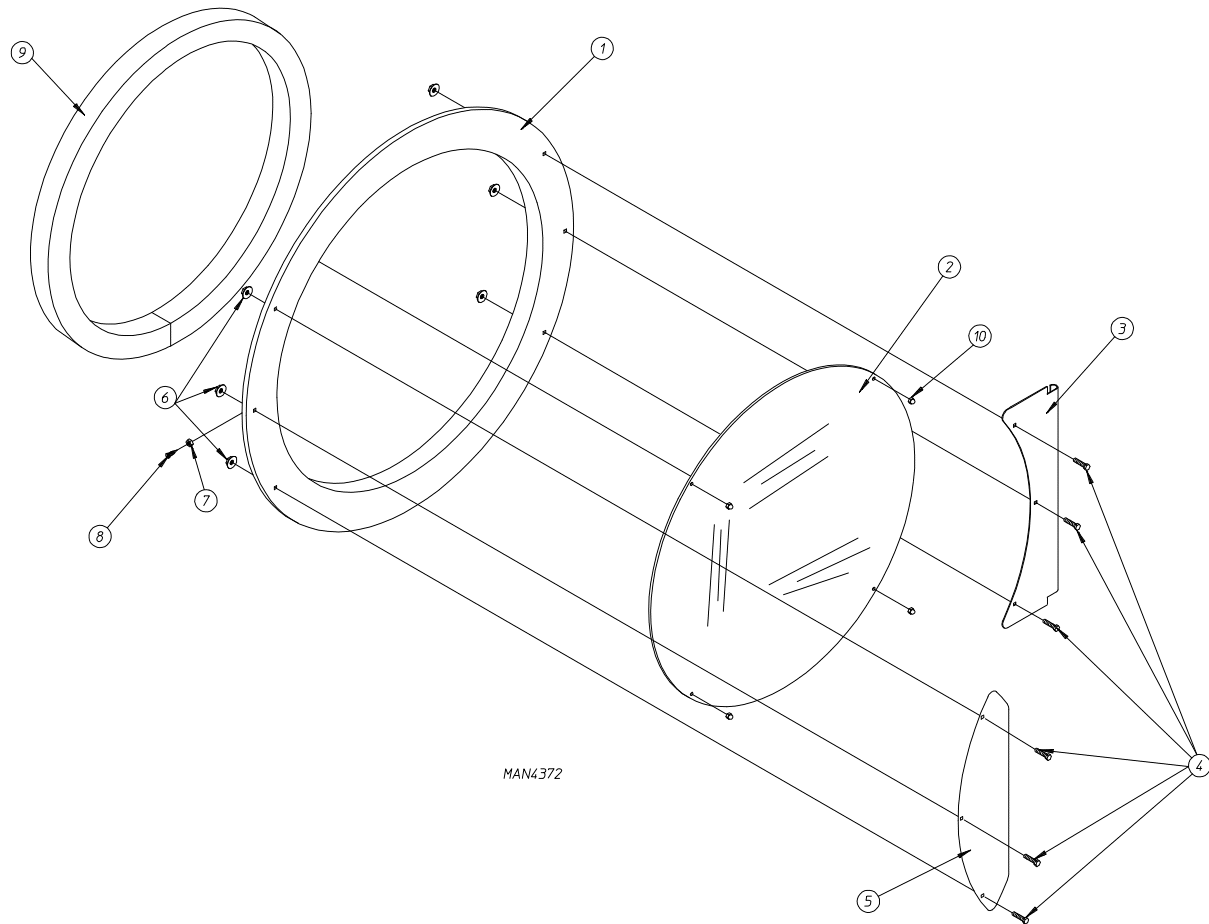

<u>Illus. No.</u>	<u>Part No.</u>	<u>Qty.</u>	<u>Description</u>
1	881689	1	White Cold Rolled Steel (CRS) Main Door Assembly (includes illus. nos. 2 through 10)
	882292	1	Coral Blue Cold Rolled Steel (CRS) Main Door Assembly (includes illus. nos. 2 through 10)
	881684	1	White Cold Rolled Steel (CRS) Main Door Ring
	882305	1	Coral Blue Cold Rolled Steel (CRS) Main Door Ring
2	102214	1	30" Door Glass
	170730	1	Door Glass Adhesive (10.3 oz. cartridge)
3	881685	1	White Main Door Hinge
	882296	1	Coral Blue Main Door Hinge
4	881740	6	1/4-20 x 5/8" White Carriage Bolt
	882311	6	1/4-20 x 5/8" Cornflower Blue Carriage Bolt
	882294	6	1/4-20 x 5/8" Coral Blue Carriage Bolt
5	881688	1	White Main Door Handle
	882295	1	Coral Blue Main Door Handle
6	881806	6	1/4-20 White Free Spin Wash Nut
	882293	6	1/4-20 Coral Blue Free Spin Wash Nut
7	152008	1	#10-32 Hex Nut
8	150120	1	Door Latch Screw
9	882411	1	Door Gasket
10	151012	4	#10-32 White Nylon Acorn Nut



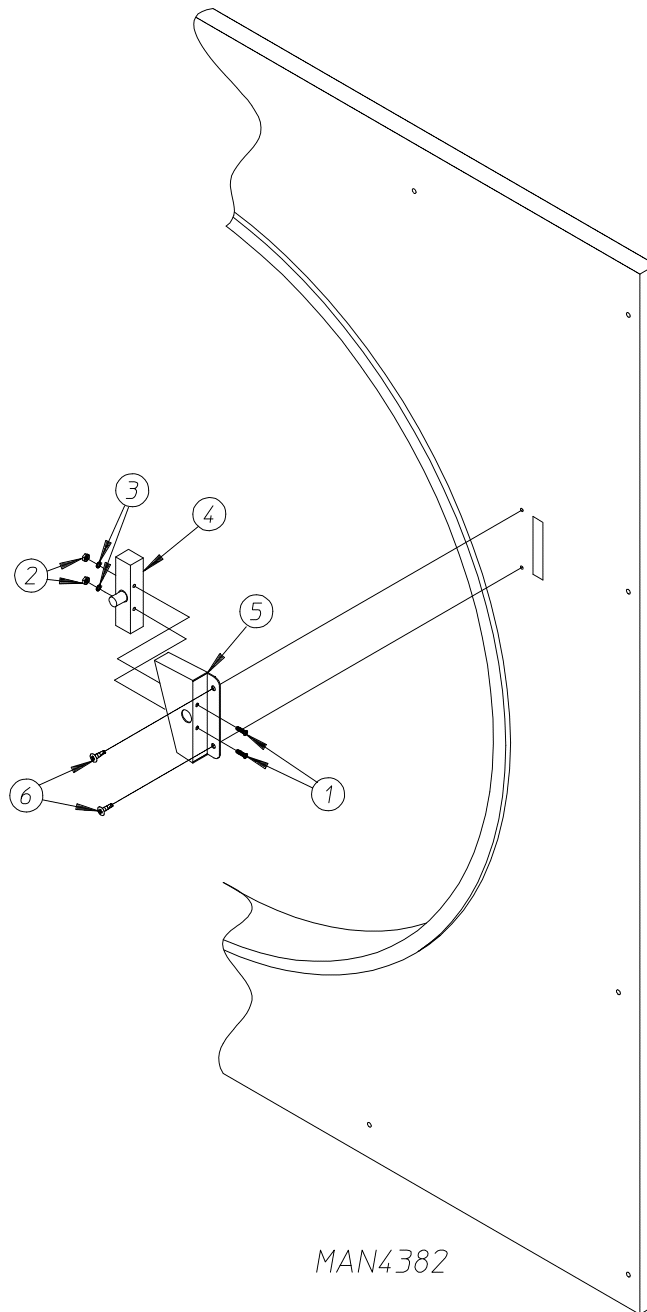

<u>Illus. No.</u>	<u>Part No.</u>	<u>Qty.</u>	<u>Description</u>
1	150006	2	#6-32 x 7/8" Phillips Pan Head Machine Screw
2	152013	2	#6-32 Hex Nut
3	153010	2	#6 Star Washer
4	137005	1	Door Switch
5	881702	1	White Main Door Switch Housing Assembly (includes illus. nos. 1 through 5)
	882298	1	Coral Blue Main Door Switch Housing Assembly (includes illus. nos. 1 through 5)
	881687	1	White Main Door Switch Housing ONLY
	882291	1	Coral Blue Main Door Switch Housing ONLY
6	150201	2	#10-32 x 1/4" Phillips Pan Head Tap Screw

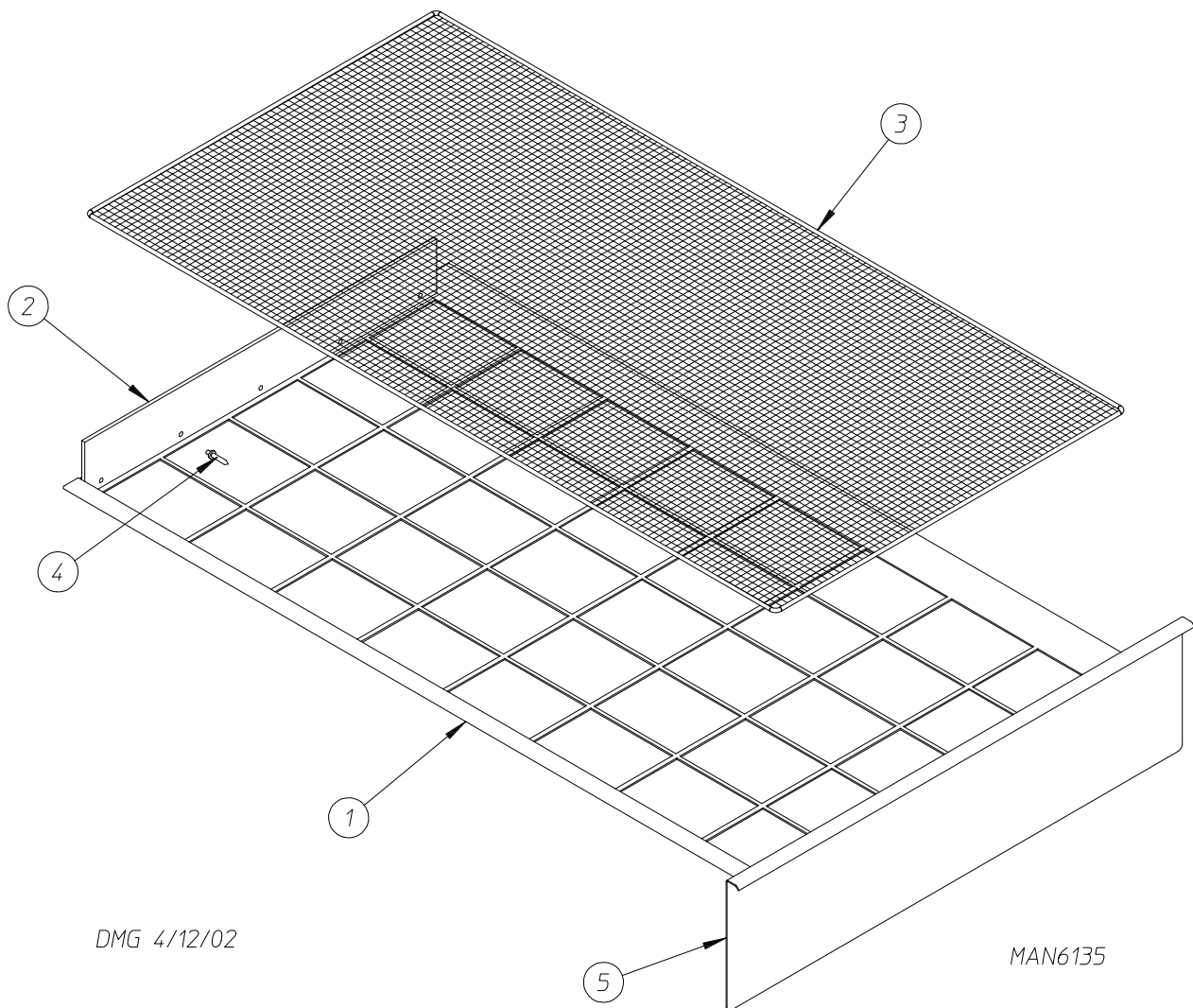

<u>Illus. No.</u>	<u>Part No.</u>	<u>Qty.</u>	<u>Description</u>
1	882299	1	White Lint Drawer Assembly (includes illus. nos. 1 and 2)
	882301	1	Coral Blue Lint Drawer Assembly (includes illus. nos. 1 and 2)
2	115902	1	Lint Basket Felt
3	108227	1	Cloth Lint Screen Assembly
	816100	1	Stainless Steel Lint Screen Assembly
4	154215	5	5/32 x 1/4" Rivet
5	117607	6'	1/4" x 3/8" Poron Foam

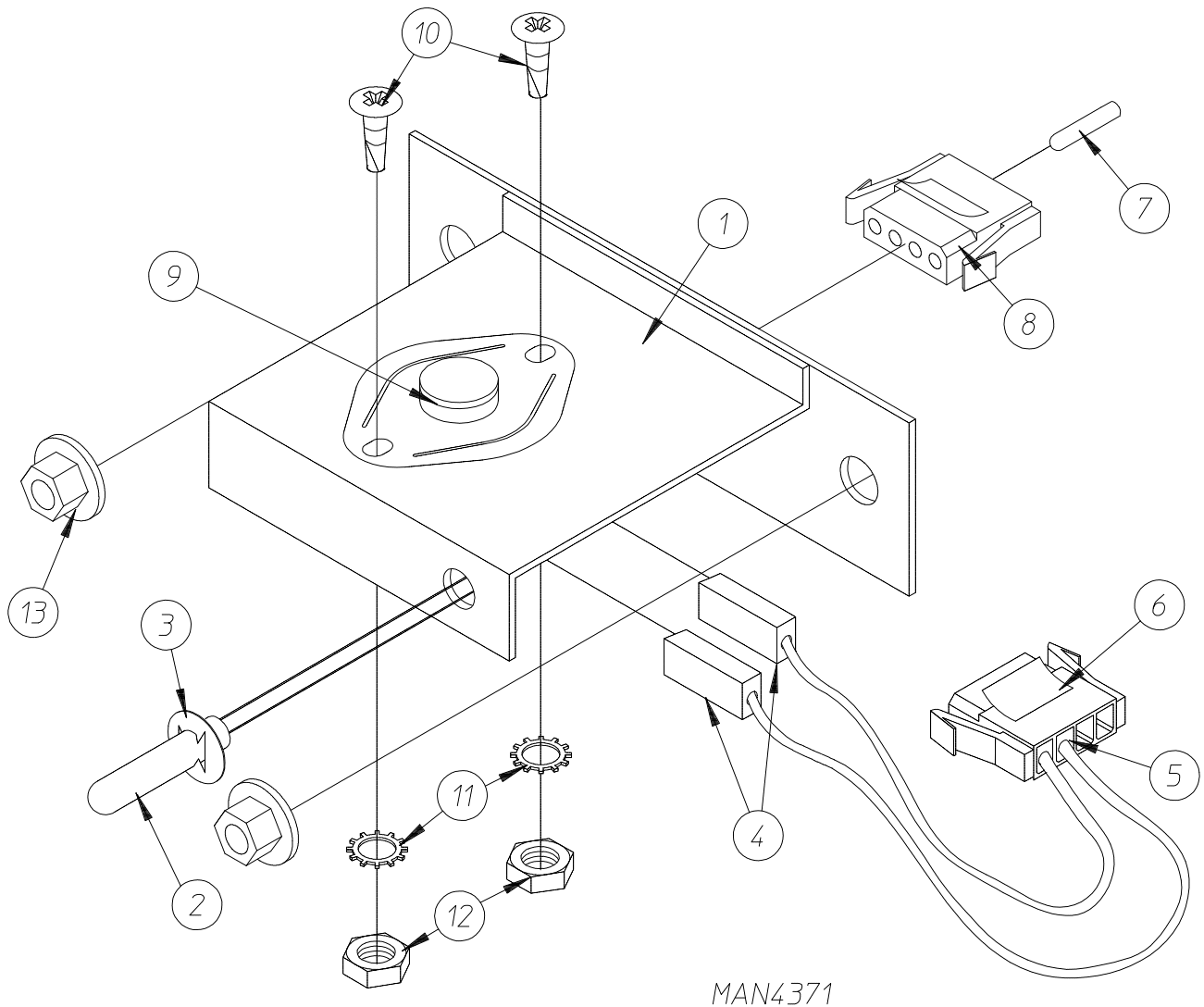

<u>Illus. No.</u>	<u>Part No.</u>	<u>Qty.</u>	<u>Description</u>
1	859372	1	Microprocessor Temperature Sensor Bracket Complete (includes illus. nos. 1 through 13)
	881089	1	Microprocessor Temperature Sensor Bracket ONLY
2	880252	1	4" Temperature Sensor
3	154007	2	1/4" Push On Fastener
4	121028	2	1/4" Terminal
5	122701	4	Socket Terminal ONLY
6	122605	1	4-Position Female Connector
7	122700	4	Pin Terminal ONLY
8	122604	1	4-Position Male Connector
9	130302	1	225° Manual Reset Thermostat
10	150005	2	#6-32 x 1/4" Phillips Round Head Machine Screw
11	153010	2	#6 Star Washer
12	152013	2	#6-32 Hex Nut
13	152014	2	1/4-20 Free Spin Wash Nut

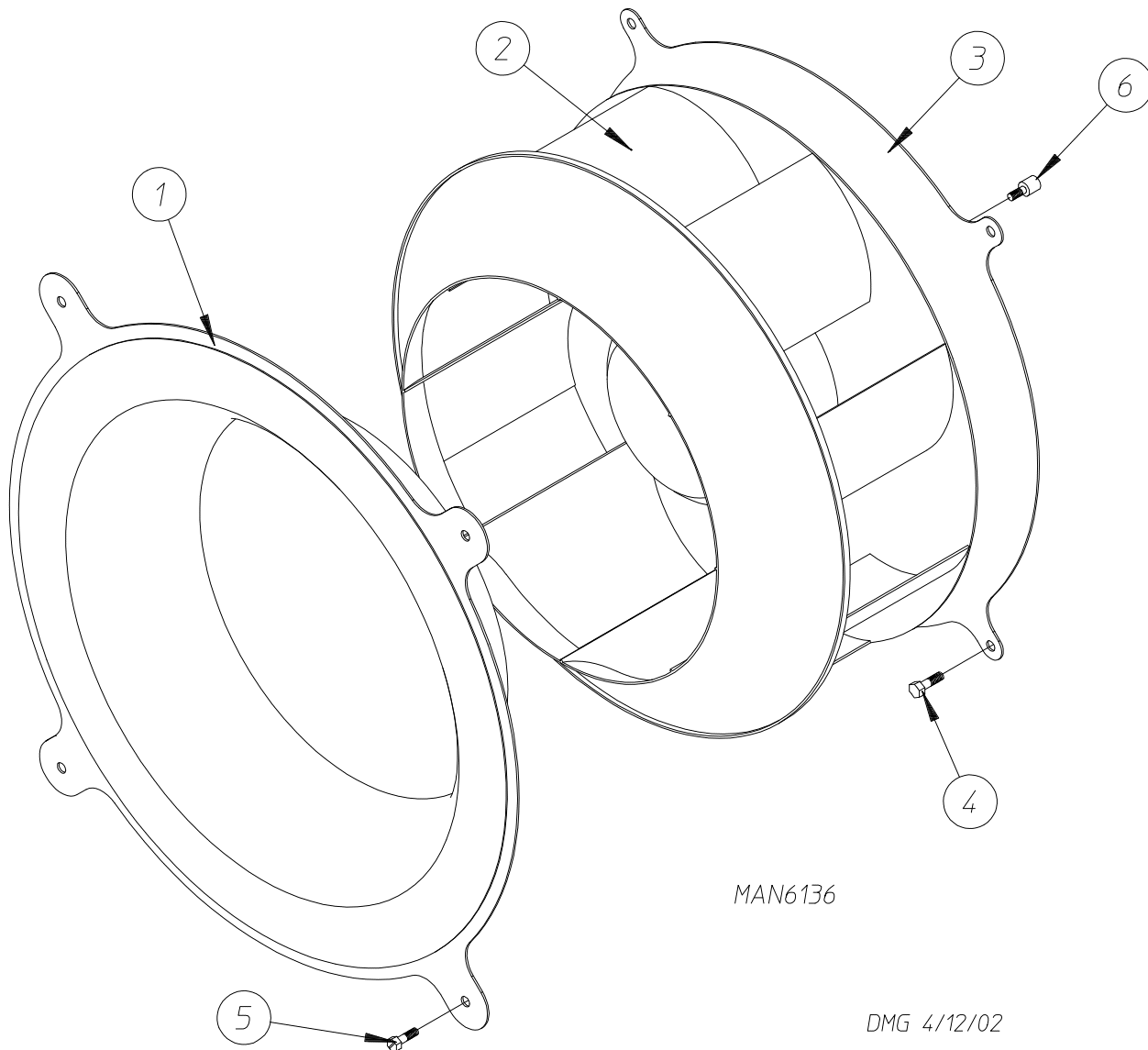

<u>Illus. No.</u>	<u>Part No.</u>	<u>Qty.</u>	<u>Description</u>
1	859364	1	Coop Cone
2	100622	1	Motorized Impellor (fan/blower) 230V 3 $\phi$ 60 Hz
	100619	1	Motorized Impellor (fan/blower) 230/400V 3 $\phi$ 50 Hz, 460/480V 3 $\phi$ 60 Hz
	100617	1	Motorized Impellor (fan/blower) 208V 3 $\phi$ 60 Hz
	859361	1	Motorized Impellor Assembly 230V 3 $\phi$ 60 Hz (includes illus. nos. 1, 2, 3, and 6)
	816086	1	Motorized Impellor Assembly 230/400V 3 $\phi$ 50 Hz, 460/480V 3 $\phi$ 60 Hz (includes illus. nos. 1, 2, 3, and 6)
	859363	1	Motorized Impellor Assembly 208V 3 $\phi$ 60 Hz (includes illus. nos. 1, 2, 3, and 6)
3	390254	1	Motor Plate
4	150504	4	5/16-18 x 1" Hex Head Bolt
5	150512	4	1/4-20 x 1/2" Hex Head Machine Bolt
6	154335	8	M10 x 16 Metric Tap Bolt

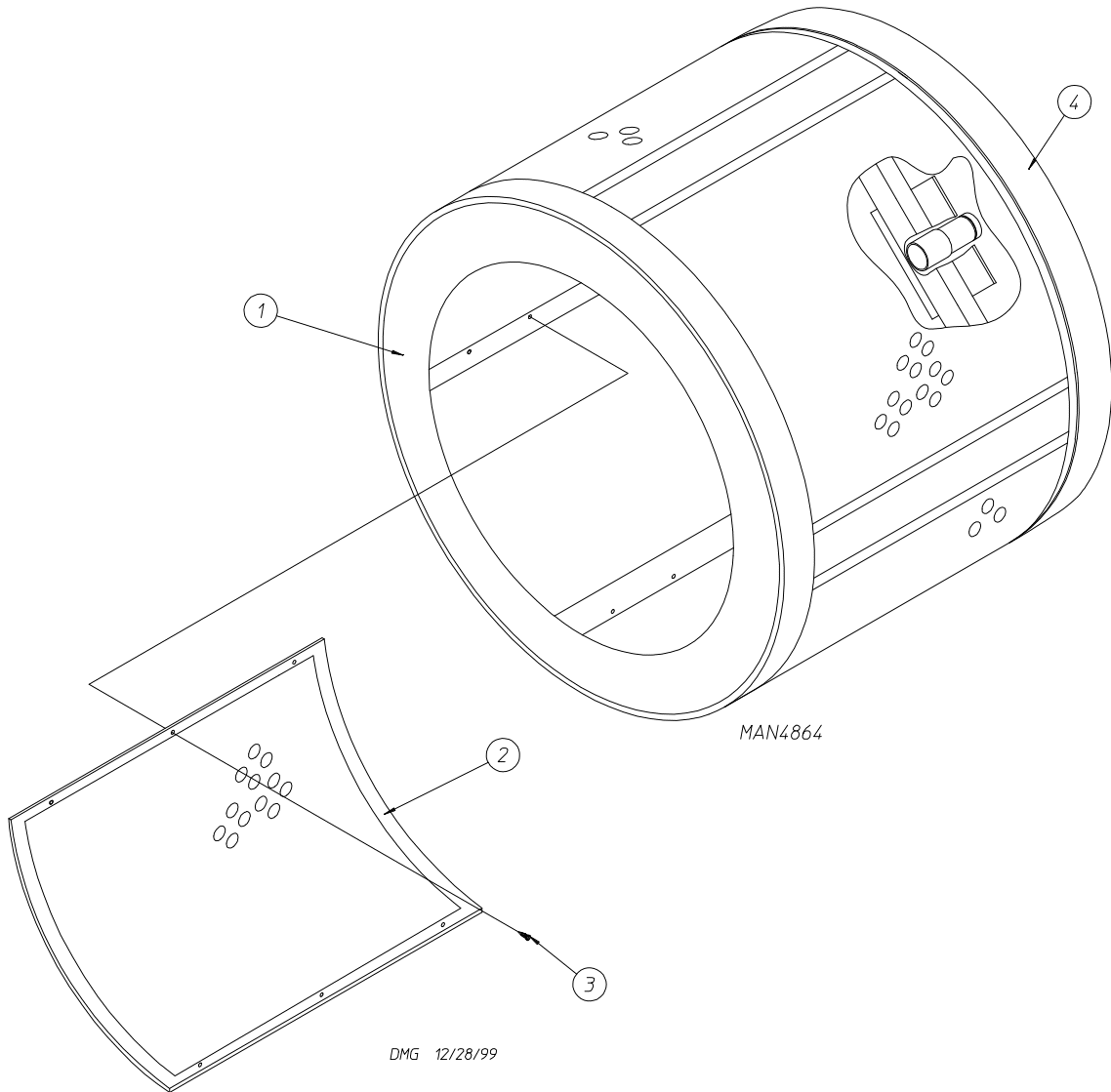

<u>Illus. No.</u>	<u>Part No.</u>	<u>Qty.</u>	<u>Description</u>
1	819048	1	Basket (tumbler) and Support Complete (includes illus. nos. 1 through 3)
2	390704	4	Basket (tumbler) Side
3	150118	48	1/4-20 x 1/4" Stainless Steel Phillips Pan Head Screw
4	116006	1	Felt Collar 139-3/8" x 2-1/2" x 1/8"
--	401010	1	3M #847 Construction Mastic

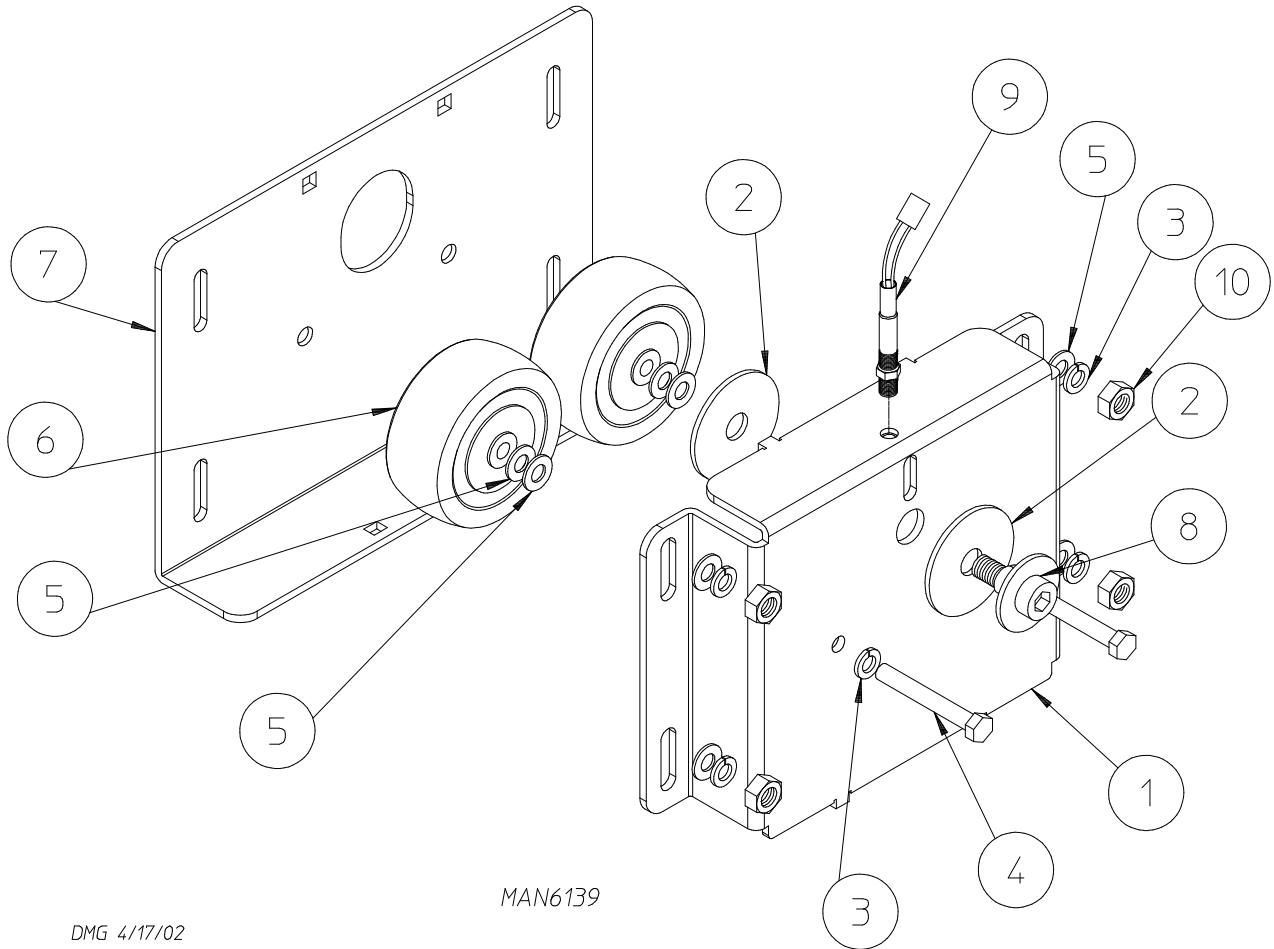

MAN6139

DMG 4/17/02

<u>Illus. No.</u>	<u>Part No.</u>	<u>Qty.</u>	<u>Description</u>
1	819064	1	Basket (tumbler) Shaft Support Assembly Complete (includes illus. nos. 1 through 8)
	835339	1	Basket (tumbler) Shaft Support Bracket
2	102394	2	Basket (tumbler) Friction Pad
3	153005	6	3/8" Lock Washer
4	150619	2	3/8-16 x 1" Tap Bolt
5	153004	8	3/8" Flat Washer
6	180018	4	4" x 1-1/2" Hi-Impact Wheel
7	819046	1	Basket (tumbler) Adjustment Plate
8	819065	1	Basket (tumbler) Shoulder Screw
9	822735	1	Phase 7 Rotational Sensor Assembly
10	152005	4	3/8-16 Hex Nut

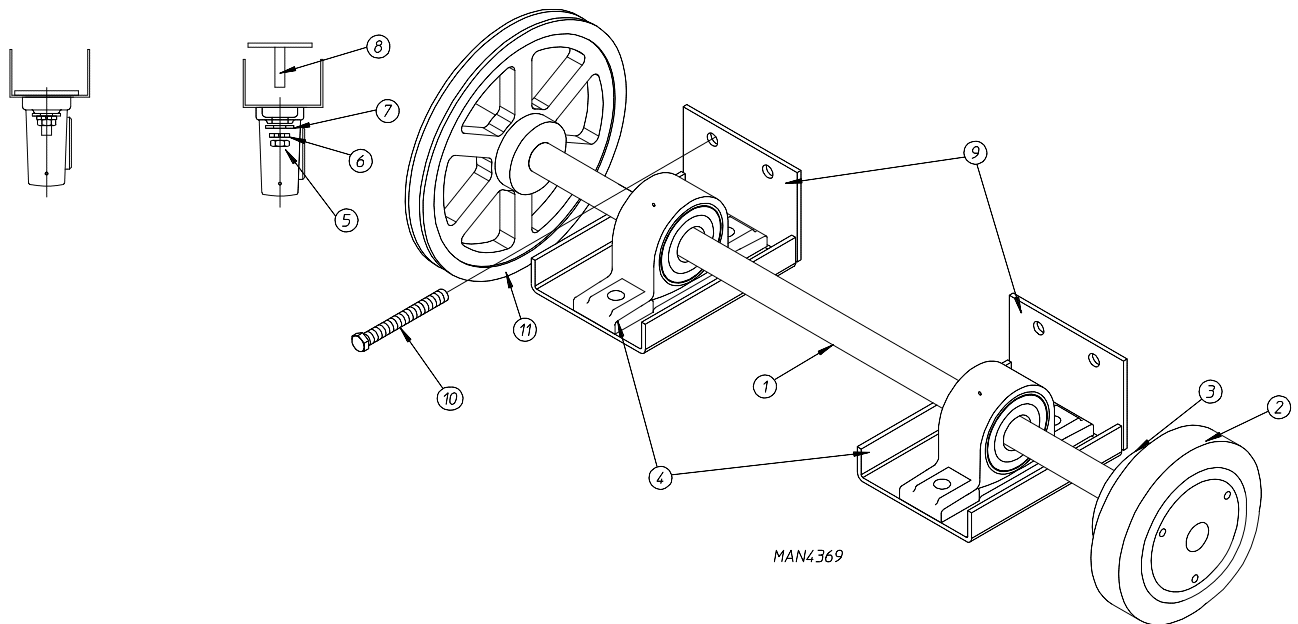

<u>Illus. No.</u>	<u>Part No.</u>	<u>Qty.</u>	<u>Description</u>
1	390641	1	Drive Shaft ONLY
	816061	1	Drive Shaft Assembly (includes illus. nos. 1 through 11)
2	180033	1	6-1/4" Drive Wheel and Hub
3	180038	1	1" Taper Lock
4	880205	2	1" Pillow Block Bearing
5	152004	4	5/16-18 Hex Nut
6	153002	4	5/16" Lock Washer
7	153001	4	5/16" Flat Washer
8	859008	2	Bearing Bolt Plate Assembly
9	816108	2	Bearing Pad
10	150613	4	5/16-18 x 4" Tap Bolt
11	101209	1	9" Pulley

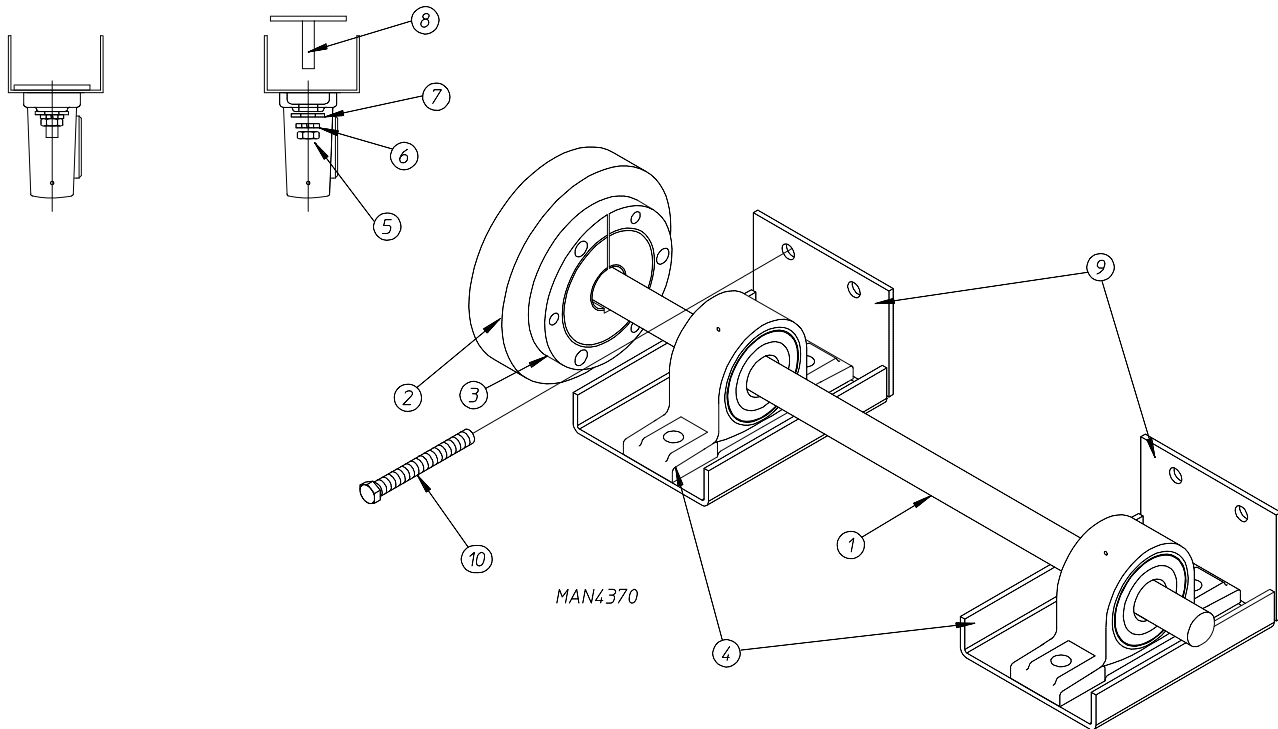

<u>Illus. No.</u>	<u>Part No.</u>	<u>Qty.</u>	<u>Description</u>
1	390642	1	Idler Shaft ONLY
	816062	1	Idler Shaft Assembly (includes illus. nos. 1 through 10)
2	180033	1	6-1/4" Drive Wheel and Hub
3	180038	1	1" Taper Lock
4	880205	2	1" Pillow Block Bearing
5	152004	4	5/16-18 Hex Nut
6	153002	4	5/16" Lock Washer
7	153001	4	5/16" Flat Washer
8	816108	2	Bearing Bolt Plate Assembly
9	859327	2	Bearing Pad
10	150613	4	5/16-18 x 4" Tap Bolt



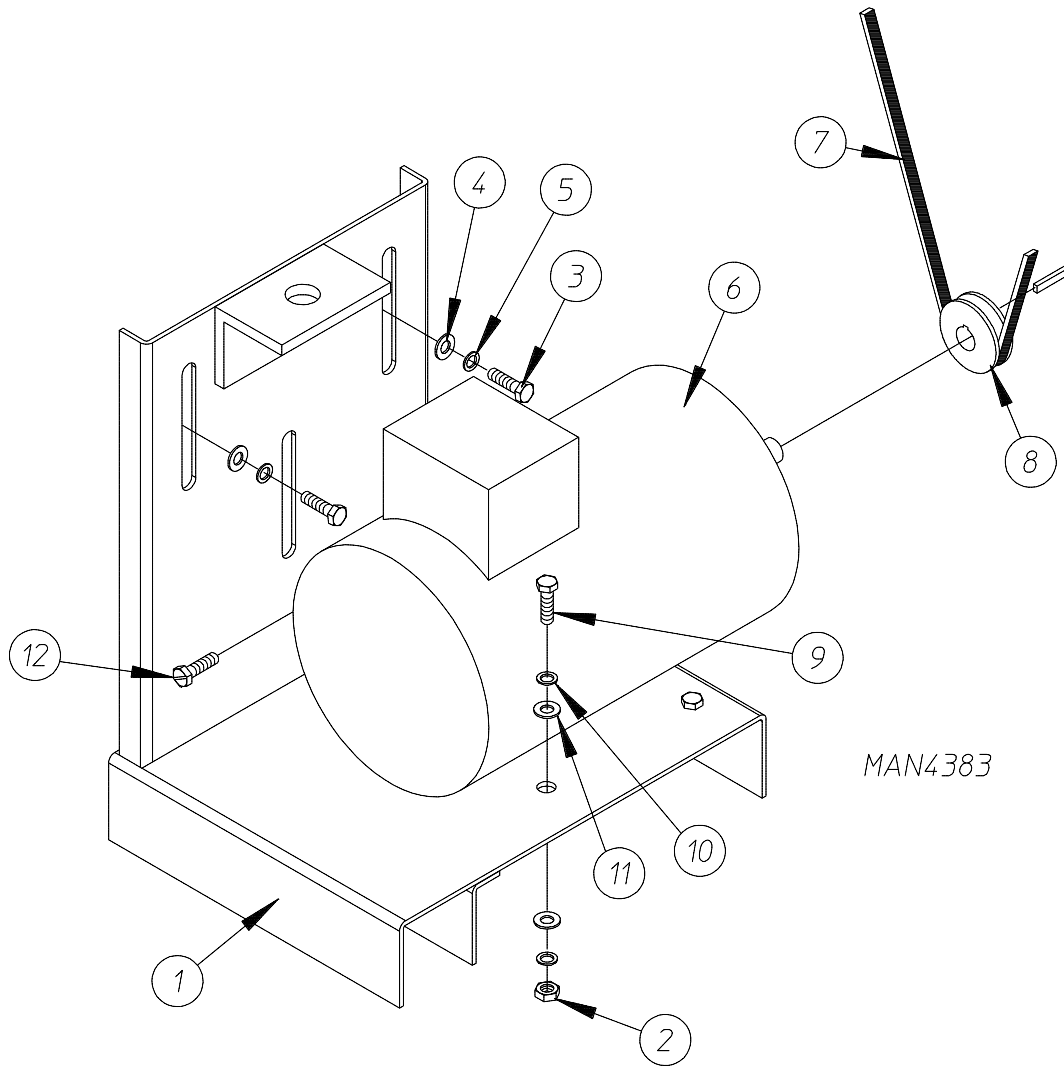

MAN4383

<u>Illus. No.</u>	<u>Part No.</u>	<u>Qty.</u>	<u>Description</u>
1	859332	1	Motor Mount
2	152004	4	5/16" Hex Nut
3	150501	2	5/16-18 x 3/4" Hex Bolt
4	153001	3	5/16" Flat Washer
5	153002	3	5/16" Lock Washer
6	816060	1	Drive Motor Assembly (60 Hz) (includes illus. nos. 1 through 12)
	181029	1	1 HP 200-230/460V 3 $\phi$ 60 Hz Drive Motor
	816088	1	Drive Motor Assembly (50 Hz) (includes illus. nos. 1 through 12)
	181034	1	1 HP 200-230/460V 3 $\phi$ 50 Hz Drive Motor
7	100174	1	AX53 Cogged Belt
8	101132	1	2.0 O.D. x 5/8" Machine MA Sheave 60 Hz
	101130	1	2.5 x 5/8" Bore MA Sheave 50 Hz
9	150501	4	5/16-18 x 3/4" Hex Bolt
10	153002	8	5/16" Lock Washer
11	153001	8	5/16" Flat Washer
12	150501	1	5/16-18 x 3/4" Hex Bolt

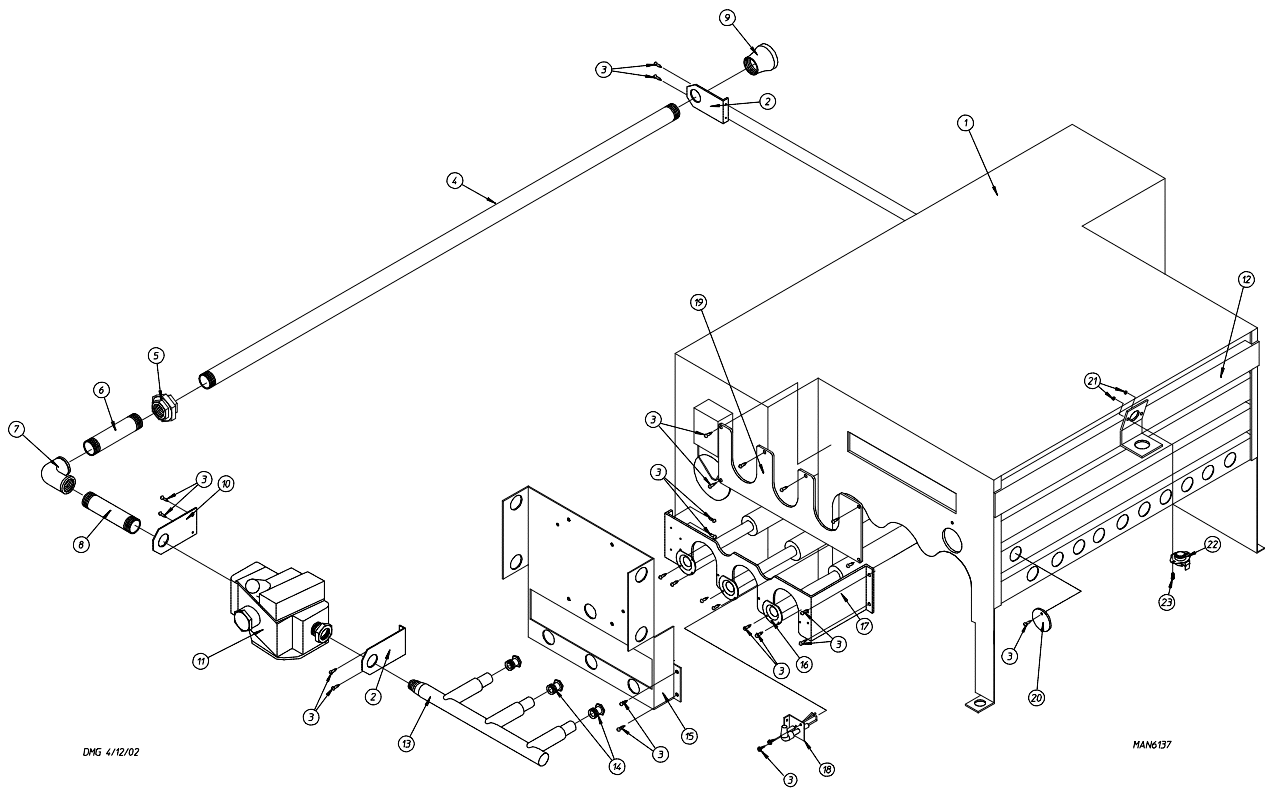

---

<u>Illus. No.</u>	<u>Part No.</u>	<u>Qty.</u>	<u>Description</u>
1	816110	1	Burner Box ONLY
2	331291	2	Gas Valve Pipe Bracket
3	150309	27	#10-16 x 1/2" Hex Head TEK Crimptite Screw
4	142821	1	3/4" x 36" Nipple
5	142601	1	3/4" Union
6	142710	1	3/4" x 4" Nipple
7	142504	1	3/4" x 90° Elbow
8	142734	1	3/4" x 5-1/2" Nipple
9	142753	1	1-1/4" to 3/4" Reducing Coupling
10	354030	1	Pipe Bracket (flat)
11	140026	1	Direct Spark Ignition (DSI) 3/4" 24 VAC Redundant Gas Valve (natural gas)
12	821457	1	Hi-Limit Bracket
13	141219	1	3-Port Manifold
14	140839	3	#2 Burner Orifice (natural gas)
15	335031	1	Direct Spark Ignition (DSI) Mount Manifold Rest
16	141136	3	Uginox Burner Tube
17	390709	1	Burner Tube Support ONLY
18	128914	1	Ignitor/Flame-Probe Assembly
19	390708	1	Direct Spark Ignition (DSI) Burner Box Cover Plate ONLY
20	331290	1	Ignitor/Flame-Probe Sight Hole Disc ONLY
21	151000	2	#6-32 Pal Nut
22	130201	1	330° Manual Reset Hi-Limit ONLY
23	150001	2	#6-32 x 1/2" Right Hand Machine Screw

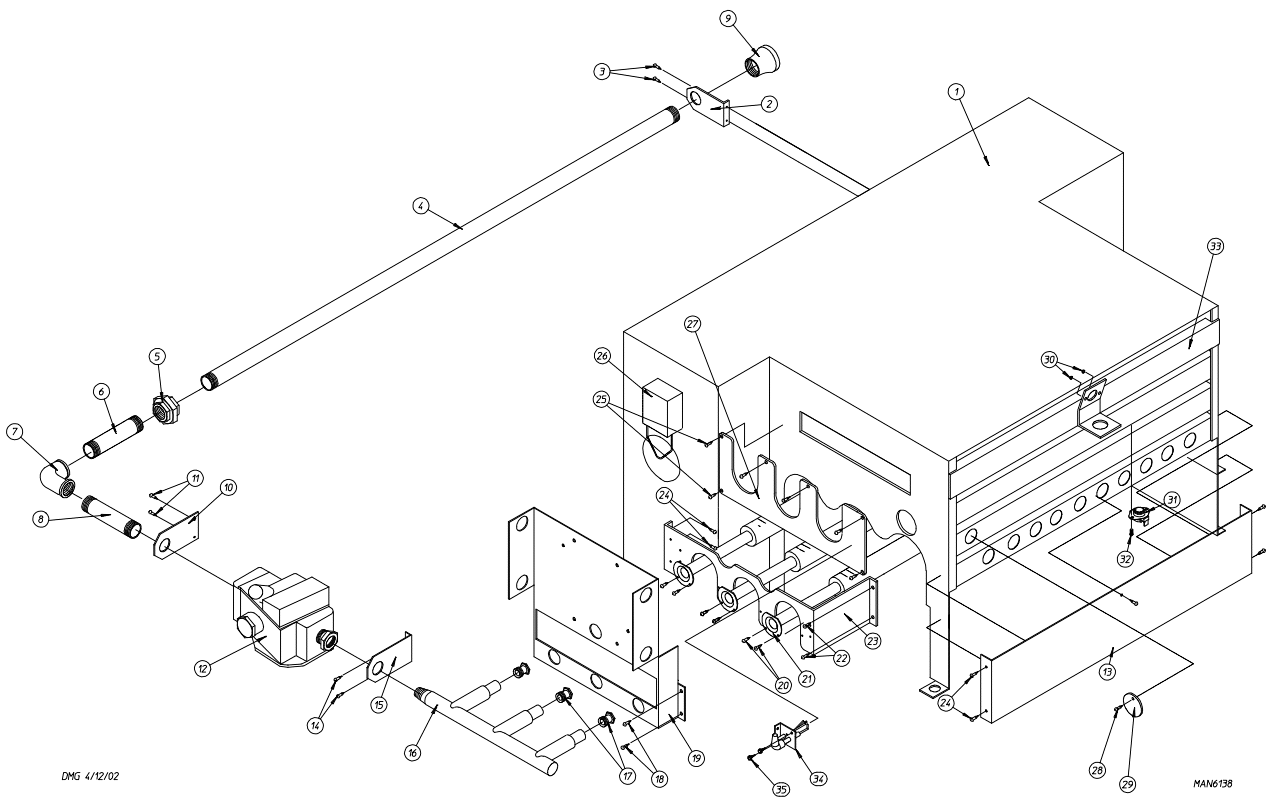

---

<u>Illus. No.</u>	<u>Part No.</u>	<u>Qty.</u>	<u>Description</u>
1	816110	1	Burner Box ONLY
2	331291	1	Pipe Bracket
3	150309	2	#10-16 x 1/2" Phillips Right Hand Crimptite Screw
4	142821	1	3/4" x 36" Nipple
5	142601	1	3/4" Union
6	142710	1	3/4" x 4" Nipple
7	142504	1	3/4" x 90° Elbow
8	142734	1	3/4" x 5-1/2" Nipple
9	142753	1	1-1/4" to 3/4" Reducing Coupling
10	354030	1	Pipe Bracket (flat)
11	150309	2	#10-16 x 1/2" Phillips Right Hand Crimptite Screw
12	140026	1	Direct Spark Ignition (DSI) 3/4" 24 VAC Redundant Gas Valve (natural gas)
	140411	1	Liquid Propane (L.P.) Kit
13	332256	1	Liquid Propane (L.P.) Burner Baffle
14	150309	2	#10-16 x 1/2" Phillips Right Hand Crimptite Screw
15	331291	1	Gas Valve Pipe Bracket
16	141219	1	3-Port Manifold
17	140819	3	#30 Burner Orifice (liquid propane [L.P.] gas)
18	150309	4	#10-16 x 1/2" Phillips Right Hand Crimptite Screw
19	335031	1	Direct Spark Ignition (DSI) Mount Manifold Rest
20	150309	6	#10-16 x 1/2" Phillips Right Hand Crimptite Screw
21	141136	3	Uginox Burner Tube
22	150309	7	#10-16 x 1/2" Phillips Right Hand Crimptite Screw
23	390709	1	Burner Tube Support ONLY
24	150309	2	#10-16 x 1/2" Phillips Right Hand Crimptite Screw
25	150309	6	#10-16 x 1/2" Phillips Right Hand Crimptite Screw
26	802801	1	Sail Switch Assembly
27	390708	1	Burner Box Cover Plate ONLY
28	150309	1	#10-16 x 1/2" Phillips Right Hand Crimptite Screw
29	331290	1	Ignitor/Flame-Probe Sight Hole Disc ONLY
30	151000	2	#6-32 Pal Nut
31	130201	1	330° Manual Reset Hi-Limit ONLY
32	150001	2	#6-32 x 1/2" Right Hand Machine Screw
33	821457	1	Hi-Limit Bracket
34	128914	1	Ignitor/Flame-Probe Assembly
35	150309	1	#10-16 x 1/2" Phillips Right Hand Crimptite Screw

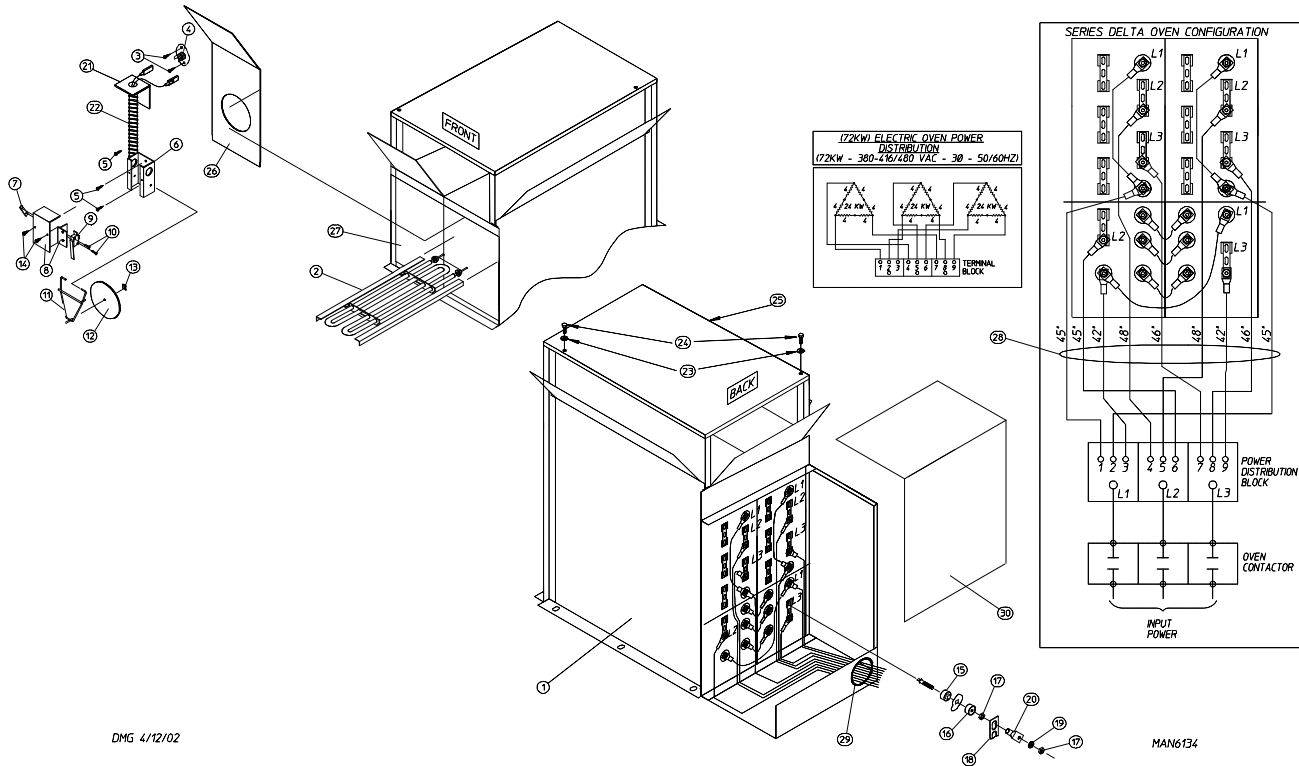

DMG 4/12/02

MAN6134

Illus. No.	Part No.	Qty.	Description
1	816103	1	Electric Oven Box ONLY
2	120011	18	4 Kw/240V Open Coil Element
3	150301	2	#8-18 x 7/16" Phillips Pan Head TEK Screw
4	130400	1	290° Hi-Limit ONLY
5	150309	4	#10-16 x 1/2" Hex Head TEK Crimptite Screw
6	319200	1	Sail Switch Box
7	154004	1	Twin Speed Nut
8	802799	1	Sail Switch Box Cover
9	122200	1	Sail Switch ONLY
10	150303	2	#4 x 3/4" Pan Head "A" Machine Screw
11	105500	1	Sail Switch Actuator Rod
12	319202	1	Sail Switch Damper (flat)
13	154002	1	1/8" Push On Fastener
14	150309	28	#10-16 x 1/2" Hex Head TEK Crimptite Screw
15	120081	36	Internal Ceramic Insulator
16	120080	36	External Ceramic Insulator
17	152008	72	#10-32 Hex Nut
18	121011	3'	Bus Bar
19	153009	36	#10 Star Washer
20	121032	36	#8 Rocktherm Connector
21	353222	1	Pipe Bracket
22	815707	1	Hi-Limit and Sail Switch Harness
23	153007	2	1/4" Lock Washer
24	150512	2	1/4-20 x 1/2" Long Bolt
25	819961	1	Burner Cover Assembly
26	321503	1	Right Front Oven Panel
27	321502	1	Left Front Oven Panel
28	815710	1	#8 Oven Assembly Wiring
29	156001	1	Caterpillar Grommet
30	321501	1	Oven Electrical Cover

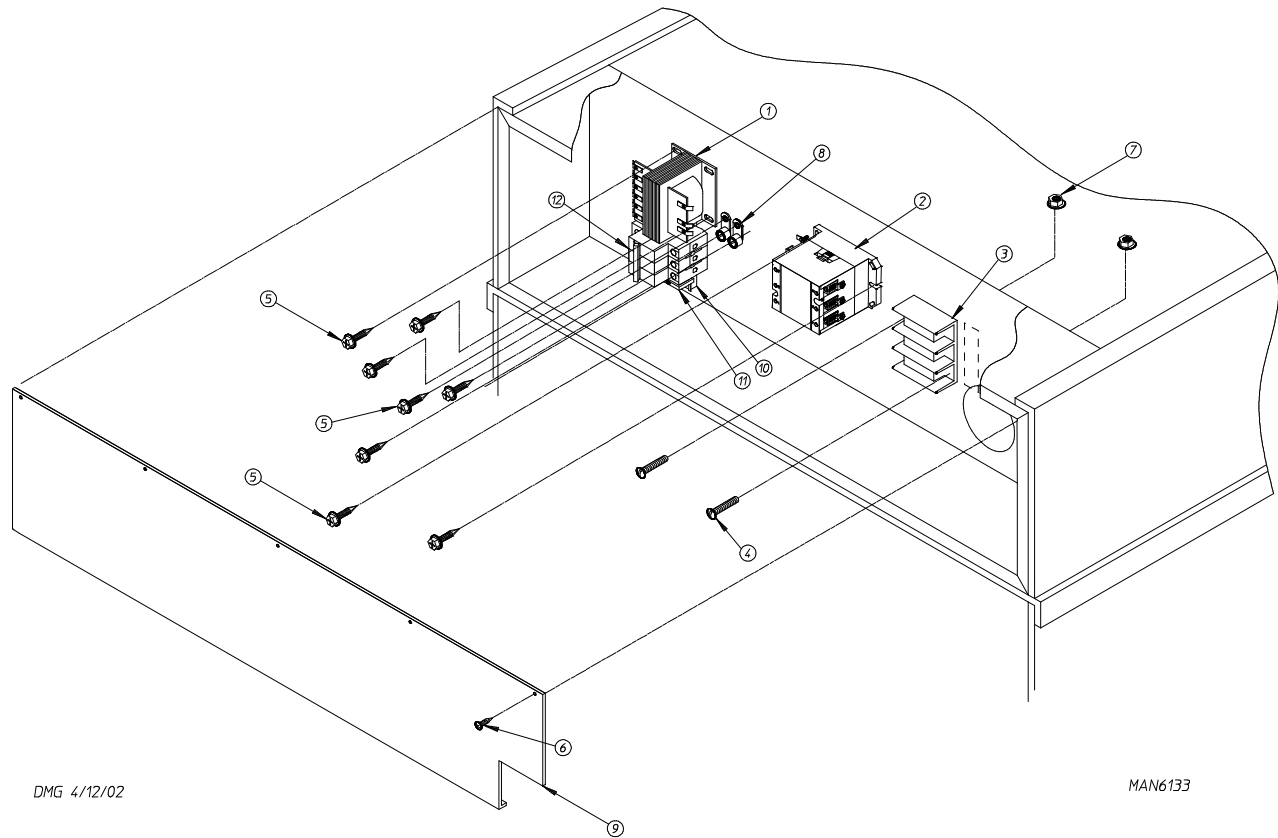

<u>Illus. No.</u>	<u>Part No.</u>	<u>Qty.</u>	<u>Description</u>
1	132004	1	Transformer
2	131358	1	T.S.P.T. 120-Amp - 24 VAC Relay
3	120706	1	Power Distribution Block
4	150521	2	1/4-20 x 2" Carriage Bolt
5	150309	8	#10-16 x 1/2" Hex Head TEK Crimptite Screw
6	150301	5	#8-18 x 7/16" Phillips Pan Head TEK Screw
7	152014	2	1/4-20 Free Spin Washer Nut
8	121010	2	L-170 Terminal Lug
9	310669	1	Box Cover
10	120768	3"	35 x 15mm Din Rail
11	120765	2	Din Rail End Stop
12	135499	1	25-Amp/3 Pole Circuit Breaker
--	842552	*	Oven Relay Box Miscellaneous Wiring

\* Not illustrated.

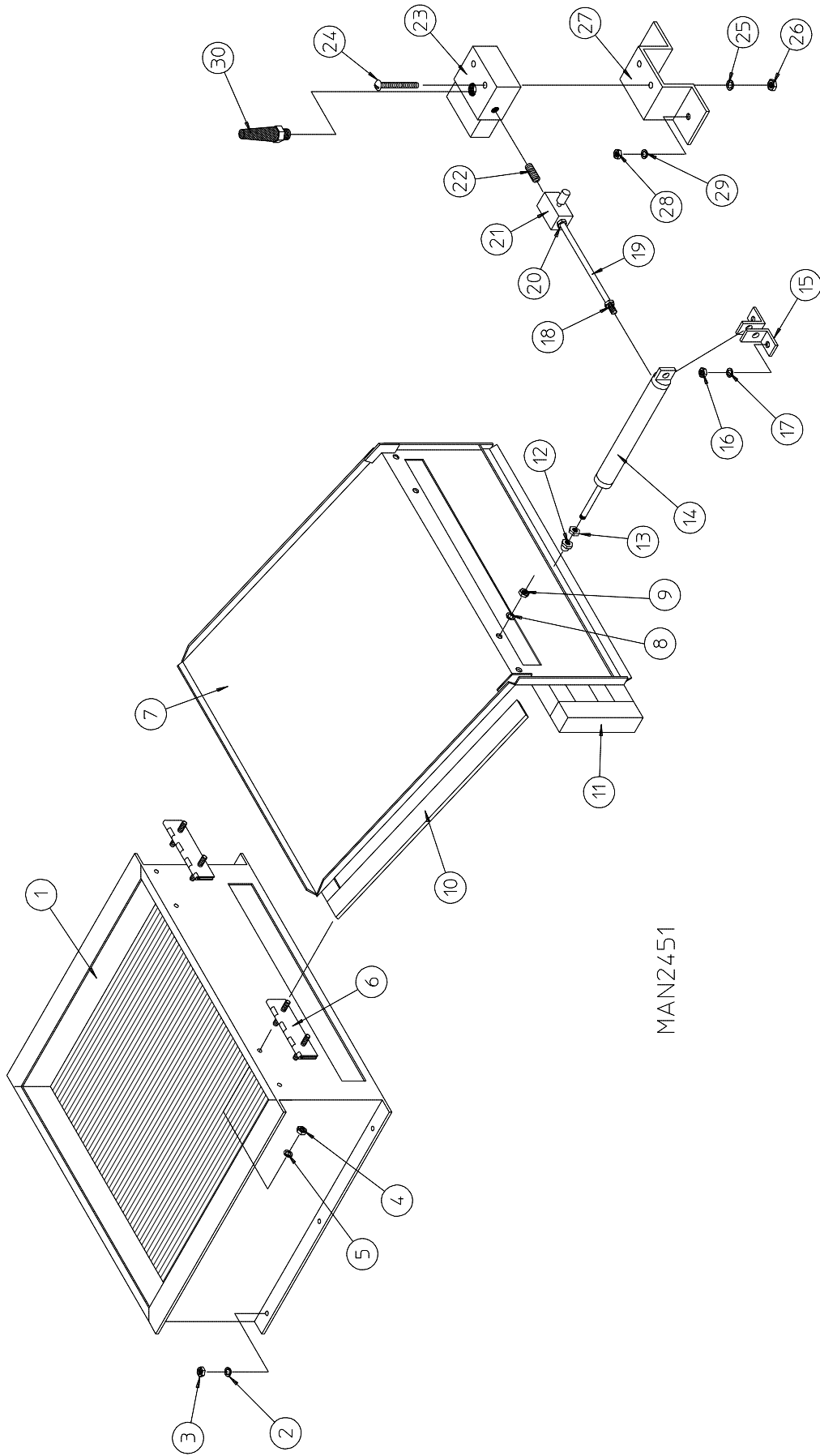

MAN2451



<u>Illus. No.</u>	<u>Part No.</u>	<u>Qty.</u>	<u>Description</u>
1	165012	1	Steam Coil Assembly
	165019	1	Steel Steam Coil Assembly (optional)
2	153002	6	5/16" Lock Washer
3	152004	6	5/16-18 Hex Nut
4	152002	4	1/4-20 Hex Nut
5	153007	4	1/4" Lock Washer
6	820321	2	Steam Damper Hinge Assembly
7	820320	1	Steam Damper Assembly (includes illus. nos. 7, 10, and 11)
8	153007	4	1/4" Lock Washer
9	152002	4	1/4-20 Hex Nut
10	115995	84	Steam Damper Gasket (sold by the inch)
11	102350	1	Gasket (68-12" length)
12	151007	1	7/16-20 Stainless Steel Acorn Nut
13	152007	1	7/16-20 Hex Nut
14	100499	1	1-1/4" Bore x 3" Stroke Piston
15	100500	1	Piston Support Bracket
16	152002	4	1/4-20 Hex Nut
17	153007	4	1/4" Lock Washer
18	100472	1	1/4" x 1/8" Connector
19	143110	1	1/4" Tubing (sold by the foot)
20	100472	1	1/4" x 1/8" Connector
21	100496	1	1/8" Needle Valve
22	143238	1	1/8" Close Nipple
23	100498	1	3-Way Micro Valve 24 VAC
24	150002	2	#6-32 x 1" Round Head Machine Screw
25	153010	2	#6 Star Washer
26	152000	2	#6-32 Hex Nut
27	330987	1	Micro Valve Support Bracket
28	152002	2	1/4-20 Hex Nut
29	153007	2	1/4" Lock Washer
30	100520	1	1/8" N.P.T. Silencer (muffler)

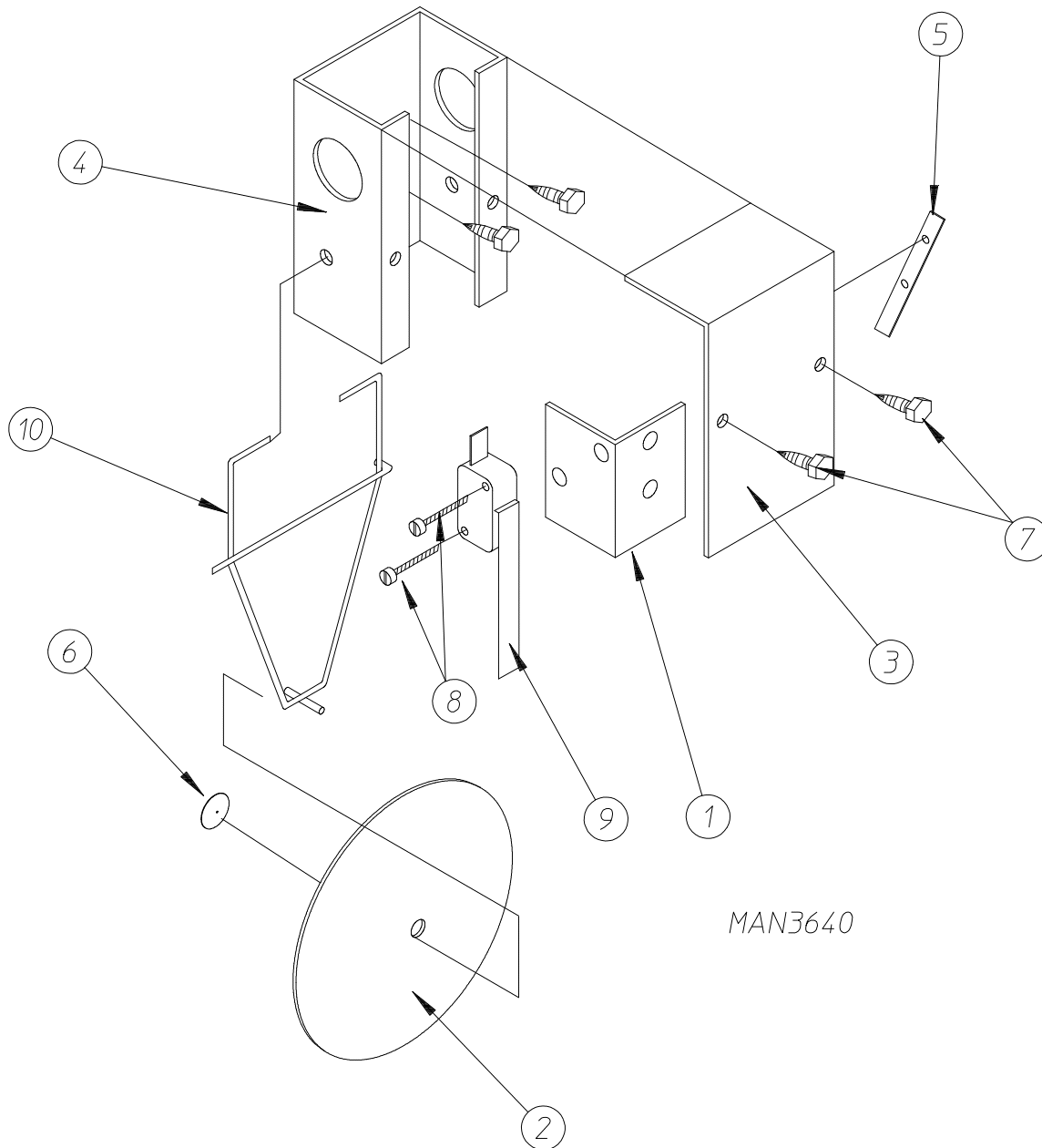

MAN3640

<u>Illus. No.</u>	<u>Part No.</u>	<u>Qty.</u>	<u>Description</u>
1	319203	1	Sail Switch Mounting Bracket
2	319202	1	Sail Switch Damper (flat)
3	319201	1	Sail Switch Box Cover
4	319200	1	Sail Switch Box
5	154004	1	Twin Speed Nut
6	154002	1	1/8" Push On Fastener
7	150309	4	#10-16 x 1/2" Hex Head TEK Crimptite Screw
8	150303	2	#4 x 3/4" Pan Head "A" Machine Screw
9	122200	1	Sail Switch ONLY
	881706	1	Sail Switch Box Assembly Complete (includes illus. nos. 1 through 10)
10	105500	1	Sail Switch Actuator Rod

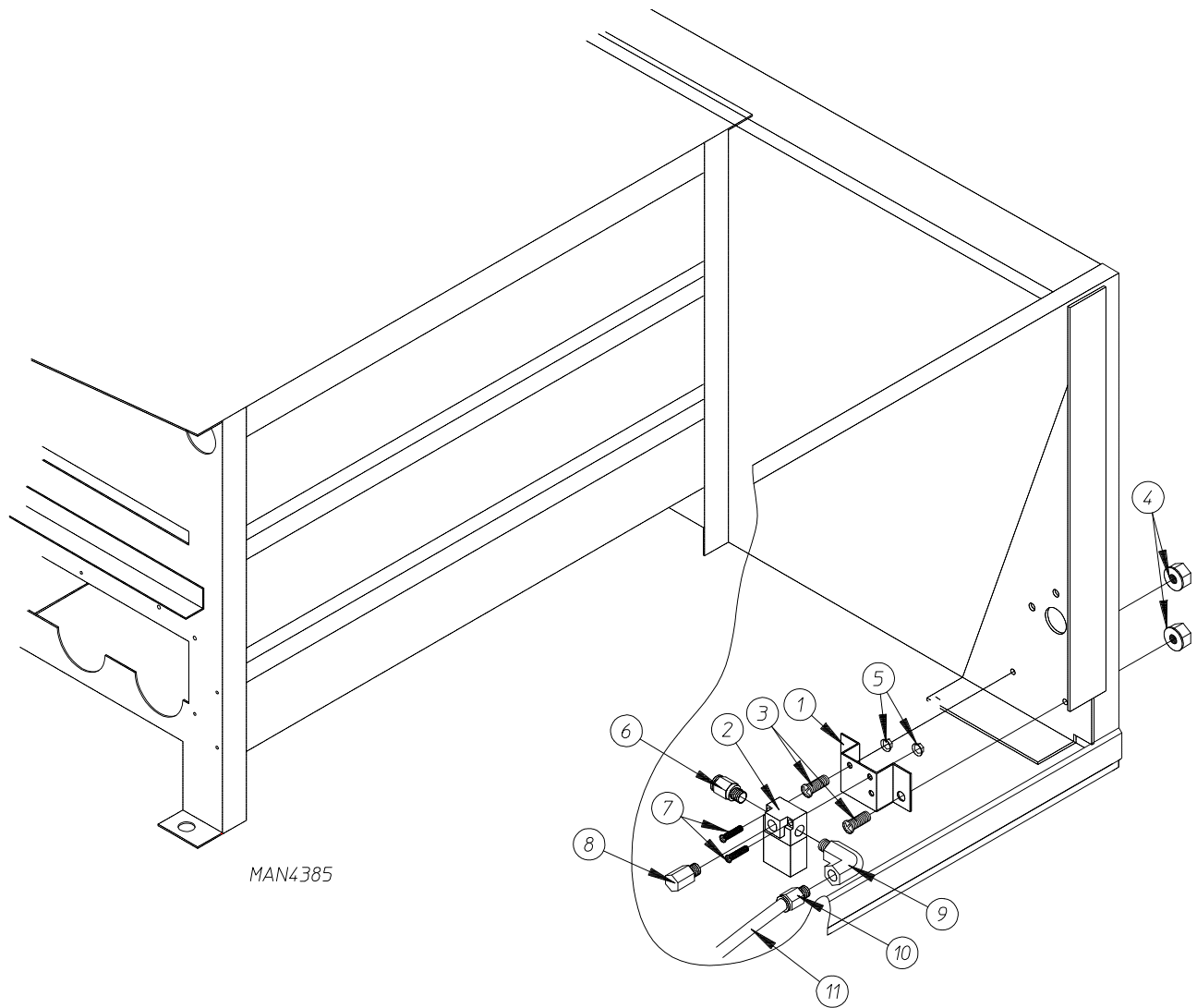

<u>Illus. No.</u>	<u>Part No.</u>	<u>Qty.</u>	<u>Description</u>
1	330987	1	Micro Valve Bracket
2	836002	1	Air Jet Solenoid
3	150111	2	1/4-20" Phillips Round Head Machine Screw
4	152014	2	1/4-20" Free Spin Wash Nut
5	151000	2	#6-32 Pal Nut
6	100472	1	1/4" x 1/8" Male Connector
7	150002	2	#6-32 x 1" Phillips Round Head Machine Screw
8	100520	1	1/8" N.P.T. Silencer (muffler)
9	143268	1	1/8" 90° Brass Straight Elbow
10	100472	1	1/4" x 1/8" Male Connector
11	143115	4	1/4" Poly-Flo Tubing (sold by the foot)

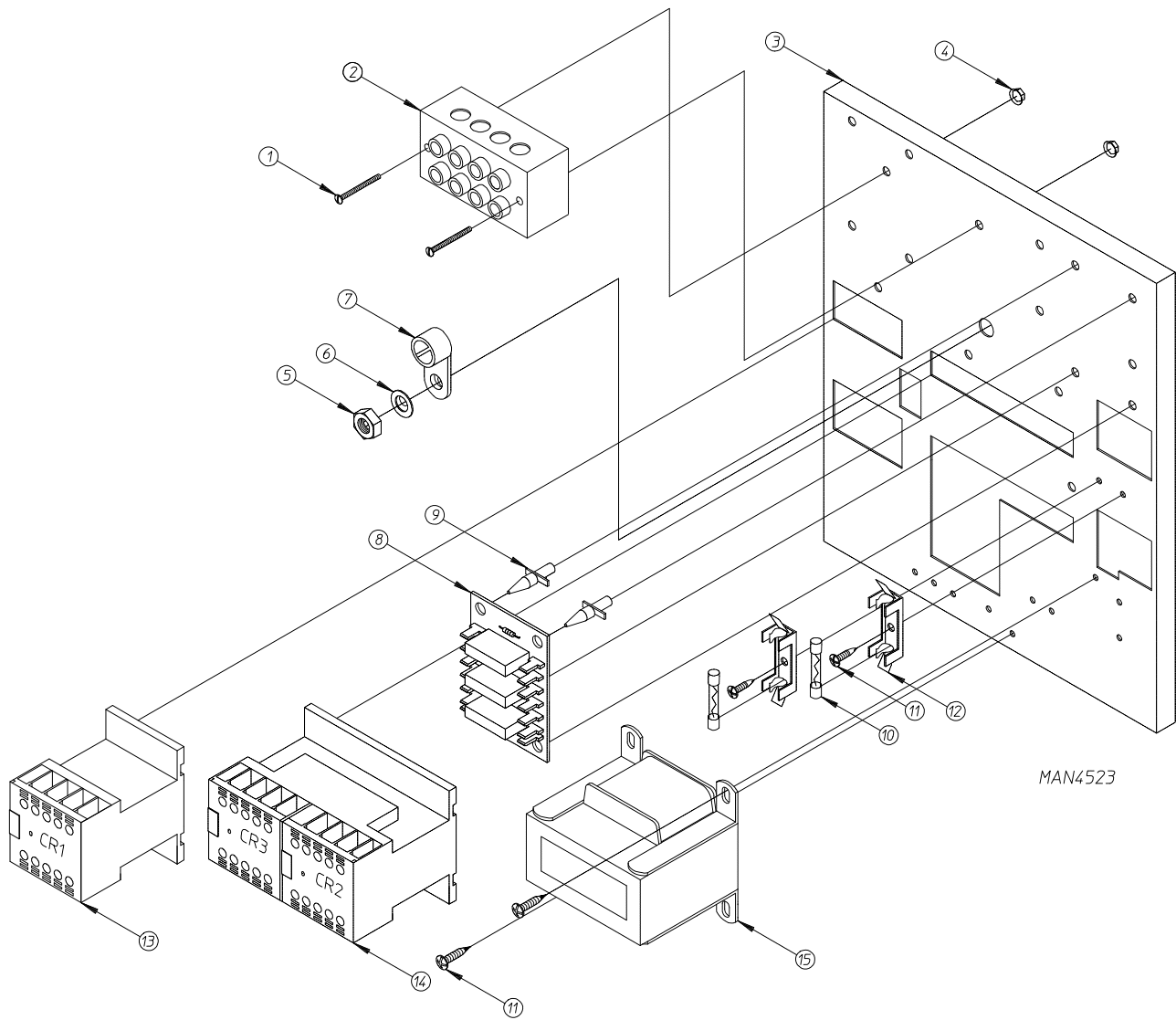

**For 60 Hz Gas and Steam Models ONLY**

<u>Illus. No.</u>	<u>Part No.</u>	<u>Qty.</u>	<u>Description</u>
1	150008	2	#6-32 x 1-1/4" Phillips Round Head Machine Screw
2	120701	1	4-Position Terminal Block
3	323743	1	Reversing Relay Panel
	820187	1	Reversing Relay Panel Assembly 208-240V (includes illus. nos. 1 through 15)
	820217	1	Reversing Relay Panel Assembly 480V (includes illus. nos. 1 through 15)
4	151000	2	#6-32 Pal Nut
5	152004	1	5/16-18 Hex Nut
6	153002	1	5/16" Lock Washer
7	121012	1	Ground Lug
8	137060	1	Arc Suppressor (A.S.) Board
9	137013	4	Nylon Standoff
10	136057	1	0.5-Amp 3AG Slo Blo Fuse
11	150301	3	#8-18 x 7/16" Phillips Round Head TEK Screw
12	136008	1	Fuse Holder
13	132455	1	9-Amp 2 HP Contactor
14	132448	1	Reversing Contactor
15	820174	1	208-240V 3 $\phi$ 60 Hz Transformer Assembly
	820134		480V/60 3 $\phi$ Hz Transformer Assembly (for models mfd. as of July 19, 1999)
	820241		480V 3 $\phi$ 60 Hz Transformer Assembly (for models mfd. prior to July 19, 1999)
	820216	1	480V 3 $\phi$ 60 Hz Transformer Assembly (for steam models Only)
--	820173	1	208-240V Reversing Relay Panel Wiring
--	819989	1	480V Reversing Relay Panel Wiring (for models mfd. prior to July 19, 1999)
--	820218	1	480V Reversing Relay Panel Wiring (for models mfd. prior to July 19, 1999)
--	842851	1	208-240V Reversing Relay Panel 9-Pin Connector Wiring
--	820186	1	480V Reversing Relay Panel 9-Pin Connector Wiring

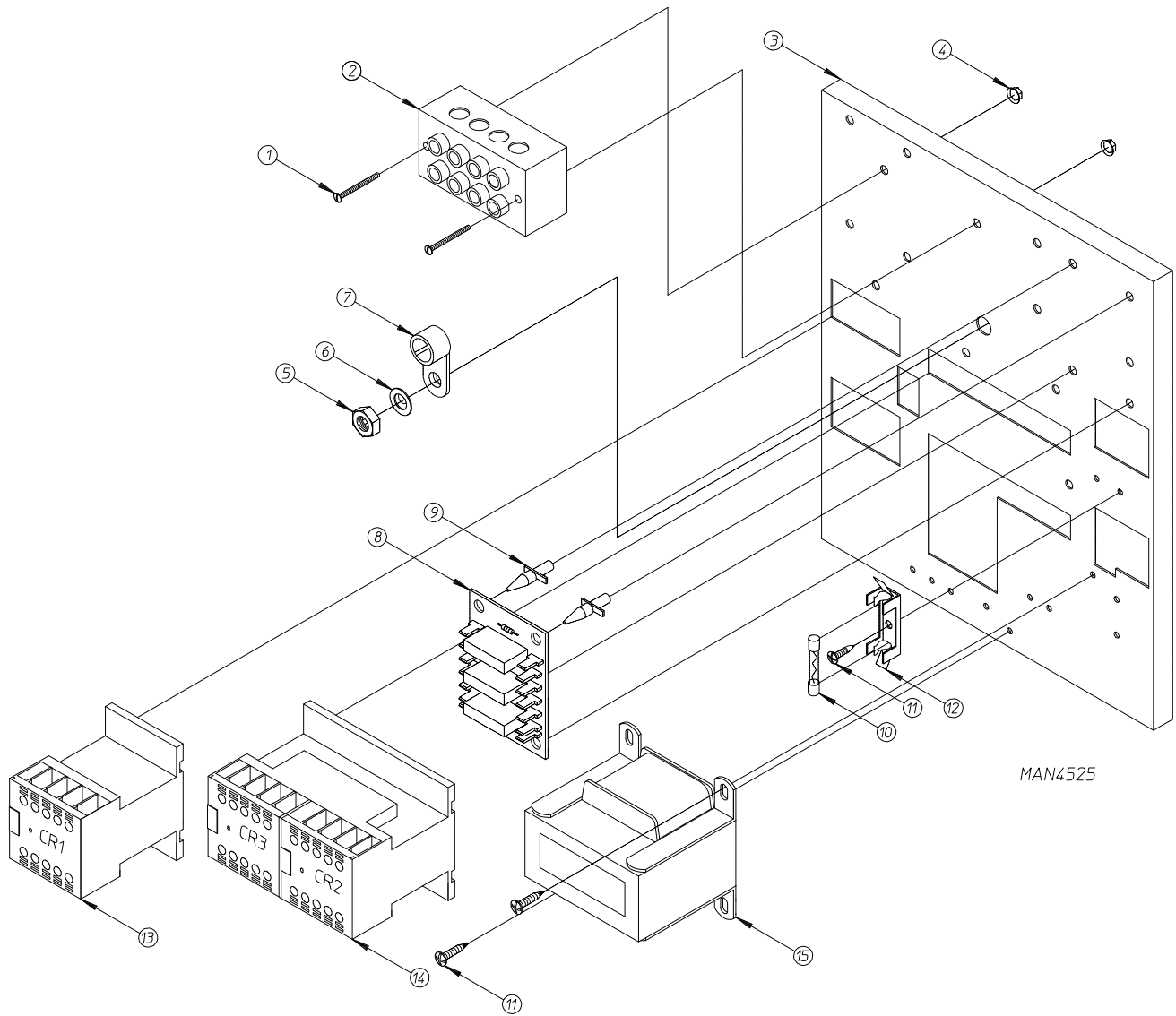

**For 50 Hz Gas and Steam Models ONLY**

<u>Illus. No.</u>	<u>Part No.</u>	<u>Qty.</u>	<u>Description</u>
1	150008	2	#6-32 x 1-1/4" Phillips Round Head Machine Screw
2	120701	1	4-Position Terminal Block
3	323743	1	Reversing Relay Panel
	820219	1	380-416V 3ø 50 Hz Reversing Relay Panel Assembly (includes illus. nos. 1 through 15) For Gas Models ONLY
	820192	1	380-416V 3ø 50 Hz Reversing Relay Panel Assembly (includes illus. nos. 1 through 15) For Steam Models ONLY
4	151000	2	#6-32 Pal Nut
5	152004	1	5/16-18 Hex Nut
6	153002	1	5/16" Lock Washer
7	121012	1	Ground Lug
8	137060	1	Arc Suppressor (A.S.) Board
9	137013	4	Nylon Standoff
10	136057	1	0.5-Amp (slo blo) Fuse
11	150301	3	#8-18 x 7/16" Phillips Round Head TEK Screw
12	136008	1	Fuse Holder ONLY
13	132455	1	9-Amp 2 HP Contactor
14	132448	1	Reversing Contactor
15	820220	1	380-416V 3ø 50 Hz Transformer Assembly
--	820188	1	380-416V 3ø 50 Hz Reversing Relay Panel Wiring
--	842851	1	380-416V 3ø 50 Hz Reversing Relay Panel 9-Pin Connector Wiring

For 60 Hz Electric Models ONLY

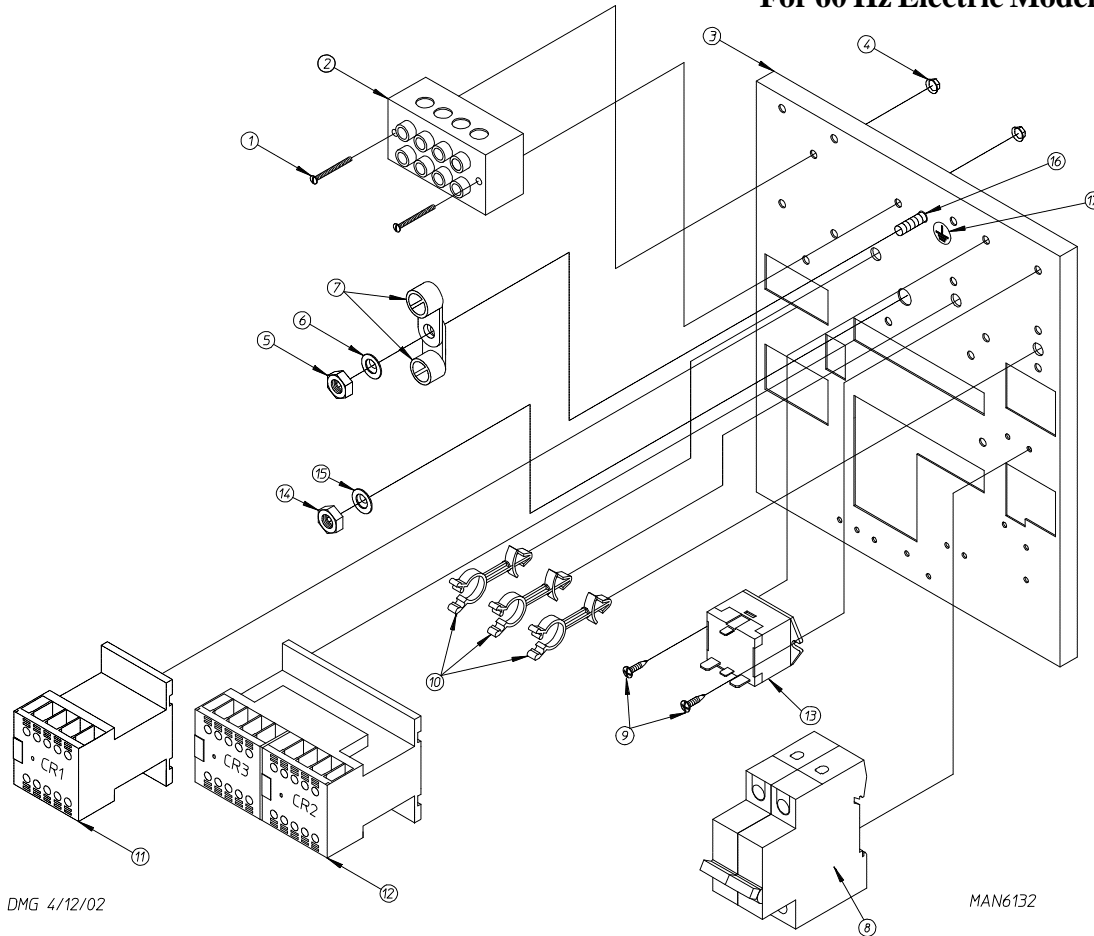

<u>Illus. No.</u>	<u>Part No.</u>	<u>Qty.</u>	<u>Description</u>
1	150009	2	#6-32 x 1-1/2" Phillips Pan Head Machine Screw
2	120701	1	4-Position Terminal Block
3	323743	1	Reversing Relay Panel
4	151000	2	#6-32 Pal Nut
5	152002	1	1/4-20 Hex Nut
6	153021	1	1/4" Lock Washer
7	121012	2	Ground Lug
8	135501	1	2-Pole 1-Amp Circuit Breaker
9	150301	2	#8-18 x 7/16" Phillips Head TEK Screw
10	121502	3	1/2" Wire Standoff
11	132496	1	9-Amp 2 HP Contactor with Coil Suppression
12	132497	1	Reversing Contactor with Coil Suppression
13	131932	1	Relay
14	152004	1	5/16-18 Hex Nut
15	153002	1	5/16" Lock Washer
16	153525	1	1/4-20 x 1" Self Clinching Stud
17	112075	1	Ground Label
*	824198	1	Reversing Relay Panel Wiring
*	824197	1	Reversing Relay Panel 9-Pin Connector Wiring
*	824199	1	Reversing Relay Panel Plug Harness

\* Not illustrated.



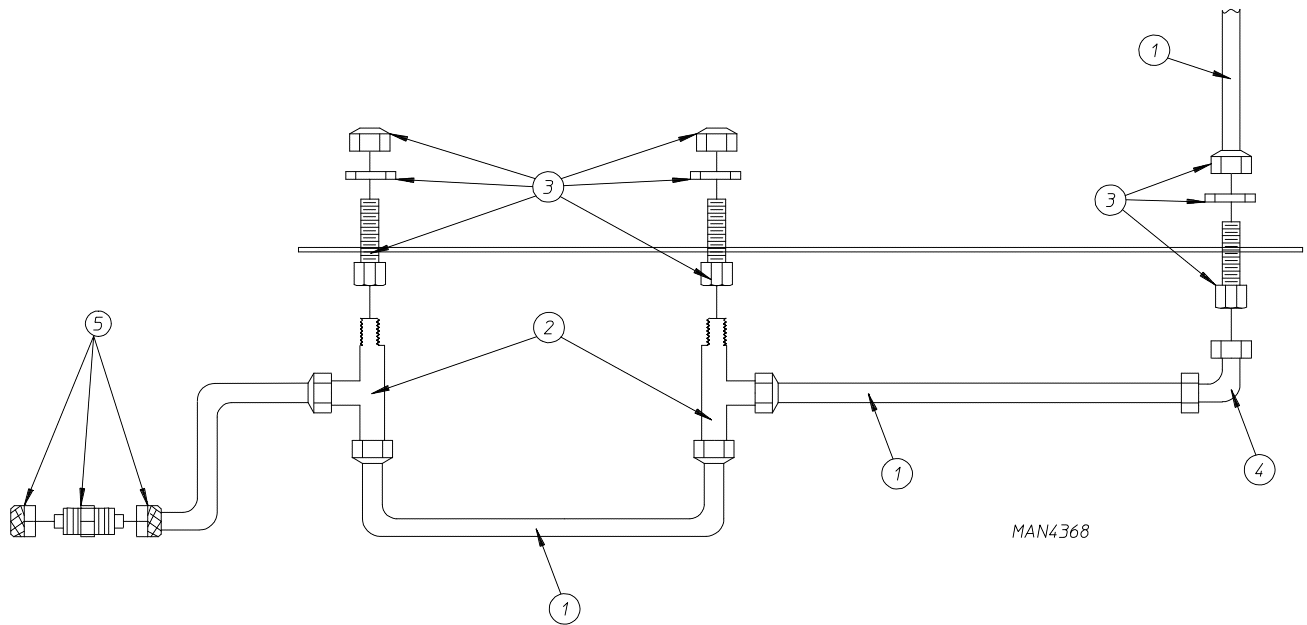

<u>Illus. No.</u>	<u>Part No.</u>	<u>Qty.</u>	<u>Description</u>
1	882157	6	1/4" Aluminum Tubing (sold by the foot)
2	143287	2	1/4" x 1/8" M.P.T. Tee
3	143259	3	Bulkhead Fitting 1/4" x 1/8" F.P.T.
4	143115	4	1/4" Diameter Poly-Flo Tubing
5	143154	1	1/4" Poly Union

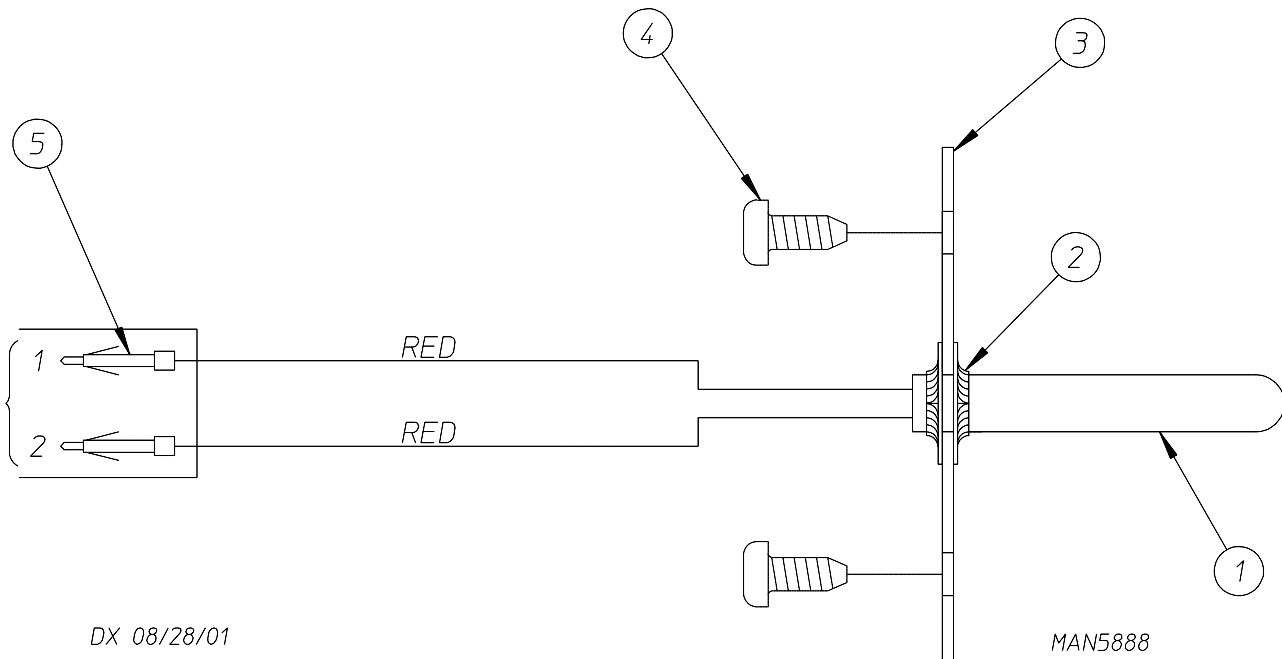

<u>Illus. No.</u>	<u>Part No.</u>	<u>Qty.</u>	<u>Description</u>
1	822752	1	Fire Suppression System (F.S.S.) Temperature Probe Assembly (includes illus. nos. 1 through 5)
2	154007	2	Push On Fastener
3	390390	1	Sensor Bracket ONLY
4	150301	2	#8-18 Phillips Pan Head TEK Screw
5	122647	1	Connector ONLY
	122700	2	Pins

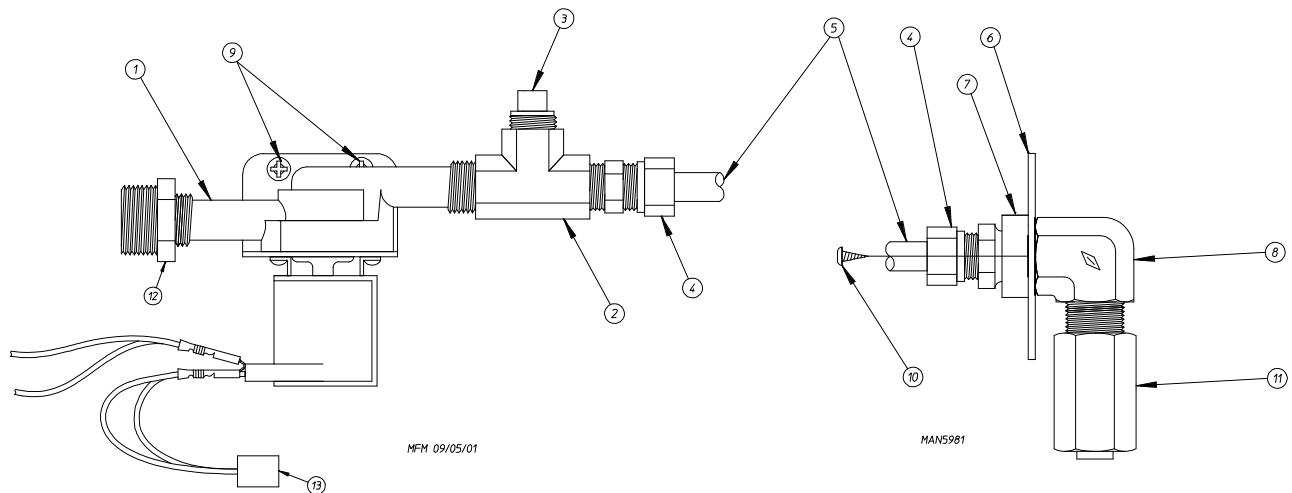

<u>Illus. No.</u>	<u>Part No.</u>	<u>Qty.</u>	<u>Description</u>
1	165114	1	Fire Suppression System (F.S.S.) Solenoid Valve 24V 50/60 Hz
2	143220	1	3/8" F.P.T. Brass Tee
3	143251	1	3/8" M.P.T. Brass Plug
4	143208	2	3/8" Comp x 3/8" M.P.T. Brass Connector
5	143099*	6'	3/8" OD x 0.035 Wall Copper Tubing
6	311588	1	Sprinkler Head Mounting Plate
7	143303	1	3/8" N.P.T. Brass Locknut
8	143155	1	3/8" Brass Elbow 90°
9	150430	2	#10 x 1/2" Self Drilling Screw
10	150301	2	#8-18 x 7/16" TEK Screw
11	143581	1	3 GPM 3/8" F.P.T. Spray Nozzle
12	142888	1	1/2" to 3/8" Bushing for Fire Suppression System (F.S.S.) Valve
13	824828	1	Arc Suppressor

\* Sold by the foot.

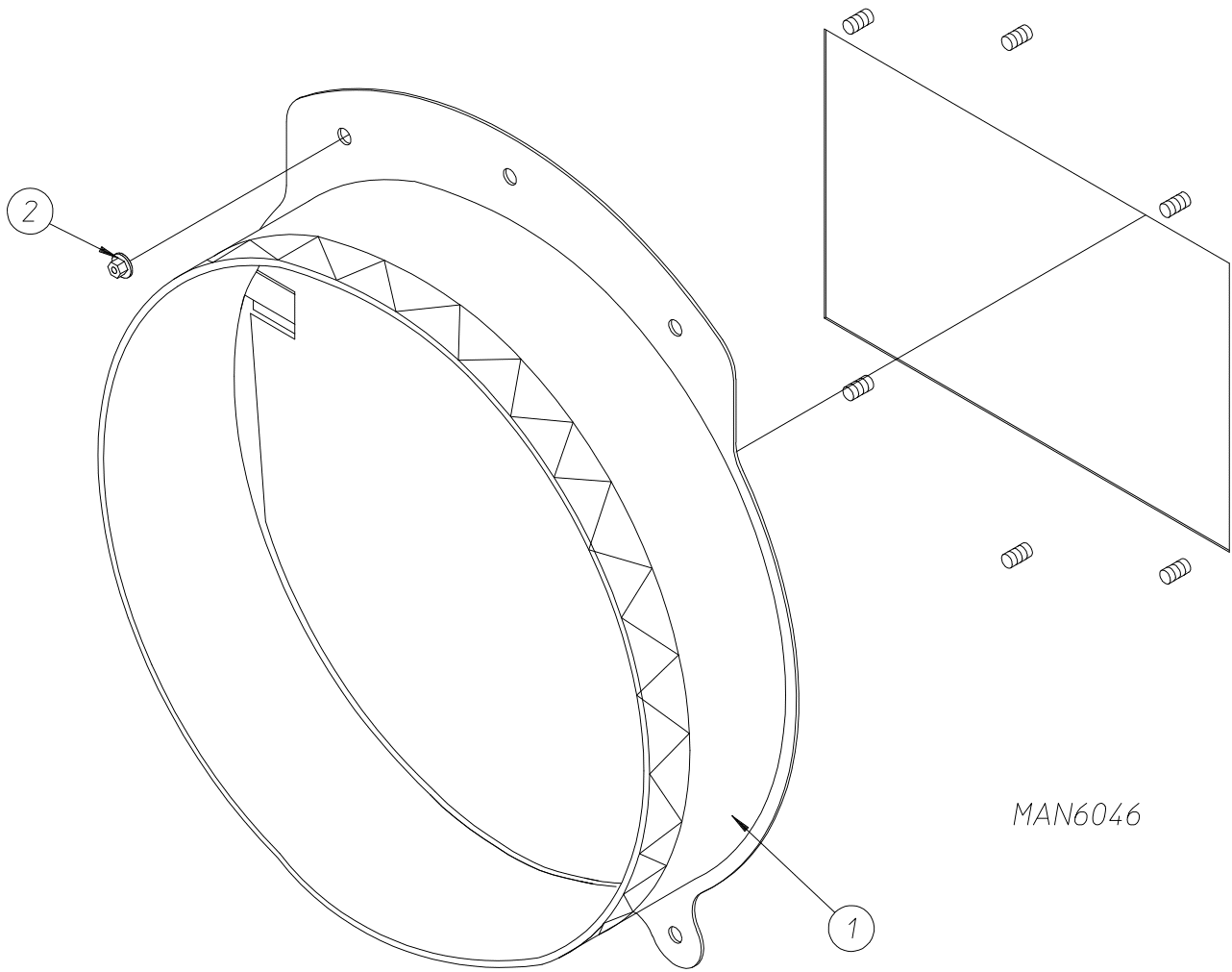

DMG 1/2/02

<u>Illus. No.</u>	<u>Part No.</u>	<u>Qty.</u>	<u>Description</u>
1	883281	1	Back Draft Damper Assembly
2	152014	5	1/4-20 Free Spin Wash Nut

