



Your **in**house Laundry Partner

D-40

Parts Manual

JLA Limited
Meadowcroft Lane, Halifax Road
Ripponden
West Yorkshire, England
HX6 4AJ

Telephone: 01422 822282 / Fax: 01422 824390

Retain This Manual In A Safe Place For Future Reference

J.L.A. products embody advanced concepts in engineering, design, and safety. If this product is properly maintained, it will provide many years of safe, efficient, and trouble free operation.

ONLY qualified technicians should service this equipment.

OBSERVE ALL SAFETY PRECAUTIONS displayed on the equipment or specified in the installation manual included with the dryer.

The following “**FOR YOUR SAFETY**” caution **must be** posted near the dryer in a prominent location.

FOR YOUR SAFETY

Do not store or use gasoline or other flammable vapors and liquids in the vicinity of this or any other appliance.

POUR VOTRE SÉCURITÉ

Ne pas entreposer ni utiliser d'essence ni d'autres vapeurs ou liquides inflammables à proximité de cet appareil ou de tout autre appareil.

We have tried to make this manual as complete as possible and hope you will find it useful. **Manufacturer** reserves the right to make changes from time to time, without notice or obligation, in prices, specifications, colors, and material, and to change or discontinue models.

Important

For your convenience, log the following information:

DATE OF PURCHASE _____ MODEL NO. **D-40** _____

DISTRIBUTOR'S NAME _____

Serial Number(s) _____

Replacement parts can be obtained from your reseller or **J.L.A.** When ordering replacement parts, you can FAX your order to **J.L.A.** at 01422 824390 or telephone your order directly to the **J.L.A.** Parts Department at 01422 822282. Please specify the dryer **model number** and **serial number** in addition to the **description** and **part number**, so that your order is processed accurately and promptly.

The illustrations on the following pages may not depict your particular dryer exactly. The illustrations are a composite of the various dryer models. Be sure to check the descriptions of the parts thoroughly before ordering.

“IMPORTANT NOTE TO PURCHASER”

Information **must be** obtained from your local gas supplier on the instructions to be followed if the user smells gas. These instructions **must be** posted in a prominent location near the dryer.

Table of Contents

OPL Control Door Assembly	
For Models Mfd. as of July 1, 2002	2
OPL Control Door Assembly	
For Models Mfd. prior to July 1, 2002	3
Phase 7 OPL Microprocessor Control Panel Assembly	4
Phase 7 OPL Microprocessor Control Box Assembly	5
Front Panel Assembly	
For Models Mfd. as of July 1, 2002	6
Front Panel Assembly	
For Models Mfd. prior to July 1, 2002	7
Main Door “Steel” Assembly	8
Main Door Switch Assembly	9
Basket (Tumbler)/Support Assemblies	10
Sensor Bracket Assemblies	11
Drop Lint Door Assembly	
For Models Mfd. as of July 1, 2002	12
Lint Trap Assembly	
For Models Mfd. as of July 1, 2002	13
Lint Drawer/Lint Drawer Switch Assembly	
For Models Mfd. prior to July 1, 2002	14
Idler Bearing Assembly	15
Basket (Tumbler) Bearing Assembly	16, 17
Motor Mount Assembly	18, 19
Direct Spark Ignition (DSI) Burner Assembly	20, 21
Hot Surface Ignition (HSI) Gas Burner Assembly	22, 23
Electric Oven Assembly	24, 25
Rear Electric Relay Panel Assembly	26, 27
Steam Coil/Air-Operated Steam Damper Assembly	28, 29
Outer Top/Back Guard Assemblies	30
S.A.F.E. Temperature Probe Assembly	31
S.A.F.E. Solenoid and Piping Assembly	32
Electrical Oven Component Application Chart	33
Additional Parts Available	34

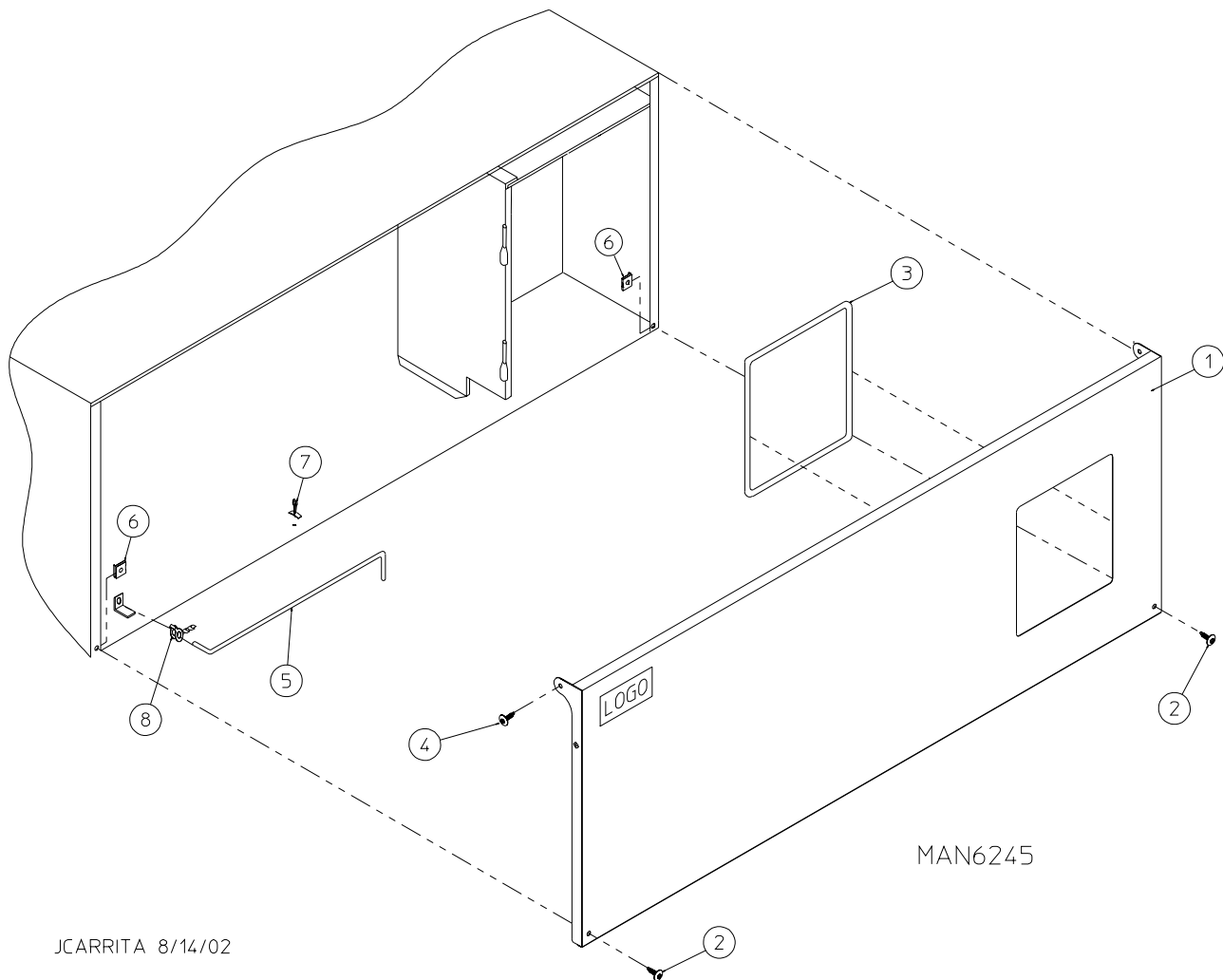

JCARRITA 8/14/02

<u>Illus. No.</u>	<u>Part No.</u>	<u>Qty.</u>	<u>Description</u>
1	883574	1	White OPL Control Door (includes illus. nos. 1 and 3)
2	150321	2	#10-32 x 1/2" Phillips Machine Screw
3	117604	4	Neoprene Sponge Tape (sold by the foot)
4	150317	2	#10-16 x 3/4" TORX + BTN Type 1
5	102502	1	Control Door Support Rod
6	154011	2	#10-32 Multi-Thread U-Nut
7	102603	1	Control Door Rod Support Catch
8	102601	1	Control Door Retainer Clip

For Models Mfd. prior to July 1, 2002

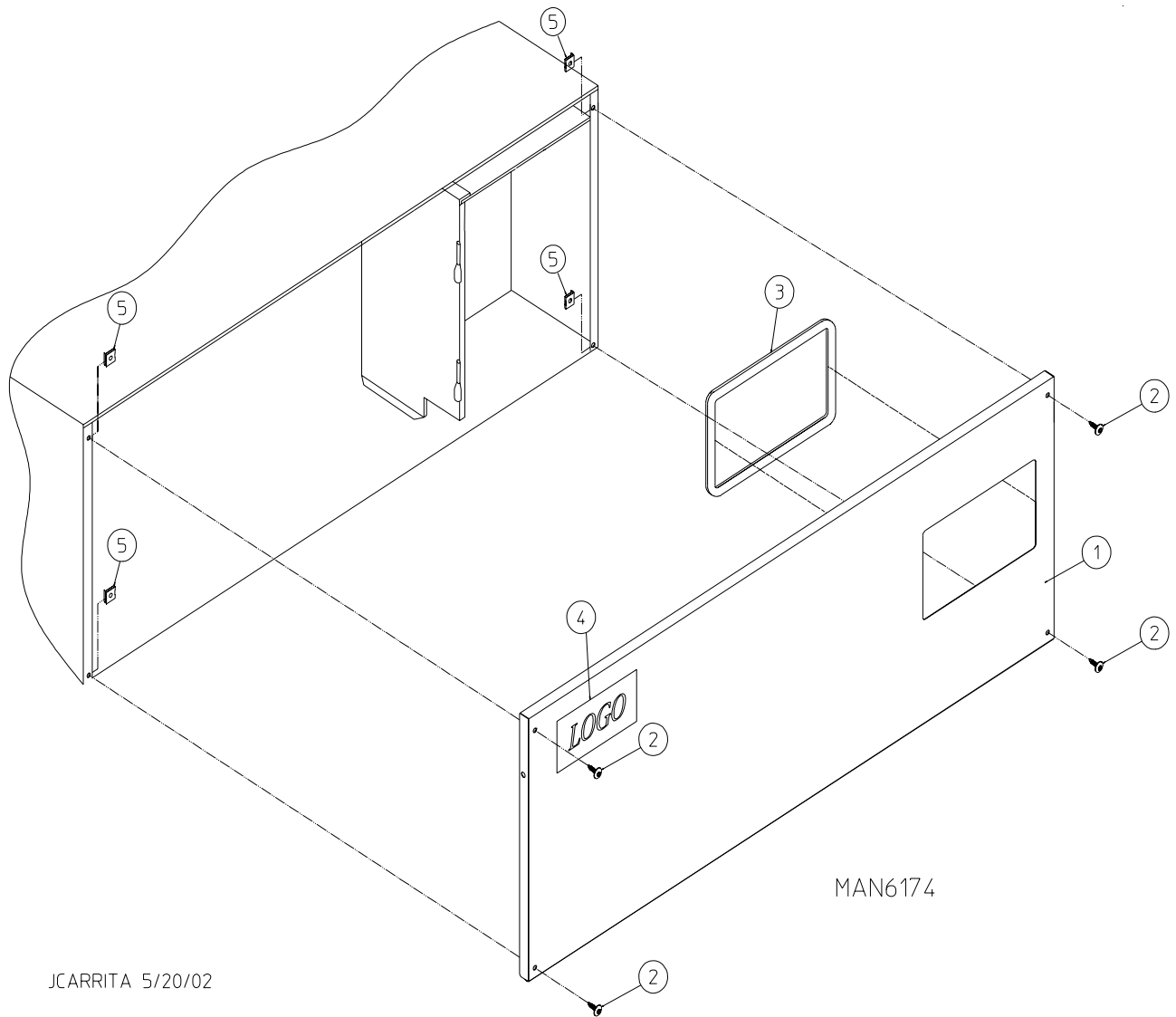

JCARRITA 5/20/02

<u>Illus. No.</u>	<u>Part No.</u>	<u>Qty.</u>	<u>Description</u>
1	883294	1	White Control Door Assembly (includes illus. nos. 1 and 4)
2	150217	2	#10-32 x 3/4" Phillips Pan Head Machine Screw
3	117604	4	Neoprene Sponge Tape (sold by the foot)
4	-----*	1	Logo
5	154011	4	#10-32 Multi-Thread U-Nut

* Contact factory for information.

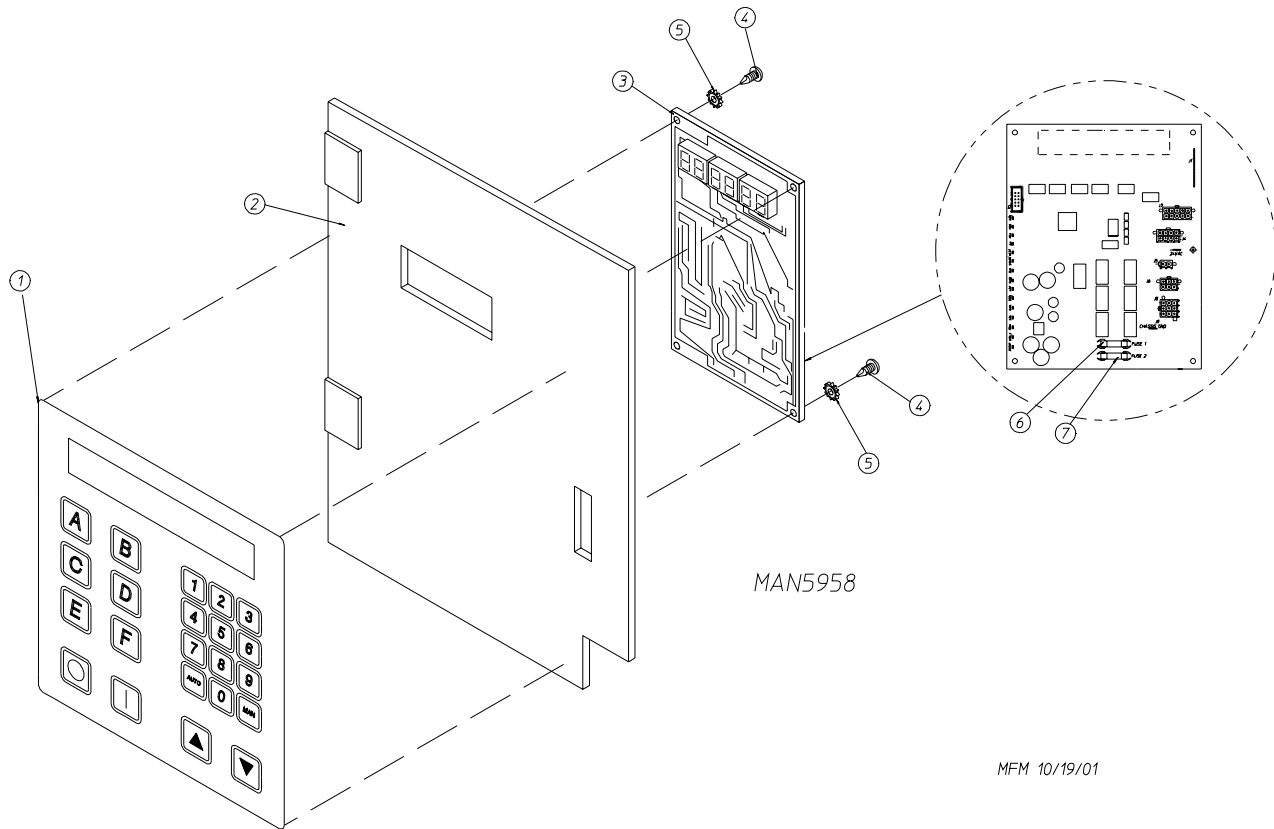

<u>Illus. No.</u>	<u>Part No.</u>	<u>Qty.</u>	<u>Description</u>
1	112571	1	Phase 7 OPL Keyboard
2	850984	1	Phase 7 Microprocessor Controller (computer) Panel ONLY
	883301	1	Phase 7 OPL Reversing Microprocessor Controller (computer) Control Panel Assembly Complete (includes illus. nos. 1 through 7)
3	883277	1	Phase 7 OPL Microprocessor Controller (computer) ONLY
4	150005	2	#6-32 x 3/4" Phillips Round Head Machine Screw
5	153010	2	#6 Star Washer
6	136016	1	5-Amp Fuse
7	136097	1	500 mA Fuse

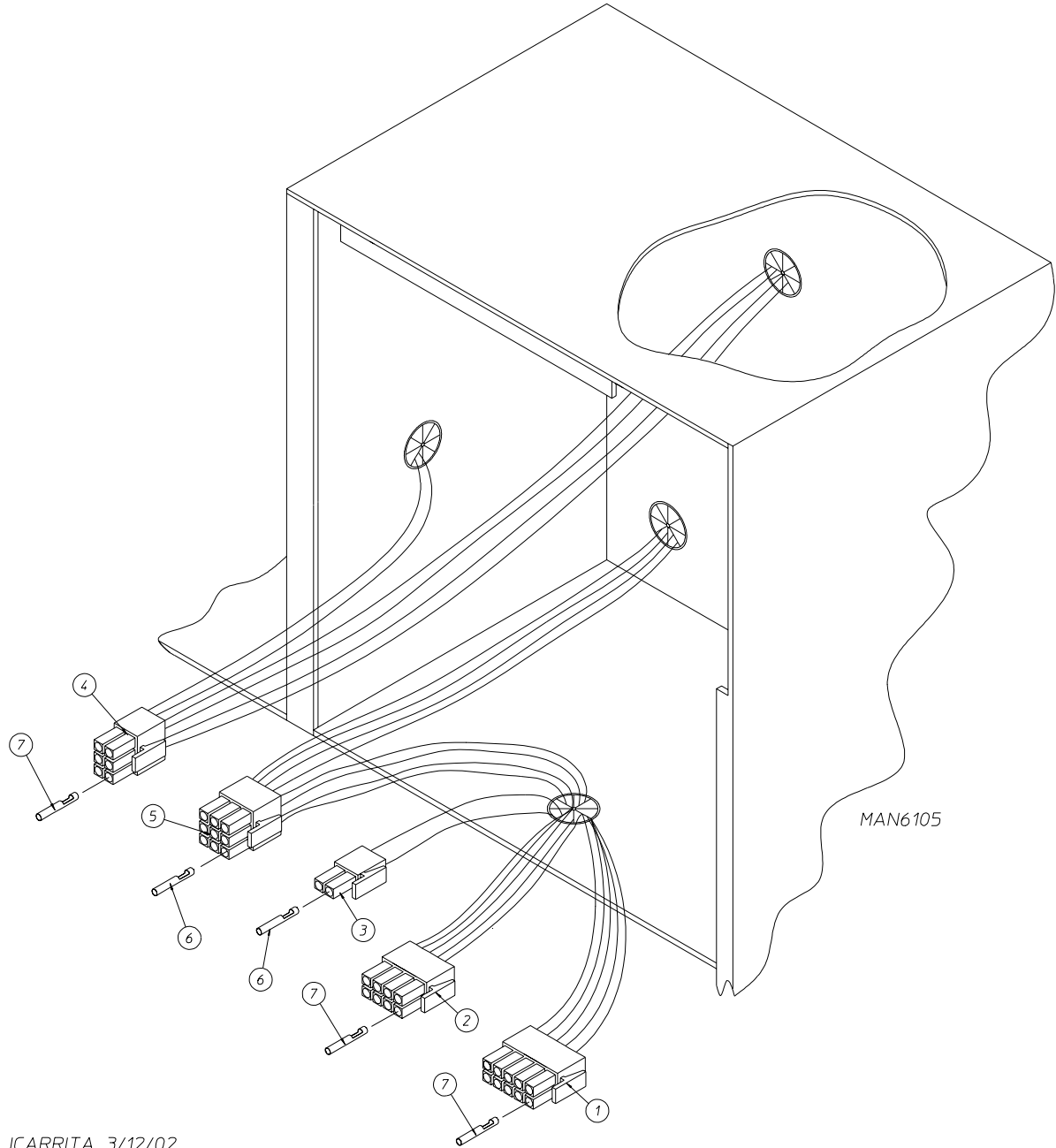

JCARRITA 3/12/02

Illus. No.	Part No.	Qty.	Description
1	122681	1	10-Pin Connector
2	122676	1	8-Pin Connector
3	122646	1	2-Pin Connector
4	122683	1	6-Pin Terminal
5	122640	1	9-Pin Terminal
6	122706	*	#20-16 U.M.N.L. Socket
7	122669	*	Female Crimp Terminal

* As needed.

For Models Mfd. as of July 1, 2002

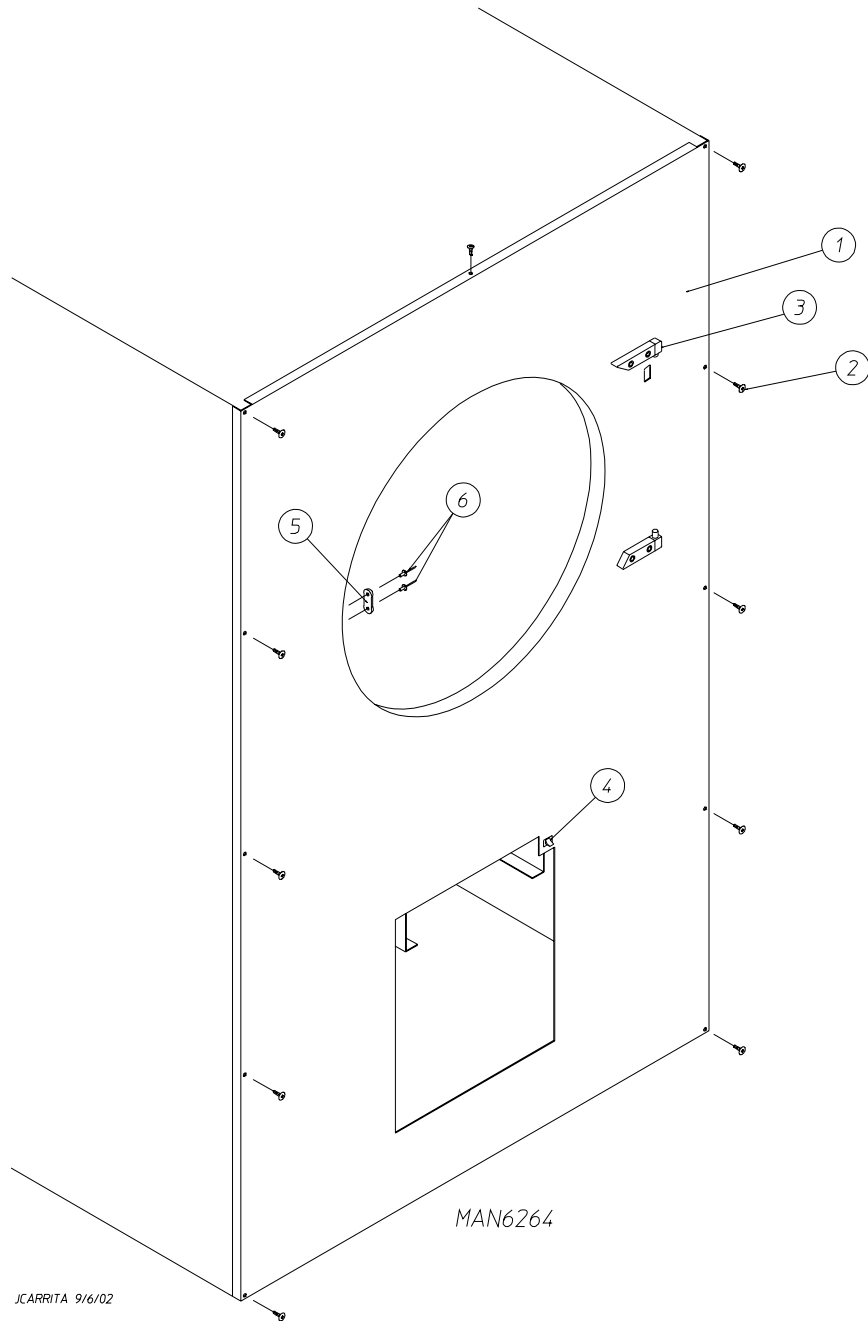

<u>Illus. No.</u>	<u>Part No.</u>	<u>Qty.</u>	<u>Description</u>
1	883567	1	White Front Panel Assembly (includes illus. nos. 1, 3, and 5 through 6)
2	150313	11	#10-16 x 1/2" TORX + BTN Type 1
	150318	1	25 IP TORX + Bit 1/4 Hex (for removal of TORX head screw)
3	-----	1	Main Door Hinge (refer to Main Door "Steel" Assembly on page 8)
4	122002	1	Lint Drawer Switch
5	170330	1	Friction Door Latch
6	154215	2	5/32" Pop Rivet

For Models Mfd. prior to July 1, 2002

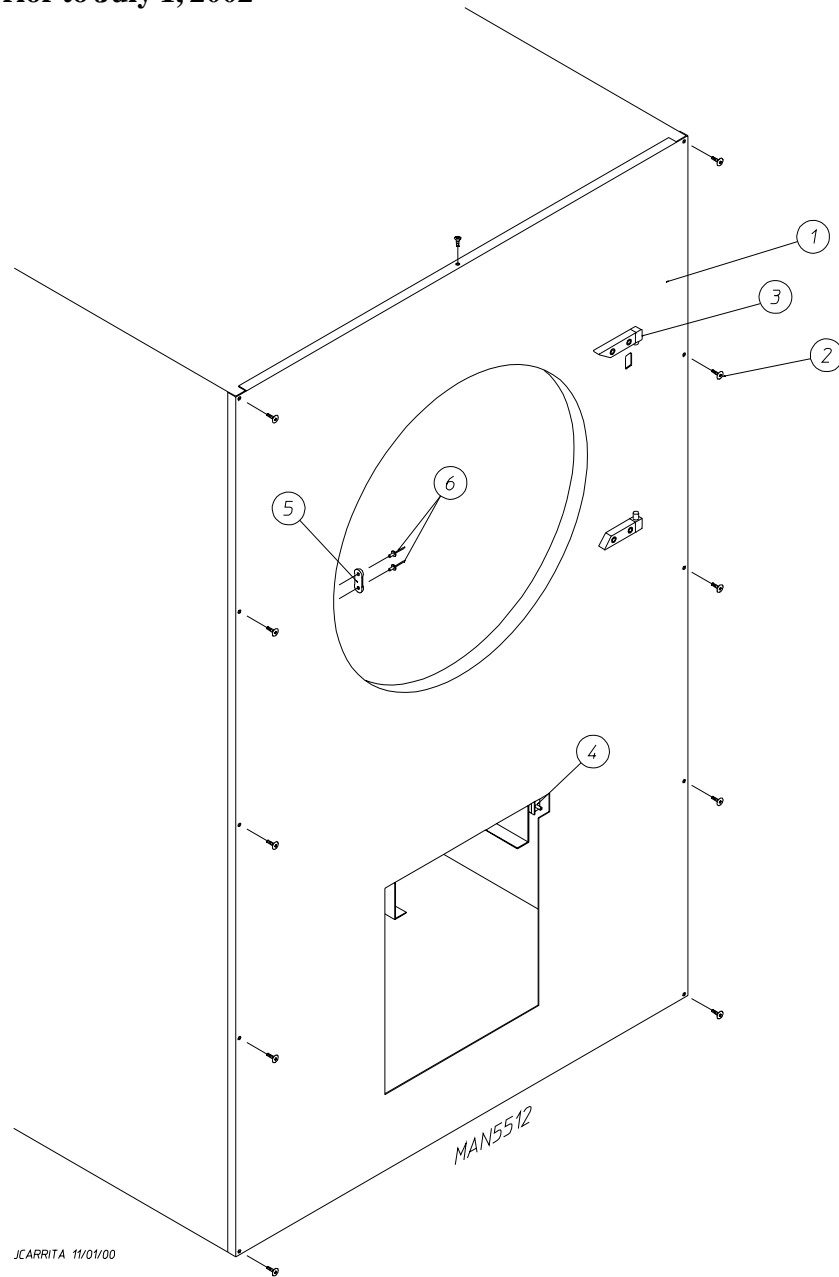

<u>Illus. No.</u>	<u>Part No.</u>	<u>Qty.</u>	<u>Description</u>
1	883137	1	White Front Panel Assembly (includes illus. nos. 1, 5, and 6)
2	150313	11	#10-16 x 1/2" TORX + BTN Type 1
	150318	1	25 IP TORX + Bit 1/4 Hex (for removal of TORX head screw)
3	-----	1	Main Door Hinge (refer to Main Door "Steel" Assembly on page 8)
4	-----	1	Lint Drawer Switch (refer to Lint Drawer/Lint Drawer Switch Assemblies on page 14)
5	881987	1	Friction Door Latch Kit (includes illus. nos. 5 and 6)
6	154215	2	5/32" Pop Rivet

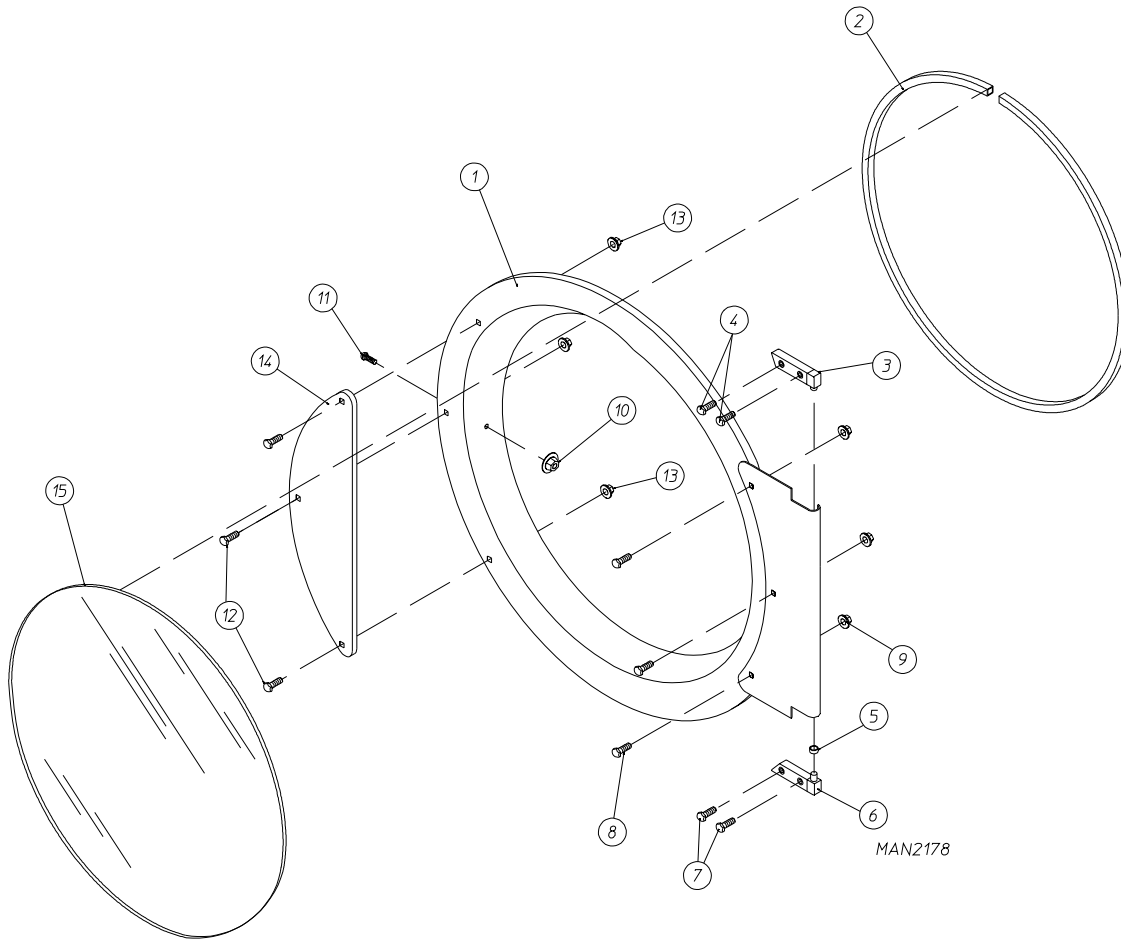

<u>Illus. No.</u>	<u>Part No.</u>	<u>Qty.</u>	<u>Description</u>
1	881150	1	Black Main Door Assembly Complete (includes illus. nos. 1, 2, and 8 through 15)
2	102354	1	Door Gasket
	170731	1	Black Gasket Adhesive (10.3 oz. cartridge)
3	881152	1	Black Top Hinge Block Assembly (includes illus. nos. 3 and 4)
4	150445	2	1/4-20 x 3/4" Black Cap Head Setscrew
5	153031	1	1/4" Nylon Washer
6	881151	1	Black Bottom Hinge Block Assembly (includes illus. nos. 5 through 7)
7	150445	2	1/4-20 x 3/4" Black Cap Head Setscrew
8	150683	3	1/4-20 x 5/8" Black Carriage Bolt
9	152014	3	1/4-20 Free Spin Wash Nut
10	151010	1	#10-32 Black Hex Acorn Nut
11	150120	1	Door Latch Screw
12	150683	3	1/4-20 x 5/8" Black Carriage Bolt
13	152014	3	1/4-20 Free Spin Wash Nut
14	881210	1	Black Main Door Handle ONLY
15	102211	1	20-7/16" Door Glass
	170731	1	Black Glass Adhesive (10.3 oz. cartridge)

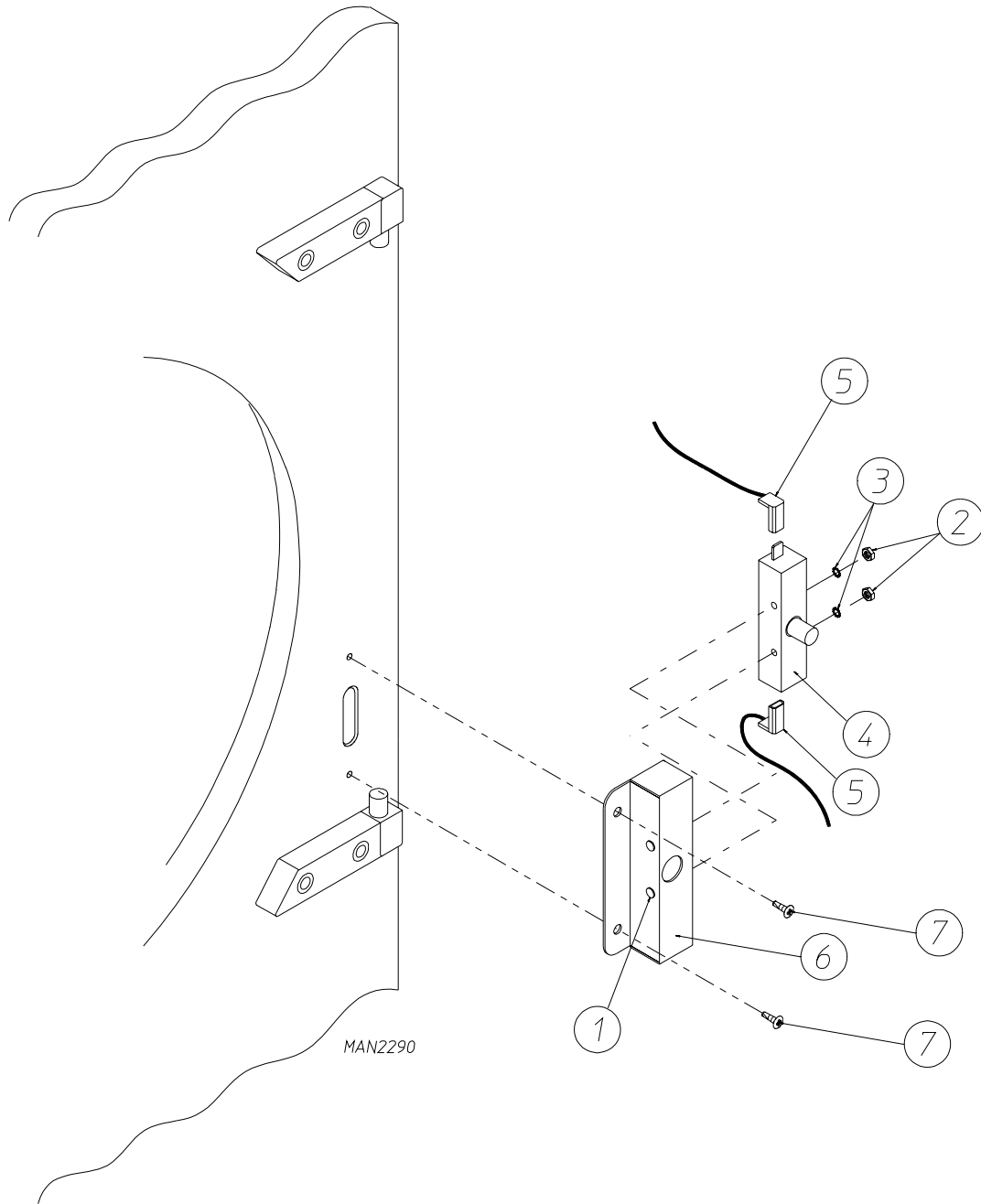

<u>Illus. No.</u>	<u>Part No.</u>	<u>Qty.</u>	<u>Description</u>
1	150006	2	#6-32 x 7/8" Phillips Pan Head Machine Screw
2	152013	2	#6-32 Hex Nut
3	153010	2	#6 Star Washer
4	137005	1	Door Switch
5	122636	2	Flag Terminal
6	881211	1	Black Main Door Switch Housing ONLY
	881153	1	Black Main Door Switch Housing Complete (includes illus. nos. 1 through 4 and 6)
7	150301	2	#8-18 x 7/16" Phillips Pan Head TEK Screw

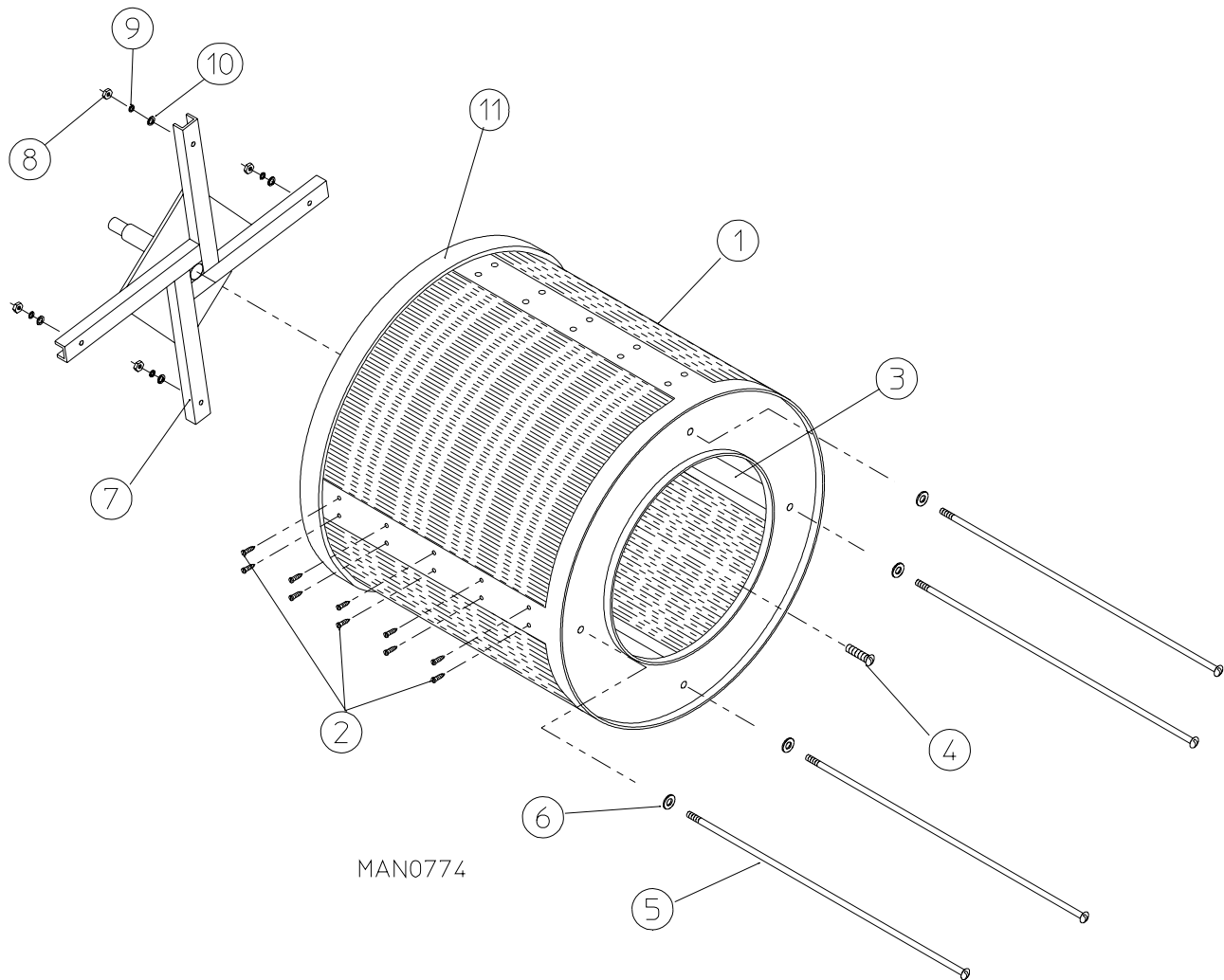

<u>Illus. No.</u>	<u>Part No.</u>	<u>Qty.</u>	<u>Description</u>
1*	817094	1	Basket (tumbler) ONLY (without felt collar)
	883300	1	Basket (tumbler)/Support Assemblies (includes illus. nos. 1 through 10)
2	150309	40	#10-16 x 1/2" Hex Head TEK Crimptite Screw
3	322066	2	Basket (tumbler) Rib ONLY
	322067	2	Tapered Basket (tumbler) Rib ONLY
4	150518	1	5/16-18 x 3/8" Socket Button Head Screw
5	100918	4	3/8-16 x 26-3/4" Tie Rod
6	153004	4	3/8" Flat Washer
7	882517	1	Basket (tumbler) Support ONLY
8	152005	4	3/8-16 Hex Nut
9	153005	4	3/8" Lock Washer
10	153004	4	3/8" Flat Washer
11	116002	1	Felt Collar ONLY
--	401010	1	#847 Adhesive for Felt Collar (5.0 oz. tube)

* Felt collar *is not included* and **must be** ordered separately.

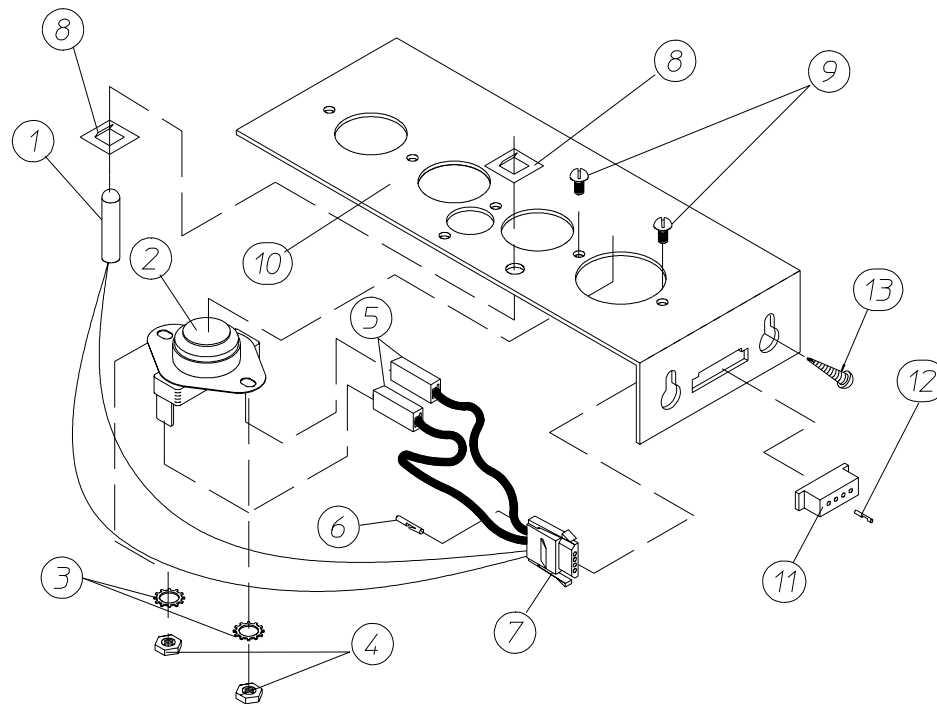

MICROPROCESSOR SENSOR BRACKET ASSEMBLY

JCARRITA 2/1/02

MAN6073

<u>Illus. No.</u>	<u>Part No.</u>	<u>Qty.</u>	<u>Description</u>
1	880251	1	1/4" Temperature Sensor Probe Assembly (includes illus. nos. 1 and 5 through 8)
2	130103	1	225° Hi-Limit Thermostat
3	153010	2	#6 Star Washer
4	152000	2	#6-32 Hex Nut
5	121028	2	Insulated Terminal ONLY
6	122701	4	Socket Terminal ONLY
7	122605	1	4-Pin Socket Connector ONLY
8	154007	2	1/4" Tinnerman Push On Fastener
9	150005	2	#6-32 x 1/4" Phillips Round Head Machine Screw
10	801424	1	Microprocessor Sensor Bracket Assembly Complete (includes illus. nos. 1 through 10) For Models Mfd. as of July 1, 2002
	817046	1	Microprocessor Sensor Bracket Assembly Complete (includes illus. nos. 1 through 10) For Models Mfd. prior to July 1, 2002
	305007	1	Sensor Bracket ONLY (for models mfd. as of July 1, 2002)
	322062	1	Sensor Bracket ONLY (for models mfd. prior to July 1, 2002)
11	122604	1	4-Pin Connector ONLY
12	122700	4	Pin Terminal ONLY
13	150301	2	#8-18 x 7/16" Phillips Pan Head TEK Screw

For Models Mfd. as of July 1, 2002

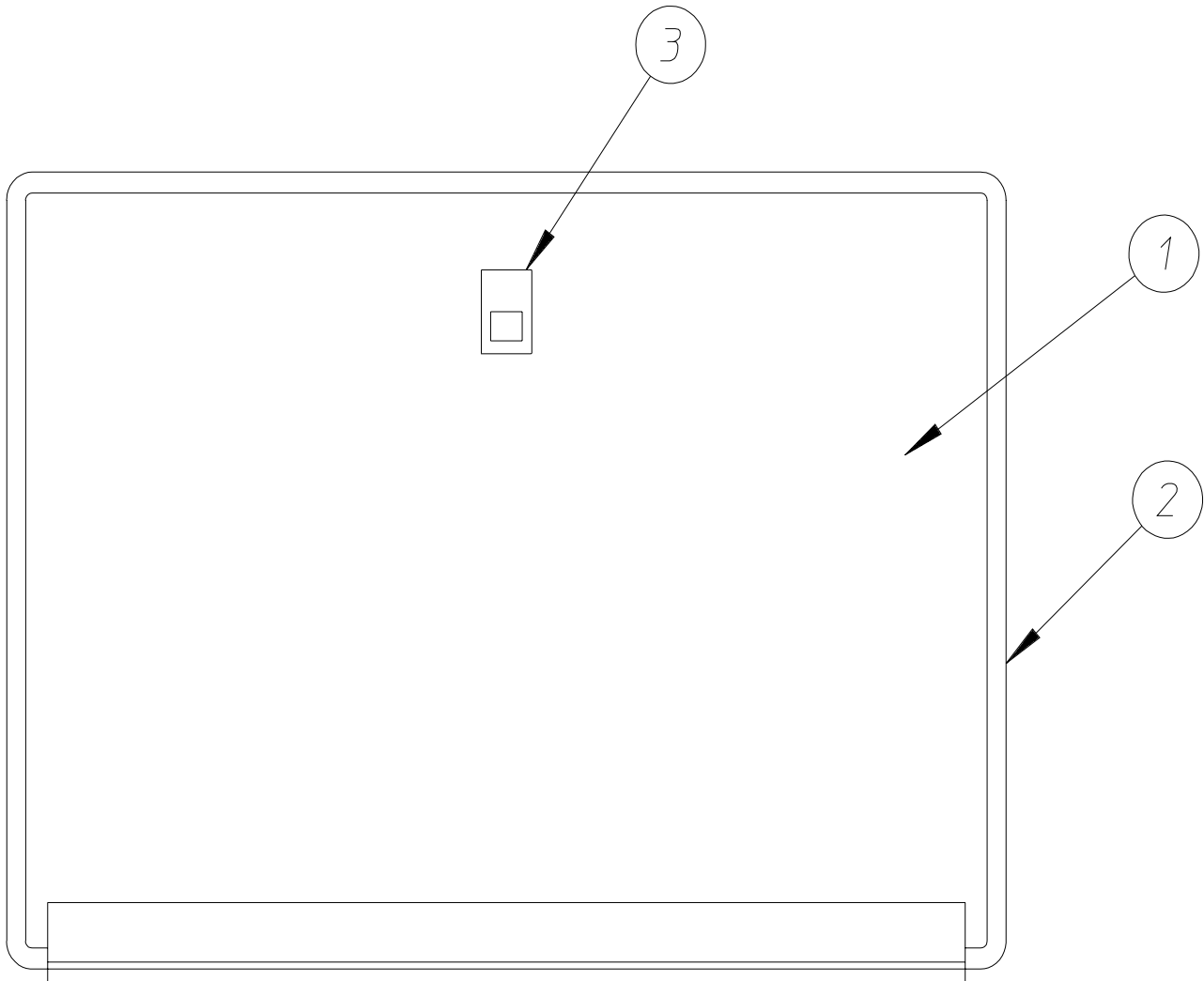

ST 12/11/01

MAN6030

<u>Illus. No.</u>	<u>Part No.</u>	<u>Qty.</u>	<u>Description</u>
1	802277	1	Drop Lint Door (for OPL models) (includes illus. nos. 1 through 3)
2	117604	5	Sponge Tape (sold by the foot)
3	170226	1	Slide Latch

For Models Mfd. as of July 1, 2002

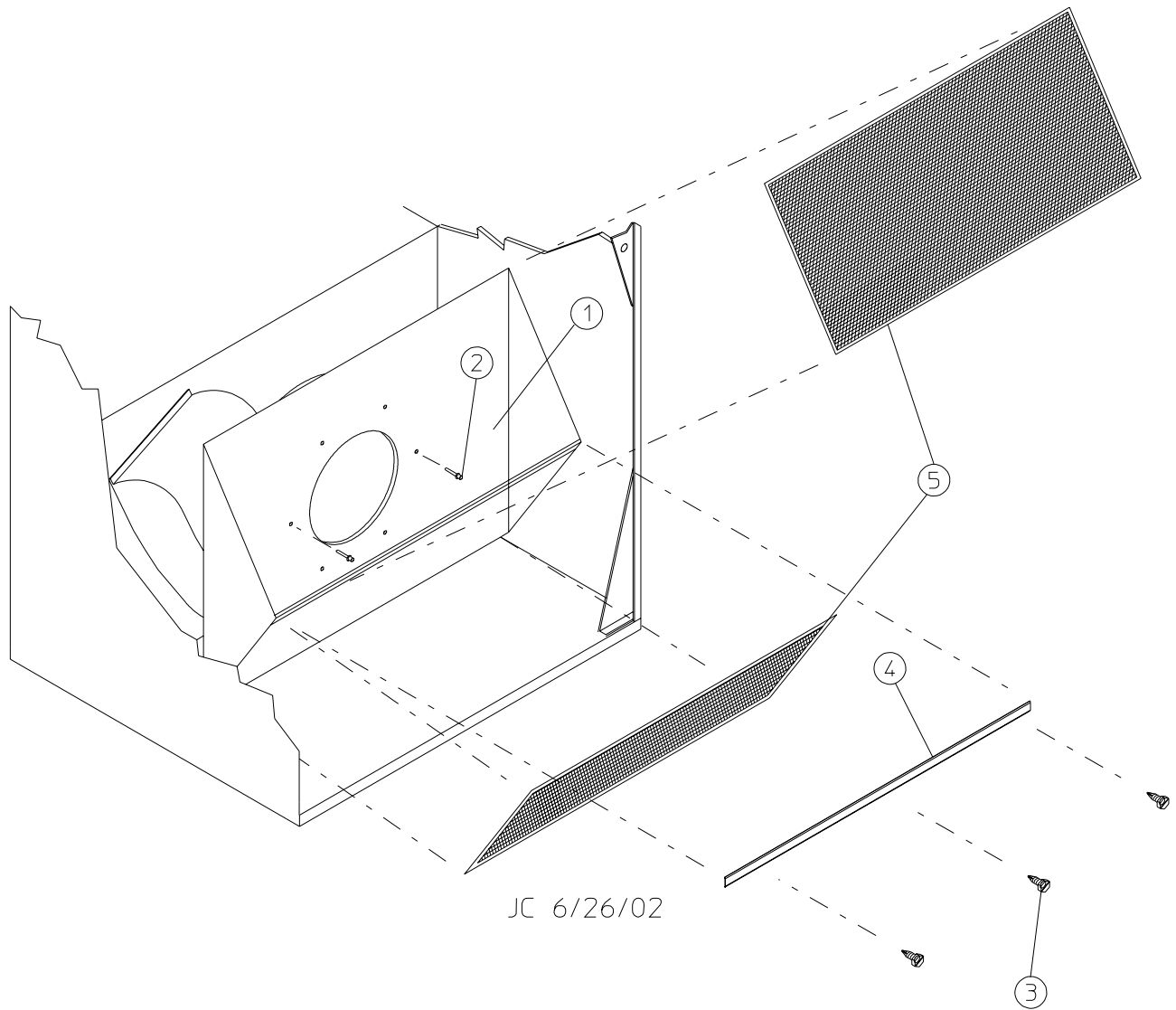

MAN6192

<u>Illus. No.</u>	<u>Part No.</u>	<u>Qty.</u>	<u>Description</u>
1	800401	1	Lint Trap Assembly Complete (includes illus. nos. 1 and 3 through 5)
	800443	1	Lint Trap ONLY
2	154200	6	5/32" Pop Rivet
3	150300	3	#10-16 x 1/2" Hex Washer TEK Screw
4	304100	1	Lint Screen Holder ONLY
5	800500	2	Lint Screen Assembly

For Models Mfd. prior to July 1, 2002

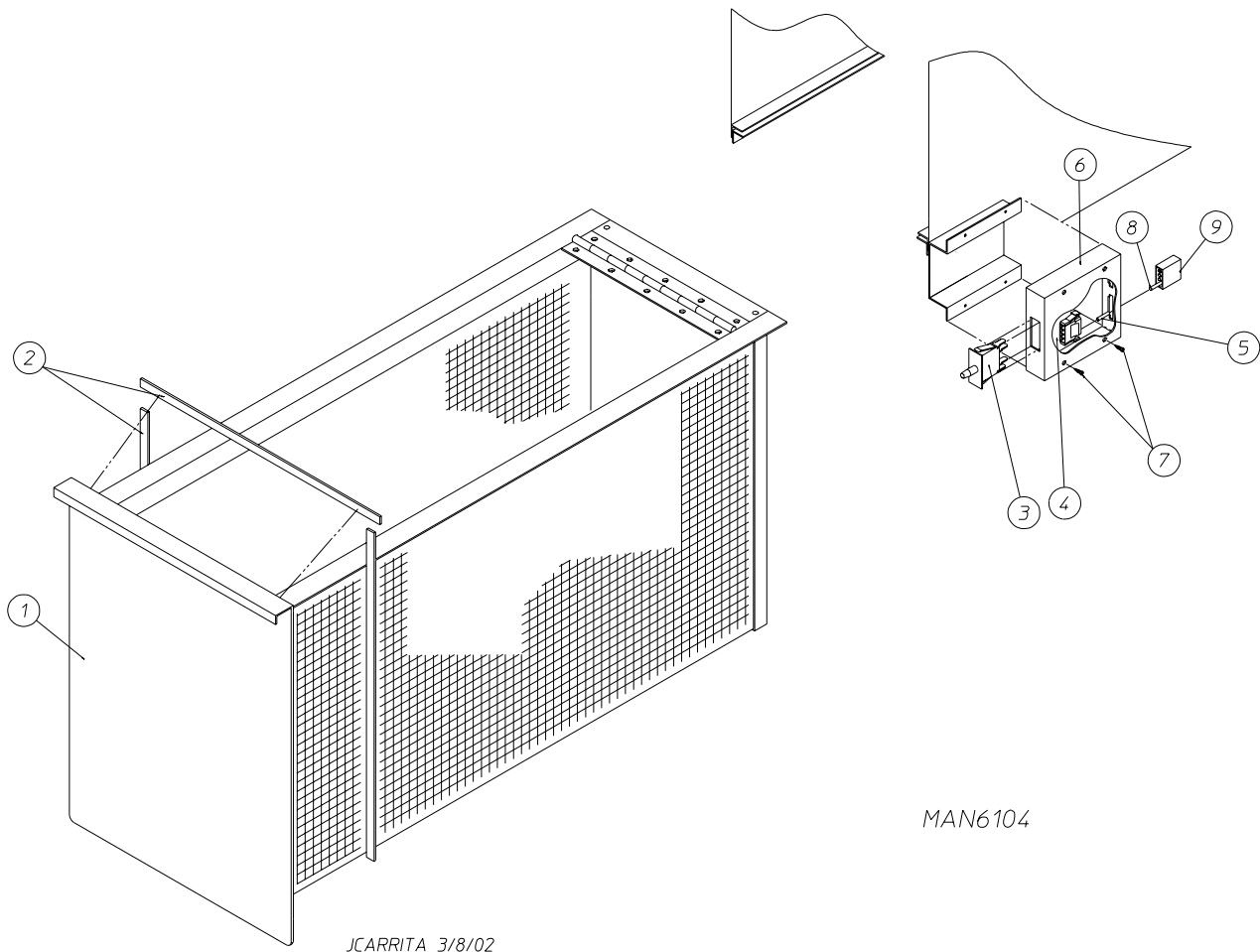

Illus. No.	Part No.	Qty.	Description
1	883155	1	White Lint Drawer Assembly (includes illus. nos. 1 and 2)
2	117605	5	Gasket (sold by the foot)
3	122116	1	Lint Drawer Switch
4	122605	1	4-Pin Socket Connector ONLY
5	122701	*	Socket Terminal ONLY
	122801	1	Pin/Socket Extraction Tool
6	833123	1	Lint Drawer Switch Box Assembly (includes illus. nos. 4 through 7)
	304136	1	Lint Drawer Switch Box ONLY
7	150301	2	#8-18 x 7/16" Phillips Pan Head TEK Screw
8	122700	*	Pin Terminal ONLY
9	122604	1	4-Pin Connector ONLY

* As required.

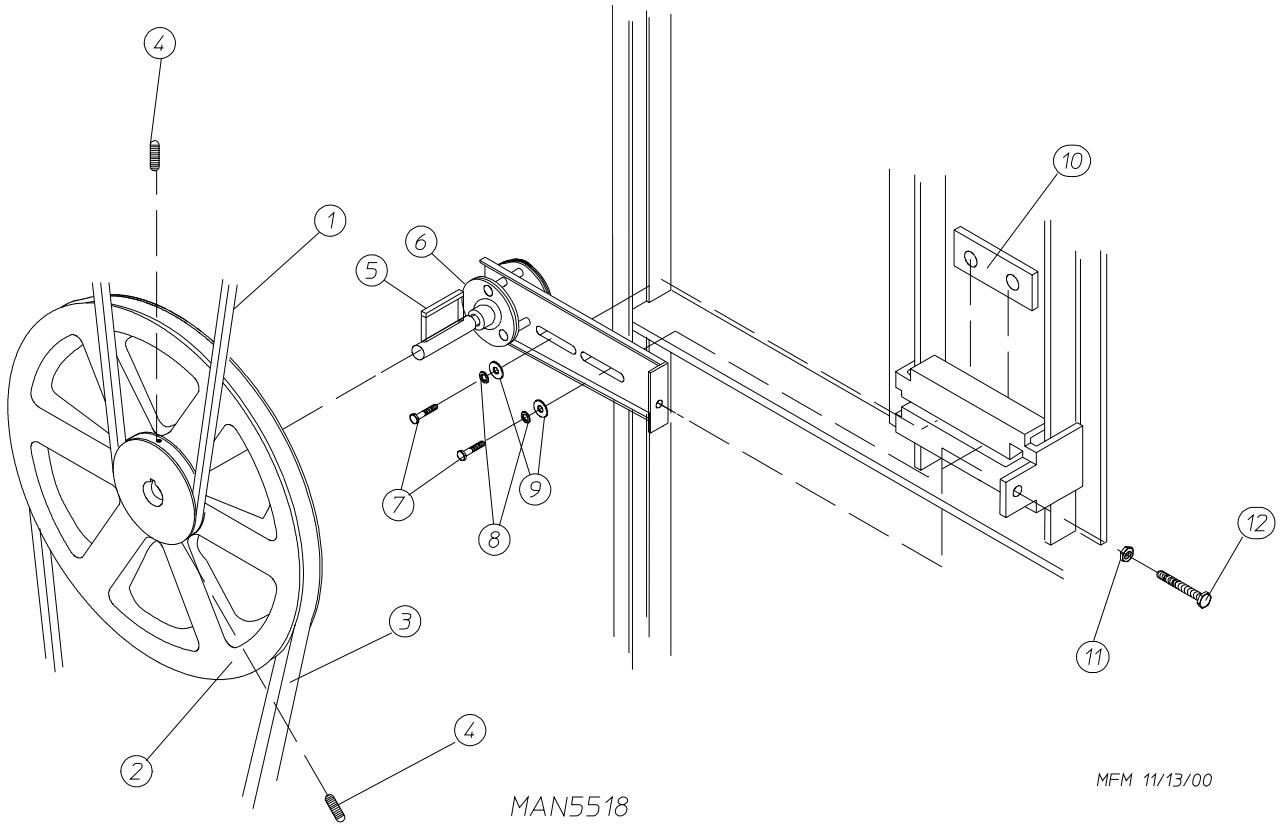

<u>Illus. No.</u>	<u>Part No.</u>	<u>Qty.</u>	<u>Description</u>
1	100100	1	5L-660 V-Belt (basket [tumbler] to idler)
2	101129	1	9" x 2-1/2" Compound Pulley
3	100105	1	4L-520 V-Belt (idler to motor)
4	154301	2	5/16-18 x 1" Allen Setscrew
5	100705	1	3/16" x 3/16" x 1-3/8" Key
6	882576	1	Idler Bearing Assembly Complete (includes illus. nos. 5 through 12)
7	150617	2	3/8-16 x 1" Hex Head Machine Bolt
8	153005	2	3/8" Lock Washer
9	153004	2	3/8" Flat Washer
10	801009	1	Idler Square Washer
11	152004	1	5/16-18 Hex Nut
12	150509	1	5/16-18 x 3" Hex Head Machine Bolt

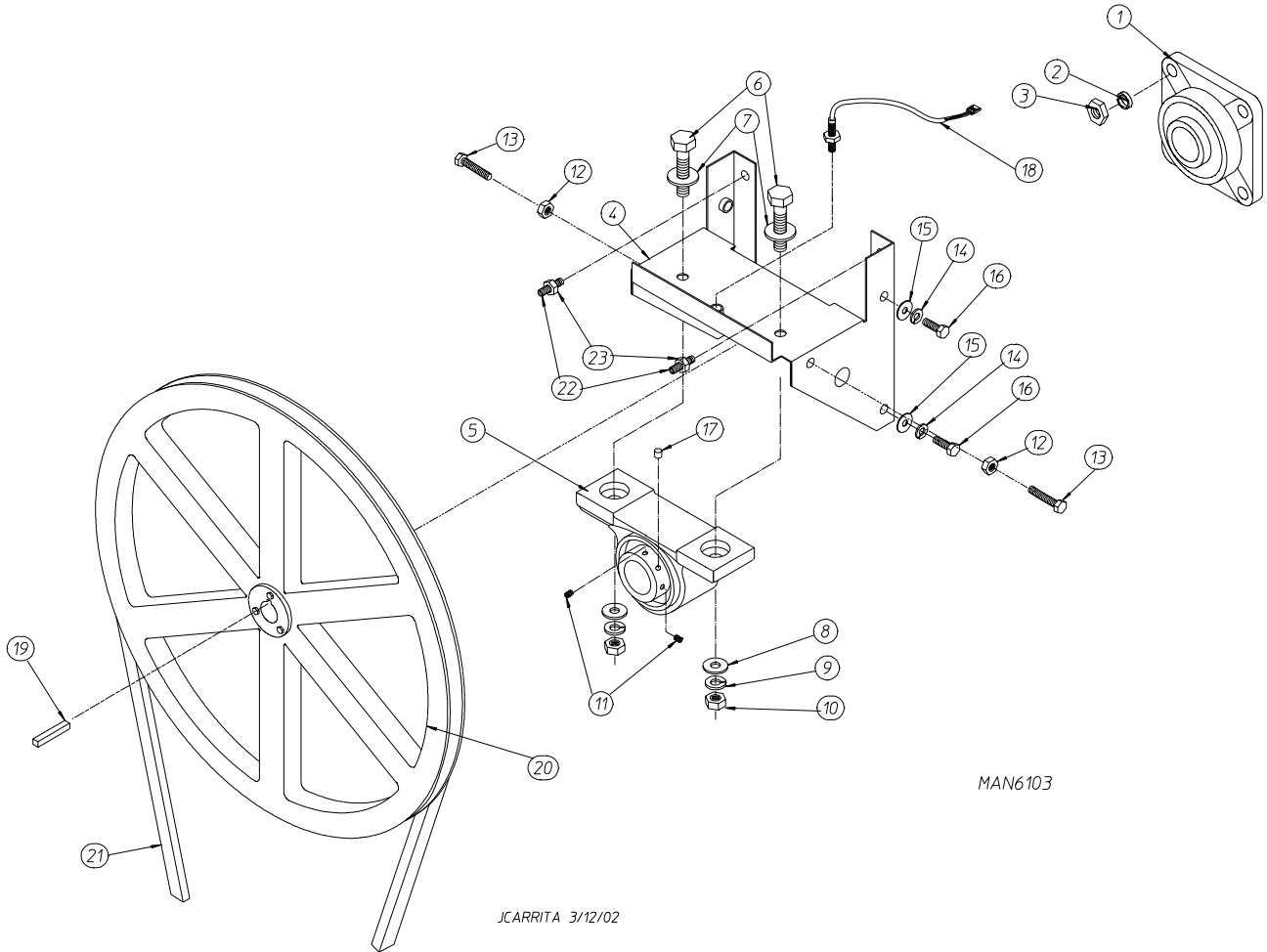

<u>Illus. No.</u>	<u>Part No.</u>	<u>Qty.</u>	<u>Description</u>
1	880220	1	1-3/4" Flange Bearing
2	153025	4	9/16" Lock Washer
3	152050	4	9/16-12 Hex Nut
4	883387	1	Pillow Block Bearing Assembly Complete (includes illus. nos. 4 through 18, 22, and 23)
	882543	1	Pillow Block Bearing Platform ONLY
5	880779	1	1-3/8" Pillow Block Bearing
6	150601	2	3/8-16 x 2" Hex Bolt
7	153004	2	3/8" Flat Washer
8	153004	2	3/8" Flat Washer
9	153005	2	3/8" Lock Washer
10	152005	2	3/8-16 Hex Nut
11	154326	2	5/16-24 x 3/8" Setscrew
12	152004	2	5/16-18 Hex Nut
13	150621	2	5/16-18 x 1-1/2" Tap Bolt
14	153002	4	5/16" Lock Washer
15	153004	6	3/8" Flat Washer
16	150501	4	5/16-18 x 3/4" Tap Bolt
17	102120	1	Sintered 8 Magnet
18	883386	1	Rotational Sensor Assembly
19	100724	1	Shaft Key
20	101100	1	18" Pulley
21	100100	1	5L-660 V-Belt (basket [tumbler] to idler)
22	150610	2	5/16-18 x 1-1/2 Allen Setscrew
23	152004	2	5/16-18 Hex Nut

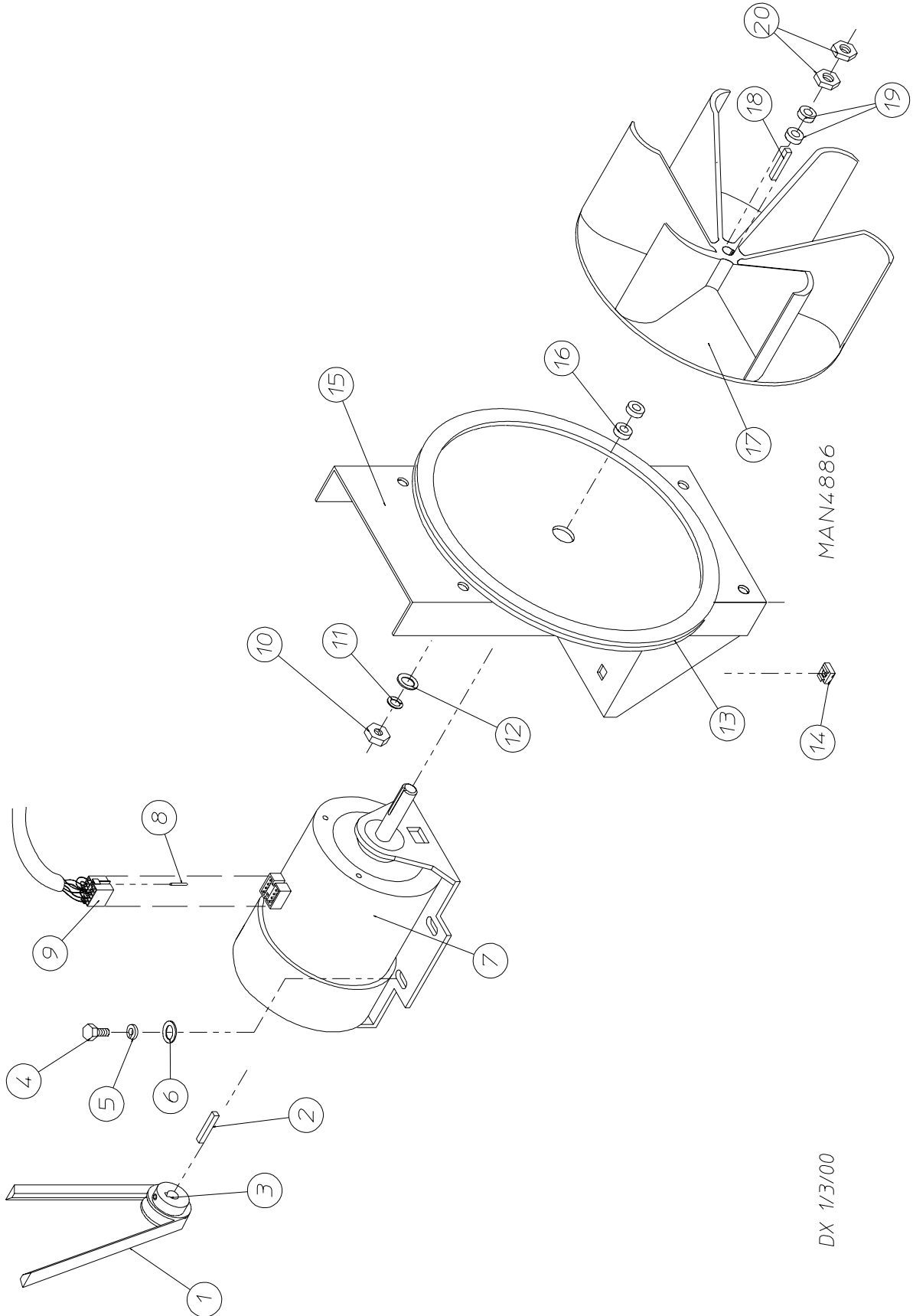

<u>Illus. No.</u>	<u>Part No.</u>	<u>Qty.</u>	<u>Description</u>
1	100105	1	4L-520 V-Belt (idler to motor)
2	100705	1	3/16" x 3/16" x 1-3/8" Key
3	101131	1	1/2" x 2-1/4" Motor Pulley (for models mfd. as of August 22, 2002)
	101133	1	5/8" x 2-1/4" Motor Pulley (for models mfd. prior to August 22, 2002)
4	150501	4	5/16-18 x 3/4" Tap Bolt
5	153002	4	5/16" Lock Washer
6	153001	4	5/16" Flat Washer
7	181049	1	1/2 HP 240v 1 ϕ 50 Hz Motor with Plug (for models mfd. as of August 22, 2002)
	100066	1	1/2 HP 240v 1 ϕ 50 Hz Totally Enclosed, Fan-Cooled (T.E.F.C.) Motor with Plug (for models mfd. prior to August 22, 2002)
8	122701	8	Socket Terminal ONLY
	122801	1	Pin/Socket Extraction Tool
9	137030	1	8-Pin Housing Connector
10	152004	4	5/16-18 Hex Nut
11	153002	4	5/16" Lock Washer
12	153001	4	5/16" Flat Washer
13	117600	4	Noise Suppressor Tape (sold by the foot)
14	154000	4	5/16-18 Tinnerman Nut
15	850017	1	Motor Mount ONLY (56Z frame)
	803813	1	1/2 HP 240v 1 ϕ 50 Hz Totally Enclosed, Fan-Cooled (T.E.F.C.) Motor Mount Assembly Complete with Plug Motor (includes illus. nos. 2 through 7 and 13 through 20)
16	153050	2	1/2" S.A.E. Flat Washer
17	100604	1	12-1/2" Impellor with 1/2" Bore
18	100702	1	1/8" x 1/8" x 1-1/2" Key
19	153050	2	1/2" S.A.E. Flat Washer
20	152006	2	1/2-20 Left Hand Jam Nut

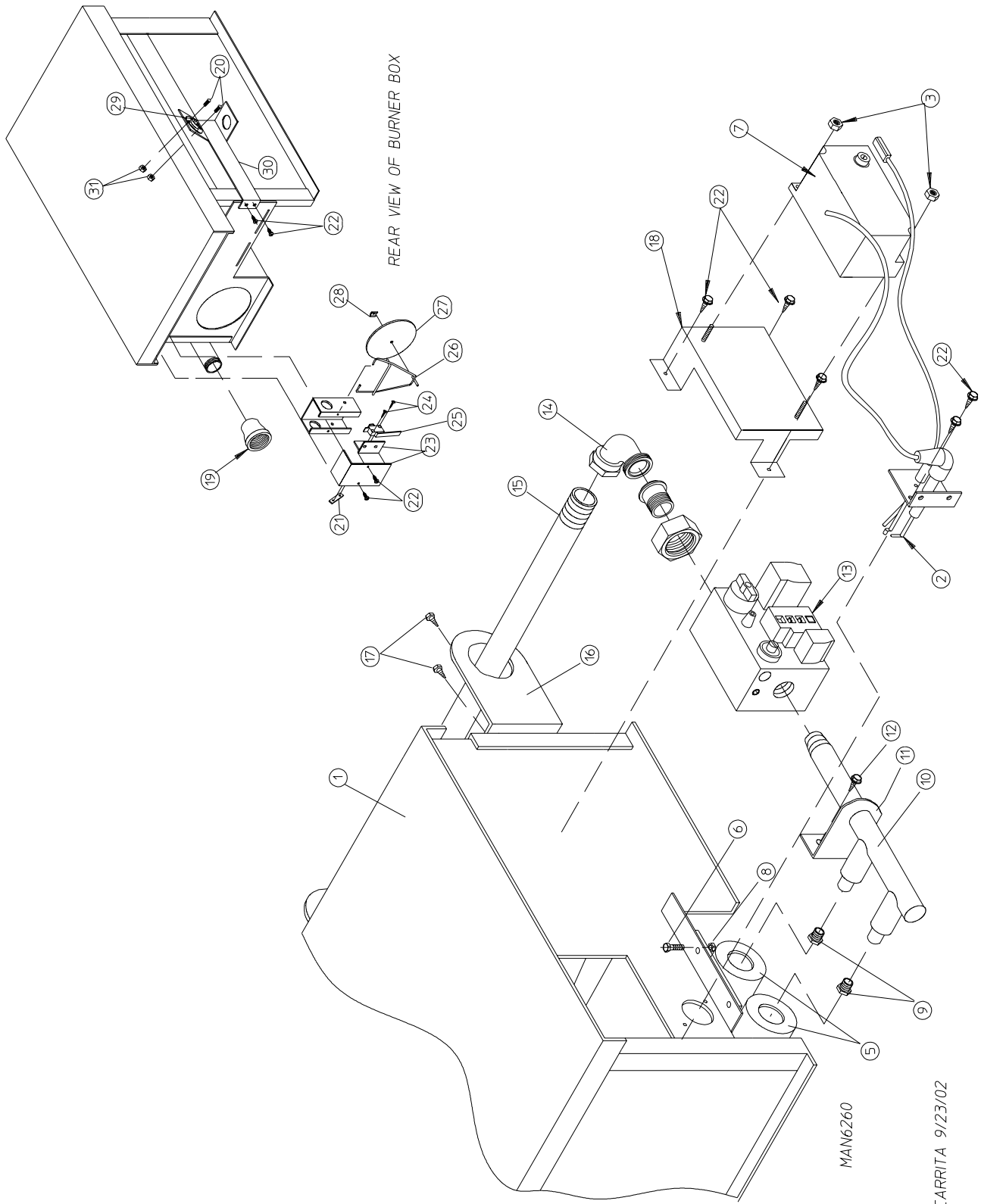

<u>Illus. No.</u>	<u>Part No.</u>	<u>Qty.</u>	<u>Description</u>
1	850858	1	Direct Spark Ignition (DSI) Burner Box ONLY
	801190**	1	Natural Gas Burner Assembly (includes illus. nos. 1 through 8 and 10 through 31)
	817208**	1	Liquid Propane (L.P.) Gas Burner Assembly (includes illus. nos. 1 through 8 and 10 through 31)
	883283	1	D-40 Liquid Propane (L.P.) Conversion Kit
2	809307	1	Ignitor Probe Assembly
3	152013	2	#6-32 Hex Nut
4	150309	5	#10-16 x 1/2" Hex Head TEK Crimptite Screw
5	141105	2	Large Tube Burner
6	150108	2	#8-32 x 1/2" Pan Head Machine Screw
7	128941	1	ADC CE Direct Spark Ignition (DSI) Module (3 tries)
8	151001	2	#8-32 Pal Nut
9	140804*	2	#48 Burner Orifice (liquid propane [L.P.] gas)
	140819*	2	#30 Burner Orifice (natural gas)
10	141230	1	1/2" Direct Spark Ignition (DSI) Manifold (2-port)
11	318700	1	Pipe Bracket (bent)
12	150300	2	#10-16 x 1/2" Hex Washer TEK Screw
13	128933	1	1/2" 24 VAC CE Gas Valve (natural gas)
	883255	1	1/2" 24 VAC CE Gas Valve (liquid propane [L.P.] gas)
14	141317	1	1/2" Bronze Union Elbow
15	142809	1	1/2" x 29-1/8" Pipe
16	318700	2	Pipe Bracket (bent)
17	150309	4	#10-16 x 1/2" Hex Head TEK Crimptite Screw
18	817027	1	Direct Spark Ignition (DSI) Module Mounting Bracket
19	142935	1	1/2" BSPT x 1/2" N.P.T. Transition Coupling
20	150005	2	#6-32 x 1/4" Round Head Machine Screw
21	154004	1	Twin Speed Nut
22	150300	9	#10-16 x 1/2" Hex Washer TEK Screw
23	802799	1	Sail Switch Top and Switch Bracket
24	150303	2	#4 x 3/4" Pan Head "A" Machine Screw
25	122200	1	SPST Sail Switch
26	105500	1	Sail Switch Actuator Rod
27	319202	1	Sail Switch Damper (flat)
28	154002	1	1/8" Push On Fastener
29	130201	1	330° Hi-Limit Manual Reset
30	319704	1	Hi-Limit Mounting Bracket
31	152013	2	#6-32 Hex Nut

* Consult factory for elevations over 2,000 feet.

** Burner orifices *are not included* and **must be** ordered separately.

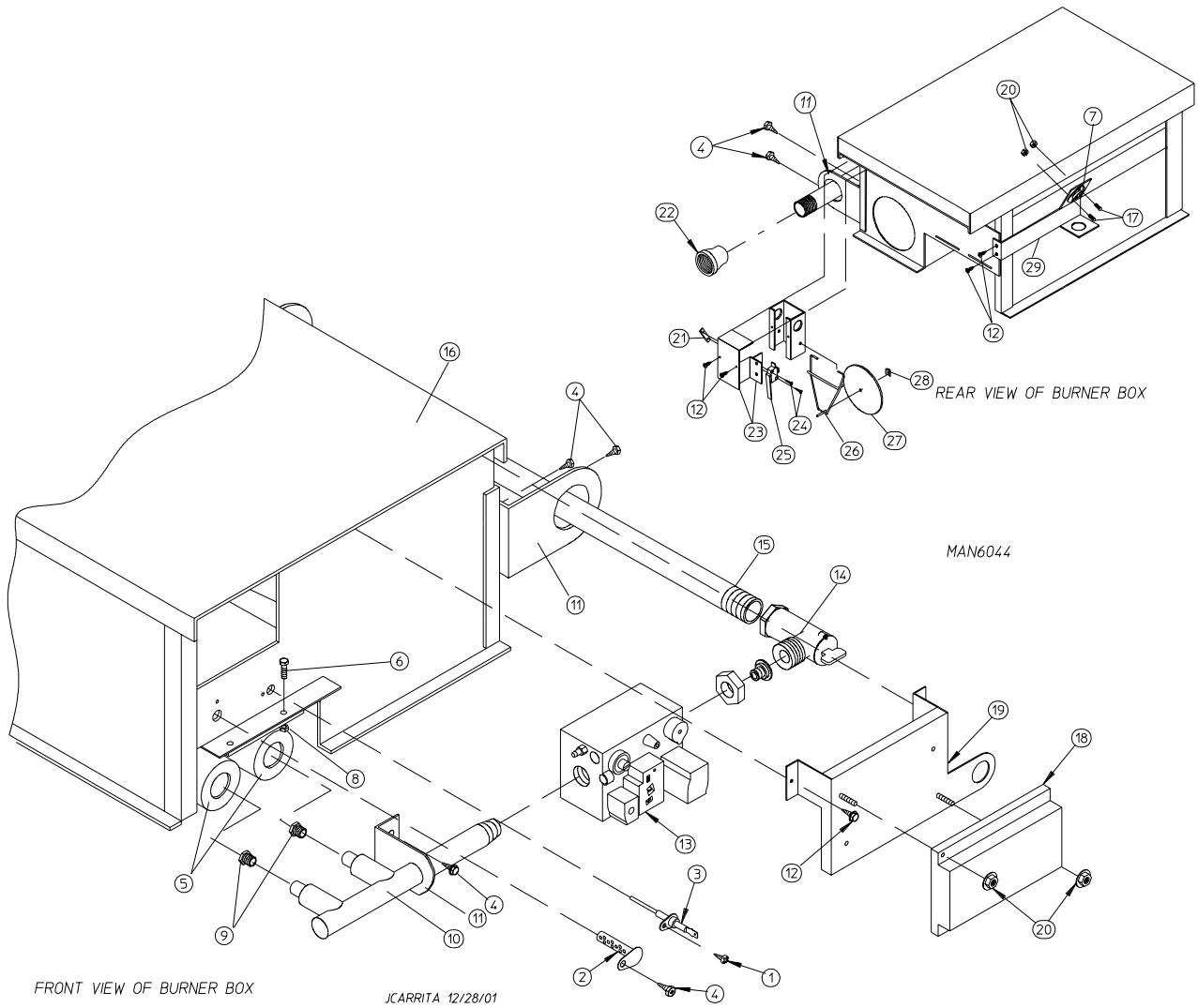

<u>Illus. No.</u>	<u>Part No.</u>	<u>Qty.</u>	<u>Description</u>
1	150301	1	#8-18 x 7/16" Phillips Pan Head TEK Screw
2	128920	1	Hot Surface Ignitor (HSI) 24V 2-1/2" Long
3	128921	1	Hot Surface Ignition (HSI) Flame Sensor
4	150309	7	#10-16 x 1/2" Hex Head TEK Crimptite Screw
5	141105	2	Large Tube Burner
6	150108	2	#8-32 x 1/2" Pan Head Machine Screw
7	130201	1	330° Hi-Limit with Manual Reset
8	151001	2	#8-32 Pal Nut
9	140820*	2	#29 Burner Orifice (natural gas)
	140804*	2	#48 Burner Orifice (liquid propane [L.P.] gas)
10	141230	1	1/2" Direct Spark Ignition (DSI) Manifold (2-port)
11	318700	3	Pipe Bracket (bent)
12	150300	7	#10-16 x 1/2" Hex Washer TEK Screw
13	128933	1	CE Gas Valve
	883255	1	CE 1/2" Liquid Propane (L.P.) Gas Valve
14	141314	1	90° x 1/2" x 1-1/2" Gas Shutoff Assembly
15	142809	1	1/2" x 29-1/8" Pipe
16	850896	1	Hot Surface Ignition (HSI) Burner Box ONLY
	817066**	1	Hot Surface Ignition (HSI) Burner Assembly (natural gas)
	817067**	1	Hot Surface Ignition (HSI) Burner Assembly (liquid propane [L.P.] gas)
	883283	1	D-40 Liquid Propane (L.P.) Conversion Kit
	882603***	1	Steam to Gas Interface Plate
17	150001	2	Round Head Machine Screw
18	128975	1	CE Hot Surface Ignition (HSI) Module
19	810029	1	Hot Surface Ignition (HSI) Module Mounting Bracket Assembly
20	151000	4	#6-32 Pal Nut
21	154004	1	Twin Speed Nut
22	142935	1	1/2" BSPT x 1/2" N.P.T. Transition Coupling
23	802799	1	Sail Switch Top and Switch Bracket
24	150303	2	#4 x 3/4" Pan Head "A" Machine Screw
25	122200	1	SPST Sail Switch
26	105500	1	Sail Switch Actuator Rod
27	319202	1	Sail Switch Damper (flat)
28	154002	1	1/8" Push On Fastener
29	319704	1	Hi-Limit Mounting Bracket

* Consult factory for elevations over 2,000 feet.

** Burner orifices *are not included* and **must be** ordered separately.

*** Needed when converting steam heat to gas heat.

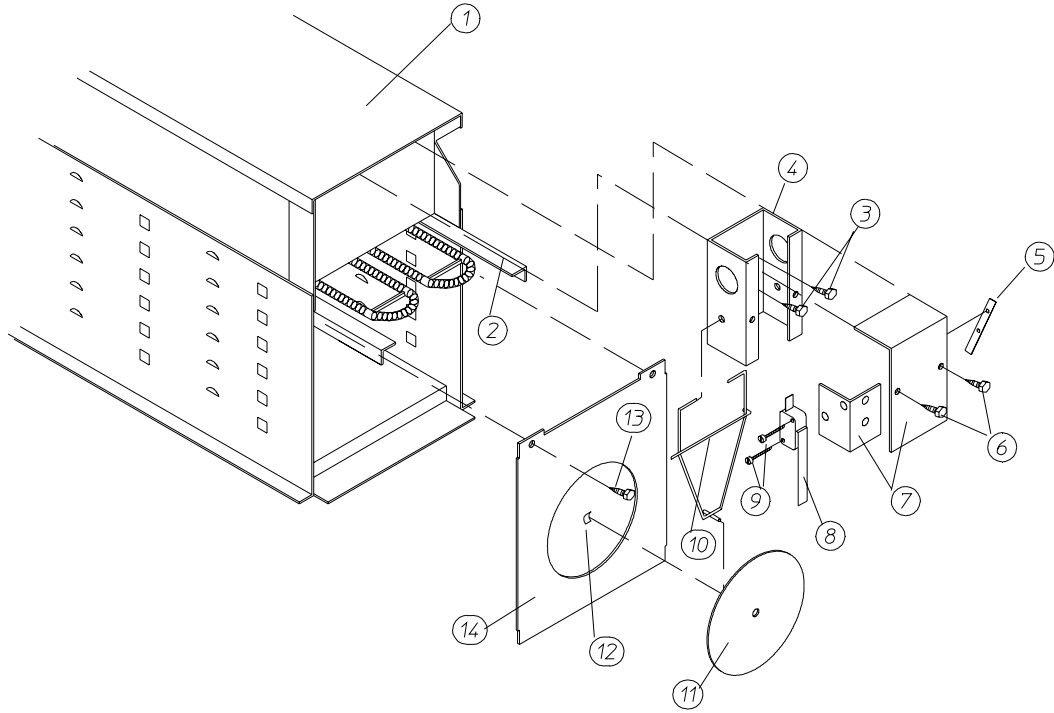

ELECTRIC OVEN (FRONT VIEW)

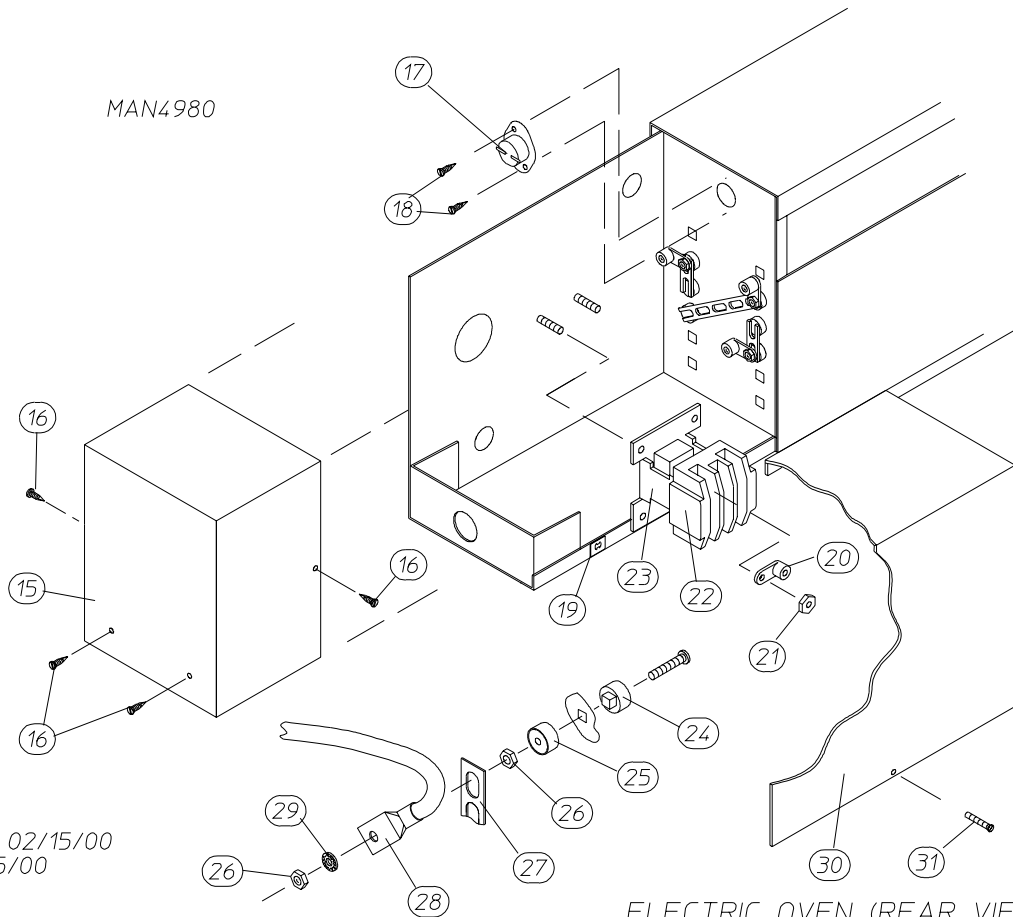

MAN4980

TCOSTA 02/15/00
DX 01/25/00

ELECTRIC OVEN (REAR VIEW)

<u>Illus. No.</u>	<u>Part No.</u>	<u>Qty.</u>	<u>Description</u>
1*	803007	1	Large Electric Oven Box ONLY
	-----	1	Electric Oven Assembly Complete
2*	-----	-	Electric Element
3	150300	2	#10-16 x 1/2" Hex Washer TEK Screw
4	802800	1	Sail Switch Box with Bracket and Cover ONLY
	802801	1	Sail Switch Box Assembly Complete (includes illus. nos. 4 through 12)
5	154004	1	Twin Speed Nut
6	150300	2	#10-16 x 1/2" Hex Washer TEK Screw
7	802799	1	Sail Switch Box Cover and Bracket ONLY
8	122200	1	Sail Switch ONLY
9	150303	2	#4 x 3/4" Phillips Pan Head "A" Machine Screw
10	105500	1	Sail Switch Actuator Rod
11	319202	1	Sail Switch Damper (flat)
12	154002	1	1/8" Push On Fastener
13	150300	2	#10-16 x 1/2" Hex Washer TEK Screw
14	803100	1	Electric Oven Front Cover ONLY
15	320611	1	Large Relay Box Cover ONLY
16	150301	3	#8-18 x 7/16" Phillips Pan Head TEK Screw
17	130400	1	290° Hi-Limit Thermostat
18	150300	2	#10-16 x 1/2" Hex Washer TEK Screw
19	154001	1	#10-24 Speed Nut
20	121010	1	L-70 Ground Lug
21	152014	3	1/4-20 Free Spin Wash Nut
22	-----*	1	Oven Relay
23	-----*	1	Oven Relay Replacement Coil
24	120081	-	Internal Ceramic Insulator (2 per element)
25	120080	-	External Ceramic Insulator (2 per element)
26	152008	-	#10-32 Hex Nut (4 per element)
27	121011	-	Bus Bar (sold by the foot)
28	-----*	-	Oven Wire with Crimp Lug
29	153009	-	#10 Star Washer (2 per element)
30	321301	1	Large Electric Oven Right Side Cover ONLY
31	150402	1	#10-24 x 5/8" Truss Head Machine Screw
--	882603**	1	Steam to Electric Transition Plate

* Refer to **Electrical Oven Component Application Chart** on **page 33**.

** Not illustrated...needed to convert dryer from steam to electric.

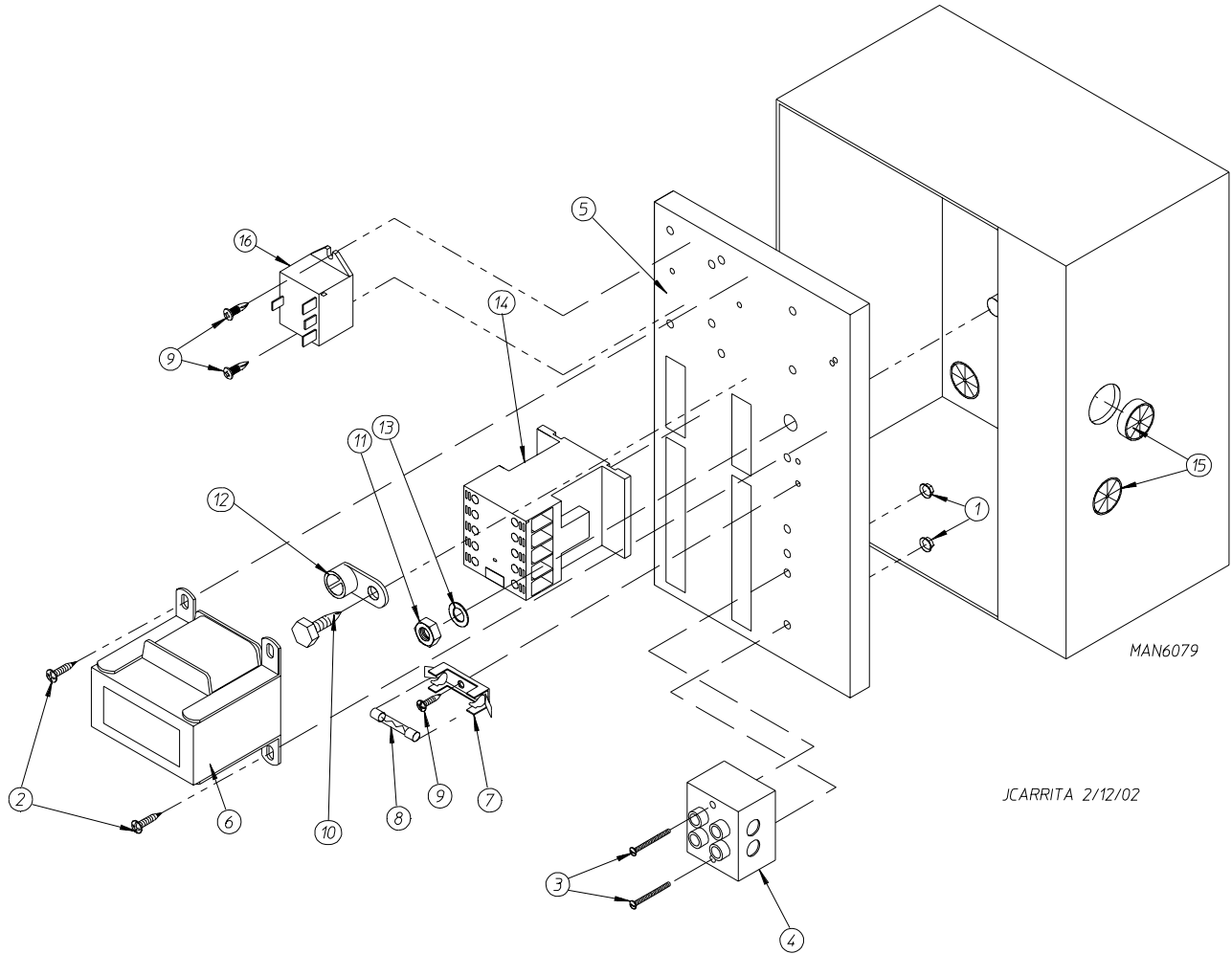

<u>Illus. No.</u>	<u>Part No.</u>	<u>Qty.</u>	<u>Description</u>
1	151000	2	#6-32 Pal Nut
2	150300	2	#10-16 x 1/2" Hex Washer TEK Screw
3	150008	2	#6-32 x 1-1/4" Phillips Pan Head Machine Screw
4	120716	1	2-Position Terminal Block
5	322812	1	Rear Electric Mounting Plate ONLY
	822798	1	Rear Electric Panel Assembly Complete - 230 Volt 1ø For Gas Models ONLY (includes illus. nos. 1 through 14)
	830273	1	Rear Electric Panel Assembly Complete - 230 Volt 1ø For Steam Models (includes illus. nos. 1 through 14)
	830426	1	Rear Electric Panel Assembly Complete - 415 Volt 3ø with 1ø Motor For Electric Models (includes illus. nos. 1 through 14 and 16)
6	822799	1	Transformer Assembly - 230 Volt 1ø
	830141	1	Transformer Assembly - 415 Volt 3ø
7	136008	2	Fuse Holder ONLY
8	136057	2	1/2-Amp (Slo-Blo) Fuse ONLY
9	150301	4	#8-18 x 7/16" Phillips Pan Head TEK Screw
10	150297	1	#10 x 1/2" Green Hex Washer TEK Screw
11	152004	1	5/16-18 Hex Nut
12	121010	1	L-70 Ground Lug
13	153002	1	5/16" Lock Washer
14	132495	1	3-Pole Contactor
15	121300	3	Open/Closed Bushing
16	131932	1	24V SPST Relay (for electric heated models Only)

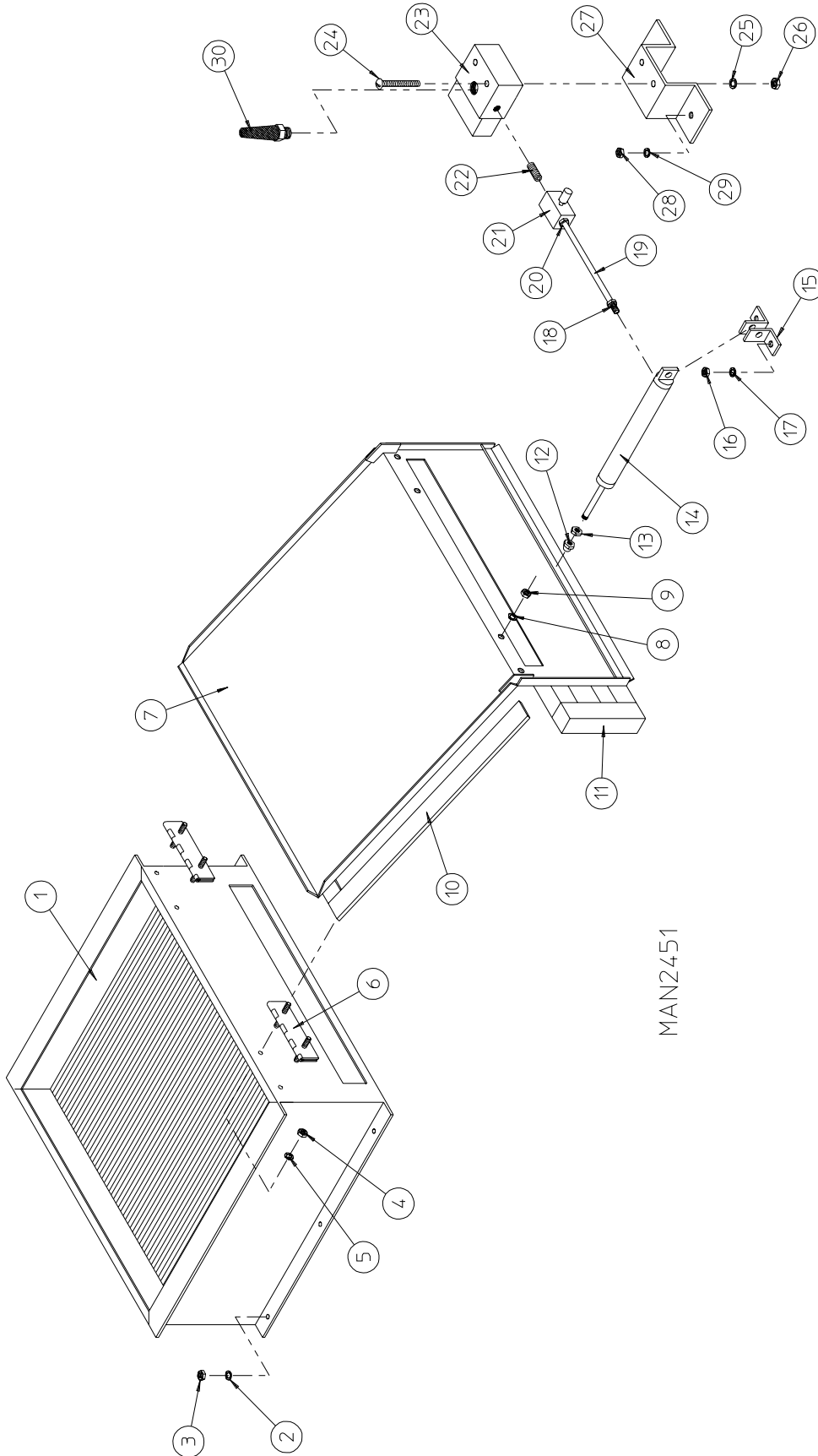

MAN2451

<u>Illus. No.</u>	<u>Part No.</u>	<u>Qty.</u>	<u>Description</u>
1	165008	1	Steam Coil Assembly
2	153002	6	5/16" Lock Washer
3	152004	6	5/16-18 Hex Nut
4	152002	4	1/4-20 Hex Nut
5	153007	4	1/4" Lock Washer
6	820321	2	Steam Damper Hinge Assembly
7	803416	1	Steam Damper Assembly (includes illus. nos. 7, 10, and 11)
8	153007	4	1/4" Lock Washer
9	152002	4	1/4-20 Hex Nut
10	115995	60	Steam Damper Gasket (sold by the inch)
11	102350	1	Steam Damper Foam (68-1/2" length)
12	151006	1	5/16-24 Stainless Steel Acorn Nut
13	152051	1	5/16-24 Right Hand Jam Nut
14	100495	1	11/16" Diagram x 3" Stroke Piston
15	323365	2	Left and Right Piston Support
16	152002	2	1/4-20 Hex Nut
17	153007	2	1/4" Lock Washer
18	100472	1	1/4" x 1/8" Connector
19	143110	1	1/4" Tubing (sold by the foot)
20	100472	1	1/4" x 1/8" Connector
21	100496	1	1/8" Needle Valve
22	143238	1	1/8" Close Nipple
23	100498	1	3-Way Micro Valve - 24 VAC
24	150002	2	#6-32 x 1" Slotted Machine Screw
25	153010	2	#6 Star Washer
26	152000	2	#6-32 Hex Nut
27	330987	1	Micro Valve Support Bracket
28	152002	2	1/4-20 Hex Nut
29	153007	2	1/4" Lock Washer
30	100520	1	1/8" N.P.T. Silencer (muffler)

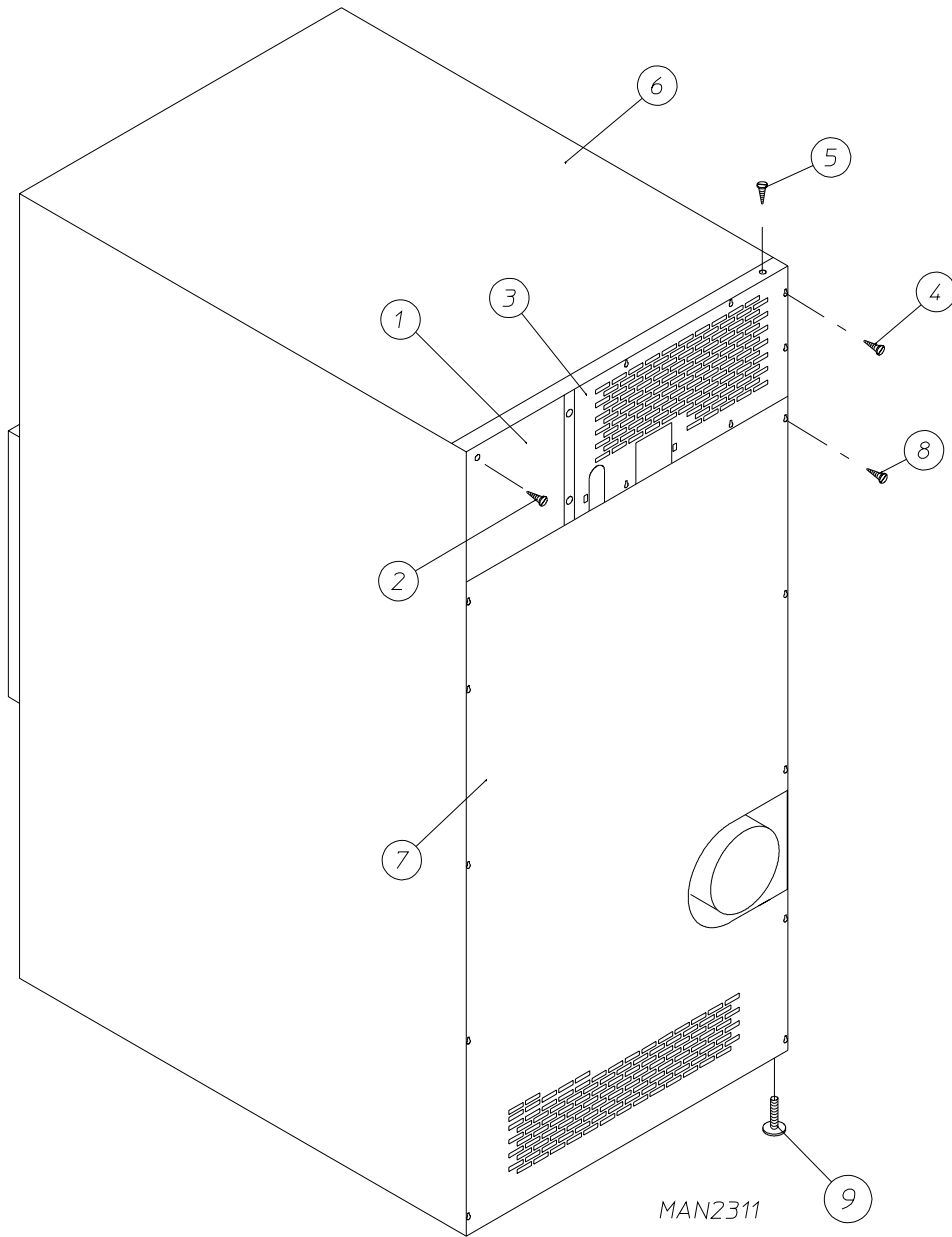

<u>Illus. No.</u>	<u>Part No.</u>	<u>Qty.</u>	<u>Description</u>
1	322809	1	Back Electrical Box Cover
2	150301	4	#8-18 x 7/16" Phillips Pan Head TEK Screw
3*	314424	1	Gas Top Back Guard
	314422	1	Electric Top Back Guard
4	150301	7	#8-18 x 7/16" Phillips Pan Head TEK Screw
5	150300	10	#10-16 x 1/2" Hex Washer TEK Screw
6*	322015	1	Outer Top
7	322082	1	"Plain" Bottom Back Guard
8	150301	13	#8-18 x 7/16" Phillips Pan Head TEK Screw
9	103500	4	Leveling Leg

* There is no outer top or top back guard on steam models.

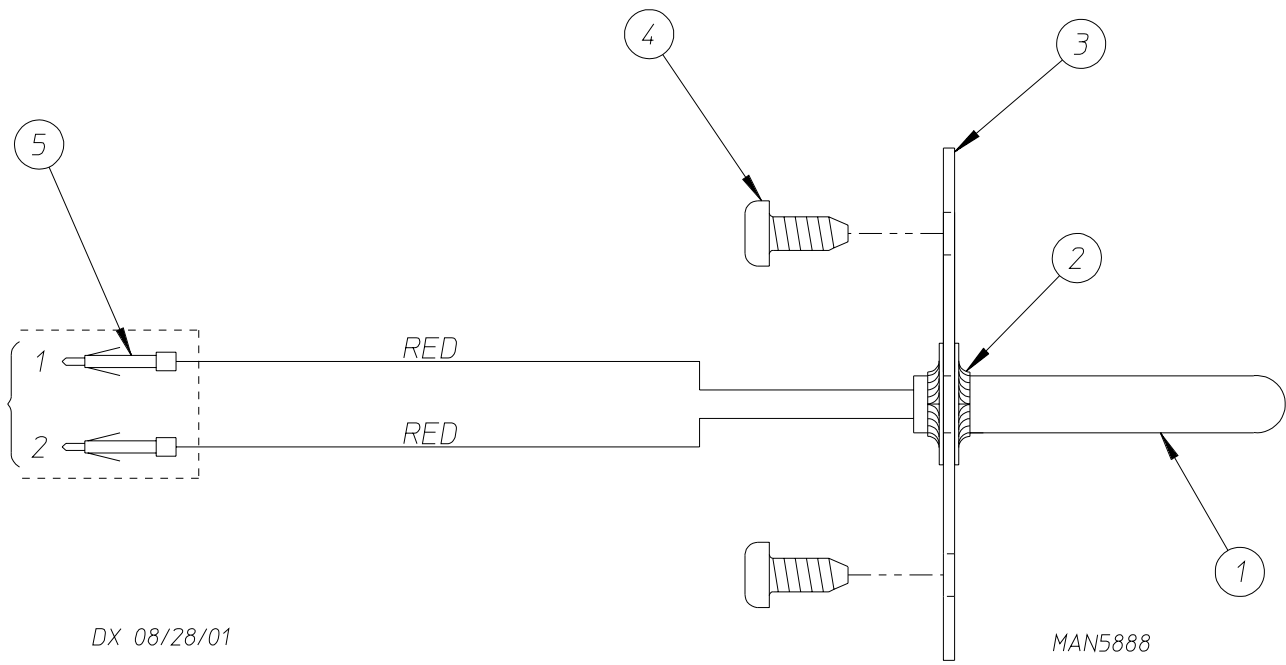

<u>Illus. No.</u>	<u>Part No.</u>	<u>Qty.</u>	<u>Description</u>
1	822752	1	S.A.F.E. Temperature Probe Assembly (includes illus. nos. 1 through 5)
2	154007	2	Push On Fastener
3	390390	1	Sensor Bracket ONLY
4	150301	2	#8-18 Phillips Pan Head TEK Screw
5	122647	1	Connector ONLY

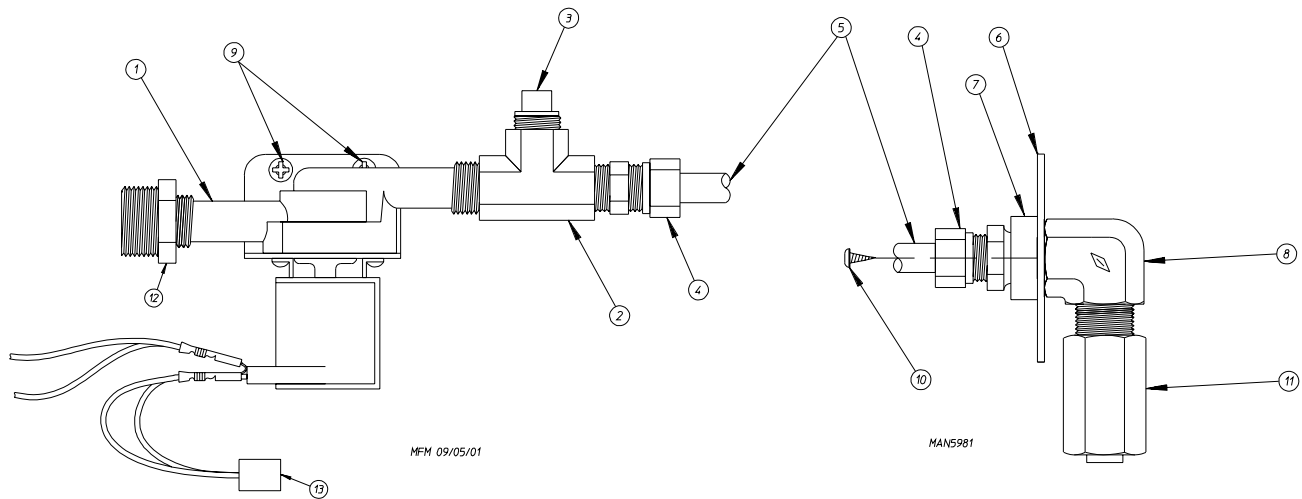

<u>Illus. No.</u>	<u>Part No.</u>	<u>Qty.</u>	<u>Description</u>
1	165114	1	S.A.F.E. Solenoid Valve 24V 50/60 HZ
2	143220	1	3/8" F.P.T. Brass Tee
3	143251	1	3/8" M.P.T. Brass Plug
4	143208	2	3/8" Comp x 3/8" M.P.T. Brass Connector
5	143099*	6'	3/8" OD x 0.035 Wall Copper Tubing
6	311588	1	Sprinkler Head Mounting Plate
7	143303	1	3/8" N.P.T. Brass Locknut
8	143155	1	3/8" Brass Street Elbow 90°
9	150430	2	#10 x 1/2" Self Drilling Screw
10	150301	2	#8-18 x 7/16" TEK Screw
11	143581	1	3 GPM 3/8" F.P.T. Spray Nozzle
12	142887	1	3/4" to 3/8" Bushing for Fire Suppression System (FSS) Valve
13	824081	1	R.C. Network Assembly

* Sold by the foot.

Kw	Voltage	Phase	Wire	Oven Assembly*	Element			Oven Wire with Crimp Terminal			Terminal Lug		Bus Bar P/N: 121011	Oven Relay	
					Qty.	Kw	Part No.	Qty.	Size	Part No.	Qty.	Part No.		Cat. No.	Part No.
24	415	3Ø	3 or 4	846957	6	4	120011	1	#8	882571	1	121010	1	DPA33	131352

* When ordering Oven Assembly Complete, specify 3 or 4 wire when applicable as well as if dryer has Microprocessor controls.

<u>Part No.</u>	<u>Description</u>
114006	“WARNING - Fire Hazards” Label
112280	“Clean Lint Screen” Label
114001	“CAUTION - Exhaust/Lint Screen” Label
114521	“Phase 7 OPL Program Location Summary” Label
120100	3/8” Straight (BX) Connector
120300	3/8” x 45° (BX) Connector
120400	3/8” Red Jacket (BX) Insulator
120500	3/8” Jiffy Clip (BX retainer clip)
120600	3/8” Greenfield (BX)
120707	(2-Position) Terminal Strip
120708	(3-Position) Terminal Strip
120800	1/4” In-Line Connector
120802	Red Butt Connector
120902	#74B Wire Nut
120903	Crimp-On Wire Nut
121014	1/4” Insulated (female) Terminal
121026	Tab Receptacle Combination
121499	5-1/2” Harness Tie
121500	8” Harness Tie
122804	Manometer (hydro gauge) for Measuring Gas Pressure
404502	White Brush-In-Cap Bottle Touch-Up Paint
