



150 lb. Laundry Dryer

MODELS

GAS

L50CD42G

L50KD42G

STEAM

L50CD42S

L50KD42S

OWNER'S MANUAL

CISSELL MANUFACTURING COMPANY

U.S. HEADQUARTERS

831 SOUTH FIRST ST.

P.O. BOX 32270

LOUISVILLE, KY

40203-2270

PHONE: (502) 587-1292

FAX: (502) 585-3625

PARTS EXPRESS: 1-800-882-6665

EUROPEAN HEADQUARTERS

PANTEX/CISSELL B.V.

INDUSTRIEWEG 27

P.O. BOX 53

9670 AB WINSCHOTEN

THE NETHERLANDS

PHONE: (05970) 12300

FAX: (05970) 12723

MAN173 12/91

IMPORTANT NOTICES - PLEASE READ

For optimum efficiency and safety, we recommend that you read the Owner's Manual before operating the equipment. Store this manual in a file or binder and keep for future reference.

WARNING: For your safety, the information in this manual must be followed to minimize the risk of fire or explosion or to prevent property damage, personal injury, or loss of life.

Do not store or use gasoline or other flammable liquids or vapors in the vicinity of this or any other appliance.

WHAT TO DO IF YOU SMELL GAS

- Do not try to light any appliances.
- Do not touch any electrical switch; do not use any phone in the building.
- Clear the room, building, or area of all occupants.
- Immediately call your gas supplier from a neighbor's phone. Follow the gas supplier's instructions.
- If you cannot reach the gas supplier, call the Fire Department.

Installation and service must be performed by a qualified installer, service agency, or the gas supplier.

WARNING

This dryer must be used only to dry water-washed fabrics.

To avoid fire hazard, do not dry articles containing foam rubber or similar textured materials. Do not put into this dryer flammable items such as baby bed mattresses, throw rugs, undergarments (brassieres, etc.) and other items which use rubber as padding or backing. Rubber easily oxidizes causing excessive heat and possible fire. These items should be air dried.

In the event the user smells gas odor, instructions on what to do must be posted in a prominent location. This information can be obtained from the local gas supplier.

Note: Purchaser must post the following notice in a prominent location:

FOR YOUR SAFETY
DO NOT STORE OR USE GASOLINE OR OTHER FLAMMABLE VAPORS
AND LIQUIDS IN THE VICINITY OF THIS OR ANY OTHER APPLIANCE.

A clothes dryer produces combustible lint and should be exhausted outside the building. The dryer and the area around the dryer should be kept free of lint.

Be safe, before servicing machine the main power should be shut off.

Synthetic solvent fumes from drycleaning machines create acids when drawn through the dryer. These fumes cause rusting of painted parts, pitting of bright or plated parts, and completely removes the zinc from galvanized parts, such as the tumbler basket. If drycleaning machines are in the same area as the tumbler, the tumbler's make-up air must come from a source free of solvent fumes.

CISSELL DRYER WARRANTY

The Cissell Manufacturing Company (Cissell) warrants all new equipment (and the original parts thereof) to be free from defects in material or workmanship for a period of two (2) years from the date of sale thereof to an original purchaser for use, except as hereinafter provided. With respect to non-durable parts normally requiring replacement in less than two (2) years due to normal wear and tear, and with respect to all new repair or replacement parts for Cissell equipment for which the two (2) year warranty period has expired or for all new repair or replacement parts for equipment other than Cissell equipment, the warranty period is limited to ninety (90) days from date of sale. The warranty period on each new replacement part furnished by Cissell in fulfillment of the warranty on new equipment or parts shall be for the unexpired portion of the original warranty period on the part replaced.

With respect to electric motors, coin meters and other accessories furnished with the new equipment, but not manufactured by Cissell, the warranty is limited to that provided by the respective manufacturer.

Cissell's total liability arising out of the manufacture and sale of new equipment and parts, whether under the warranty or caused by Cissell's negligence or otherwise, shall be limited to Cissell repairing or replacing, at its option, any defective equipment or part returned f.o.b. Cissell's factory, transportation prepaid, within the applicable warranty period and found by Cissell to have been defective, and in no event shall Cissell be liable for damages of any kind, whether for any injury to persons or property or for any special or consequential damages. The liability of Cissell does not include furnishing (or paying for) any labor such as that required to service, remove or install; to diagnose troubles; to adjust, remove or replace defective equipment or a part; nor does it include any responsibility for transportation expense which is involved therein.

The warranty of Cissell is contingent upon installation and use of its equipment under normal operating conditions. The warranty is void on equipment or parts; that have been subjected to misuse, accident, or negligent damage; operated under loads, pressures, speeds, electrical connections, plumbing, or conditions other than those specified by Cissell; operated or repaired with other than genuine Cissell replacement parts; damaged by fire, flood, vandalism, or such other causes beyond the control of Cissell; altered or repaired in any way that effects the reliability or detracts from its performance, or; which have had the identification plate, or serial number, altered, defaced, or removed.

No defective equipment or part may be returned to Cissell for repair or replacement without prior written authorization from Cissell. Charges for unauthorized repairs will not be accepted or paid by Cissell.

CISSELL MAKES NO OTHER EXPRESS OR IMPLIED WARRANTY, STATUTORY OR OTHERWISE, CONCERNING THE EQUIPMENT OR PARTS INCLUDING, WITHOUT LIMITATION, A WARRANTY OF FITNESS FOR A PARTICULAR PURPOSE, OR A WARRANTY OF MERCHANTABILITY. THE WARRANTIES GIVEN ABOVE ARE EXPRESSLY IN LIEU OF ALL OTHER WARRANTIES, EXPRESS OR IMPLIED. CISSELL NEITHER ASSUMES, NOR AUTHORIZES ANY PERSON TO ASSUME FOR IT, ANY OTHER WARRANTY OR LIABILITY IN CONNECTION WITH THE MANUFACTURE, USE OR SALE OF ITS EQUIPMENT OR PARTS.

For warranty service, contact the Distributor from whom the Cissell equipment or part was purchased. If the Distributor cannot be reached, contact Cissell.

IDENTIFICATION NAMEPLATE

The Identification Nameplate is located on the rear wall of the dryer. It contains the dryer serial number, product number, model number, electrical specifications and other important data that may be needed when servicing and ordering parts, wiring diagrams, etc. Do not remove this nameplate.

TABLE OF CONTENTS

INSTALLATION

Important Notices and Warnings	1
Warranty	2
Table of Contents	3-4
Unpacking and General Information	5
Outline Dimensions, Gas Models	6
Outline Dimensions, Steam Models	7
Specifications and Motor List	8
Electrical Connections and Grounding Instructions	9
Steam Dryer Installation Instructions	10
Steam Piping Installation and Recommendations	11
Steam Piping Illustration	12
Gas Piping Installation	13
Gas Pipe Size Chart	14
Dryer Installation with Multiple Exhaust	15
Dryer Installation with Separate Exhaust	16
Exhaust Duct Size Chart and Exhaust Booster Fan	17
Dryer Air Flow Installation	18

OPERATION

Two Timer Models Operating Instructions	19
Two Timer Models Control Panel Illustration	20
Burner Air Inlet Shutters Adjustment	21
Automatic Computerized Dryer Control Description and Features	22
Operation of Automatic Computerized Dryer Control Panel	23
Control Panel Illustration, Automatic Computer Dryer Control	24
Control Board Details, Automatic Computer Dryer Control	25
Control Board Illustration, Automatic Computer Dryer Control	26
Rules For Safe Operation	27
Energy Saving Tips, Service Savers	28

SILICON CARBIDE IGNITION SYSTEM

Operation of Ignition System	29-31
Safety Features	31

MAINTENANCE

Lint Trap, Sweep Sheets, Gear Reducer, Pulleys and Belts	34
Electric Motors, Steam Units, Gas Burners, Gas Pressure	34
Exhaust System, Voltage, Combustion Air and Ventilation Air	34
Basket Alignment Instructions	35
Shimming the Basket and Spider Assembly	36
Gear Reducer	37
Air Switch Adjustment	38
Installation of Silicon Carbide Igniter	39
Reversing Control Timer Adjustment	40

ILLUSTRATED PARTS

Reversing Timer	41
Gear Reducer	42
Reversing Control Panel Assembly	43
Overload Heaters Ordering Chart	44
Front View	45-46
Rear View	47-48
Motor Assembly, 50 Cycle Model	49
Front Panel and Door Assembly	50
Automatic Computer Drying Control Box Assembly	51
Permanent Press Control Box Assembly (Two Timer Model)	52
Air Switch Assembly	53
Thermistor Assembly	53
Steam Heating Unit Assembly	54
Gas Heating Unit Assembly	55-56
Basket Sensor Assembly, Automatic Computer Drying	57
Temperature Assembly	58

TROUBLE SHOOTING CHARTS

Basket Motor Runs, But Will Not Revolve, Noisy Dryer, No Heat	59
Dryer Runs But No heat	60
Main Burners Burning Improperly, Gas Problems, Dryer Too Hot	61
Motor Will Not Start, Motor Tripping, Basket Will Not Reverse	62
Dryer Does Not Stop, Steam Unit Problems	63

Note: Information contained in this manual is subject to change without prior notice.

UNPACKING

All Cissell dryers are packed in a protective, heavy-duty plastic bag.

Upon arrival of the equipment, any damage in shipment should be reported to the carrier immediately.

When locating permanent location of unit, care should be taken in movement and placement of equipment. To move dryer through doorways, you may need to remove the top of machine. Follow instructions for disassembling.

See outline clearance drawings for correct dimensions.

Remove all packing material such as tapes, manuals, skid, etc. On gear reducer models, remove screw from air vent and the cork from the oil reserve well.

Check voltage and amperes on rating plate before installing the dryer.

GENERAL INSTALLATION - ALL DRYERS

IMPORTANT: Before installing or operating this dryer, thoroughly read the owner's manual for correct instructions concerning electric connections, exhaust ducting, gas piping, steam connections, make-up air, etc. Read the warnings in this manual. Do not install this dryer in an area where it will be exposed to water and/or weather. Failure to follow these instructions and warnings may create a safety hazard and may affect the warranty. Follow all local codes. If you have any installation questions, consult the factory Service Department.

The construction of Cissell dryers permits installation side by side to save space or to provide a wall arrangement. Position dryer for the least amount of exhaust piping and elbows, and allow free access to the rear of dryer for future servicing of belts, pulleys and motors. Installation clearances from all combustible construction is 0'' ceiling clearance, 0'' rear clearance, and 0'' side clearance.

Before operating dryer, open basket door and remove blocking between front panel and basket. Read all instruction tags, owner's manual, etc.

GENERAL INFORMATION

The Cissell Dryer is so designed that when an operator opens the dryer door, the basket and exhaust fan stop. You can expect fast drying from a Cissell Laundry Dryer. Hot, dry air is properly and effectively moved through basket and exhausted through a lint trap to the atmosphere. The Cissell Dryer comes equipped with an inclined self-cleaning lint screen. In this system, lint accumulates on the underside of the screen until a blanket approximately 1/4" thick is formed. This blanket of lint will fall from the screen to the bottom of the dryer cabinet, and should be removed daily or as required, to prevent an over-accumulation.

IMPORTANT: Provide adequate clearance for air openings into the combustion chamber.

REPLACEMENT PARTS

Replacement parts for this dryer are available from your distributor or by contacting the factory at the address or phone number printed on the cover of this manual.

PROCEDURE FOR DISASSEMBLING THE TOP OF THE DRYER

1. Unscrew 2 front cover panel hold down screws and open the front cover panel. If wires enclosed are not color coded or numbered, mark wires before disconnecting. Refer to wiring diagram.
2. Disconnect the wire plugs in the right and left control boxes. Unscrew the 2 hold down bolts from the bottom of the boxes and one screw from the outside rear of the boxes. Remove the 2 screws that hold the conduit plate to the boxes. Remove the boxes and the top brace as one assembly.
3. Unscrew the 6 bolts that hold down the heating unit.
4. Remove the air switch box cover on the rear of the dryer and disconnect the 8 wires and the box from the rear of the dryer. Leave the air switch fastened to the dryer rear wall.
5. To re-assemble, reverse this procedure.

CISSELL 150 lb. C&K MODELS GAS FIRED DRYER

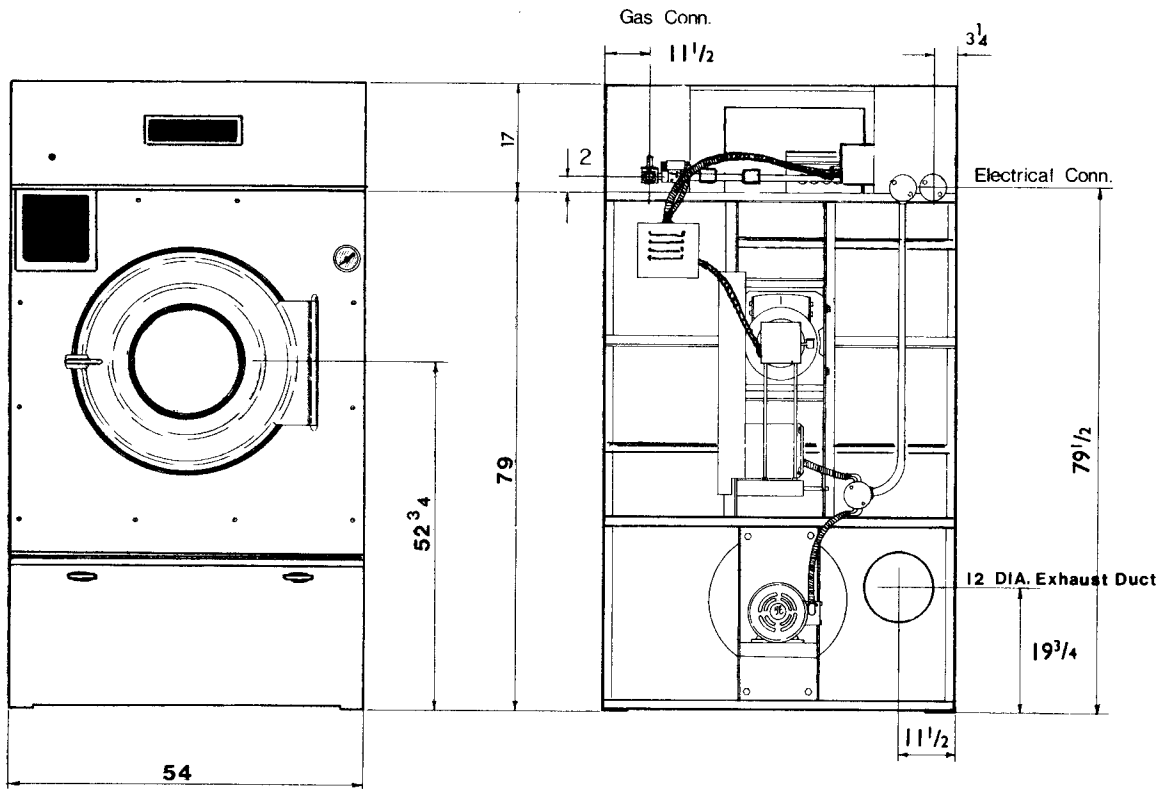

FRONT VIEW

REAR VIEW

ELECTRICAL CONN. BOX IS MOUNTED FLUSH TO DRYER.

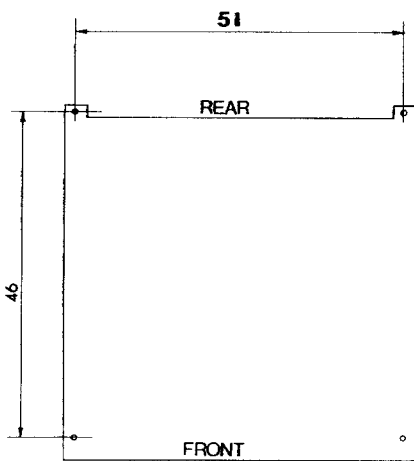

MOUNTING HOLES

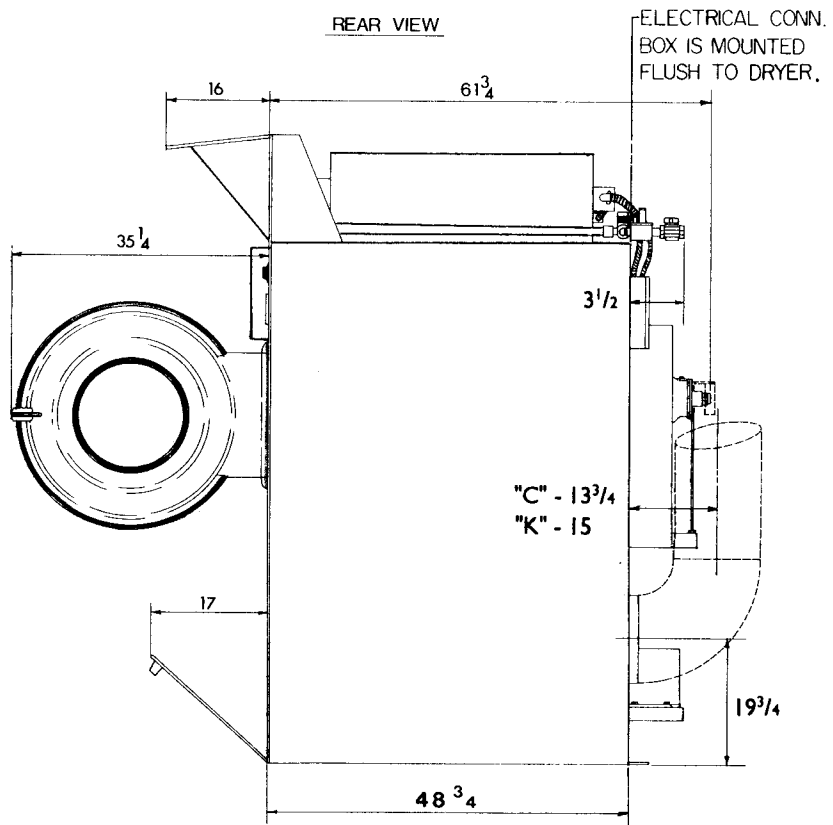

SIDE VIEW

CISSELL 150 lb. STEAM HEATED MODELS

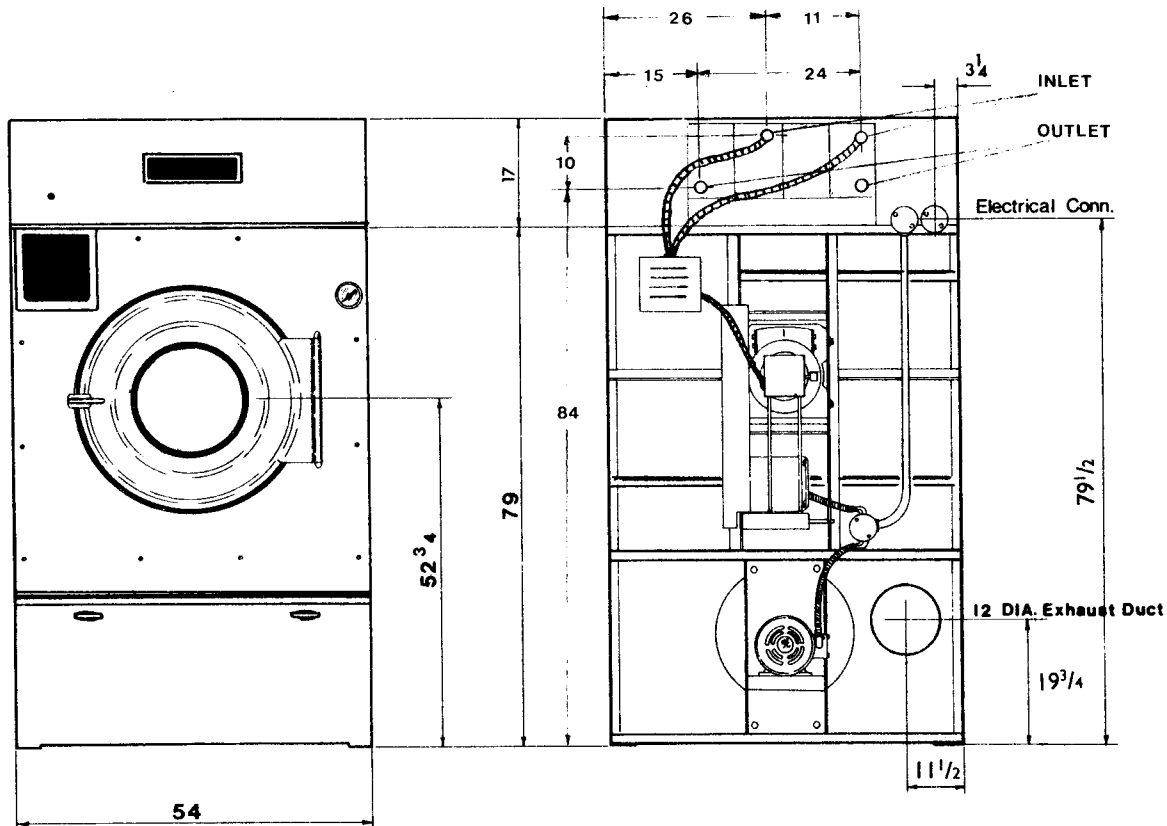

FRONT VIEW

REAR VIEW

ELECTRICAL CONN. BOX IS MOUNTED FLUSH TO DRYER.

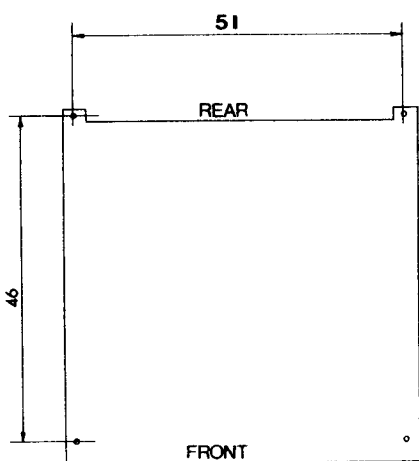

MOUNTING HOLES

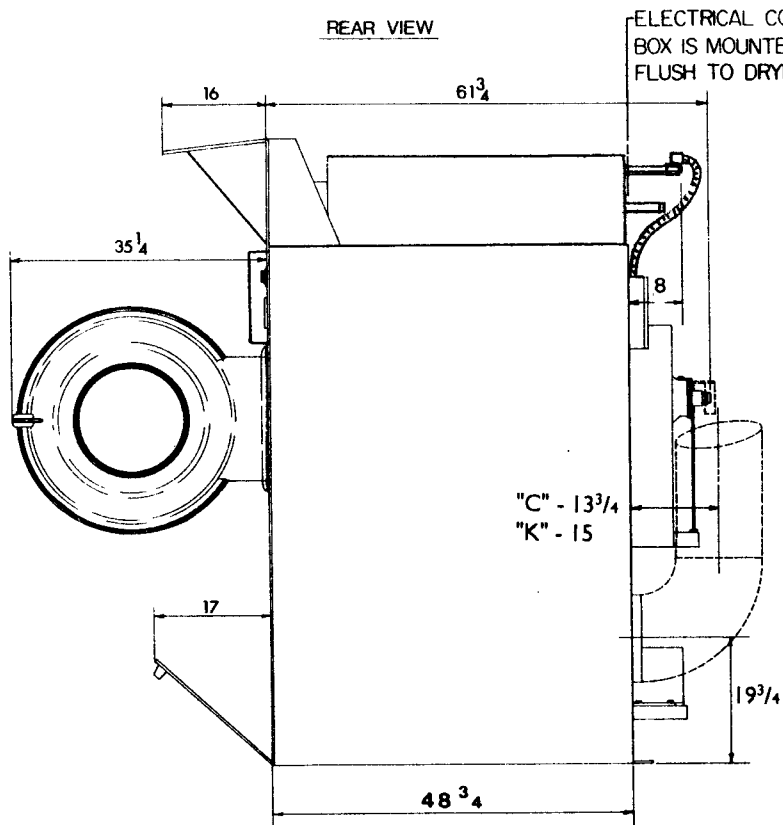

SIDE VIEW

ELECTRICAL CONNECTIONS - ALL DRYERS

Dryers must be electrically grounded - by a separate #14 or larger green wire from the grounding terminal within the service connection box to a cold water pipe. In all cases, the grounding method must comply with local electrical code requirements; or in the absence of local codes, with the National Electrical Code as ANSI/NFPA No. 70-1990.

See wiring diagram furnished with dryer. Your Cissell dryer is completely wired at the factory and it is only necessary for the electrician to connect the power leads to the wire connectors with the service connection box on the rear of the dryer. Do not connect the dryer to any voltage or current other than that specified on the dryer rating plate. (Wiring diagram is located on rear wall of dryer).

All Panels must be in position before operation of dryer.

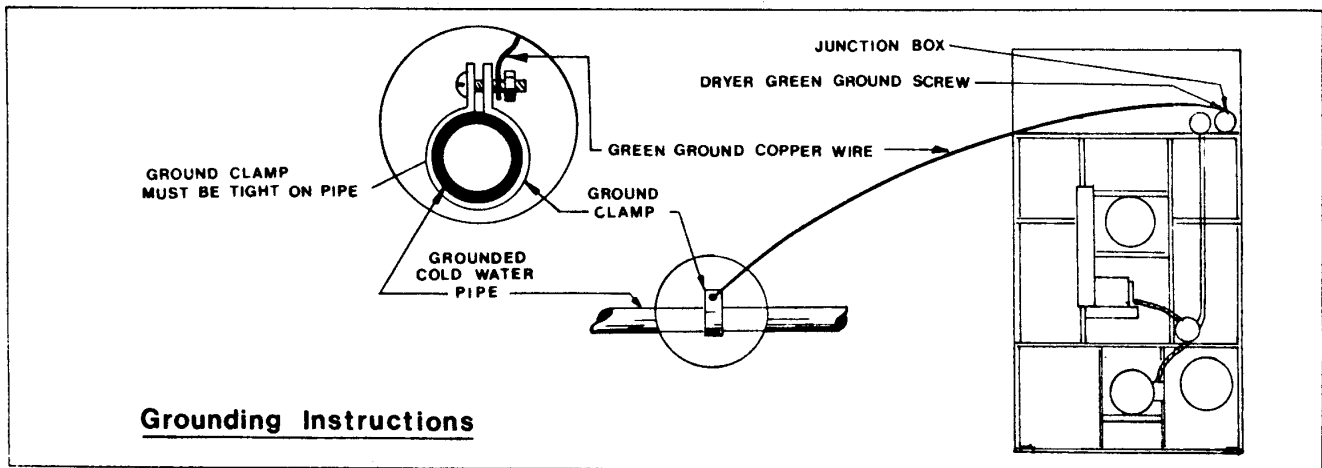

STEAM DRYERS
INSTALLATION INSTRUCTIONS

1. The dryer comes in two wood crates:
 A - Very large crate
 B - Smaller crate
2. Open crate A and lift dryer off the skid and set in place.
3. Open crate B it contains two assemblies:
 I - Control Box Assembly
 II - Steam Bonnet Assembly
4. Place II steam bonnet assembly on top of the dryer and slide piped end to rear of dryer. Bolt to top with six 3/8 bolts, flat washers and lockwashers provided. Attach solenoid conduits(2) to the air switch box then connect the wires as per diagram in box.
5. Place I control box assembly on top front of the dryer and bolt in place with six 3/8 bolts, flat washers and lockwashers. Snap the electrical connections together and attach electrical conduit on left side.
6. Proceed with steam piping, electrical services and duct work as specified in technical manual.

I - Control Box Assembly

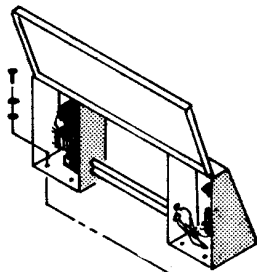

II - Steam Bonnet Assembly

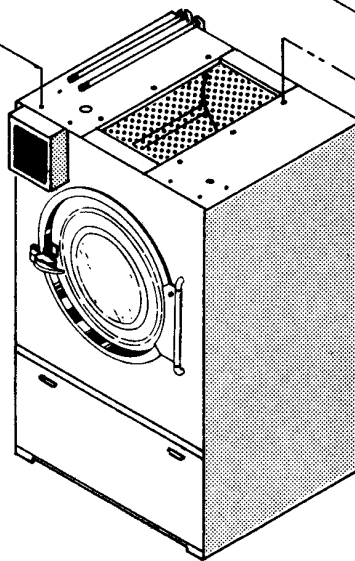
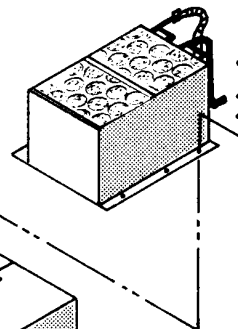

STEAM PIPING INSTALLATION INSTRUCTIONS:

1. Set and anchor dryer in position. Machine should be level to assure proper steam circulation.
2. To prevent condensate draining from headers to dryer, piping should have a minimum 12" above respective header. Do not make steam connection to header with a horizontal or downwardly facing tee or elbow.
3. Whenever possible, horizontal runs of steam lines must drain, by gravity, to respective steam header. Water pockets, or an improperly drained steam header will provide wet steam, causing improper operation of dryer. If pockets or improper drainage cannot be eliminated, install a by-pass trap to drain condensate from the low point in the steam supply header to the return.
4. In both steam supply and steam return line, it is recommended that each have a 3/4" union and 3/4" globe valve. This will enable you to disconnect the steam connections and service the dryer while your plant is in operation.
5. Before connecting trap and check valve to dryer, open globe valve in steam supply line and allow steam to flow through dryer to flush out any dirt and scale from dryer. This will assure proper operation of trap when connected.
6. After flushing system, install bucket trap (w/built in strainer) and check valve. For successful operation of dryer, install trap 18" below coil and as near to the dryer as possible. Inspect trap carefully for inlet and outlet markings and install according to trap manufacturer's instructions. If steam is gravity returned to boiler, omit trap but install check valve in return line near dryer.
7. Install union and globe valve in return line and make final pipe connections to return header.

PIPING RECOMMENDATIONS:

1. Trap each dryer individually. Always keep the trap clean and in good working condition.
2. When dryer is on the end of a line of equipment extend header at least 4 feet beyond dryer. Install globe valve, union, check valve and by-pass trap at end of line. If gravity return to boiler, omit trap.
3. Insulate steam supply and return line for safety of operator and safety while servicing dryer.
4. Keep dryer in good working condition. Repair or replace any worn or defective parts.

STEAM PIPING INSTALLATION

ILLUSTRATION

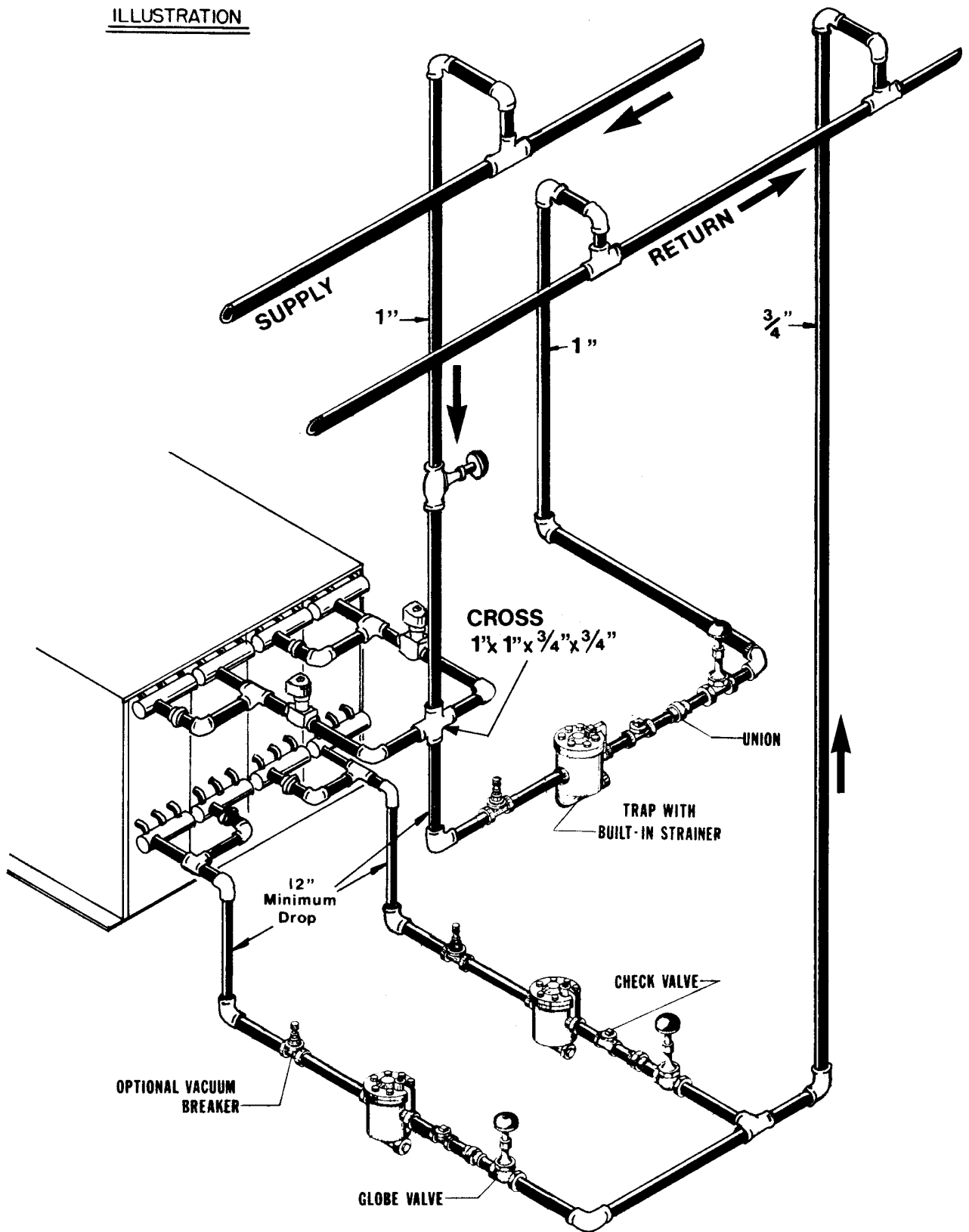

INDIVIDUALLY TRAPPED COILS ARE RECOMMENDED RATHER THAN MANFOLDING
RETURN INTO ONE TRAP

GAS PIPING INSTALLATION

Gas service installation must conform with local codes, or in the absence of local codes, with the National Fuel Gas Code, ANSI Z223.1-1988.

Check Rating Plate located on rear wall of dryer, for type of gas to equip the dryer and the altitude (elevation).

Check with the gas supplier for the gas pressure and the proper gas supply line installation.

NOTE: The dryer and its individual shutoff valve must be disconnected from the gas supply piping system during any pressure testing of that system at test pressures in excess of 1/2 PSIG (3.5 kPa).

The dryer must be isolated from the gas supply piping system by closing its individual manual shutoff valve during any pressure testing of the gas supply piping system at test pressures equal to or less than 1/2 PSIG (3.5 kPa).

CAUTION: Low gas pressure and intermittent gas will cause gas ignition problems. This will cause inadequate drying of the clothes load.

NATURAL GAS ONLY: Check the gas pressure inlet supply to the dryer, 11 inches W.C. pressure maximum. Check the manifold pressure 3.5 inches W.C. pressure inside the dryer.

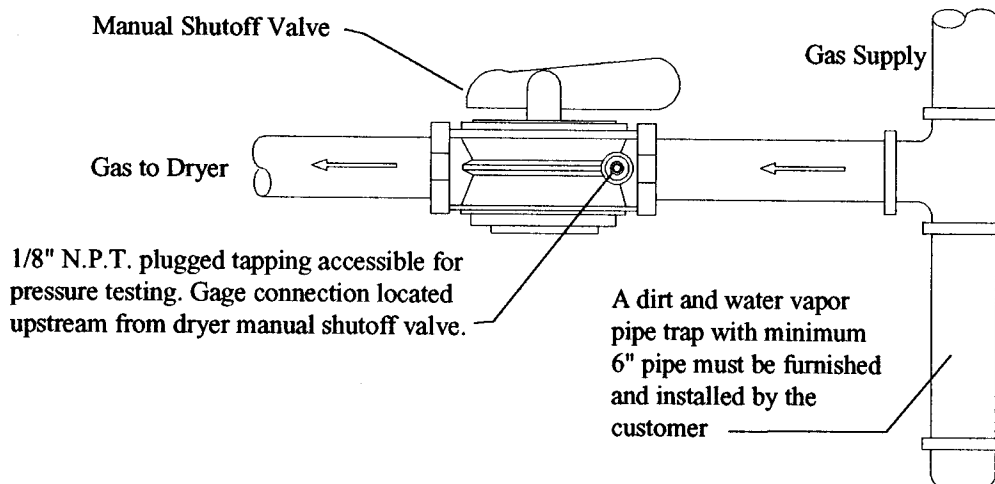

WARNING: LIQUIFIED PETROLEUM GASES ONLY. A Gas Pressure Regulator for liquified petroleum gases is not furnished on Cissell dryers. This regulator is normally furnished by the installer. In accordance with the American Gas Association standards, a gas pressure regulator, when installed indoors, must be equipped with a vent limiter or a vent line must be installed from the regulator vent to the outdoors.

Specific gas pipe size should be obtained from your supplier or refer to the Gas Pipe Size Chart in this manual.

CAUTION: Gas loop piping must be installed as shown below to maintain equal pressure for all dryers connected to a single gas service. Install other gas appliances upstream from the loop.

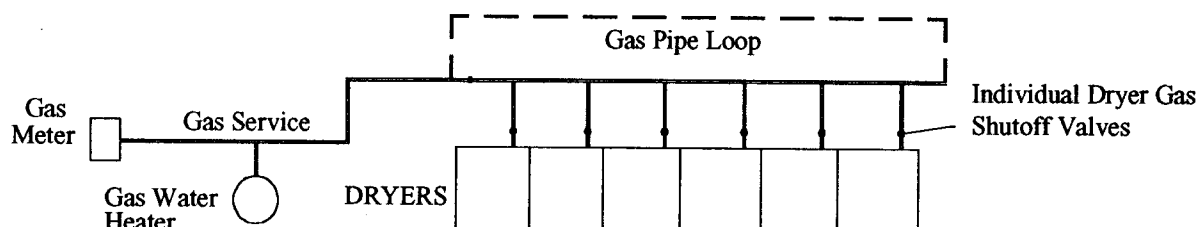

TOTAL BTU/HR
(for L.P. gas
correct total
BTU/HR below
by multiplying
by .6)

GAS PIPE SIZE FOR 1000 BTU NATURAL GAS AT 7" W.C. PRESSURE

In figuring total length of pipe,
make allowance for tees and elbows.

	25 Ft.	50 Ft.	75 Ft.	100 Ft.	125 Ft.	150 Ft.
60,000	3/4	3/4	3/4	3/4	3/4	3/4
80,000	3/4	3/4	3/4	1	1	1
100,000	3/4	3/4	1	1	1	1
120,000	3/4	1	1	1	1	1
140,000	3/4	1	1	1	1	1 1/4
160,000	3/4	1	1	1 1/4	1 1/4	1 1/4
180,000	1	1	1	1 1/4	1 1/4	1 1/4
200,000	1	1	1 1/4	1 1/4	1 1/4	1 1/2
300,000	1	1 1/4	1 1/4	1 1/2	1 1/2	1 1/2
400,000	1 1/4	1 1/4	1 1/2	1 1/2	1 1/2	2
500,000	1 1/4	1 1/2	1 1/2	2	2	2
600,000	1 1/2	1 1/2	2	2	2	2
700,000	1 1/2	2	2	2	2	2 1/2
800,000	1 1/2	2	2	2	2 1/2	2 1/2
900,000	2	2	2	2 1/2	2 1/2	2 1/2
1,000,000	2	2	2	2 1/2	2 1/2	2 1/2
1,100,000	2	2	2 1/2	2 1/2	2 1/2	2 1/2
1,200,000	2	2	2 1/2	2 1/2	2 1/2	2 1/2
1,300,000	2	2 1/2	2 1/2	2 1/2	2 1/2	2 1/2
1,400,000	2	2 1/2	2 1/2	2 1/2	2 1/2	3
1,500,000	2	2 1/2	2 1/2	2 1/2	3	3
1,600,000	2	2 1/2	2 1/2	3	3	3
1,700,000	2	2 1/2	2 1/2	3	3	3
1,800,000	2 1/2	2 1/2	3	3	3	3
1,900,000	2 1/2	2 1/2	3	3	3	3
2,000,000	2 1/2	2 1/2	3	3	3	3 1/2
2,200,000	2 1/2	3	3	3	3 1/2	3 1/2
2,400,000	2 1/2	3	3	3	3 1/2	3 1/2
2,600,000	2 1/2	3	3	3 1/2	3 1/2	3 1/2
2,800,000	2 1/2	3	3	3 1/2	3 1/2	3 1/2
3,000,000	2 1/2	3	3 1/2	3 1/2	3 1/2	4
3,200,000	3	3	3 1/2	3 1/2	3 1/2	4
3,400,000	3	3 1/2	3 1/2	3 1/2	4	4
3,600,000	3	3 1/2	3 1/2	3 1/2	4	4
3,800,000	3	3 1/2	3 1/2	4	4	4
4,000,000	3	3 1/2	3 1/2	4	4	4

GAS PIPING INSTALLATION

1. The installation must conform to local codes or in absence of local codes with the National Fuel Gas Code as ANSI Z223.1-1984.
2. Check with utilities for proper gas pressure and gas supply line.
3. Check for altitude elevation of the dryer.
4. The dryer and its individual shutoff valve must be disconnected from the gas supply piping system at test pressures in excess of 1/2 psig.
5. The dryer must be isolated from the gas supply piping system by closing its individual manual shutoff valve during any pressure testing of the gas supply piping system at test pressures equal to or less than 1/2 psig.

Natural Gas Only - Check the gas pressure inlet supply to the dryer, 12 inches W.C. Pressure maximum. Check the manifold pressure, 3.5 inches W.C. Pressure inside the dryer. **CAUTION:** Low gas pressure and intermittent gas will cause gas ignition problems and inadequate drying of the clothes load.

DRYER INSTALLATION WITH MULTIPLE EXHAUST

For Exhaust Duct more than 14 ft. and 2 elbows equivalent and more than 0.3 in. static pressure.

- ① Make-Up air from outside building may enter enclosure from top or side walls. Area of opening should be equal to 4 - 6 times the sum of dryer duct areas. Provide 1 sq. ft. for each 6 in. diameter; 2 sq. ft. for each 8 in. diameter; and 4 sq. ft. for each 12 in. diameter.
- ② Use constant diameter duct with area equal to the sum of dryer duct areas. Example: 6 - 8 in. diameter duct = 1 - 19.6 in. diameter duct in area. Use 20 in. diameter duct or diameter to match tube-axial fan.
- ③ Enclosure (plenum) with service door. This separates the dryer air from room comfort air. If dryers use room air instead of outside air, the heat loss can be another 25 B.T.U./hr. for each cubic foot per minute (CFM) used. Example: 110 lb. dryer, 2000 CFM = 50,000 B.T.U./hr. loss.
- ④ Zero inches clearance to combustible material allowed on sides and at points within 4 inches of front on top.
- ⑤ Heat loss into laundry room from dryer fronts only is about 60 B.T.U./hr. per sq. ft.
- ⑥ Flange mounted, belt driven tube-axial fan. Fan must run when one or more dryers are running. See suggested automatic electrical control wiring diagram on previous page. Must meet local electrical codes. Fan air flow (CFM) is equal to sum of dryer air flows, but static pressure (S.P.) is dependent on length of pipe and number of elbows.
- ⑦ Barometric By-Pass Damper - adjust to closed flutter position with all dryers and exhaust fan running. Must be located within enclosure.

CAUTION: No two installations are the same. For assistance, consult factory (502) 587-1292. Never install hot water heaters or other gas appliances in the same room as dryers. Never install cooling exhaust fans in the same room as dryers.

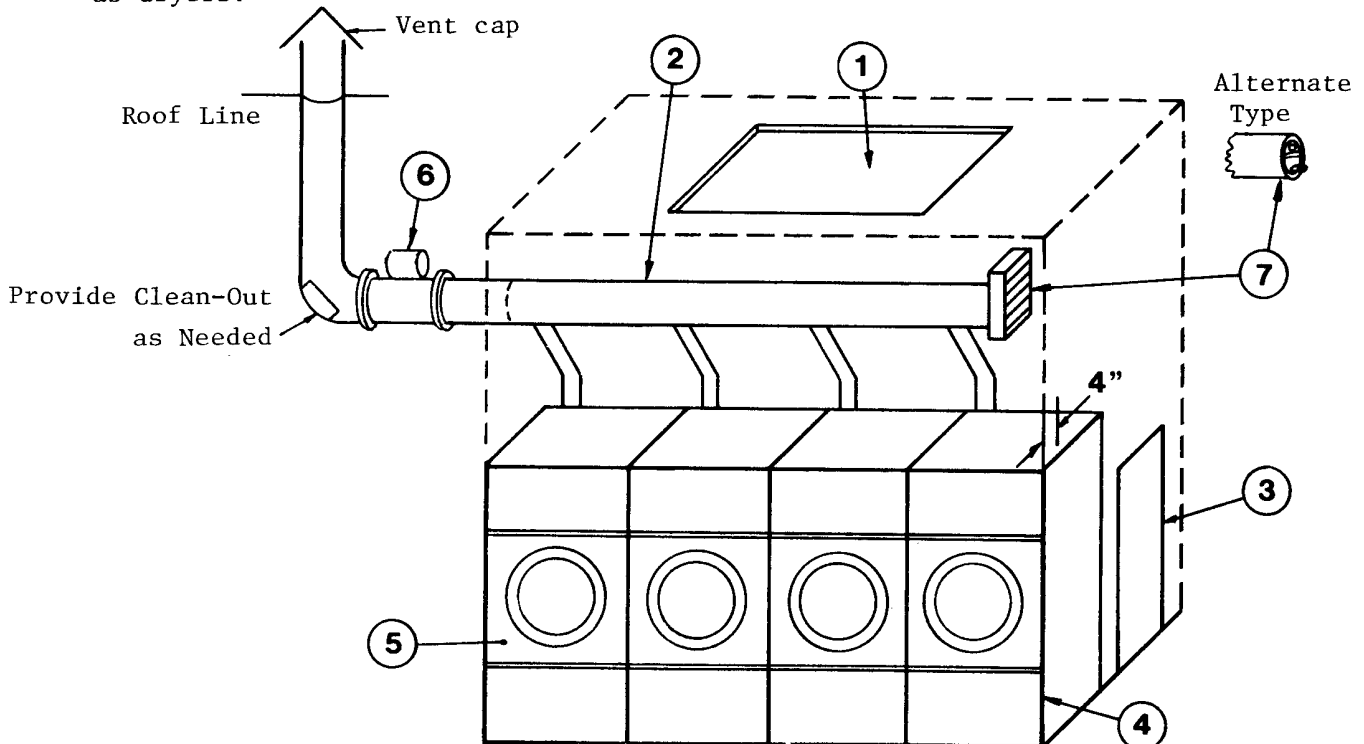

DRYER INSTALLATION WITH SEPARATE EXHAUST (PREFERRED)

For ductwork less than 14 ft. and 2 elbows equivalent and less than 0.3 in. static pressure.

Never exhaust the dryer into a chimney.

Never install wire mesh screen over the exhaust or make-up air area.

Never exhaust into a wall, ceiling, or concealed space.

- 1. Make-Up Air opening from outside the building may enter the enclosure from the top or side walls. The area of the opening should be equal to 4 to 6 times the sum of the dryer duct areas. Provide 1 sq. ft. for each 6 in. diameter; 2 sq. ft. for each 8 in. diameter; and 4 sq. ft. for each 12 in. diameter.

- 2. Enclosure (plenum) with service door. This separates the dryer air from the room comfort air. If dryers use room air instead of outside air, additional heat loss can be another 25 B.T.U./hr. for each cubic foot per minute (CFM) used. Example: a 110 lb. dryer with 2000 CFM = heat loss of 50,000 B.T.U./hr.

- 3. Zero inches clearance to combustible material allowed on sides and at points within 4 inches of front on top.

- 4. Heat loss into laundry room from dryer front panels is about 60 B.T.U./hr. per square foot.

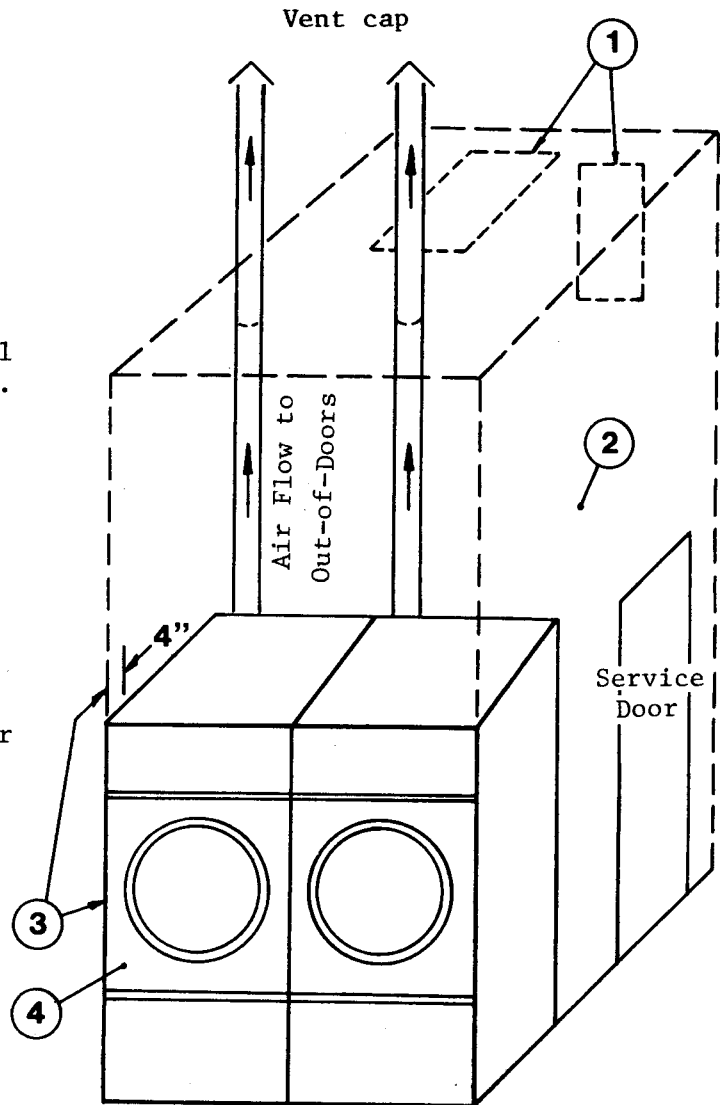

DRYER INSTALLATION WITH MULTIPLE EXHAUST

For Exhaust Duct less than 14 ft. and two elbows equivalent and less than 0.3 in. static pressure.

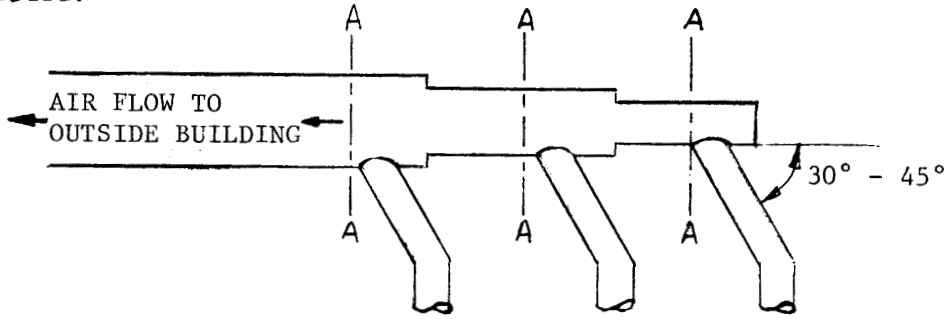

DRYER EXHAUSTS

Area of section "A-A" must be equal to the sum of dryer exhaust pipes entering multiple exhaust pipe. See chart below.

NO. OF DRYERS	1	2	3	4	5	6	7	8	9	10	11	12	13	14	15	16	17	18	19	20	21	22	23	24
DUCT DIAMETER in inches	6	9	11	12	14	15	16	17	18	19	20	21	22	23	23	24	25	26	26	27	28	28	29	30
NO. OF DRYERS	1	2	3	4	5	6	7	8	9	10	11	12	13	14	15	16	17	18	19	20	21	22	23	24
DUCT DIAMETER in inches	8	12	14	16	18	20	22	23	24	26	27	28	29	30	31	32	33	34	35	36	37	38	39	40
NO. OF DRYERS	1	2	3	4	5	6	7	8	9	10	11	12												
DUCT DIAMETER in inches	12	17	21	24	27	30	32	34	36	38	40	42												

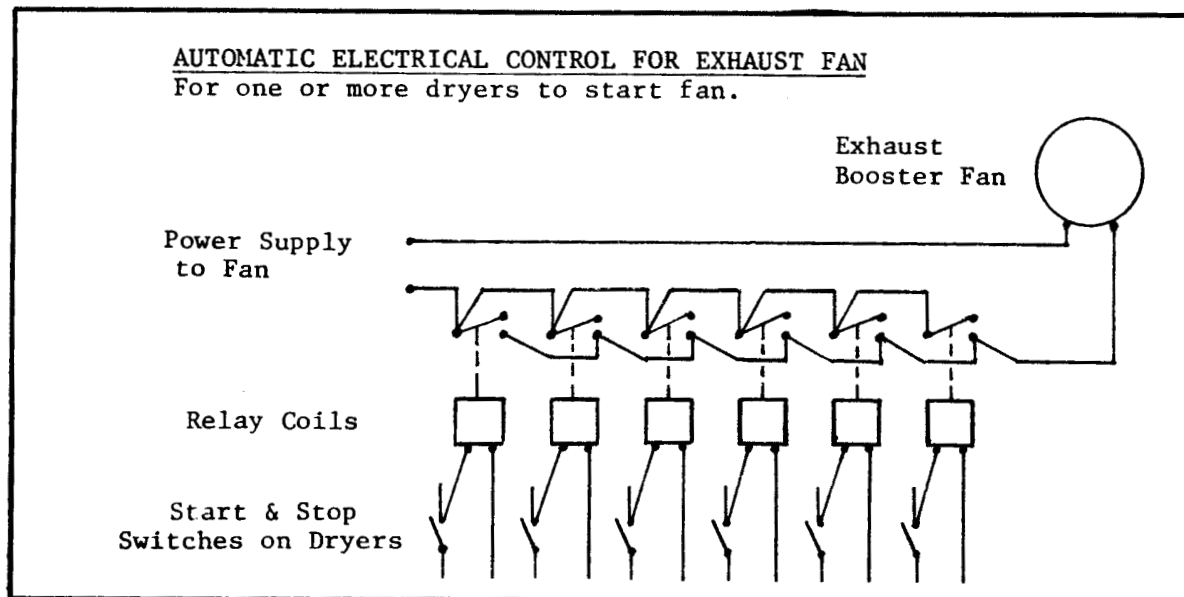

DRYER AIR FLOW INSTALLATION

Nothing is more important than air flow for the proper operation of a clothes dryer. A dryer is a pump which draws make-up air from the out-of-doors, through the heater, through the clothes and then forces the air through the exhaust duct back to the out-of-doors. Just as in a fluid water pump, there must be a fluid air flow to the inlet of the dryer if there is to be the proper fluid air flow out of the exhaust duct. In summary, there must be the proper size out-of-doors inlet air opening (4 to 6 times the combined areas of the air outlet) and an exhaust duct size and length which allows flow through the dryer with no more than 0.3 inches water column static pressure in the exhaust duct.

Energy-saving dryer models require less inlet air area and smaller exhaust ducts than the regular dryers because there is about half as much air flow through the dryer. However, the importance of the proper inlet air area and the correct exhaust duct size is twice as important on energy saving models. The huge savings of an energy-saver dryer is offset only by the attention required to provide the proper air flow. Once this proper air flow is provided, it lasts for the life of the installation.

CISSELL WILL PROVIDE FREE ENGINEERING ADVICE FOR ANY SPECIFIED INSTALLATION.

In some instances, special fans are required to supply make-up air and/or boost exhaust fans are required for both regular and energy saving models.

EXHAUSTING DUCT

For best drying:

1. Exhaust duct maximum length 14 feet of straight duct and maximum of two 90 degree bends.
2. Use 45 deg. and 30 deg. elbows wherever possible.
3. Exhaust each dryer separately.
4. Use 2 feet of straight duct on dryer before installing an elbow, on Energy Saver models only.
5. Do not install wire mesh or other restrictions in the exhaust duct.
6. Use clean-outs in the exhaust duct and clean periodically when needed.
7. Never exceed 0.3 inches water column static pressure in the exhaust duct.
8. Inside surface of the duct must be smooth.
9. Recommend pop rivets for duct assembly.

MAKE-UP AIR

For best drying:

1. Provide opening to the out-of-doors in accordance with the following: For each dryer -
6" dia. exhaust req. 1 sq. ft. make-up air
8" dia. exhaust req. 2 sq. ft. make-up air
12" dia. exhaust req. 4 sq. ft. make-up air
2. Use barometric shutters in the inlet air opening to control air when dryers are not running.

Other Recommendations

To assure compliance, consult local building code requirements.

FOR HELP, consult Cissell Engineering on tough installations.

Trouble Shooting: Hot dryer surfaces, scorched clothes, slow drying, lint accumulations, or air switch malfunction are indicators of exhaust duct and/or make-up air problems.

OPERATING INSTRUCTIONS - TWO TIMER MODELS

- Step 1 After loading the dryer tumbler with the water washed clothes load, proceed to close the loading door. For better drying do not load dryer with combination of garments that twist.
- Step 2 Turn the 60 minute drying timer to the desired drying time. The drying cycle light will be on and indicate the drying. The light shuts off when drying time is complete. See Fig. 1.
- Step 3 Turn the 15 minute cooling cycle timer to the desired cool down time. After The drying cycle is completed, then the cooling cycle time will automatically operate. The cooling light will be on and indicate the cooling of the clothes load. The light shuts off when cooling time is completed. See Fig. 1.
- Step 4 Temperature Selector - Select temperature per type of load being dried in the dryer. See Fig. 2.
High Heat - Mixed and heavy fabrics, set dial to 195°F.
Normal - Cottons and linens, set dial to 170°F.
Permanent Press Heat - Poly knit synthetics-blends-light weight fabrics, set dial to 150°F.
Low Heat - Delicate-sheer fabrics-easy to dry, set dial to 60°F.
- Step 5 Thermometer - Use this with your temperature selection. Teach yourself what temperature is too hot or too cold. See Fig. 3.
- Step 6 Turn switch to "start" position. See Fig. 1.
- Step 7 Close the dryer door, but the basket will not rotate until the PUSH-TO-START BUTTON is pressed. Press in "PUSH TO START" button (approximately 2 seconds) until the dryer starts running and then release button. See Fig. 1.

What is happening to the drying operation:

1. The fan motor will operate.
2. The basket will rotate.
3. The heat source will be energized.
4. The heated air will mix with the water washed clothes to evaporate the moisture from the garments.
5. The thermostats will function to maintain a safe temperature throughout the drying cycle.
6. The heat will be shut off and the motor will continue to run to cool the dry load to a desired handling temperature.

- Step 8 When the drying timer completes its time, then the cooling timer will be energized and the cooling light will be "On". When the cooling timer completes its time the cooling light will go on and the End of Cycle light will be on. The End of Cycle light will go off when the start-stop switch is turned off. At the end of the cool down cycle the clothes load is dry.
- Step 9 To shut the dryer off, move the "start" and "stop" switch to "stop" position. This switch is a safety switch to immediately stop the dryer's operation.

Special Reversing Feature - Set reversing-non-reversing switch to reversing. See service manual for setting of time of each reversal. Reversing of the basket is designed for loads that twist (example - bed sheets and large mixed loads). Non-reverse - small or medium size items (that don't twist).

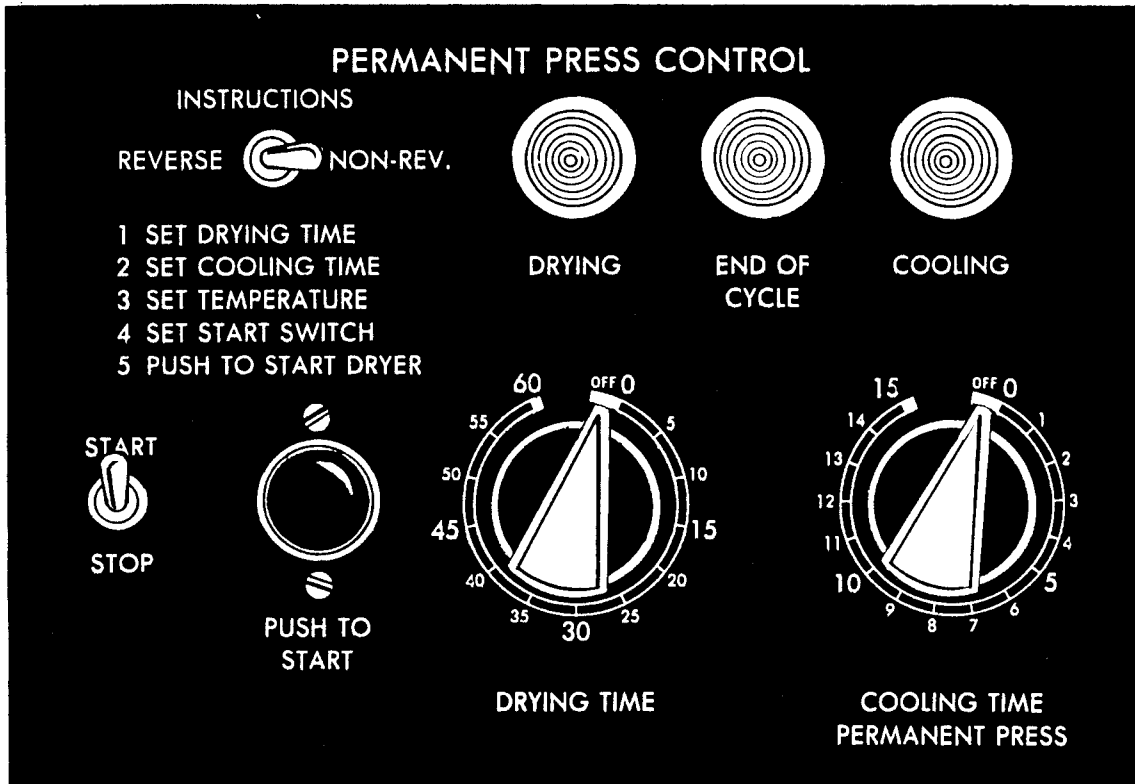

Fig. 1

Fig. 2 Temperature Selection

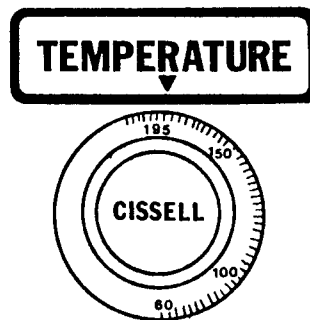
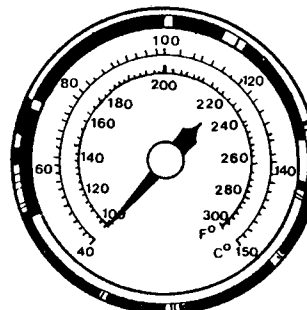

Fig. 3 Thermometer



Burner Air Inlet Shutters Adjustment

TYPE OF GAS	BURNER AIR INLET SHUTTERS ADJUSTMENT
Natural Gas	1/2 Open
Liquid Petroleum	1/4 Open
Manufactured Gas	1/16 Open

Air Shutters Adjustment

Proper Method: Close air shutters to yellow tip, then open air shutters to blue flame tip. Orange tips are impurities in the air such as lint, dust, etc.

Burners air inlet shutters are correctly adjusted when flame is primarily blue.

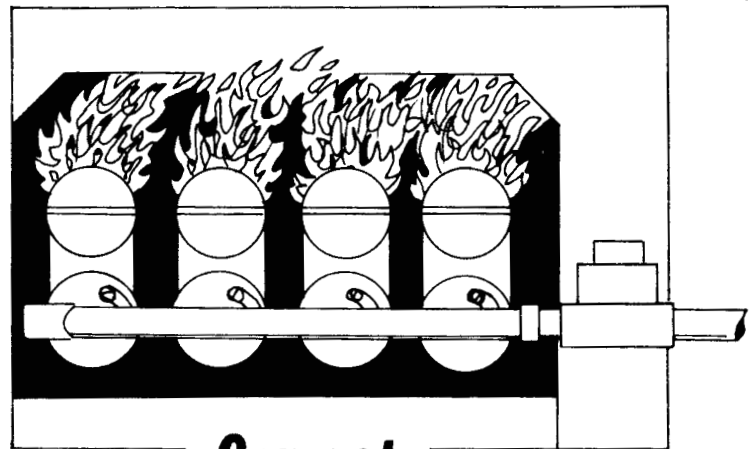

Correct

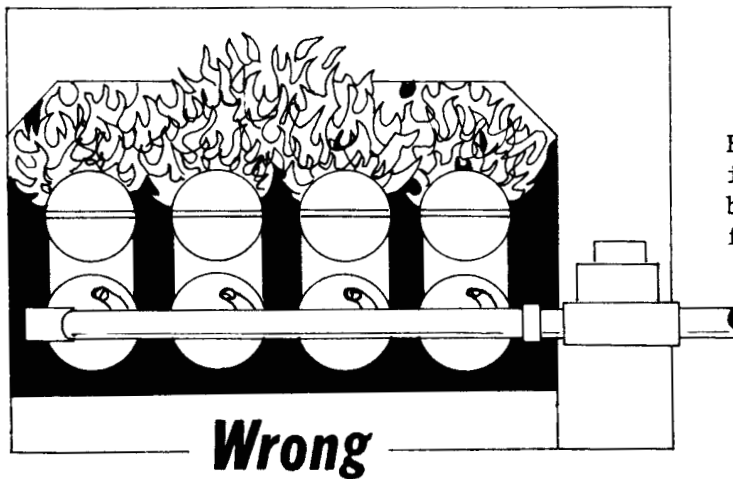

NEED TO ADJUST SHUTTER

Burners Air Inlet Shutters are adjusted insufficient, air is admitted through the burner. Flame pattern is straight up and flame is yellow.

NEED TO PROVIDE CORRECT AIRFLOW THROUGH THE DRYER

This flame pattern indicates the Burner Air Inlet Shutters are correctly adjusted, but air through the dryer is insufficient. This condition indicates excessive lint in the lint compartment, lack of make-up air in the room, restricted exhaust duct, or a vacuum in the room caused by a exhaust fan.

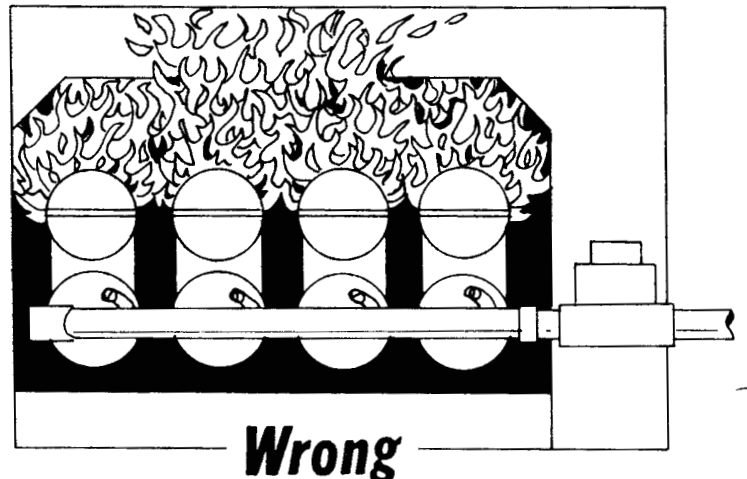

Wrong

AUTOMATIC COMPUTERIZED DRYER CONTROL

DESCRIPTION

The Automatic Computerized Drying Control is used to manage the drying and cooling cycles of one clothes dryer. The operator has the flexibility to select either automatic or timed drying and cooling. When automatic is selected, the drying cycle will be terminated when the clothes are dry. A dryness sensor "feels" the clothes and signals the control when they are dry. In the timed mode, the operator sets the time and temperature for the load.

FEATURES

Automatic/Timed drying selection	Automatic/Timed cooling selection
Fabric selection (automatic mode)	LED display of cycle time
Drying range of 100°F-195°F (timed mode)	Repeat last cycle
Drying range of 0-60 minutes (timed mode)	Safety tumble cycle
Cooling range of 0-60 minutes (timed mode)	Reversing/Non-reversing selection (option)

DRYNESS SENSOR When in the Auto Drying mode, the length of the cycle is controlled by a dryness sensor. The sensor works on a "capacitor charge time" principle. The electronic circuit looks at the charge on the capacitor in the dryness circuit. When the capacitor is fully charged, the circuit ends the drying cycle. One side of the capacitor is connected to a dryness probe located in the center of the basket. Wet clothes hitting the probe will "discharge" the capacitor or prevent it from reaching full charge. As the clothes dry, they have less effect on discharging until finally it is fully charged, ending the drying cycle. The time to charge the capacitor with no clothes load is listed:

<u>Fabric Selection</u>	<u>Charge Time</u>
Heavy	11.5 Minutes
Cotton	5.5 Minutes
Permanent Press	5.5 Minutes
Delicate	5.5 Minutes

LED DISPLAY MESSAGES

<u>Display</u>	<u>Condition</u>
_0	Normal display between loads. Dryer is ready for next load.
012	Normal display of minutes during drying/cooling cycles.
012 (Flashing)	The door is open. Close door and press Start.
-S- (Flashing)	Dryer is in Safety Tumble mode. The cycle has ended, unload the dryer. If the door is not opened in 2 minutes or the Off button is not pressed, the dryer will start a cooling cycle for 30 minutes to prevent clothes from wrinkling.
_PF (Flashing)	Power failure. Press On and Start. To terminate cycle, press Off/Stop. If power failure is less than 24 hours long, settings are in memory, otherwise settings must be re-entered.
FFF (Flashing)	The temperature sensor (thermistor) has failed; must be repaired before continuing.
-A-	Indicates dryer in Automatic mode.

AUTOMATIC COMPUTERIZED DRYING CONTROL

OPERATION OF CONTROL PANEL (See drawing next page)

1. **ON** Turns the control on. If dryer is not used for 30 minutes, the power will turn off. Press On for power.
2. **OFF/STOP** Turns the control off or stops the dryer during a cycle.
3. **START** Starts the cycle or re-starts if off.
4. **COOLING TIME** In Timed mode, with this button held down, the set cooling time in minutes will be displayed. To change the time, use the "up" and "down" buttons while Cooling Time button is down. The cooling time cannot be changed when in Automatic mode. If this button is held down, "-A-" will be displayed.
5. **DRYING TIME** In Timed mode, with this button held down, the set drying time in minutes will be displayed. To change the time, use the "up" and "down" buttons while holding Drying Time down. The drying time cannot be changed when in Automatic mode. If this button is held down, "-A-" will be displayed.
6. **DRYING TEMPERATURE** With this button held down, the drying temperature in degrees F will be displayed. To change the temperature, use the "up" and "down" buttons while Temperature button is down. The temperature cannot be changed when in Automatic mode. If this button is held down, the temperature associated with the fabric selection will be displayed. If both the "up" and "down" buttons are held down at the same time, the actual temperature inside the dryer will be displayed.
7. **FABRIC SELECTOR** Used to select the type of fabric (and temperature) to be dried in Auto Drying mode. Press until desired selection is indicated by light. See chart below for corresponding temperature.

HEAVY	195°F
COTTON	195°F
PERMANENT PRESS	175°F
DELICATE	160°F

8. **DRYING** Pressing this button changes the selection of Automatic or Timed Drying, indicated by a light.
9. **COOLING** Pressing this button changes the selection of Automatic or Timed Cooling, indicated by a light. In Auto Cooling mode, the cycle will end when the temperature falls below 135°F.
10. **REPEAT LAST CYCLE** Pressing this button before the start of a cycle will reset all of the selections to what they were at the beginning of the previous cycle. Press Start to begin the previous cycle.
11. **NON-REVERSING/REVERSING** Pressing this button changes the selection of reversing/non-reversing.
12. **LED DISPLAY** Shows cycle time or temperature. In Auto mode, it shows the minutes used. In Timed mode, it shows the minutes remaining. When the Drying Temperature button is held down, the set drying temperature is displayed. When the Drying Time button is held down, either the total drying time or -A- is displayed, depending on whether Auto or Timed is selected. When the Cooling button is held down, either the total cooling time or -A- is displayed, depending on Auto or Timed selection. See previous page for additional messages displayed.
13. **DRYING** Illuminated when in the drying cycle.
14. **COOLING** Illuminated when in the cooling cycle.
15. **END OF CYCLE** Illuminated at the end of the cycle.
16. **OPEN DOOR** Illuminated if door is opened. The dryer will stop; to re-start, close the door and press Start.

CONTROL PANEL

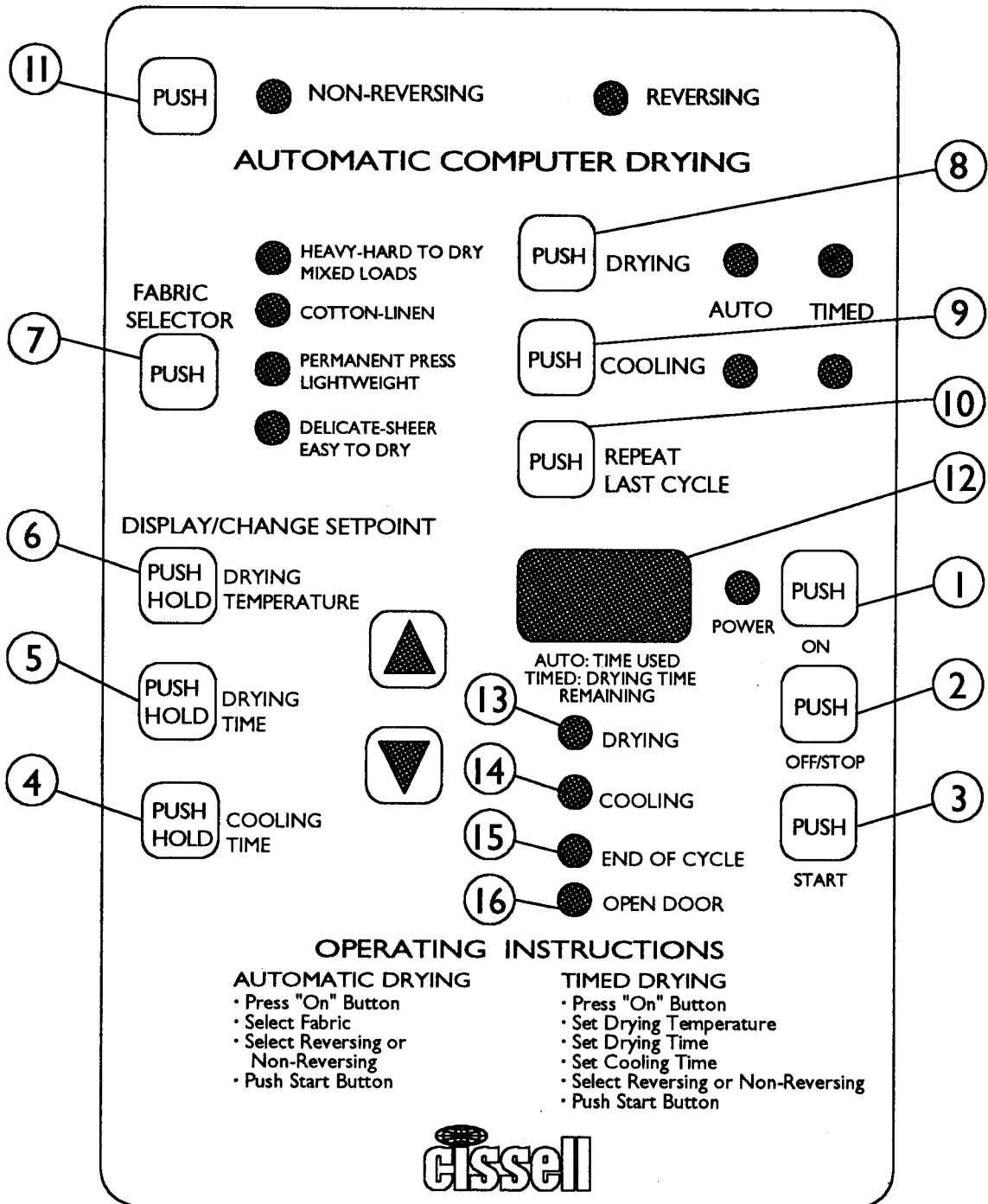

AUTOMATIC COMPUTERIZED DRYER CONTROL

DETAILS OF CONTROL BOARD AND OPTIONS (Refer to drawing on next page)

OPTION SWITCH SET 1	Switch	On	Off
	#8 - F/C	Fahrenheit	Centigrade
	#7 - SFTY/EN	Enabled	Disabled
	#6 - 6-Add	+6 Minutes	0
	#5 - Repeat S/E	Start	End
	#4 - 2 Deg.	+2 Degrees	0
	#3 - 5 Deg.	+5 Degrees	0
	#2 - 10 Deg.	+10 Degrees	0
	#1 - 20 Deg.	+20 Degrees	0

#8 - F/C Select Fahrenheit or Centigrade for temperature LED display.

#7 - SFTY/EN Select Safety Tumble mode to be enabled or disabled.

#6 - 6 Add Used with HEAVY Fabric Selection to add 6 minutes to drying time (Auto mode) for hard-to-dry loads.

#5 - Repeat S/E Used with REPEAT LAST CYCLE. The cycle settings will be stored either at the Start or End of the cycle, based on this switch setting. The stored settings will be used when REPEAT LAST CYCLE is pressed.

#4 - 2 Deg. Adds 2 degrees to the differential temperature.

#3 - 5 Deg. Adds 5 degrees to the differential temperature.

#2 - 10 Deg. Adds 10 degrees to the differential temperature.

#1 - 20 Deg. Adds 20 degrees to the differential temperature.

Note: The differential temperature is part of the heating logic. When the temperature in the dryer reaches the "set" temperature, the heat shuts off. The heat turns on when the temperature falls a certain number of degrees below the "set" temperature. The difference between the "on" and "off" temperature is the differential temperature, which can be set between 5 and 25 degrees. The control "sums" the values set with the switches #4 - #1, but will not go lower than 5 or higher than 25. If the sum is less than 5, it defaults to 5; if the sum is greater than 25, it defaults to 25.

OPTION SWITCH SET 2 - These switches have no function.

THERMISTOR CALIBRATION - To verify the thermistor circuit calibration, proceed as follows:

1. Disconnect the thermistor leads to the circuit board.
2. Short the JP1 terminals (Thermistor Calibration Pins).
3. Hold down the "up" & "down" buttons together to display the temperature. It should read 158°F.
4. If not 158°F, adjust the Thermistor Calibration Potentiometer until it reads 158°F.
5. Remove the jumper at JP1 and connect the leads to the circuit board.

REVERSING DWELL TIME Used to set dwell time on Reversing dryers. The dwell time is the pause when the motor stops and changes direction. Turn the knob counter-clockwise to increase time; clockwise to decrease time.

COMPUTER RESET Push this button to reset, if the computer control "locks up".

120/230V. SWITCH Set to correct input voltage to prevent blown fuses on the control board.

ALARM RELAY This socket is used to add an alarm relay to signal the end of the cycle. Alarm1 and Alarm2 terminals connect to the relay contacts. The relay energizes at the end of the cycle and stays energized until either the door is opened or the dryer control OFF/STOP button is pressed.

CONTROL BOARD

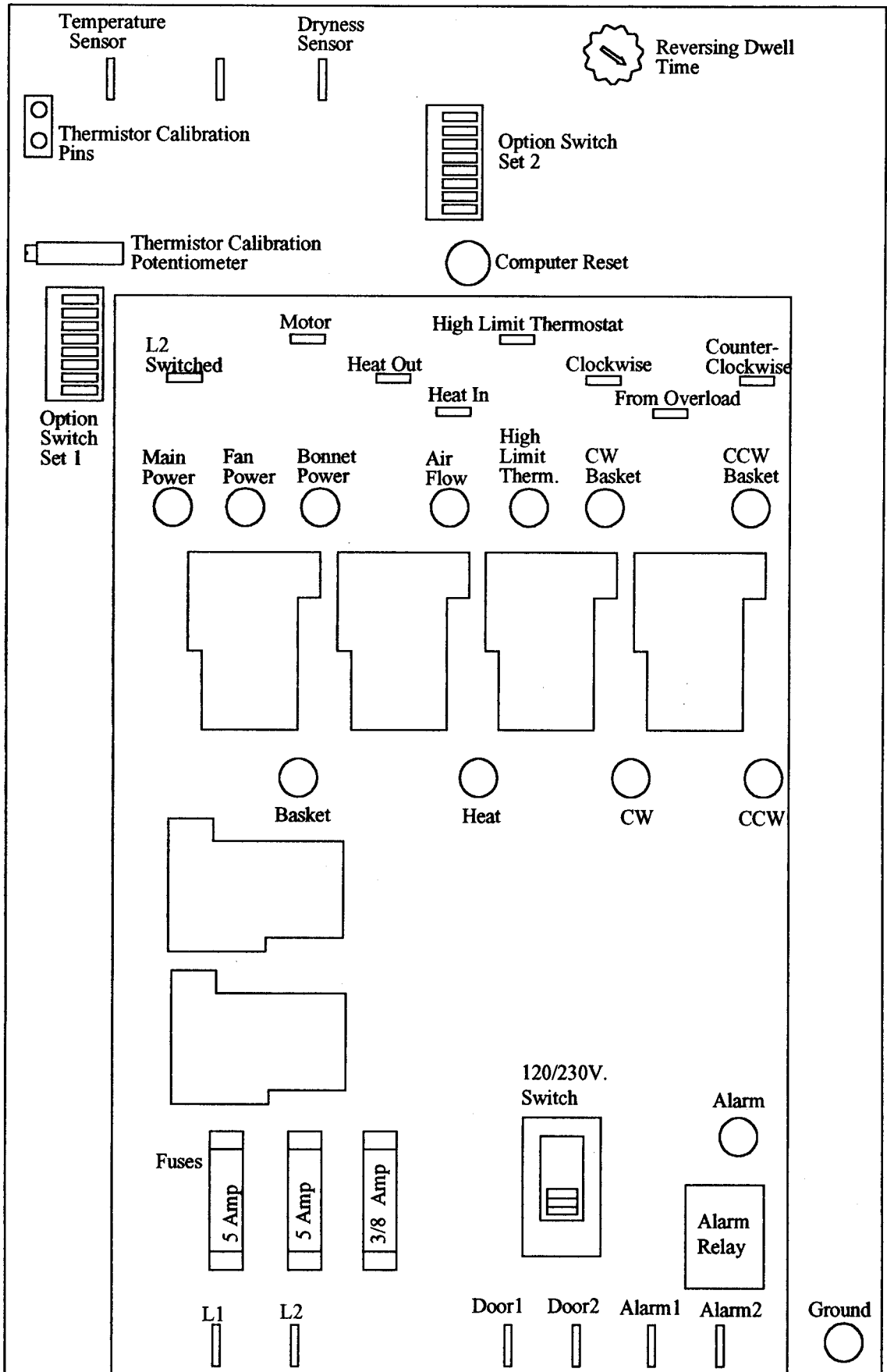

RULES FOR SAFE OPERATION OF YOUR CISSELL DRYER

- (1) Be sure your dryer is installed properly in accordance with the recommended instructions.
- (2) CAUTION: Be safe - Shut main electrical power supply and gas supply off externally before attempting service.
- (3) CAUTION:
 - (A) Never use dry cleaning solvents: gasoline, kerosene, or other flammable liquids in the dryer. Fire & explosion will occur.
 - (B) Never put fabrics treated with these liquids into the dryer.
 - (C) Never use these liquids near the dryer.
 - (D) Always keep the lint screen clean; a full lint screen may be a fire hazard.
 - (E) Never use heat to dry items that contain plastic, foam or sponge rubber, or rags coated with wax or paint. The heat may damage the material or create a fire hazard. Rubber easily oxidizes causing excessive heat and possible fire. Never dry the above items in the dryer.
- (4) Never let children play near or operate the dryer. Serious injury will occur if a child should crawl inside and the dryer is turned on.
- (5) Never use dryer door opening and top as a step stool.
- (6) Read and follow manufacture's instructions on packages of laundry and cleaning aids. Heed any warnings or precautions.
- (7) Never tumble fiberglass materials in the dryer unless the labels say they are machine dryable. Glass fibers break and can remain in the dryer and could cause skin irritation if they become mixed into other fabrics.
- (8) Reference - Lighting and shutdown instructions and wiring diagrams are located on the rear wall of the dryer cabinet.

CAUTION:

Synthetic solvent fumes from drycleaning machines create acids when drawn through the dryer. These acid fumes cause rusting of painted parts, pitting of bright plated parts and completely removes the zinc from galvanized metal parts, such as the tumbler basket.

If the drycleaning machines are in the same area as the tumbler, then the tumbler make-up air must come from a source free of solvent fumes.

ENERGY SAVING TIPS:

1. Install dryer so that you can use short, straight venting. Turns, elbows and long vent tubing tend to increase drying time. Longer dry time means the use of more energy and higher operating costs.
2. Operate dryer using full-size loads. Very large loads use extra energy. Very small loads waste energy.
3. Dry light weight fabrics separately from heavy fabrics. You'll use less energy and get more even drying results by drying fabrics of similar weight together.
4. Clean the lint screen after each load. A clean lint screen helps give faster, more economical drying.
5. Don't open the dryer door while drying you let warm air escape from the dryer into the room.
6. Unload your dryer as soon as it stops. This saves having to re-start your dryer to remove wrinkles.

ELEVATIONS ABOVE 2000 FEET:

Input ratings shown on the rating plate (serial tag) are for elevations up to 2,000 feet. For elevations above 2,000 feet, rating should be reduced at a rate of 4(%) per cent for each 1000 feet above sea level.

SERVICE SAVERS:

To help you trouble shoot the dryer, we list below the most common reasons for service calls ... and some answers to the problems. Before you call for service, please review the following items:

DRYER WON'T START:

1. Is the door completely closed?
2. Are the controls set to a drying position and not to off?
3. Did you push the start control?
4. Has a fuse blown - or a circuit breaker tripped? Are fuses tight?

DRYER WON'T HEAT:

1. Is the dryer set for a heat rather than an air only position?
2. Is the gas valve in the dryer and the valve on the main gas line turned on?

CLOTHES ARE NOT SATISFACTORILY DRY:

1. Timed cycle - Did you allow enough heating time before the cool-down part of the cycle?
2. Is the lint screen blocked?
3. Is the exhaust duct to the outside clean and not blocked? (A blocked exhaust will cause slow drying and other problems)

GAS DRYER IGNITION:

The dryer has a safety device which automatically shuts off the gas if the burner fails to light in a short time. If this happens, turn the dryer off. Check and see if the manual gas valve is open. Wait 5 minutes for the safety device to reset. Then reset the dryer controls. If dryer still fails to heat call for service. All panels, covers and doors must be in place and closed before starting dryer.

VERY IMPORTANT:

When calling the factory for service, always refer to the model number and serial number.

OPERATION OF THE NEW NORTON SILICON CARBIDE IGNITION SYSTEM

Power to the ignition system is 120 volts. It is rated voltage or on higher voltage machines the 120 volts is from a transformer. The ignition system is powered through a timer or coin meter and a thermostat which calls for heat.

The two gas valves are plumbed into a single gas line and both must open before the gas can flow into the burners.

The following diagrams are line to line schematics of the ignition system. The numbers 4, 7, 3, 9, and letters A and B are terminals on the ignition relay.

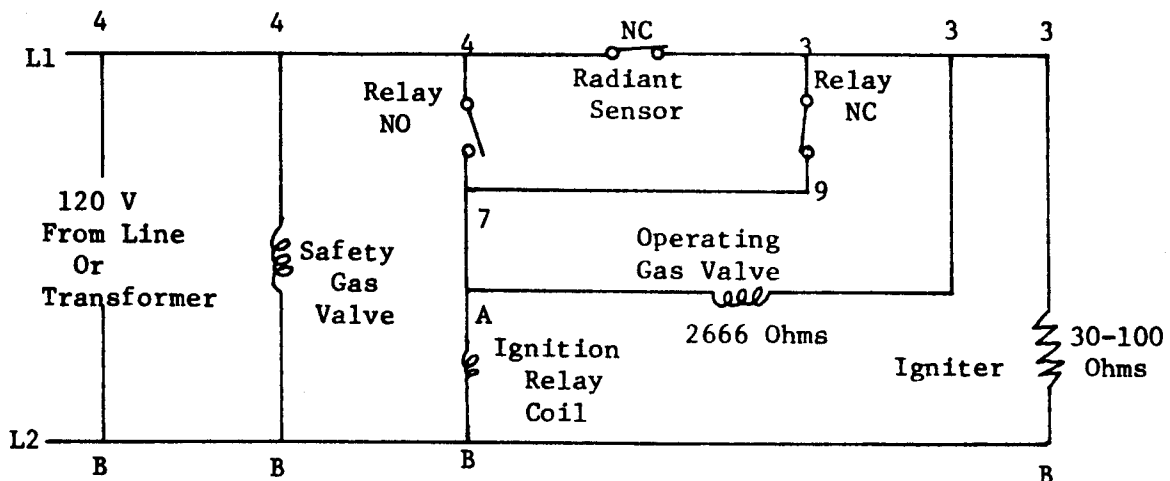

NEW NORTON SILICON CARBIDE IGNITION SYSTEM

Fig. 1 (Start of Cycle)

Step #1 (Start of Cycle), see Fig. 1

- a. The safety gas valve is connected across the lines and opens immediately as soon as a need for heat is indicated by the thermostat.
- b. The ignition relay coil is energized through the normally closed (NC) contacts of the radiant sensor and the NC contacts of the relay. Note! Fig. 1 shows the electrical circuit of the relay just before it is energized. Fig. 2 shows the circuit a moment later.
- c. The igniter is energized through the NC contacts of the radiant sensor.
- d. The operating gas valve is connected such that the same 120 volts is applied to both sides of the gas valve and the valve stays closed.

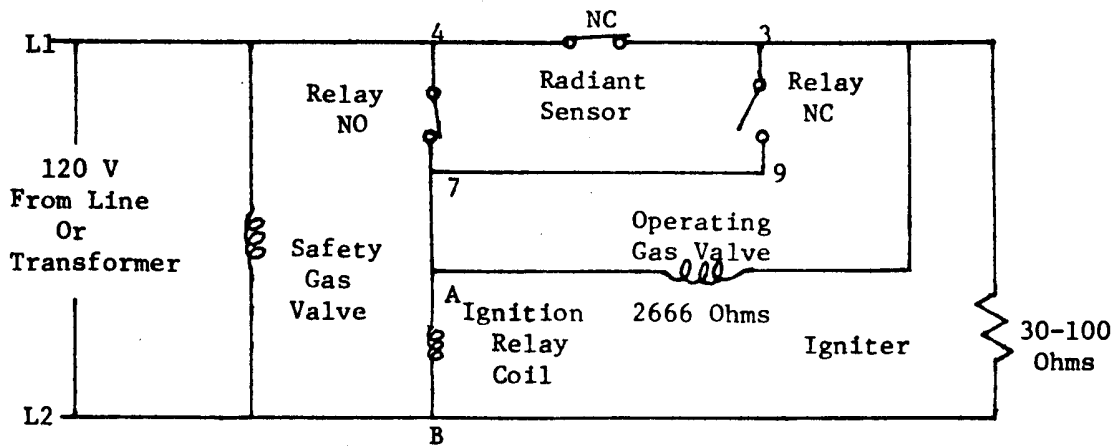

NEW NORTON SILICON CARBIDE IGNITION SYSTEM

Fig. 2 (An Instant Later)

Step #2 (A moment after Step #1), see Fig. 2

- a. The ignition relay closes now and the relay coil stays energized by being powered through the normally open (NO) contacts of the ignition relay which close before the NC contacts open.
- b. The operating gas valve still has the 120 volts applied to both sides of the gas valve and the valve stays closed.

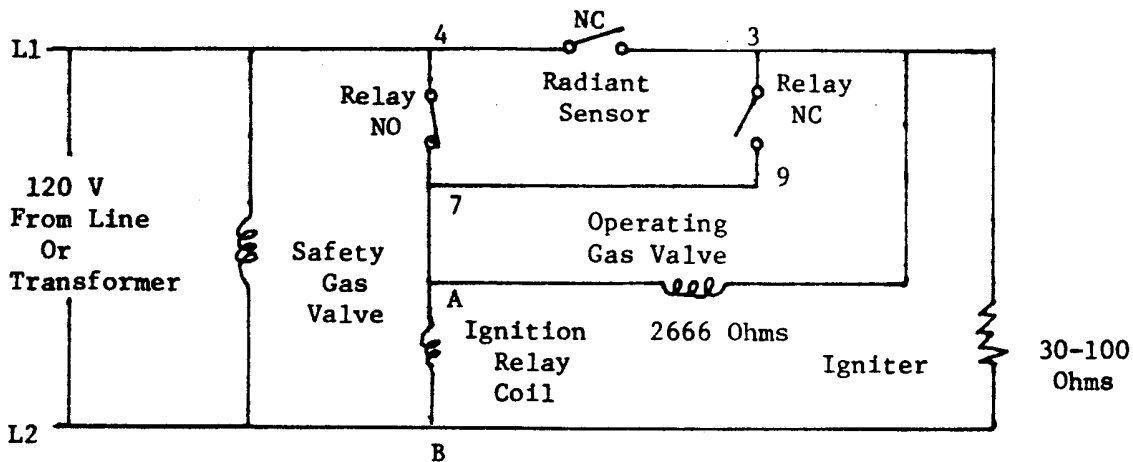

NEW NORTON SILICON CARBIDE IGNITION SYSTEM

Fig. 3 (About 20 Seconds Later)

Step #3 (About 20 seconds after Step #2), see Fig. 3

- a. The igniter glows red hot which causes the radiant sensor to open its NC contacts which de-energizes the igniter.
- b. As the radiant sensor NC contacts open, the 120 volt to one side of the operating gas valve coil is removed and an electrical circuit is formed through the NO contacts of the ignition relay,

through the gas valve and through the igniter, and the gas valve opens. The relatively low resistance of the igniter allows nearby full voltage to be applied to the operating gas valve and nearby zero voltage to the igniter and the igniter is de-energized for all practical purposes.

- c. As the raw gas flows against the red hot igniter, ignition takes place. The radiant gas flame replaces the radiant glowing of the igniter and the radiant sensor NC contacts remain open.

The flame will burn until the thermostat opens the circuit or until the time on the timer or coin meter expires.

The following summarizes the ignition operation.

Start machine drying cycle. Carbide igniter will get red hot. Then gas valve will open. The gas burners are ignited by the carbide igniter. Igniter will shut off and burners will remain on during drying cycle.

Opening tumbler door will cause gas to extinguish. Shut door and gas will not light until flame sensor cools and normal ignition cycle begins.

Note! Push start switch after door is shut.

If gas does not light, then the sensor will cool down and restart the ignition cycle.

Safety Features

Power Interruptions During Burning of the Gas

Both gas valves are de-energized and the gas is shut off. The ignition relay is also de-energized and returns the contacts to the NO and NC positions. Even with resumption of power, the operating gas valve stays closed until the NC contacts of the radiant sensor close (about 30 seconds from time of power interruption). A normal ignition cycle begins at this time.

Burner Doesn't Light Because of Low Voltage or Low Gas Pressure

The operating gas valve will be energized for about 30 seconds and then the NC contacts of the radiant sensor will be closed. 120 volts is applied to both sides of the operating gas valve and it closes to shut off the gas. A normal ignition cycle begins at this time.

NORTON IGNITION SYSTEM

CAUTION: Front and rear Glo-bar ignition systems are energized by one timer system, one set of thermostats, one air switch, one door switch, one relay and one selector switch.

Test Procedure

- 1) Two Glo-bars will glow red.
If Glo-bars do not glow red, then check the following:
 - (a) Disconnect Glo-bar wiring from dryer - test with separate 120V. Replace if it does not glow red.
 - (b) Also replace Glo-bar if cracked, broken or does not light burner in 25 seconds.
- 2) Unit must be wired correctly. Refer to wiring diagram on front & rear of dryer.
- 3) Rear and front gas valves must open (click) when dryer is energized.
- 4) Rear and front gas valves will open and gas will flow to burners after 12 to 25 seconds, when Glo-bars is glowing red. Red Glo-bars will light gas from burners.
- 5) Glo-bars will go out when flame is burning.
 - (a) If four gas valves do not open (click), then replace.
 - (b) If units do not operate correctly, then replace the relay.
 - (c) If Glo-bars do not shut-off, then replace radiant sensors. Also if the radiant glass is broken, replace.

NORTON IGNITION SYSTEM

- 6) Parts in unit:

Two Norton Glo-bars
Two Ignition Radiant Sensors
Two Ignition Relays
Four Gas Valves
- 7) Open and close loading door after gas is burning and Glo-bars are shut-off. Gas should not flow when door is reclosed until radiant sensor has cooled and Glo-bars recycles.

TROUBLE SHOOTING ON EACH NORTON IGNITION PART

- A) Glo-bars
 - 1) No Glo-bars red - Check voltage (120V)
 - Cracked or broken, replace
 - Check wiring. Must be connected to No. "B" and No. "3" on relay.

B) Radiant Sensor
Front & Rear Ignition Systems:

- 1) No Glo-bar red - Contacts failed open position, replace.
 - Sensor N.C. (cold position)
 - Sensor open (hot position)
 - Glass broken, replace.
- 2) Fails to open after 25 seconds
 - Low voltage on glo-bar
 - Not in correct location
 - Glass broken, replace
 - Failure of contacts to open, replace.

C) Relays (Igniter)

- 1) Front or rear gas valves do not turn on.
 - Relay is wired incorrectly
 - Relay solenoid not operating
 - Relay contacts not operating correctly
- 2) Relay contacts should make before break - when the relay coil is energized, the contacts "4 & 7" should close before contacts "3 & 9" open.

D) Gas Valves

- 1) If valve does not open when 120V is applied to it, then replace the coil assembly.
- 2) The four gas valves must be wired correctly. Refer to rear and front wiring diagrams.

INSTRUCTIONS FOR THE DIRECT
IGNITION SYSTEM OPERATION

1. Turn on manual gas valve; handle should be parallel with gas line.
2. Start machine's drying cycle. Two carbide igniters will get red hot; then four gas valves will open. The gas burners are ignited by the carbide igniters. Igniters will shut off and burners remain on during heat cycle.
3. Opening tumbler door will cause all gas to extinguish. Shut door and gas will not flow until flame sensors cool and normal cycle begins.
NOTE! Push start button after door is closed.
4. If gas does not light on rear and front systems, the sensors will cool down and restart both ignition cycles.
5. To shut off dryer, turn off manual gas valve. Handle should be at right angle to pipe. Turn off main electrical supply switch.
6. If gas burners fail to ignite, please wait 5 minutes for a complete shut-off period before next attempt.

MAINTENANCE

1. **CLEAN LINT TRAP DAILY.** Remove lint before starting day's operation. A clean lint trap will increase the efficiency of the dryer, as the moisture laden air will be exhausted more quickly.
2. **CLEAN BASKET AND SWEEP SHEETS.** Clean periodically and/or as often as required. The basket and sweep sheets are easily accessible by removing the front panel of the dryer.
3. **GEAR REDUCER.** Maintain the oil level at 1/2 the depth of the oil cup using Cissell transmission oil. See separate page on Gear Reducer Operation and Maintenance for detailed information.
4. **PULLEYS AND BELTS.** Keep belts clean. Oil and dirt will shorten the useful life of the belt. Never allow a belt to run against the belt guard. Check periodically for alignment. Pulley shafts must be parallel and the grooves must be aligned. Check and re-tighten pulley set screws periodically. Check belt tension periodically. Lower motor to increase tension by adjusting the nuts fastening the motor plate to the rod connected to the Gear Reducer.
5. **ELECTRIC MOTORS.** Keep motors clean and dry. Motors having ball bearings are packed with sufficient grease for approximately five years of normal operation. After five years, the bearings and housing should be cleaned thoroughly. Repack each bearing and the cavity in back of the bearing one-third full with Chevron Grease No. SR1-2.

Motors having wool packed sleeve bearings are oiled at the factory for one year of normal operation. After one year, add annually one-half teaspoon of electric motor oil or S.A.E. #10 to each bearing. For 24 hour per day operation, add one teaspoon of oil annually.

If motors overheat, check voltage and wiring. Low voltage, inadequate wiring, and loose connections are the main cause of motor failure.

6. **STEAM HEATED UNITS.** Keep steam coils clean. Check periodically and clean often as required. Remove lint and dirt build-up from fins. Dirty fins decrease the efficiency of steam heated units.
7. **GAS BURNERS.** Keep burners clean. Check and clean often.
8. **GAS PRESSURE** should be checked periodically per specifications on separate page.
9. **EXHAUST SYSTEM.** Periodically check and clean.
10. **VOLTAGE** should be checked periodically per rating plate located on rear wall of dryer.
11. **COMBUSTION (MAKE-UP) AND VENTILATING AIR** flow should not be obstructed.
12. Keep dryer area clean of lint and free from combustible materials, gasoline, and other flammable liquids/vapors.

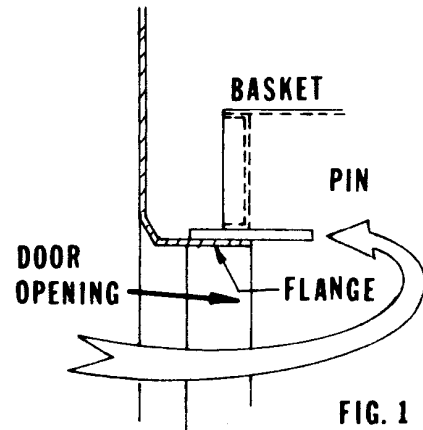
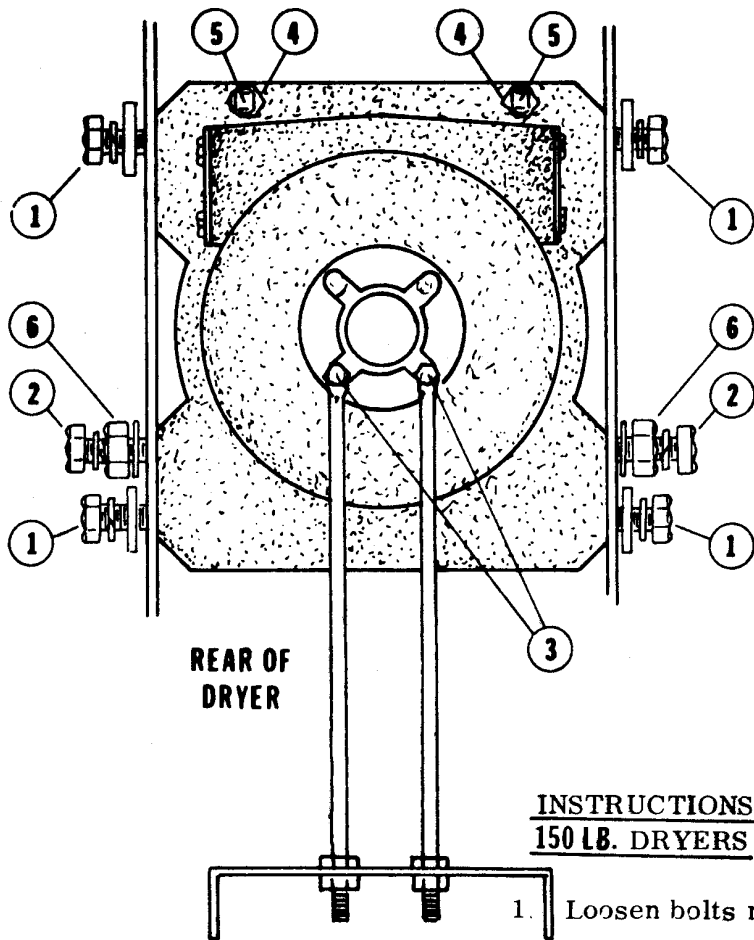

**INSTRUCTIONS FOR ALIGNING BASKETS ON CISELL
150 LB. DRYERS**

1. Loosen bolts numbers one (1) thru five (5).
2. Place pin "A" in position shown in Fig. 1 & 2.
3. Check pins "B" at position shown in Fig. 1 & 2 for equal clearance.
4. If pin "B" clearance is unequal, adjust at nut #6.
5. When clearance at pin "B" is correct, tighten bolts #1 in following order, as viewed from rear of dryer, top right, bottom left, top left and bottom right.
6. Tighten bolts #5 until flush against back of dryer. Tighten lock nut #4 to secure bolt #5 in position.
7. Tighten bolts #2 and #3.
8. Remove pin "A" and check for proper clearance at points and "B". If clearance is incorrect, repeat the above steps.

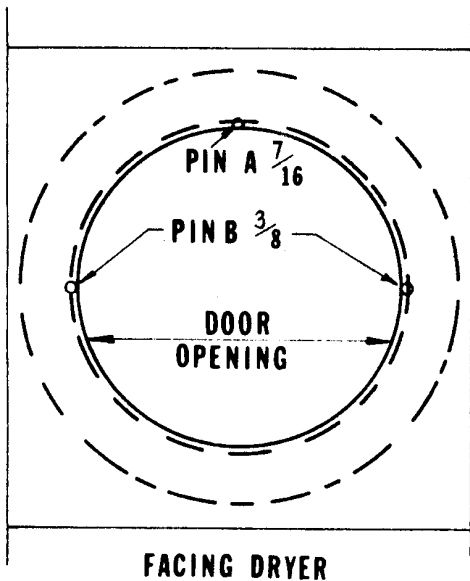

FIG. 2

NOTE: USE SHORT SECTIONS OF ROUND STEEL ROD FOR PINS OR DRILL BITS MAY BE USED IN PLACE OF ROUND ROD.

INSTRUCTIONS FOR SHIMMING THE BASKET & SPIDER ASSEMBLY

This procedure is usually necessary when replacing the basket or spider assembly on any Cissell dryer. The alignment of these two parts is crucial in assuring a true running basket.

- A. Align the basket per instructions on previous page.
- B. Rotate the basket to determine where the most out of round point is (where the basket scrapes or comes close to scraping the sweep sheet.).
- C. Mark this position and the nearest rib to this position. If it is between two ribs, both ribs may need to be shimmed.
- D. Remove the basket from the dryer (do not loosen the alignment bolts).
- E. With the basket on the floor (spider up), loosen the cap screws and tie rod nuts enough to insert one or two shims between the spider leg and the basket at the marked position. With shims in place, tighten the screws and nuts.
- F. Install spider and basket assembly and check again.
- G. If basket is still out of round, start at Step B and repeat procedure.
- H. When shimming is completed, re-align basket.

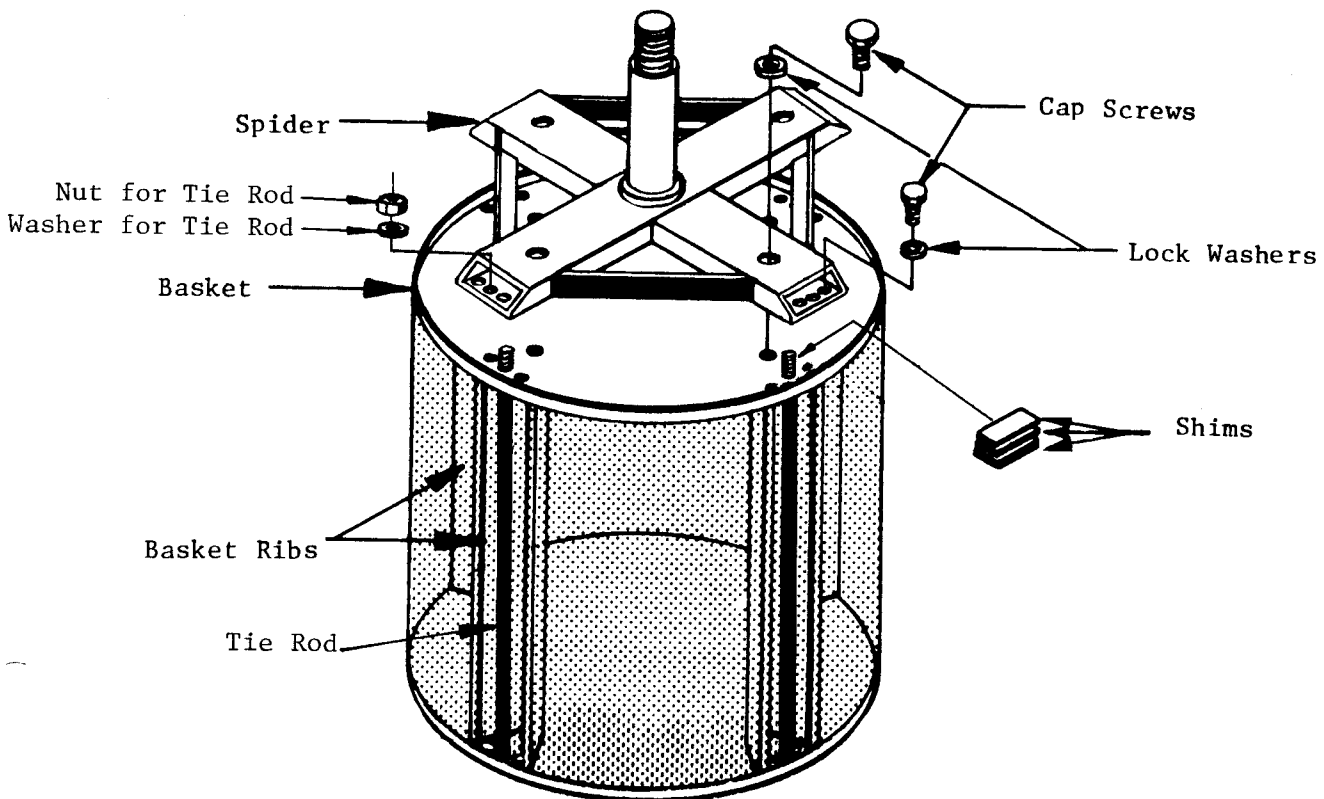

Large Gear Reducer 50-42

Operation and Maintenance

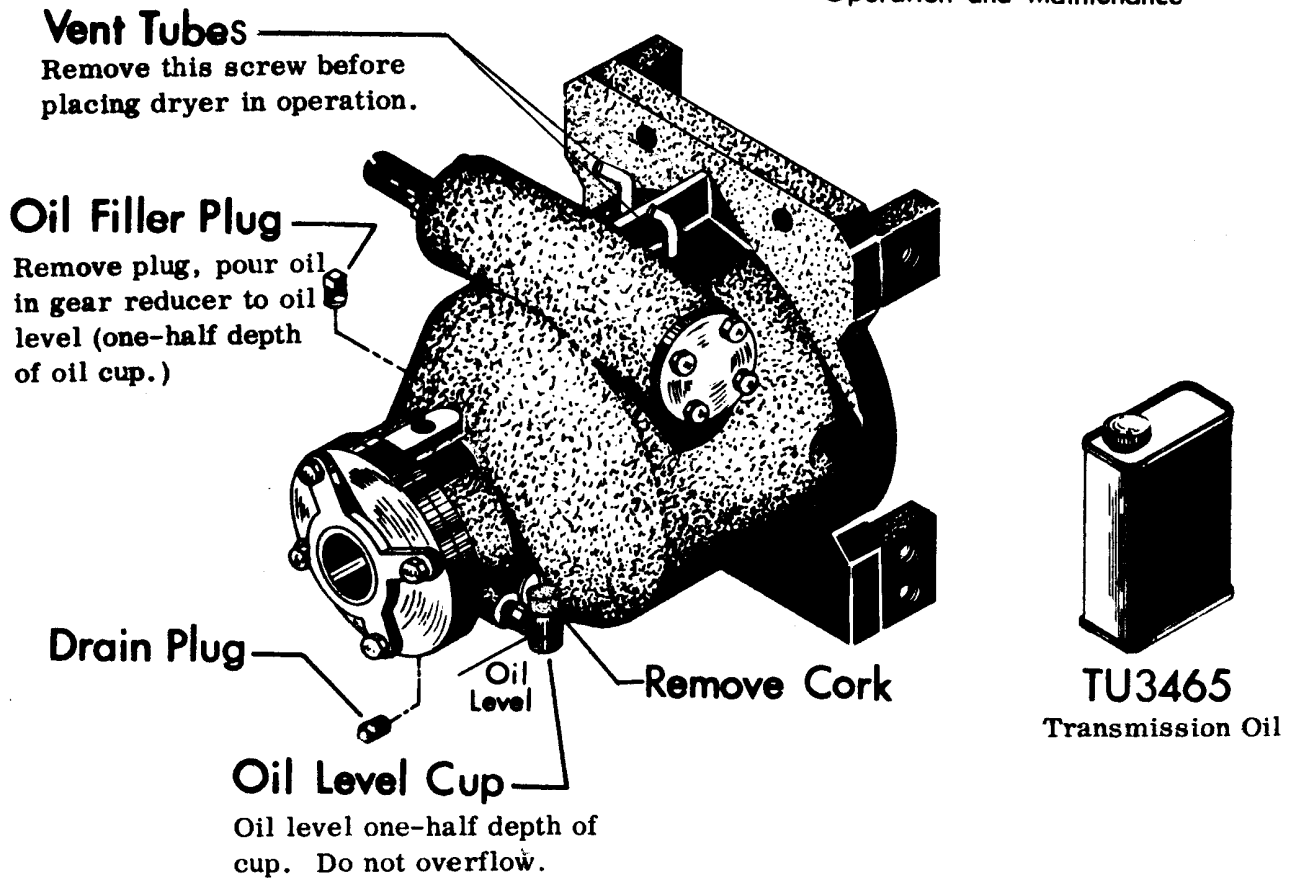

BEFORE PLACING THE DRYER IN OPERATION, Remove small screws from vent tubes in top rear of each Gear Reducer case. Remove the cork from the oil level inspection cup. If the oil level is correct, the oil level inspection cup will be half filled with oil. If not, add oil. Oil may be added to the Gear Reducer by removing the filler plug in the top rear of the Gear Reducer case. Do not operate a Gear Reducer unless the drain plug is tight, and the vent tube screw removed.

If it is necessary to return a Gear Reducer to the factory, either replace the small screws in the vent tubes and plug the oil-level inspection cup with a cork, or drain all oil from the reducer by removing the drain plug located in the bottom rear of the Gear Reducer case.

EACH GEAR REDUCER is filled with 5 pints of Cissell TU 3465 transmission oil before leaving the factory. Change oil once every 6 months.

THE LARGE TIMKEN BEARINGS, which support the worm gear and basket load, must operate in a preloaded condition, that is the worm gear must not have end play. The Gear Reducer is assembled at the factory to provide a 16-20 inch lb. pre-load on these bearings.

THE SMALL TIMKEN BEARINGS, which carry the worm must operate in a pre-loaded condition, that is, the worm must not have end play. The Gear Reducer is assembled at the factory to provide a 2-4 inch lb. preload on these bearings.

AIR SWITCH ADJUSTMENT

1. Shut off current; disconnect leads and remove air switch.
2. Lay air switch assembly on flat surface. Adjust air blade at "A" (fig. 1) so that air blade lays flat and surface "B" is parallel to the flat surface.
3. Place 3/8" x 5/8" spacer bar or equivalent "C" (fig. 2) under air blade in position shown; hold switch mounting bracket firmly and adjust switch actuator "D" with needle nose pliers at "E" by twisting actuator right or left whichever is needed so that switch closes when end of air blade engages bar "C".
4. Maximum opening of air switch must be no greater than 3/4" (fig.3). Bend tab "F" in or out to maintain this dimension.
5. Re-install air switch assembly on rear of dryer.
6. Re-check operation of air blade. Switch must close before air blade engages face of opening and re-open before stop "F" engages.

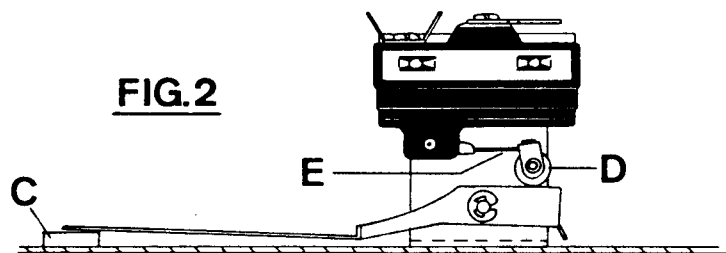
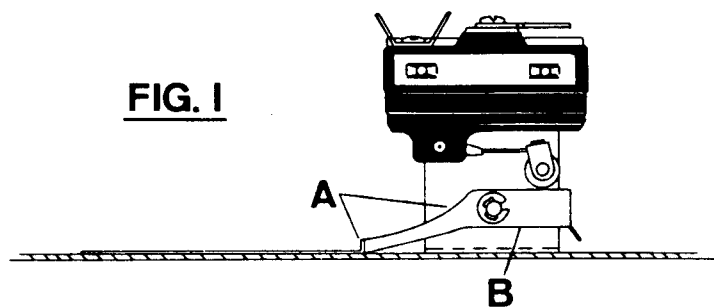
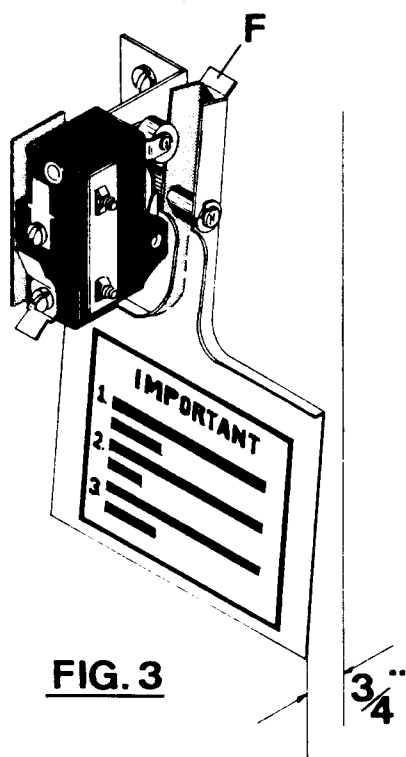

INSTALLATION INSTRUCTIONS FOR THE NORTON IGNITER

1. Disconnect igniter wires at the connector .
2. Remove the ignition burner from the gas bonnet.
3. Remove the old igniter from the burner and save the heat shield and hardware.
4. Assemble the heat shield and new igniter. (Figure 1)
5. Place the igniter and heat shield under the bracket on the ignition burner. Fasten in place and tighten securely. (Figure 2)
6. Install the burner into the original position and connect the wires to the connector.

Figure 1

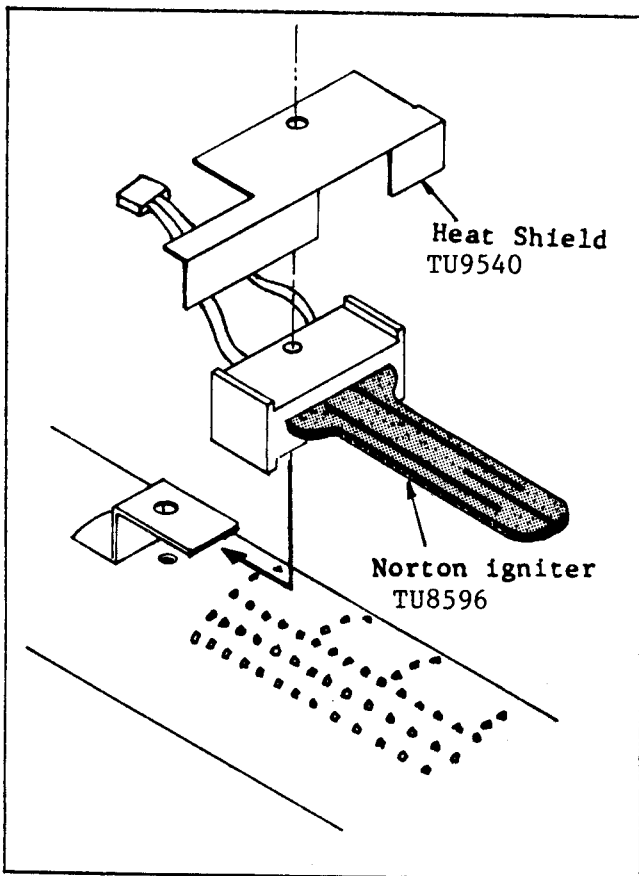
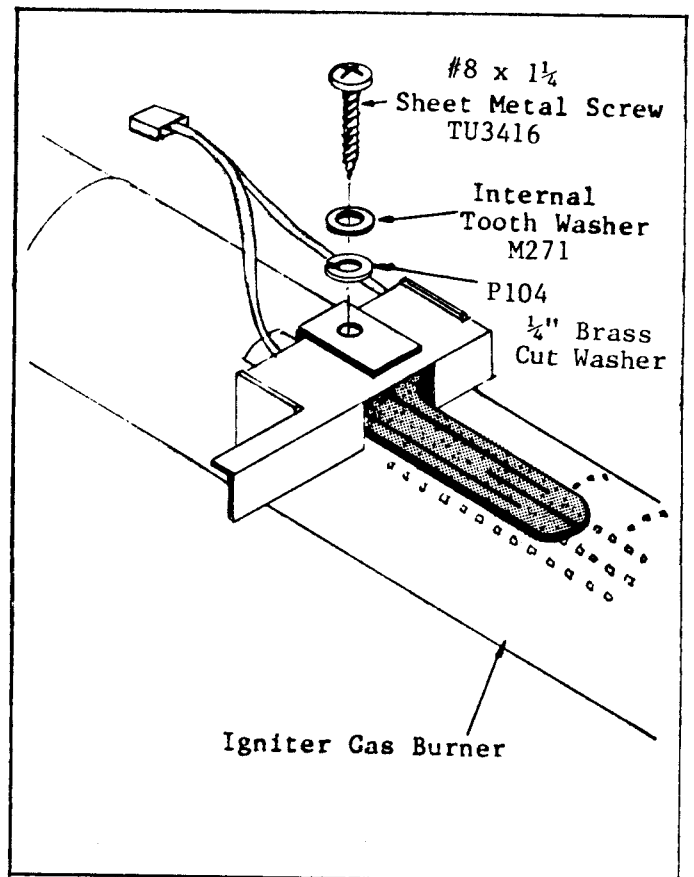

Figure 2



INSTRUCTIONS FOR DRYERS WITH REVERSING CONTROL TIMER

In operation, coasting of basket increases, making it necessary to readjust reversing timer:

CAUTION:

Failure to do this will cause the thermal overload units for the basket to cut-out unnecessarily and probably damage gear reducer.

Adjustment of Reversing Timer:

CAUTION: Dryer power supply must be shut off before adjusting timer.

1. Reversing timer operates 18.7 seconds per reversal.
2. Rotate upper cam clockwise to increase stop time between reversals, counter-clockwise to decrease.
3. Lower cam has 10 divisions. Normal adjustment, 3 divisions, as shown.
4. Each division adds 1.87 seconds. Example:
3 divisions "off time" - 5.61 seconds
7 divisions "on time" - 13.09 seconds.
5. Recommended time basket must stop completely for 5 to 7 seconds between reversals. Minimum basket stopping time is 4 seconds.

CAUTION

ONLY Operate Non-Reversing and Reversing SWITCH when basket is rotating or basket will not rotate.

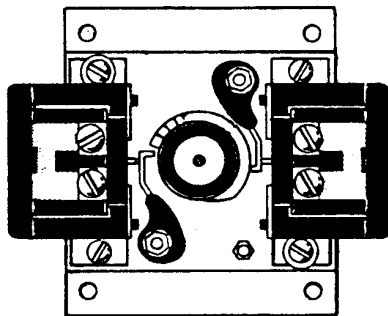

Furnas Timer

FAN ROTATION

NOTE: Fan rotates counter-clockwise as viewed from back end of motor. See arrow on motor support. To change rotation, reverse power leads L1 & L2.

INSTRUCTION FOR DRYERS WITHOUT REVERSING CONTROL
FAN AND BASKET ROTATION

NOTE: Fan rotates counter-clockwise as viewed from back end of motor. See arrow on motor support.

Basket rotates counter-clockwise as viewed from back end of motor. See arrow on motor support.

Basket rotates counter-clockwise as viewed from front of tumbler.

To change rotation of both fan & basket, reverse power leads L1 and L2.

To change rotation of fan only, reverse motor leads F1 and F2.

To change rotation of basket only, reverse motor leads B1 and B2.

50,75,110 & 150LB DRYERS REVERSING TIMER AND TRANSFORMER

- ① TU12874 TIMER , SOLID STATE REVERSING 24 VOLT 50/60HZ
- ② TU12989 TRANSFORMER 120V PRI/24V SEC 50/60HZ 10VA
TU12990 TRANSFORMER 240V PRI/24V SEC 50/60HZ 10VA

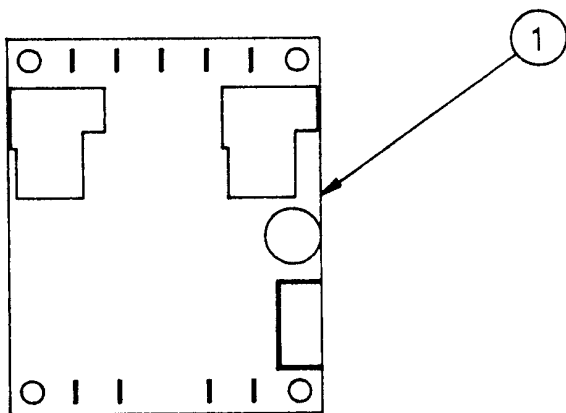
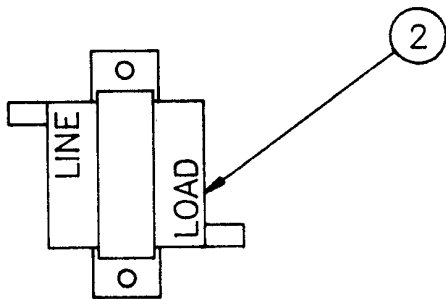

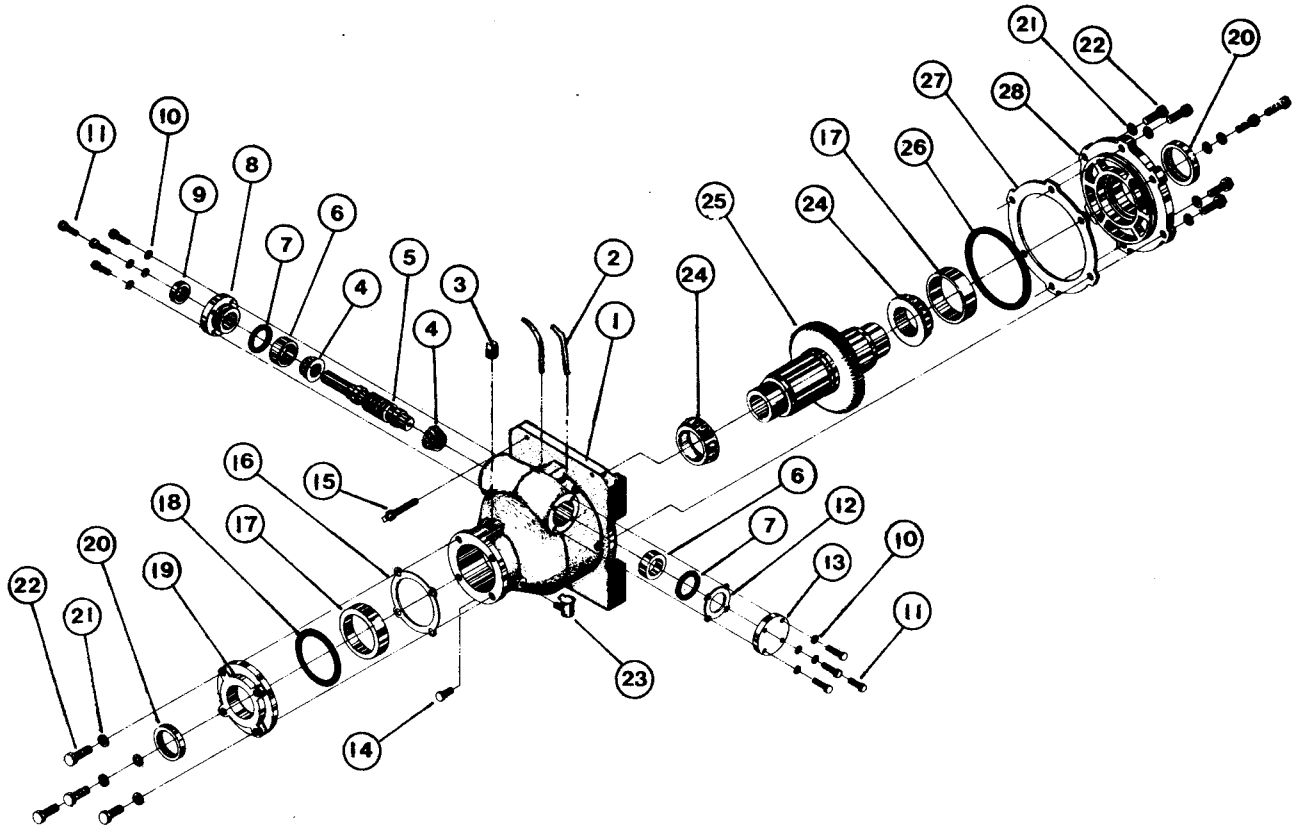

TU12977 - LARGE GEAR REDUCER W/BRONZE TEETH

<u>REF. NO.</u>	<u>PART NO.</u>	<u>DESCRIPTION</u>	<u>REF. NO.</u>	<u>PART NO.</u>	<u>DESCRIPTION</u>
1	TU404	Housing	17	TU2537	Large Bearing Cup
2	TU69	Vent Tube	18	TU89	Large "O" Ring
3	J36	½" Pipe Plug	19	TU458	Large End Cap 6½" Dia.
4	TU2535	Small Bearing Cone	20	TU2536	Large Klosure
5	TU441	Worm	21	TU3243	3/8" Internal Tooth Lock Washer
6	TU2534	Small Bearing Cup	22	OP380	3/8"-16x1½" Cap Screw
7	TU487	Small "O" Ring	23	TU70	Oil Cup
8	TU406	Small Open End Cup	24	TU2538	Large Bearing Cone
9	TU2533	Small Klosure	25	TU12877	Worm Gear
10	VSB134	3/8" Split Lock Washer	26	TU448	Extra Large "O" Ring
11	TU3246	3/8"-16x1" Cap Screw	27	TU1905	Shim 9¼" - Set of 3 If Needed
12	TU447	Small Shim, Set of 3 If Needed	28	TU405	Large End Cap 10 3/8" Diameter
13	TU407	Small Closed End Cap			
14	X170	¼" Pipe Plug			
15	TU5312	3/8"x3" Set Screw			
16	TU1828	Large Shim (Set of 4)			

(TU3465 - One pint of Cissell transmission oil - not illustrated)

REVERSING CONTROL PANEL ASSEMBLY

TU9812 Reversing Control Panel - 208/240/60/3 w/240V. Controls
 TU9814 Reversing Control Panel - 240/415/50/3 w/240V. Controls
 TU10122 Reversing Control Panel - 208/60/3
 TU10123 Reversing Control Panel - 240/415/50/3
 TU10125 Reversing Control Panel - 480/60/3

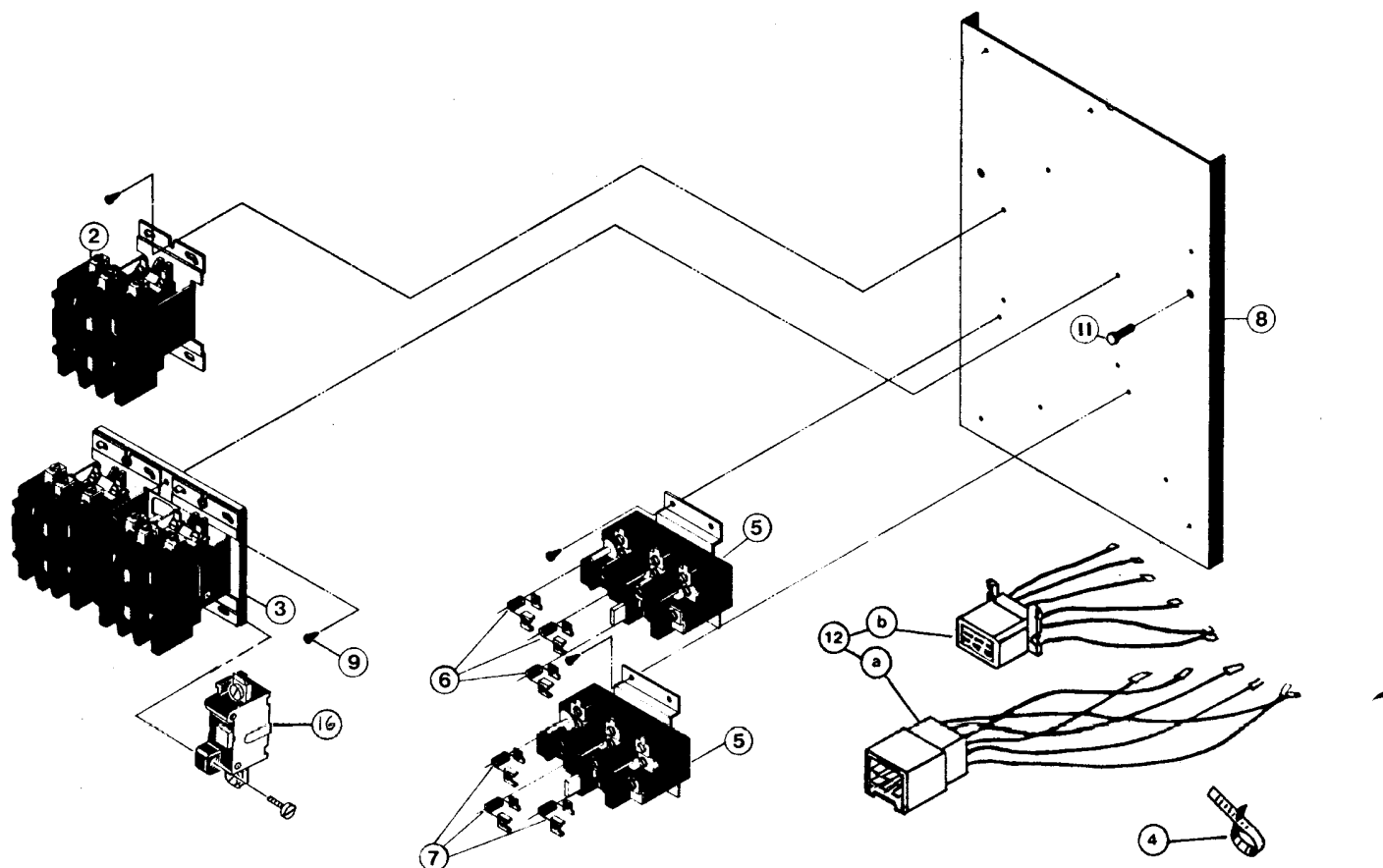

<u>Ref. No.</u>	<u>Part No.</u>	<u>Description</u>	<u>Ref. No.</u>	<u>Part No.</u>	<u>Description</u>
1		Timer, See Page 41	9	TU7733	#8-1/2" Self Drill Screw
2	*TU6965	Contactor 120 V. 60 Hz.	10		
	**TU6963	Contactor 208/240 V. 60 Hz.			
	***TU8727	Contactor 240 V. 50 Hz.			
3	*TU7252	Contactor 120 V. 60 Hz.	11	TU2793	1/4-20x3/4" Hex Hd. Screw
	**TU6964	Contactor 208/240 V. 60 Hz.	12	TU8715	Wiring-Plug Type (For Dryers W/O Transformer)
	***TU8728	Rev. Contactor 240V. 50 Hz.			
4	TU10579	Harness Clamp		TU8716	Wiring-Plug Type (For Dryers W/Transformers)
5	TU6774	Overload Unit (2 req'd.)			
6	****TU267900	Overload Heater (Fan)	12a	TU9692	Housing-Female
7	****TU267900	Overload Heater (Basket)	12b	TU9691	Housing-Male
8	TU6959	Panel Plate	13	RC349	1/2" Int. Tooth Lockwasher
			14	TU3209	#14x5/8 Pan Hd. M. Screw
			15	LB74	#14 Speed Nut
			16	TU12864	Anti-Dwell Switch

* TU7281 Contactor Coil only 120 V. 60 Hz.
 ** TU7282 Contactor Coil only 208/240 V. 60 Hz.
 *** TU8689 Contactor Coil only 240 V. 50 Hz.
 **** To order Overloader Heater, see chart on next page.

TABLE FOR ORDERING OVERLOAD HEATERS FOR OVERLOAD RELAYS

Properly sized overload heaters provide motor protection to the dryer. Improper heater size may allow the motor to be damaged, or could cause nuisance tripping.

Heater sizes are listed on the overload heater table below. To use the table, refer to the motor rating plate and locate the Full Load Amps (FLA), the Service Factor (S.F.), and the Ambient Temperature (Amb.).
 Example: Motor Rating Plate shows FLA = 3.8, S.F. = 1.15, and 60 Deg. C Amb.
 From the table, heater size is H-25. Order TU267900 - H25.

CAUTION: Overload Relays do not provide protection from short circuits. Short circuit protection is provided by a device such as a breaker or wall disconnect.

OVERLOAD HEATER TABLE
 Motor Full Load Amps (FLA)

Heater Size	S.F. = 1.00		S.F. = 1.15		S.F. GREATER Than 1.15
	40 Deg. C Amb.	60 Deg. C Amb. or More	40 Deg. C Amb.	60 Deg. C Amb. or More	40. Deg C Amb. or More
H-6	.69-.76	.55-.60	.62-.68	.50-.54	.69-.74
H-7	.77-.82	.61-.66	.69-.74	.55-.59	.75-.83
H-8	.83-.92	.67-.74	.75-.83	.60-.66	.84-.93
H-9	.93-1.03	.75-.83	.84-.93	.67-.74	.94-1.02
H-10	1.03-1.13	.84-.91	.94-1.02	.75-.81	1.03-1.16
H-11	1.14-1.29	.92-1.03	1.03-1.16	.82-.93	1.17-1.31
H-12	1.30-1.46	1.04-1.16	1.17-1.31	.94-1.05	1.32-1.45
H-13	1.47-1.61	1.17-1.29	1.32-1.45	1.06-1.16	1.46-1.63
H-14	1.62-1.81	1.30-1.45	1.46-1.63	1.17-1.30	1.64-1.80
H-15	1.82-2.00	1.46-1.60	1.64-1.80	1.31-1.44	1.81-1.96
H-16	2.01-2.18	1.61-1.74	1.81-1.96	1.45-1.57	1.97-2.22
H-17	2.19-2.47	1.75-1.97	1.97-2.22	1.58-1.77	2.23-2.43
H-18	2.48-2.70	1.98-2.16	2.23-2.43	1.78-1.94	2.44-2.55
H-19	2.71-2.83	2.17-2.27	2.44-2.55	1.95-2.04	2.56-2.81
H-20	2.84-3.12	2.28-2.50	2.56-2.81	2.05-2.25	2.82-2.99
H-21	3.13-3.32	2.51-2.66	2.82-2.99	2.26-2.39	3.00-3.43
H-22	3.33-3.81	2.67-3.05	3.00-3.43	2.40-2.74	3.44-3.90
H-23	3.82-4.33	3.06-3.49	3.44-3.90	2.75-3.12	3.91-4.28
H-24	4.34-4.76	3.48-3.80	3.91-4.28	3.13-3.42	4.29-4.86
H-25	4.77-5.40	3.81-4.32	4.29-4.86	3.43-3.89	4.87-5.45
H-26	5.41-6.06	4.33-4.84	4.87-5.45	3.90-4.36	5.46-6.13
H-27	6.07-6.81	4.85-5.45	5.46-6.13	4.37-4.90	6.14-6.79
H-28	6.82-7.55	5.46-6.03	6.14-6.79	4.91-5.43	6.80-7.72
H-29	7.56-8.58	6.04-6.86	6.80-7.72	5.44-6.17	7.73-8.48
H-30	8.59-9.42	6.87-7.54	7.73-8.48	6.18-6.78	8.49-9.65
H-31	9.43-10.72	7.55-8.58	8.49-9.65	6.79-7.72	9.66-10.70
H-32	10.72-11.99	8.59-9.59	9.66-10.70	7.73-8.63	10.8-12.3

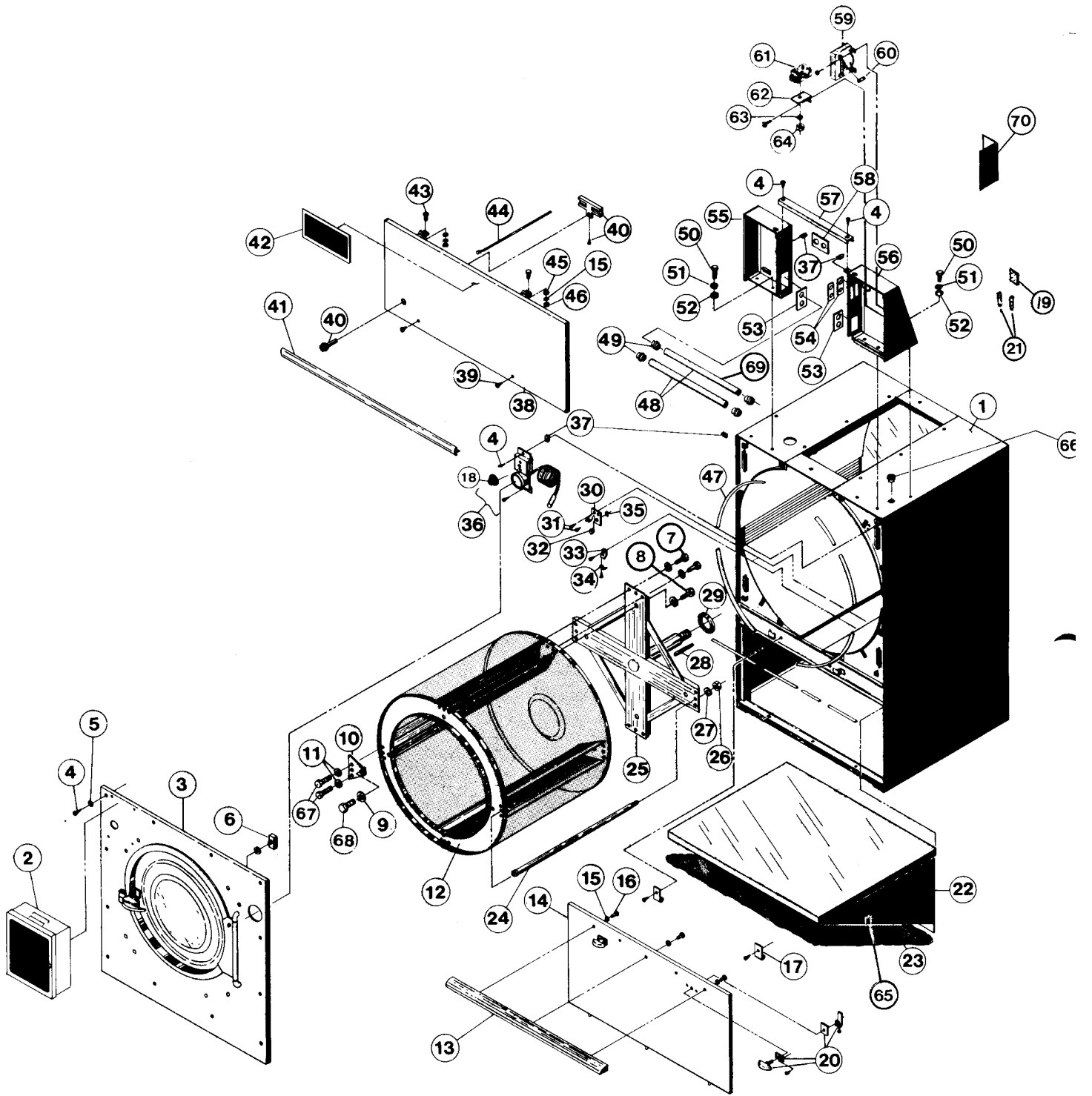

FRONT VIEW - ILLUSTRATED PARTS

<u>Ref. No.</u>	<u>Part No.</u>	<u>Description</u>	<u>Ref. No.</u>	<u>Part No.</u>	<u>Description</u>
1	TU9422	Jacket Weldment	33	TU5337	Thermostat Bulb Support
2	---	Control Box*	34	F646	5/16" Clamp
3	TU9623	"K" Door Panel*	35	TU3801	Speed Nut
	TU9717	"C" Door Panel*	36	TU6030	"C" Temperature Assembly
4	TU6854	#14x3/4" Pan Hd. Screw		TU9718	"K" Temperature Assembly
5	RC349	1/2" I.T. Lockwasher	37	LB74	#14 Speed Nut
6	FG140	Door Switch	38	TU9575	Access Door
7	TU2663	1/2"-20x2" Cap Screw	39	FG343	Screw Fastener
8	TU2665	5/8-28x2" Cap Screw	40	TU6808	Reset Button Assembly
9	TU5801	5/8" I.T. Lockwasher	41	TU9610	Chrome Trim
10	TU5397	Outside Rib Plate	42	TU8013	Cissell Nameplate "C"
11	OP251	1/2" I.T. Lockwasher		TU9591	Cissell Nameplate "K"
12	TU9609	"C" Basket Only	43	TU3479	#10-32x7/16" Tr. Hd. Sc.
	TU9743	"K" Basket Only	44	TU5739	Support Rod
	K325	"C" Basket/Spider Kit	45	P104	1/4" Cut Washer
	K319	"K" Basket/Spider Kit	46	TU2842	#10-32 Hex Nut
13	TU9444	Door Handle	47	TU5302	Sweep Sheet Gaskets
14	TU9472	Lint Trap Door Panel	48	TU9620	1/2" Greenfield Cable-32"
	TU9607	Lint Trap Dr. Complete	49	TU4790	Straight Connector, 1/2"
		Parts 13,14,15,16 & 20	50	TU3246	3/8"-16x1 Hex Hd. Screw
15	FB187	#10 Lockwasher	51	VSB134	3/8" Lockwasher
16	F557	#10-24x3/8" Rd. Hd. Scr.	52	IB140	3/8" Cut Washer
17	TU6159	Support Clips	53	TU9619	Conduit Plate
18	TU490	"C" Knob-Fahrenheit	54	TU8582	Ignition Box Plate
		"C" Knob-Centigrade	55	TU9519	Left Control Box
19	TU10596	Fuse Block	56	TU12839	Right Control Box
20	K169	Handle Assembly Kit	57	TU9522	Top Brace
21	TU10599	Fuse (1 Amp)	58	TU8580	Left Box Plate
22	TU10345	Lint Trap Hood Assembly	59	TU11622	Transformer w/Fuses
23	K121	Frame Only		TU9804	"K" Transformer (480V)
	K368	Screen Only	60	TU8738	Fuse
24	TU5911	Tie Rod	61	TU8599	Ignition Relay
25	K321	"C" Spider Assembly**	62	TU8709	Relay Bracket
	K322	"K" Spider Assembly**	63	M270	I.T. Lockwasher
26	TU2881	5/8"-18 Hex Nut	64	TU3400	Hex Nut
27	TU3418	5/8" Lockwasher	65	TU6160	Lint Screen Clip
28	TU9975	Worm Gear Key	66	TU9209	Snap Bushing
29	TU5290	Felt Seal	67	TU2662	1/2-20x1 1/2" Cap Screw
30	TU2486	"C" Thermostat Bracket	68	TU2664	5/8-18x1 1/2" Cap Screw
	TU9722	"K" Thermostat Bracket	69	504641292	1/2" Greenfield Cable-34"
31	TU7733	#8-18x1/2" Self Drill Screw	70	TU8036	Left Box Shield
32	TU2477	"C" Thermostat			

* See Separate Page for Exploded View.

** Consists of: Spider, Key, Jam Nuts, Felt Gasket & Washer

150 LB. LAUNDRY DRYER (Double Motor Models)

MODELS: L50KD42 } Gas, Steam
L50CD42 }

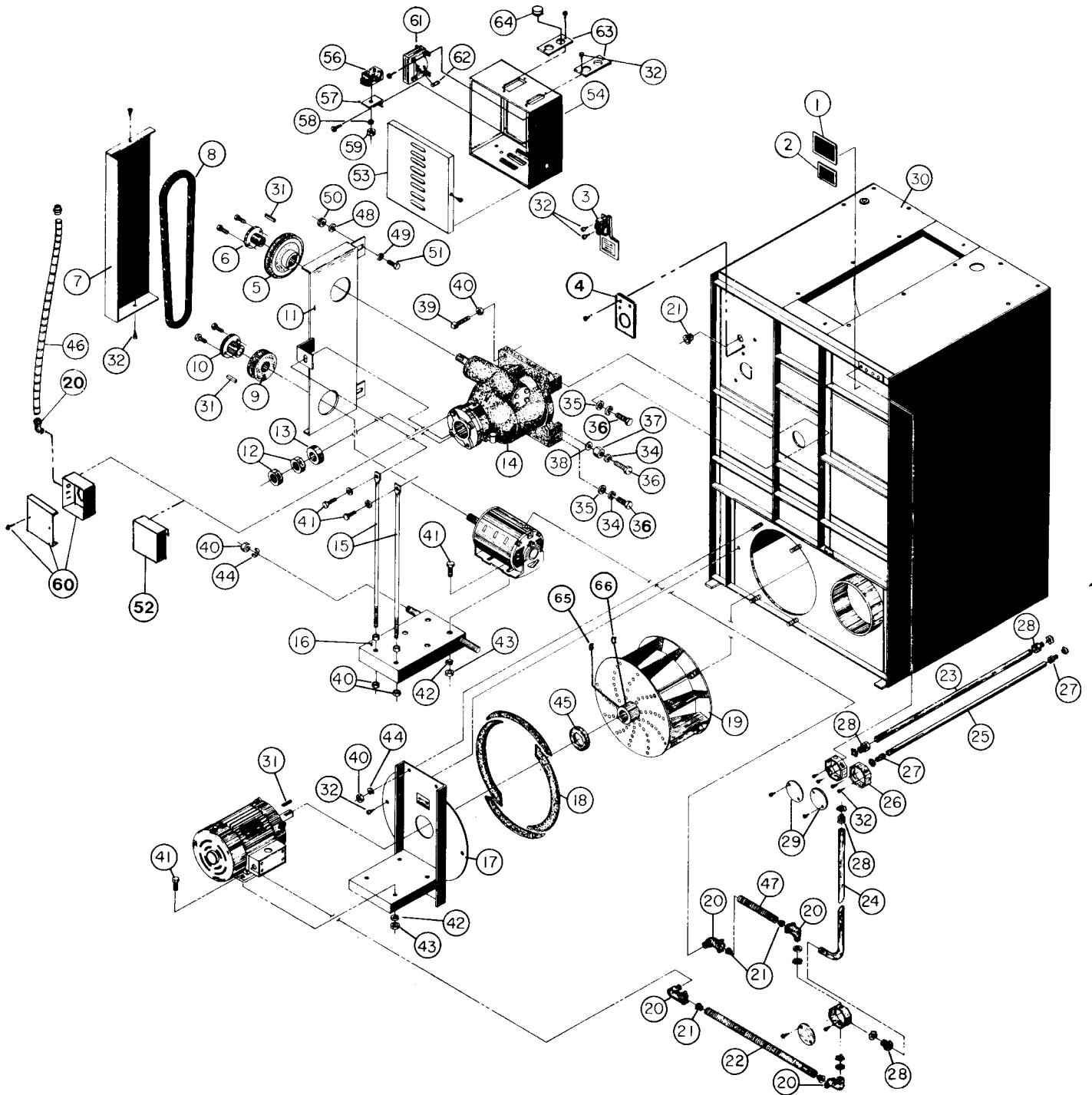

150 LB. LAUNDRY DRYER (Double Motor Models)

MODELS: L50KD42 Gas, Steam
L50CD42

Ref. Part			Ref. Part		
<u>No.</u>	<u>No.</u>	<u>Description</u>	<u>No.</u>	<u>No.</u>	<u>Description</u>
1	F1116	Rating Label	33	RC347	½-13x1¼ Hex Hd. Cap Screw
2	TU3583	Clearance Label	34	TU2831	½ Split Lockwasher
3	TU8206	Air Switch Assy.	35	TU1851	½ Flat Washer
4	TU9180	Air Switch Hole Plate	36	TU2195	½-13x1 3/4 Hex Hd. Cap Screw
5	TU9663	Gear Sheave (50/60 Hz.)	37	TU455	Cam Adjustment Nut
6	TU3807	Sheave Bushing	38	TU3575	7/8" I.T. Lockwasher
7	TU5668	Outside Belt Guard	39	TU5312	3/8"-16x3" Sq. Hd. Set Screw
8	TU2363	"V" Belt 5L500	40	TU4787	3/8-16 Hex Nut
9	TU9751	Motor Sheave - 60 Hz	41	TU5439	5/16"-18x3/4 Hex Hd. Cap Scr.
	TU6081	Motor Sheave - 50 Hz	42	TU2814	5/16" Split Lockwasher
10	TU2007	Sheave Bushing	43	C249	5/16 - 18 Hex Nut
11	TU9615	Inside Belt Guard	44	VSB134	3/8" Split Lockwasher
12	TU470	1-3/8 - 12 Hex Nut	45	TU108	Felt Seal
13	TU6633	Basket Shaft Washer	46	504641292	½" Greenfield Cable-30"
14	TU418	Gear Reducer	47	504641292	½" Greenfield Cable
15	TU5328	Belt Adjusting Rod			10½" Long
16	TU4626	Basket Motor Mount Weldment	48	TU2846	¼" Split Lockwasher
17	TU5658	*Motor & Fan Mount	49	TU2847	¼" Flat Washer
		Weldment (60 Hz.)	50	TU4934	¼"-20x7/16" Hex Nut
18	TU2473	Gasket Set	51	FB189	¼-20x1" Hex Hd. Screw
19	TU403	*Fan Wheel w/set Scr.(60Hz.)	52	TU7517	Shaft Cover "C" Only
20	TU4791	90° Elbow Connector	53	TU8194	Air Switch Box Cover
21	TU2372	Snap Bushing	54	TU8550	Air Switch Box W/A
22	504641292	½" Greenfield Cable-28" Lg.	55		
23	TU6026	Top Motor Conduit	56	TU8599	Igniter Relay
24	TU9567	Back Motor Conduit	57	TU8709	Relay Bracket
25	TU6028	Power Lead Conduit	58	M270	I.T. Lockwasher
26	500300644	Junction Boxes (3)	59	TU3400	#6-32x15/16" Hex Nut
27	TU7130	½" Straight Connector	60	TU10732	Housing Asm. "K" Only
28	TU7131	3/4" Straight Connector	61	TU11622	Transformer
29	SB170	Junction Box Cover	62	TU8738	Fuse
30	TU9422	Jacket Welded Assembly	63	TU8582	Conduit Plate
31	TU4684	Key	64	TU2490	7/8" Plug Button
32	TU7733	#8-18x½ Self Tap Screw	65	AT304	Sq. Hd. Set Screw
			66	TU4967	Allen Hd. Set Screw

* See next page for 50 Hz.

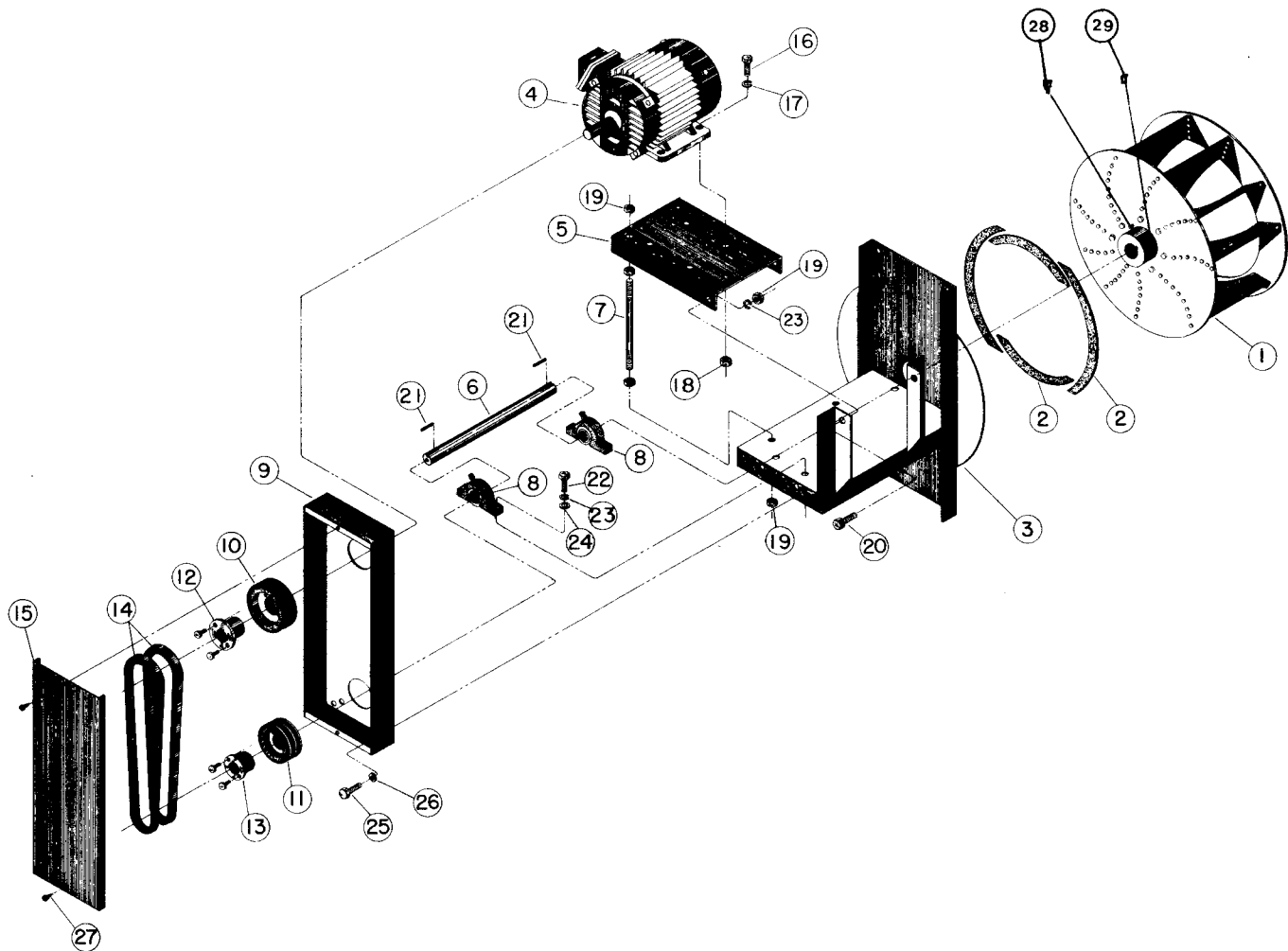

TU10088 MOTOR MOUNT ASSEMBLY 50 CYCLE

ALL HARDWARE SOLD ONLY IN PACKAGES OF 6

REF. NO.	PART NO.	DESCRIPTION	REF. NO.	PART NO.	DESCRIPTION
1	TU6086	50 Cycle Fan	16	TU4704	5/6"-24x1/4" Hex Head Screw
2	TU2473	Self-Sticking Gaskets (2 Sets Required)	17	TU2814	5/16" Split Lock Washer
3	TU5659	50 Cycle Motor Mount	18	V56	5/16"-24 Hex Nut
4	MTR219	Motor: Specify Motor Number & Voltage	19	TU4787	3/8"-16 Hex Nut
5	TU4706	Motor Mount Plate	20	TU3246	3/8-16x1" Hex Head Screw
6	TU1693	Jack Shaft	21	TU4684	1 1/2" Key
7	TU1950	Motor Support Rod (2 Required)	22	OP380	3/8"-16x1 1/2" Hex Head Screw
8	SB138	Pillow Block (2 Req'd)	23	VSB134	3/8" Split Lock Washer
9	TU4715	Belt Guard Weldment	24	IB140	3/8" Flat Washer
10	TU2008	Sheave 2AK46H	25	RC344	1/4"-20x3/4" Hex Head Screw
11	TU2009	Sheave 2AK39H	26	TU2847	1/4" Flat Washer
12	TU2007	H 7/8" Bushing	27	TU7733	#8x1/2" Self-Drillir Screw
13	TU3807	H 3/4" Bushing	28	AT304	Sq.Set Screw
14	TU3393	4L280 "V" Belt (2 Required)	29	TU4967	Allen Set Screw
15	TU4716	Belt Guard Cover			

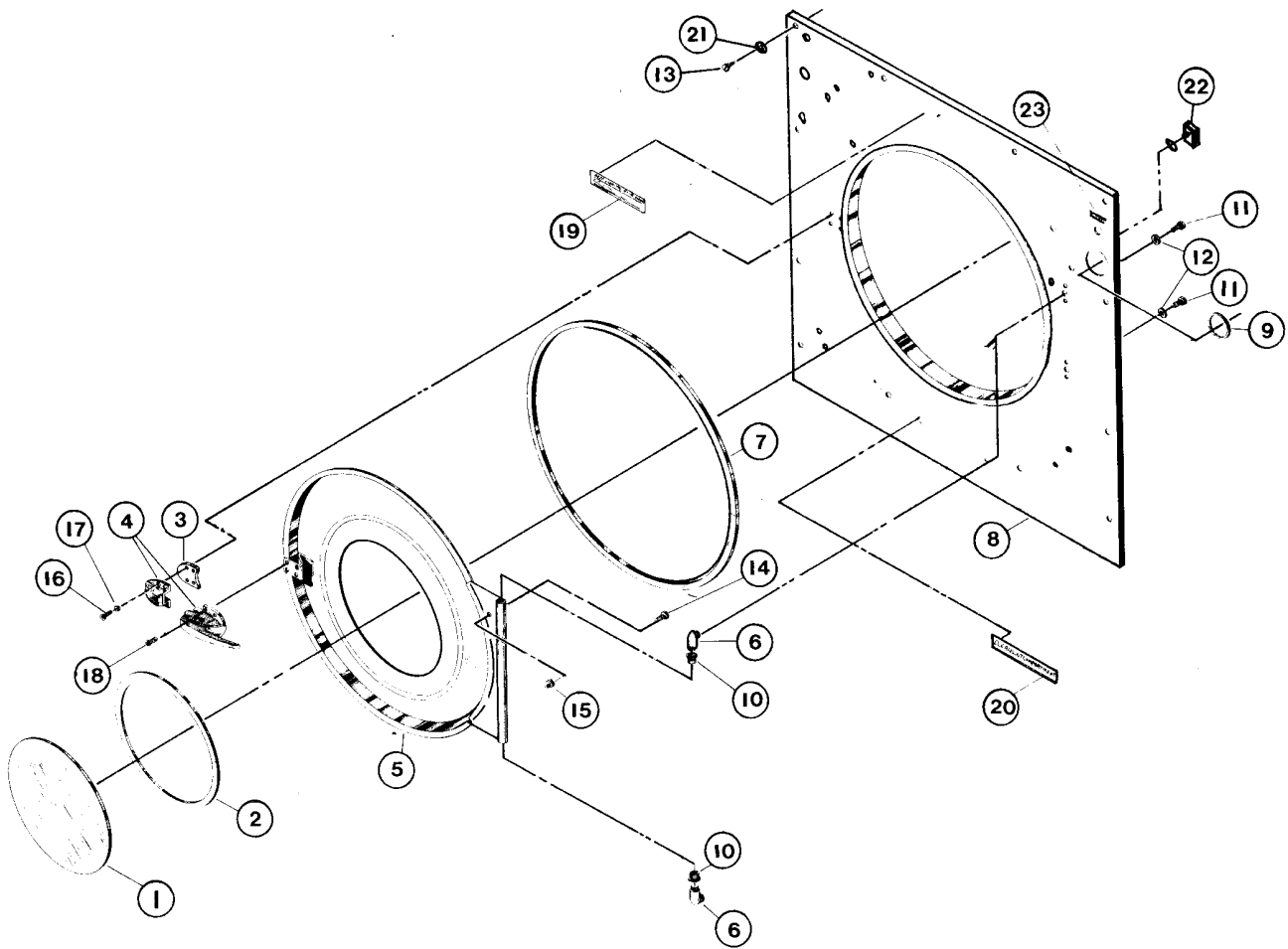

FRONT PANEL AND DOOR ASSEMBLY

TU9717 - "C" Model
 TU9623 - "K" Model

<u>Ref. No.</u>	<u>Part No.</u>	<u>Description</u>	<u>Ref. No.</u>	<u>Part No.</u>	<u>Description</u>
1	TU217	Door Glass	12	TU3212	5/16" I. T. Lockwasher
2	TU1692	Gasket	13	TU3209	#14X5/8" Pan Head Machine Screw
3	TU5503	Door Latch Spacer	14	TU4839	#10-32 x 3/8" Screw
4	TUA2319	Door Latch W/Keeper	15	TU4840	#10-32 Crown Nut
5	TU5500	Door W/A	16	TU2687	#8-1/2" Ph. Hd. Scrw.
6	TU2236	Hinge Post	17	TU3785	#8 Cup Ex. T. Lockwasher
7	TU5288	Door Seal	18	TU2686	#8-32X3/8" Ph. Hd. Scrw.
8	TU9719	Front Panel "C & K" *	19	TU7855	Instruction Label
9	TU2641	Thermometer Gasket	20	TU7858	Clean Lint.....Label
10	PIF172	Hinge Post Bearing	21	RC349	1/4" Lockwasher
11	TU2836	5/16"-32X3/8" Hex Scr.	22	FG140	Door Switch
			23	TU5458	Temp. Label "C" Only

* "K" Models - Order TU2490 - Plug Button
 for Front Panel hole.

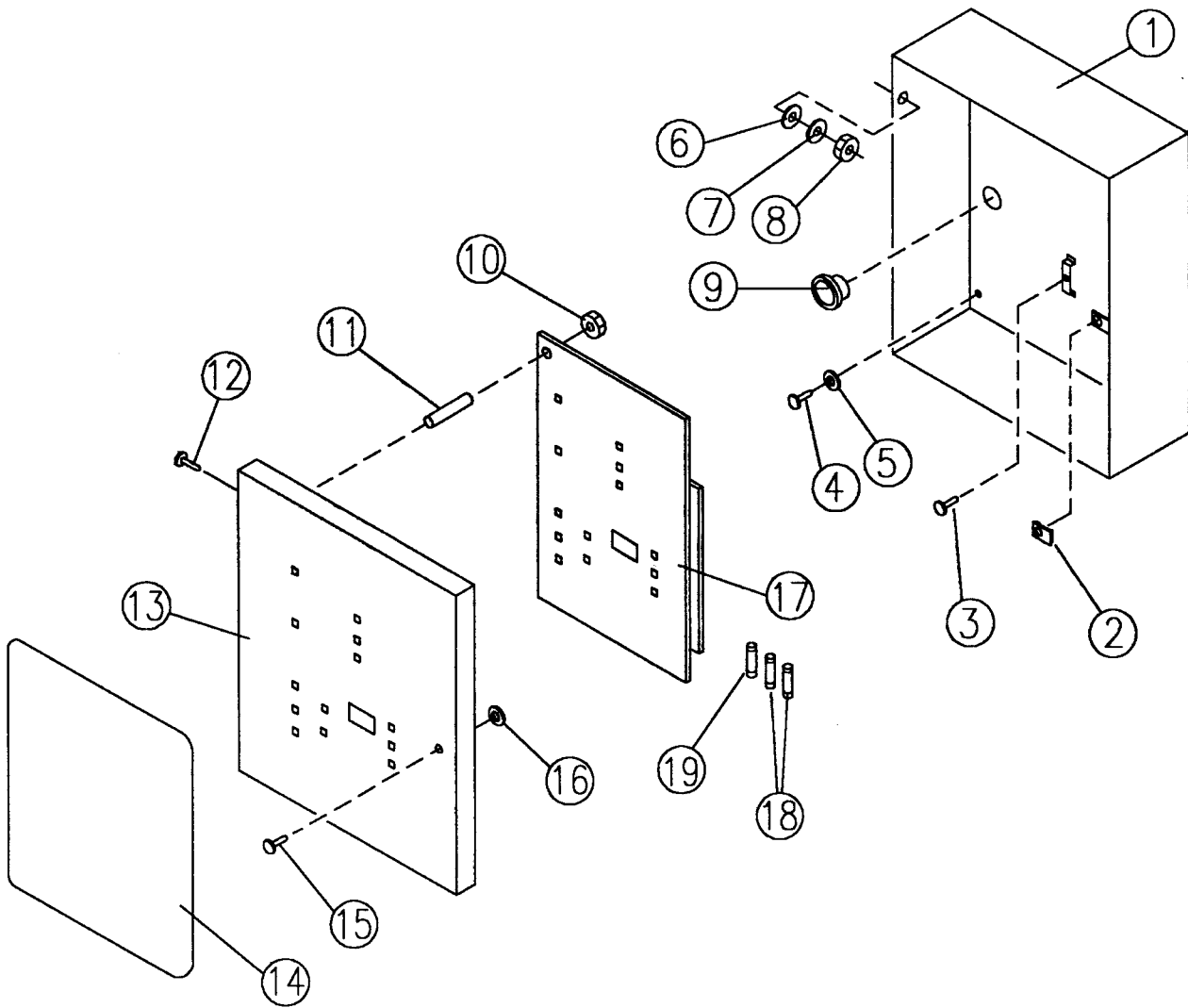

AUTOMATIC COMPUTER DRYING CONTROL BOX ASSEMBLY

Ref. No.	Part No.	Description
1	TU9584	Control Box
2	FG344	Speed Nut
3	TU7733	#8 x 1/2" Screw
4	CB36	1/4-20 x 1/2" Hex Hd. Bolt
5	TU2846	Washer
6	P104	1/4" Cut Washer
7	FB187	#10 Lockwasher
8	TU2842	#10-32 Hex Nut
9	TU9693	Snap Bushing, 2 1/2"
10	TU3400	#6-32 Hex Nut
11	TU12254	Spacer
12	TU3479	#10-32 Truss Hd. Screw
13	TU12843	Control Panel
14	TU12195	Control Panel Label
15	FG343	Screw Fastener
16	FG345	Retaining Washer
17	TU12105	Reversing Control Board
18	TU12863	Fuse, 5 Amp.
19	ET235	Fuse, 3/8 Amp.

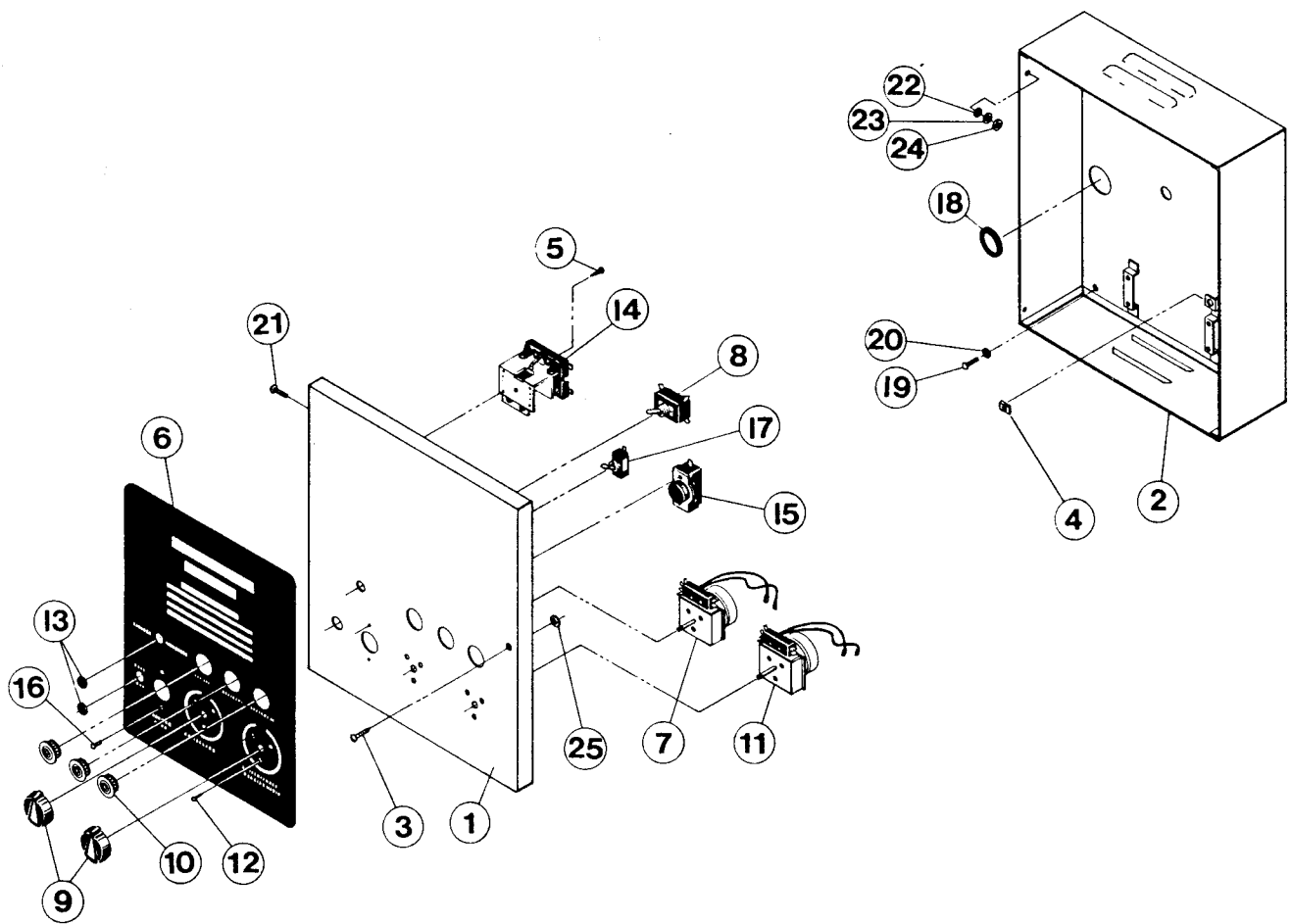

PERMANENT PRESS CONTROL BOX ASSEMBLY

TU9683 - 200-240V./ 60 Hz. Controls

TU9988 - 200-240V./ 50 Hz. Controls

TU10358 - 120V./60 Hz. Controls

Ref. No.	Part No.	Description	Ref. No.	Part No.	Description
1	TU9603	Control Panel	12	M262	#8-32 x 3/8" Screw
2	TU9584	Control Box	13	TU3805	15/32" Hex Lock Ring
3	FG343	Screw Fastener	14	TU1985	Relay, 220V.
4	FG344	Speed Nut		TU1984	Relay, 120V.
5	TU7733	#8 x 1/2" Screw	15	PT111	Push Button Switch
6	TU9681	Nameplate	16	ET208	#6-32 x 1/4" Pan Hd. Screw
7	TU5842	60 Min. Timer, 220V./60 Hz.	17	FG147	Toggle Switch, Rev.
	TU6109	60 Min. Timer, 120V./60 Hz.	18	TU9693	Bushing
	TU6083	60 Min. Timer, 220V./50 Hz.	19	CB36	1/4"-20 x 1/2" Screw
8	TU264	Toggle Switch	20	TU2846	Washer
9	TU2555	Knob Assembly	21	TU3479	#10-32 x 7/16" Truss Screw
10	M454	Amber Lamp, 220V.	22	P104	1/4" Cut Washer
	M102	Amber Lamp, 120V.	23	FB187	#10 Lockwasher
11	TU5843	15 Min Timer, 220V./60 Hz.	24	TU2842	#10-32 Hex Nut
	TU6110	15 Min Timer, 120V./60 Hz.	25	FG345	Retaining Washer
	TU6082	15 Min Timer, 220V./50 Hz.			

Air Switch Assembly

AIR SWITCH ASSEMBLY-TU8206

REF NO.	PART NO.	DESCRIPTION
1	F888	"E" Ring
2	TU2463	Actuator Arm
3	TU3476	Air Switch Decal
4	TU1771	#6 Tinnerman Nut
5	TU8155	Air Switch
6	TU1770	Insulator
7	TU8171	Air Switch Bracket
8	TU7733	#8-18x $\frac{1}{2}$ " Self-Drilling Screw
9	TU3219	#6x1" Rd. Hd. S.M.S.

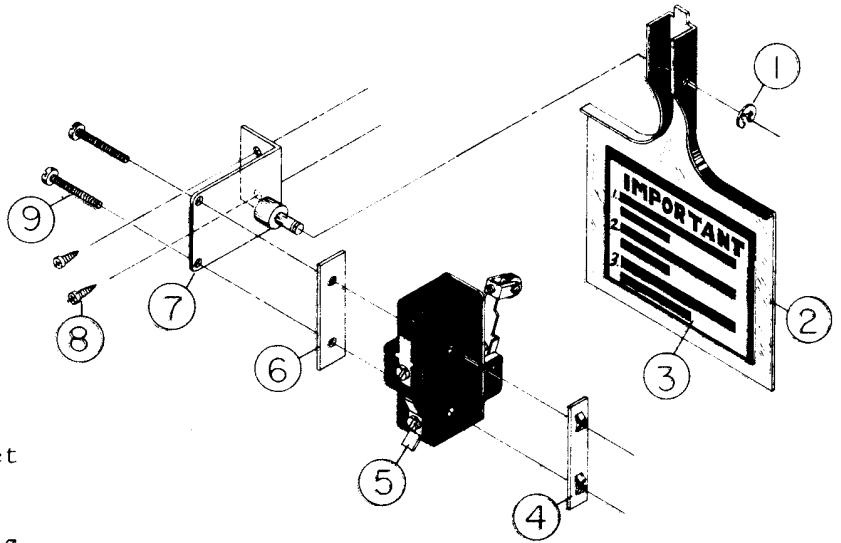

Thermistor Assembly

PROMPTER MODELS ONLY

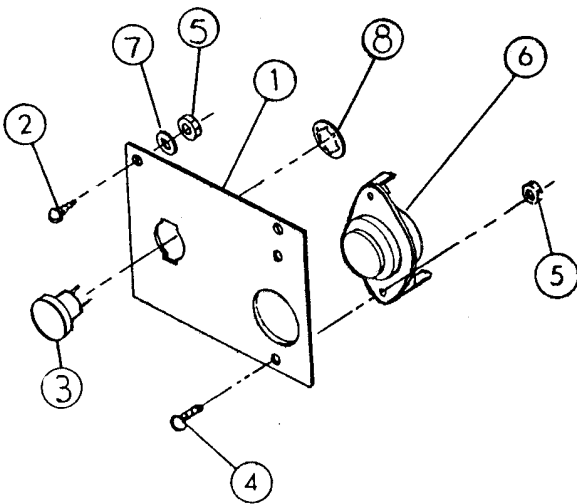

Ref. No.	Part No.	Description
1	TU9720	Bracket
2	LB291	#6 - 32 x 3/8" Screw
3	TU2477	High Limit Thermostat
4	TU3624	#6 Machine Screw
5	TU3400	#6 Hex Nut
6	TU11991	Thermistor
7	AT368	#8 Lockwasher
8	TU3801	Speed Nut

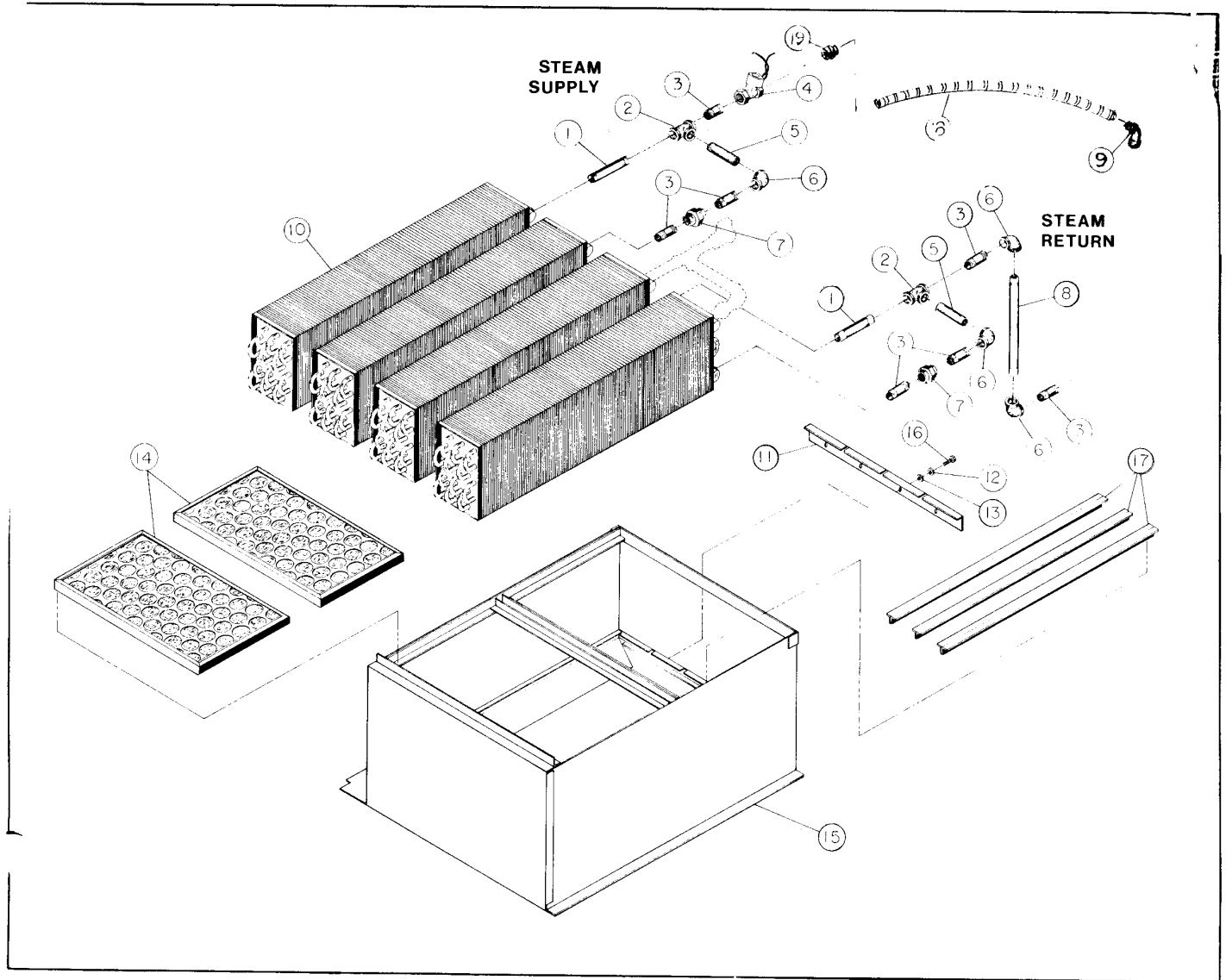

150 LB. STEAM BONNET ASSEMBLY - TU9920

Ref. No.	Part No.	Description	Ref. No.	Part No.	Description
1	TU4610	3/4x5" Pipe Nipple (4 ea.)	13	TU2847	Flat Washer (4 ea.)
2	TU4597	3/4" Tee (4 ea.)	14	TU9953	Air Filter 20"x24"x1" (2 ea.)
3	TU4608	3/4"x2" Pipe Nipple (14 ea.)	15	TU9873	Steam Bonnet Weldment
4	TU5924	* Steam Solenoid Valve (2 ea.)	16	CB36	1/4-20x1/2 Hex Bolt (4 ea.)
5	TU4620	3/4"x4 1/2" Pipe Nipple (4 ea.)	17	TU9889	Coil Support Angle (3 ea.)
6	TU4605	3/4" Elbow (8 ea.)	18	504641292	1/2" Greenfield Cable Right Side - 39" Left Side - 33"
7	TU4600	3/4" Union (4 ea.)	19	TU4790	Straight Connector
8	TU4599	3/4"x18" Pipe Nipple (2 ea.)	20	TU4791	90° Connector
9					
10	TU1699	Steam Coils (4 ea.)			
11	TU9890	Hold Down Bracket			
12	TU2846	1/4" Split Lockwasher (4 ea.)			

* Replacement Coils: TU6763 (240 V.)
 TU5939 (208 V.)
 TU10289 (200 V.)

Gas Bonnet & Burner Assembly - Models C & K

COMPLETE ASSEMBLY - TU9624

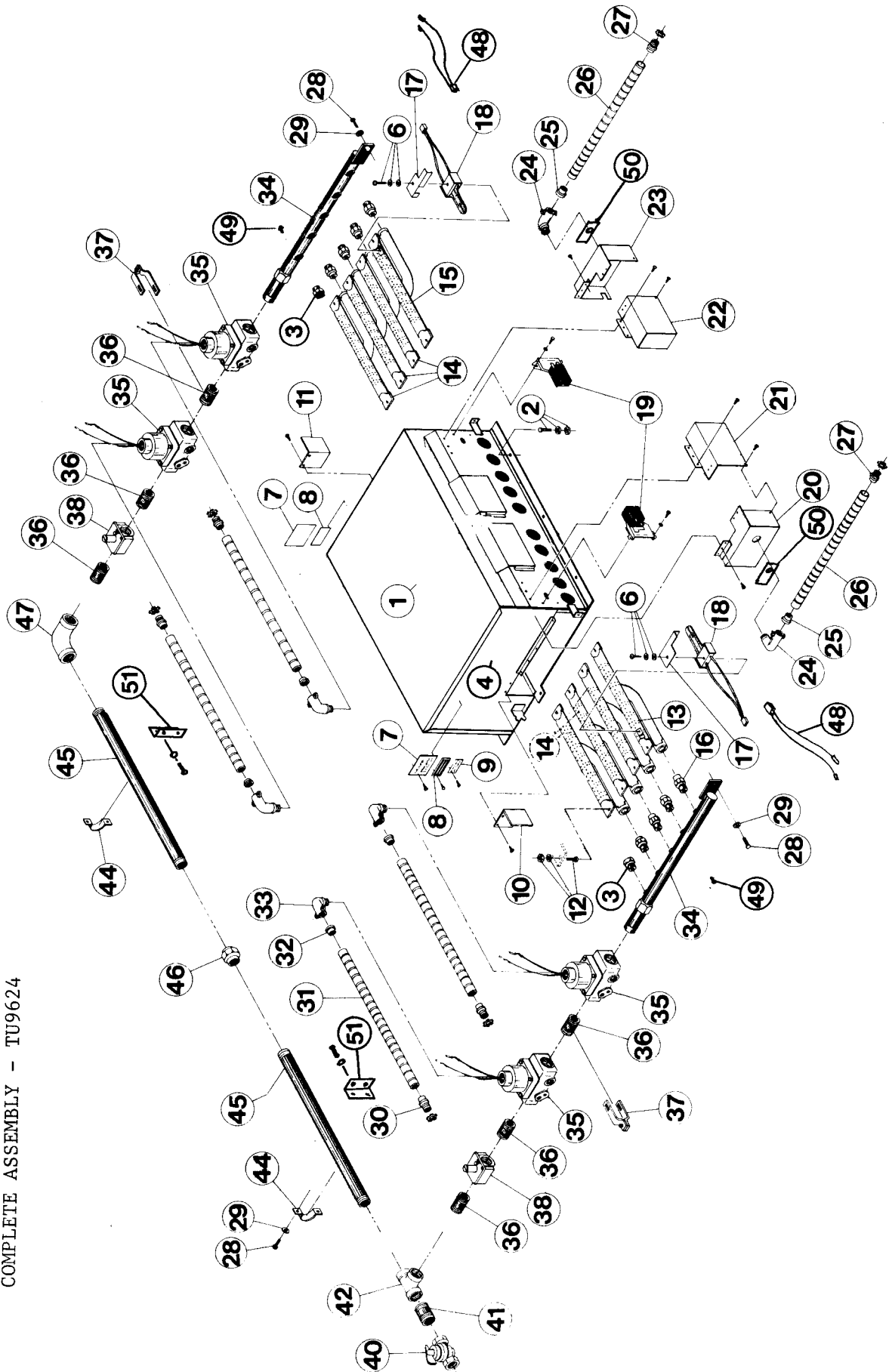

Ref. No.	Part No.	Description	Ref. No.	Part No.	Description
1	TU10241	Bonnet Top Only	24	TU4791	1/2" 90° Connector
2	TU3124	3/8" Hex Hd. Bolt	25	C171	1/2" Bushing
	VSBI34	3/8" Lockwasher	26	504641292	1/2" Greenfield Cable - 34" Lg.
	IBI40	3/8" Flat Washer	27	TU4790	1/2" Straight Connector
3	TU10946	Manifold Plug	28	CB36	1/2-20x1/2 Hex Hd. Screw
4	TU9526	Bonnet Welded Assembly	29	TU2846	1/4" Lockwasher
5			30	F875	3/8" Straight Connector
6	TU3416	#8 x 1 1/4 Screw	31	504600249	3/8" Greenfield Cable - 20" Lg.
	M271	Washer	32	C170	3/8" Bushing
	P104	Cut Washer	33	F876	3/8" 90° Connector
7	TU9585	Rating Nameplate	34	TU9614	Manifold Assembly
8	TU8613	Igniter Instructions	35	TU6557	Gas Valve *
9	TU8645	Installation Instructions	36	OP290	1/2" Pipe - 2" Lg.
10	TU9539	Rear Heat Shield	37	TU2226	Mounting Bracket
11	TU9538	Front Heat Shield	38	TU7686	Gas Regulator
12	TU4934	1/4"-20 Hex Nut	39		
	TU2846	1/4" Lockwasher	40	TU9654	Gas Cock
	CB36	1/4-20x1/2" Hex Hd. Screw	41	TU9656	1" Pipe - 4" Lg.
13	TU9437	Rear Ignition Burner	42	TU10622	Pipe Tee - 1" X 1/2" X 3/4"
14	TU9423	Gas Burners	43		
15	TU9411	Front Ignition Burner	44	TU9657	Pipe Clamp
16	TU3539	Orifice	45	TU4599	3/4" Pipe - 18" Lg.
17	TU9540	Igniter Heat Shield	46	TU4600	Pipe Union
18	TU8596	Norton Igniter	47	TU10623	Elbow - 1/2" X 3/4"
19	TU8598	Radiant Sensor	48	TU8605	Molex Connector
	602102180	#8x1/2" Hex Hd. Slot Screw	49	TU2224	1/8" Plug (For Manifold Test)
20	TU9549	Rear Igniter Cover	50	TU8582	Conduit Plate
21	TU9569	Rear Sensor Cover	51	TU9557	Pipe Support Bracket
22	TU9552	Front Sensor Cover			
23	TU9553	Front Igniter Cover			

NOTE: FOR CONVERSION FROM NATURAL GAS TO PROPANE GAS

1. Order:

- 8 ea. TU3539 Orifice with No. 46 drill size.
- 2 ea. TU4651 Gas Pipe Nipple 1/2" X 6".
- 1 ea. TU7664 L.P. Gas Tag.

2. Instructions:

- A. Remove 2 gas regulators (TU7686) 1 front, 1 rear.
- B. Remove 4 gas pipe nipples (OP290) located on each side of regulators.
- C. Replace the regulators and 2" pipes with the 6" gas pipe nipples (TU4651).
- D. Replace the natural gas orifices with the propane gas orifices (No. 46).
- E. Fasten the L. P. gas tag to gas manifold.

Specifications:

- Propane Gas - 1.53 Specific Gravity
- Calorific Value- 2,500 B.T.U./Cu. Ft.
- 11 inches water column gas pressure
- Gas Input - 46,250 B.T.U./Hour per Burner
- 370,000 B.T.U./Hour Total.

*TU9208 - Valve Coil Replacement

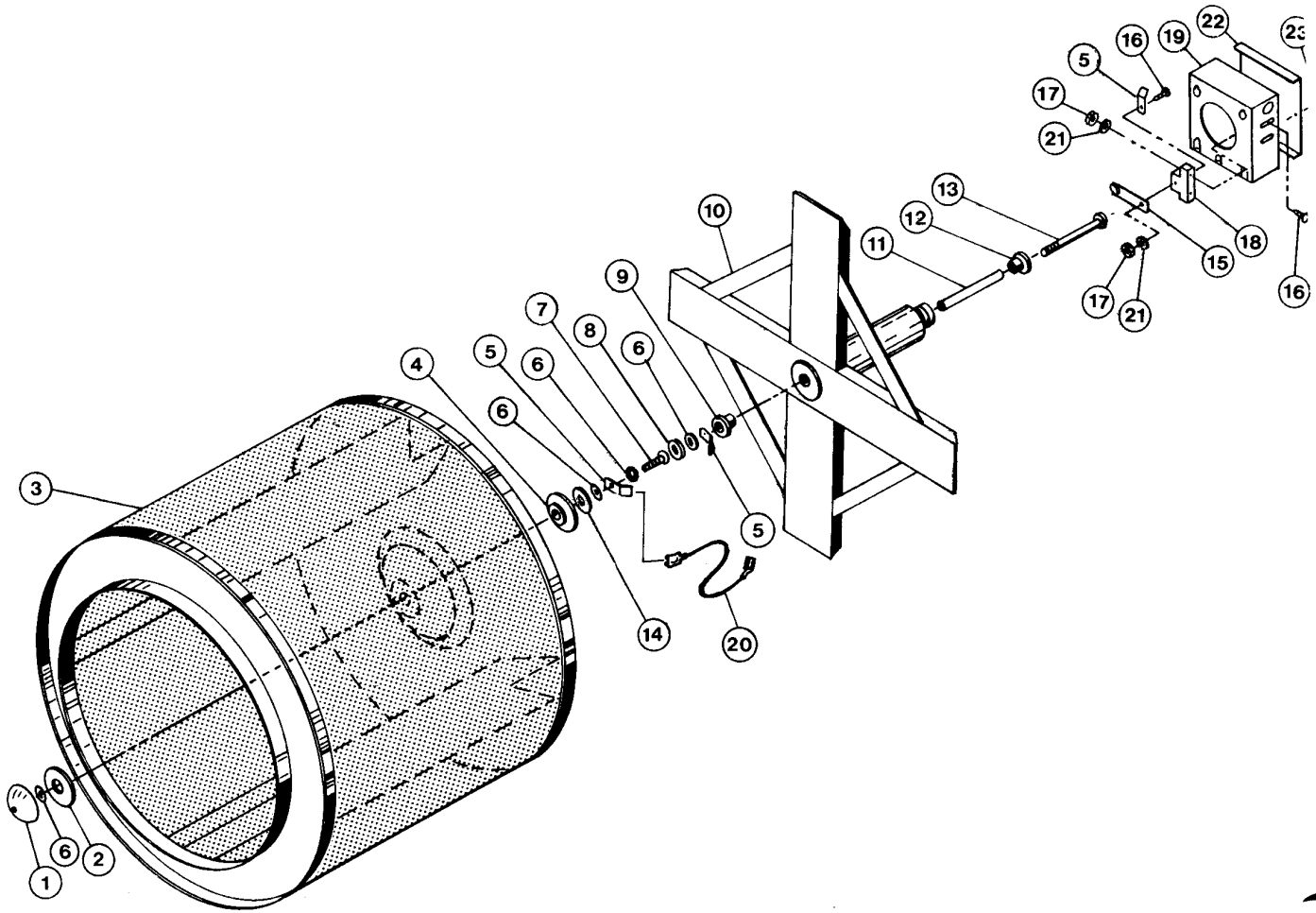

"K" MODELS

PROMPTER BASKET SENSOR ASSEMBLY

<u>Ref. No.</u>	<u>Part No.</u>	<u>Description</u>
1	TU9616	Sensor Tip
2	TU9618	Insulator Washer
3	TU9743	"K" Basket Assembly
4	TU9617	Insulating Disc
5	AT388	Terminal Connector
6	TU9910	Ex. T. Lockwasher
7	TU9949	#8-32X7/8" Slot Hx.Hd.Bolt
8	TU3400	#6-32 Brass Hex Nut
9	TU9621	Rod Insulator
10	TU9451	"K" Spider W/A Only
11	TU9756	Insulating Sleeve
12	TU9621	Rod Insulator
13	TU9754	Conductor Rod
14	TU9944	Washer
15	TU9660	Wiper Strip & Button Assembly
16	RC353	Machine Screw #8-32 x 2/4"
17	TU3266	Hex Nut
18	TU10915	Wiper Insulator
19	TU10916	Wiper Housing
20	TU9628	Jumper Wire
21	M271	I.T. Lockwasher
22	TU10917	Housing Cover
23	TU7733	Self-Drill Screw

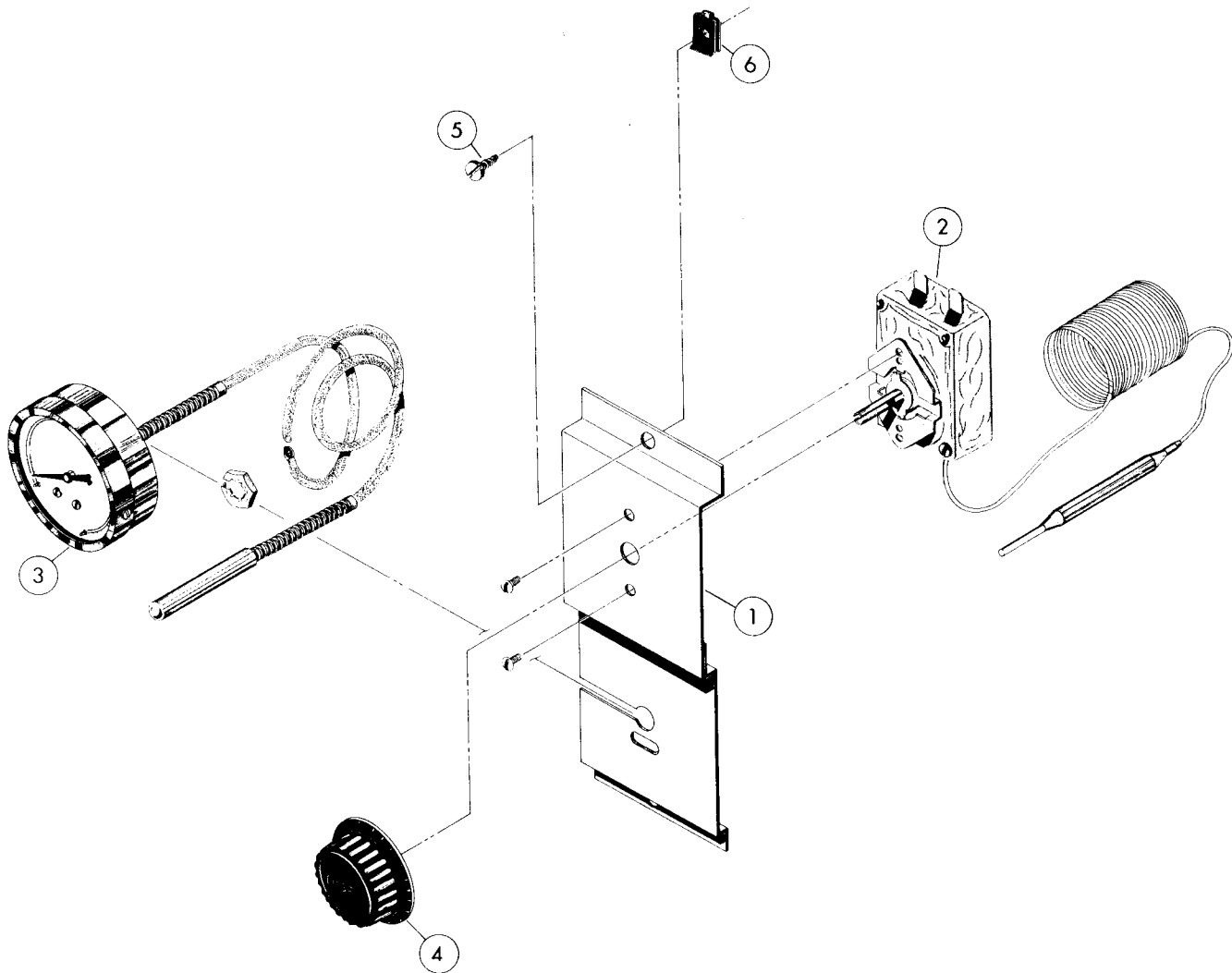

TEMPERATURE ASSEMBLY

TU6030 - "C" Model - Consists of Ref. No. 1,2,3

TU9718 - "K" Model - Consists of Ref. No. 1,3

<u>Ref. No.</u>	<u>Part No.</u>	<u>Description</u>
1	TU5530	Mounting Bracket
2	TU1980	Thermostat
3	TU3593	Thermometer
	TU3816	Lens Replacement (Texas Gage only)
	TU8475	Lens Replacement (Marshaltown Inst. only)
	TU11193	Lens Replacement (Weiss Only)
4	TU490	Thermostat Knob - Fahrenheit
	TU491	Thermostat Knob - Centigrade
5	TU3209	#14x5/8" S.M.S.
6	Lb74	#14 Tinnerman Clip

TROUBLE	CAUSE	REMEDY
Basket motor runs, but basket will not revolve	V-Belt Broken	Replace V-Belt.
	V-Belt Loose	Adjust Belt Tension.
	Motor pulley loose	Tighten set screw.
	Basket overloaded	Remove load.
Dryer noisy or vibrating	Not leveled	Check manual for proper leveling procedures.
	Fan out of balance	Accidental damage to the fan blade can change the dynamic balance. Damaged fans should be replaced.
	Basket rubbing	Adjust basket clearance.
	V-Belt sheaves	Tighten set screws, make sure sheaves are in proper alignment.
	Belt	Adjust belt tension.
	Foreign objects	Occasionally screws, nails, etc. will hang in the basket perforations and drag against the sweep sheets surrounding the basket. Such foreign objects should be removed immediately.
Dryer runs but no heat Note: This dryer has two ignition systems, valves, etc. Be sure to check both systems.	Incorrect voltage	Check for correct control voltage - 120V.
	No voltage	Check power supply, check secondary voltage on transformer and check wiring and wiring diagram.
	Silicon carbide igniter will not glow - red	Broken or defective igniter--replace.
	Light red silicon carbide igniter	Low amperage-not hot enough. Low Voltage.
	Defective igniter time delay relay	Replace relay.
	Lint door open	Close lint door.
	Defective gas valve	Replace coil assembly.
	Gas turned off	Turn manual gas valve " <u>on</u> ."

TROUBLE	CAUSE	REMEDY
Dryer runs but no heat	Line fuse or heater circuit fuse blown to unit	Replace fuse.
	Defective door switch	Replace door switch.
	Silicon carbide igniter not igniting gas	Replace gas valve or radiant sensor or low voltage.
	Air switch not operating	Clean out lint compartment daily. Check back draft damper for foreign objects, lint accumulation or other causes that may prevent damper from opening. Check duct work for lint build-up. Check installation sheet to insure that duct work and make up air openings are adequately sized. Check exhaust outlet. If a screen has been improperly installed on the outlet, it may be clogged with lint or frozen over in winter. Never install a screen on the exhaust outlet. Vacuum within dryer drops to .09 inches of water column, or less, for normal operation of dryer, vacuum reading (in inches of water column) should range between .15 and .3 inches. Vacuum reading can be made with a vacuum U-gauge by removing a sheet metal screw in the front panel of dryer, and inserting the rubber tube of the vacuum gauge into screw opening.
	Air switch out of adjustment	See air switch adjustment sheet in service manual.
	Air switch defective	Replace air switch.
	Gas pressure too low	Check manifold pressure and adjust to pressure specified on rating plate. If this pressure cannot be obtained, have gas supplier check main pressure.
	Improper orifice	Dryer is orificed for type of gas specified on rating plate. Check with gas supplier to determine specifications for gas being used. If different from rating plate, contact factory and obtain proper orifices.
	Electric power to heating unit turned off	Turn power on.
Line fuse or heater circuit fuse blown to unit	Replace fuse.	

TROUBLE	CAUSE	REMEDY
Dryer runs but no heat	Defective relay	Replace relay.
	Defective thermostat	Replace thermostat.
	Defective safety overload thermostat	Replace thermostat.
	Lint compartment door open	Close door.
Main burners burning improperly	Burner air shutters closed	Open for blue flame.
	Dirt in burner	Blow out.
	Gas pressure too high	Check rating plate for correct gas pressure.
	Orifice too large	Send to factory for correct orifices.
	Restricted or blocked exhaust	Clean exhaust.
Main burner cycling on and off	Radiant sensor	Clean window or move sensor $\frac{1}{4}$ " closer to igniter.
Low gas flame or high gas flame	Incorrect main burner orifices	Replace orifices--check factory for correct size.
Dryer too hot	Incorrect main burner orifice	Replace orifices--check factory for correct size.
	Inadequate make-up air	Make up air must be 4 to 6 times the exhaust area of the dryer.
	Lint accumulated	Remove lint.
	Exhaust duct dampers	Must be full open or replace.
	Gas pressure too high	Adjust gas pressure as specified on rating plate.
	Partially restricted or inadequately sized exhaust system	Check installation sheet in service manual for recommended sizes. Check for and remove obstructions or lint build up from duct work. Never use smaller size exhaust duct. Always use larger size exhaust duct.
	Defective thermostat	Replace thermostat.

TROUBLE SHOOTING CHART

TROUBLE	CAUSE	REMEDY
Motors will not start	No Power	Check fuses on circuit breakers. Make sure main control switch is <u>on</u> .
	Incorrect power	Check power source: voltage, phase, and frequency must be the same as specified on electrical rating plate.
	Time off	Turn timer clock wise to desired time setting.
	Loose wiring connections	Check wire connections in electrical box on rear of Dryer.
	Defective starting relay	Check coils and contacts.
Motor tripping on thermal overload	Low voltage	Check voltage at motor terminals. Voltage must be within (plus or minus) 10% of voltage shown on motor rating plate--it not, check with local power company for recommended corrective measures.
	Inadequate wiring	Check with local power company to insure that wiring is adequately sized for load.
	Loose connections	Check all electrical connections and tighten any loose connections.
	Inadequate air	Check installation sheet in service manual for recommended make up air openings.
	Poor housekeeping	Clean lint accumulation on and around motors.
Basket motor will not run	Loading door open	Close door.
	Door switch out of adjustment	Adjust switch by removing cover and bend actuator lever to clear switch button 3/8" with cover in place.
	Defective door switch	Replace switch.
	Defective basket motor contactor	Replace contactor.
Basket will not reverse	Reversing Timer	Adjust timer(see page in Maintenance section),
		Check timer to see if working.

TROUBLE	CAUSE	REMEDY
Dryer does not stop at end of time period (6)	Defective timer	Replace timer.
Dryer runs no steam to coils	Valve closed	Check all valves in steam supply and return--make sure they are open.
	Steam trap blocked	Remove and clean. Replace if defective.
	Solenoid valve	On dryers using solenoid temperature control, check operation of solenoid valve by advancing thermostat.
	Thermostat	On dryers using solenoid temperature control, thermostat controls operation of solenoid valve. If defective, replace thermostat.
	Check valve installed incorrectly	Check for inlet and outlet marking on check valve, and invert if necessary.
	Strainer clogged	Remove plug and blow down strainer or remove and clean thoroughly if heavily clogged.
Water in steam line	Steam piping installed incorrectly	Check piping per steam installation in instructions.
	Trap not functioning	Check trap for size and capacity. If dirty and sluggish, clean thoroughly or replace. Check return line for high back pressure, or another trap charging against the trap functioning improperly.
Basket does not reverse	Reversing timer	Check timer to see if operating.
	Reversing timer	Adjust timer (See Furnas control sheet)