



SERVICE MANUAL

36CD30

DRYCLEANING

DRYER

REVERSING & NON-REVERSING
STEAM HEATED
50 cy. 60 cy.

•INSTALLATION

•OPERATION

•SERVICE

•MAINTENANCE

CISSELL MANUFACTURING COMPANY
LOUISVILLE, KENTUCKY. U.S.A.

MAN 5
11/84

PRINTED IN U.S.A.

WARRANTY

The Cissell Manufacturing Company, (Cissell) warrants all new equipment (and the original parts thereof) to be free from defects in material or workmanship for a period of one (1) year from the date of sale thereof to an original purchaser for use, except as hereinafter provided. With respect to non-durable parts normally requiring replacement in less than one (1) year due to normal wear and tear, including, but not limited to, cloth goods, valve discs, hoses and iron cords, and with respect to all new repair or replacement parts for Cissell equipment for which the one (1) year warranty period has expired or for all new repair or replacement parts for equipment other than Cissell equipment, the warranty period is limited to ninety (90) days from date of sale. The warranty period on each new replacement part furnished by Cissell in fulfillment of the warranty on new equipment or parts shall be for the unexpired portion of the original warranty period on the part replaced.

With respect to electric motors, coin meters and other accessories furnished with the new equipment, but not manufactured by Cissell, the warranty is limited to that provided by the respective manufacturer.

Cissell's total liability arising out of the manufacture and sale of new equipment and parts, whether under the warranty or caused by Cissell's negligence or otherwise, shall be limited to Cissell repairing or replacing, at its option, any defective equipment or part returned f.o.b. Cissell's factory, transportation prepaid, within the applicable warranty period and found by Cissell to have been defective, and in no event shall Cissell be liable for damages of any kind, whether for any injury to persons or property or for any special or consequential damages. The liability of Cissell does not include furnishing (or paying for) any labor such as that required to service, remove or install; to diagnose trouble; to adjust, remove or replace defective equipment or a part; nor does it include any responsibility for transportation expense which is involved therein.

The warranty of Cissell is contingent upon installation and use of its equipment under normal operating conditions. The warranty is void on equipment or parts; that have been subjected to misuse, accident, or negligent damage; operated under loads, pressures, speeds, electrical connections, plumbing, or conditions other than those specified by Cissell; operated or repaired with other than genuine Cissell replacement parts; damaged by fire, flood, vandalism, or such other causes beyond the control of Cissell; altered or repaired in any way that affects the reliability or detracts from its performance, or; which have had the identification plate, or serial number, altered, effaced, or removed.

No defective equipment or part may be returned to Cissell for repair or replacement without prior written authorization from Cissell. Charges for unauthorized repairs will not be accepted or paid by Cissell.

CISSELL MAKES NO OTHER EXPRESS OR IMPLIED WARRANTY, STATUTORY OR OTHERWISE, CONCERNING THE EQUIPMENT OR PARTS INCLUDING, WITHOUT LIMITATION, A WARRANTY OF FITNESS FOR A PARTICULAR PURPOSE, OR A WARRANTY OF MERCHANTABILITY. THE WARRANTIES GIVEN ABOVE ARE EXPRESSLY IN LIEU OF ALL OTHER WARRANTIES, EXPRESS OR IMPLIED. CISSELL NEITHER ASSUMES, NOR AUTHORIZES ANY PERSON TO ASSUME FOR IT, ANY OTHER WARRANTY OR LIABILITY IN CONNECTION WITH THE MANUFACTURE, USE OR SALE OF ITS EQUIPMENT OR PARTS.

For warranty service, contact the Distributor from whom the Cissell equipment or part was purchased. If the Distributor cannot be reached, contact Cissell.

INDEX

WARRANTY.....	Page 1
SPECIFICATION.....	Page 4
INSTALLATION.....	Page 5-10
SERVICE AND MAINTENANCE.....	Page 11-12
PARTS AND HARDWARE.....	Page 13-27

DO NOT PUT INTO THIS DRYER FLAMMABLE ITEMS SUCH AS:

**BABY BED MATTRESSES
THROW RUGS
UNDERGARMENTS (Brassieres, etc.)**

AND OTHER ITEMS

**WHICH USE RUBBER AS A PADDING OR BACKING!
RUBBER EASILY OXIDIZES CAUSING EXCESSIVE HEAT
AND POSSIBLE FIRE. FLAMMABLE ITEMS SHOULD BE AIR DRIED.**

GENERAL INFORMATION

The Cissell 36" CD30 drycleaning dryer consists of a basket 36" in diameter by 30" in depth placed at a convenient height - with a maximum capacity of 50 pounds dry-weight. When operator opens door, basket stops; exhaust fan continues to run, thus drawing outside air into basket through open door. **THIS IS IMPORTANT IN LOADING AND UNLOADING.** The continuous fan operation during loading and unloading provides a continuous withdrawal of volatile vapors and prevents a blast of hot air or vapors into operator's face.

You can expect fast drying and complete deodorization from a Cissell 30BD30 dry-cleaning dryer. Hot, dry air is properly and effectively moved through basket and exhausted through a lint trap to atmosphere; an eight-stage heat control provides an accurate and dependable heat control for the dryer. As selector knob is moved from "hot" to "cold", or to any intermediate stage, damper below steam heating unit is rotated in stages from hot to cold, providing varying degrees of warm, or cool air, according to setting. The operator can move selector knob to a cold position to cool a load, and then quickly return to the setting at which the load was dried. The temperature at this setting, for repeat operation, will be exactly the same as it was originally.

The Cissell 36CD30 drycleaning dryer comes equipped with an inclined self-cleaning lint screen. In this system, lint accumulates on the underside of the screen until a blanket approximately 1/4" thick is formed. This blanket of lint will fall from the screen to the bottom of the dryer cabinet, and should be removed daily, or as required to prevent an over accumulation.

As an alternate, Cissell offers a large full width lint drawer. Lint is collected within the drawer on a large perforated metal area which permits full air flow while reducing the lint problem common to all clothes drying.

A Two-Way Fire Extinguisher injects steam instantly into basket and lint trap ... cuts off electric current to fan and basket motor by melting a fusible link; or, by operation of an explosion responsive mechanism.

The Static Steam Spray, operated by a hand valve, injects line steam into dryer during cycle for faster humidification. Also dissipates static charges thus reducing lint attraction and chance of fire from static sparking.

It is preferable to use the static steam spray at the start of the drying run when the volatile vapor is at the highest concentration point. The moisture from the steam reduces the fire hazard and static electricity, permitting a more rapid removal of lint from the garments.

SPECIFICATIONS

FLOOR SPACE:	
Width	38"
Depth-60 cycle	50½"
50 cycle	50½"
Height	75"
DOOR DIAMETER	33"
DIAMETER OPENING INTO BASKET	31-1/8"
BASKET	
Diameter	36"
Depth	30"
Volume-cubic feet	17.67
Max. Capacity-Dry Weight	50 lbs.
Max. Capacity-Wet Weight	60 lbs.
Basket RPM-Non Reversing	41
Basket RPM-Reversing	35
Reversals Per Minute	3.2
MOTORS (EXPLOSION PROOF)	
Basket	1/3 HP
Fan	1/3 HP
EXHAUST DUCT :	10" dia.
AIR DISPLACEMENT PER MINUTE	
Maximum	1250 cu. ft.
Operating Range	890-1250 cu. ft.
STEAM-OPERATING PRESSURE	60-125 pounds
Boiler HP	3.2
TRAPS-2 Required	
1 for Steam Coils - Pipe Size	3/4"
1 for Bi-Pass- Pipe Size	3/4"
STEAM SUPPLY LINE - Pipe Size	3/4"
STEAM RETURN LINE - Pipe Size	3/4"
STEAM SPRAY VALVE-	
Humidifying-Pipe Size	3/8"
STEAM FIRE EXTINGUISHING	
Valve-Pipe Size	3/4"
WEIGHTS (2-coil capacity)	
Net-60 cycle	660 lbs.
Net-50 cycle	670 lbs.
Domestic Ship. Wt. -60 cycle	740 lbs.
Domestic Ship. Wt. -50 cycle	770 lbs.
Export Ship. Wt. -60 cycle	1295 lbs.
Export Ship. Wt. -50 cycle	1325 lbs.
Export Shipping Dimensions	82"x45" x61"-
Export Crating	130.2 cu. ft.

36CD30 DRYCLEANING DRYER 2 & 4 COIL

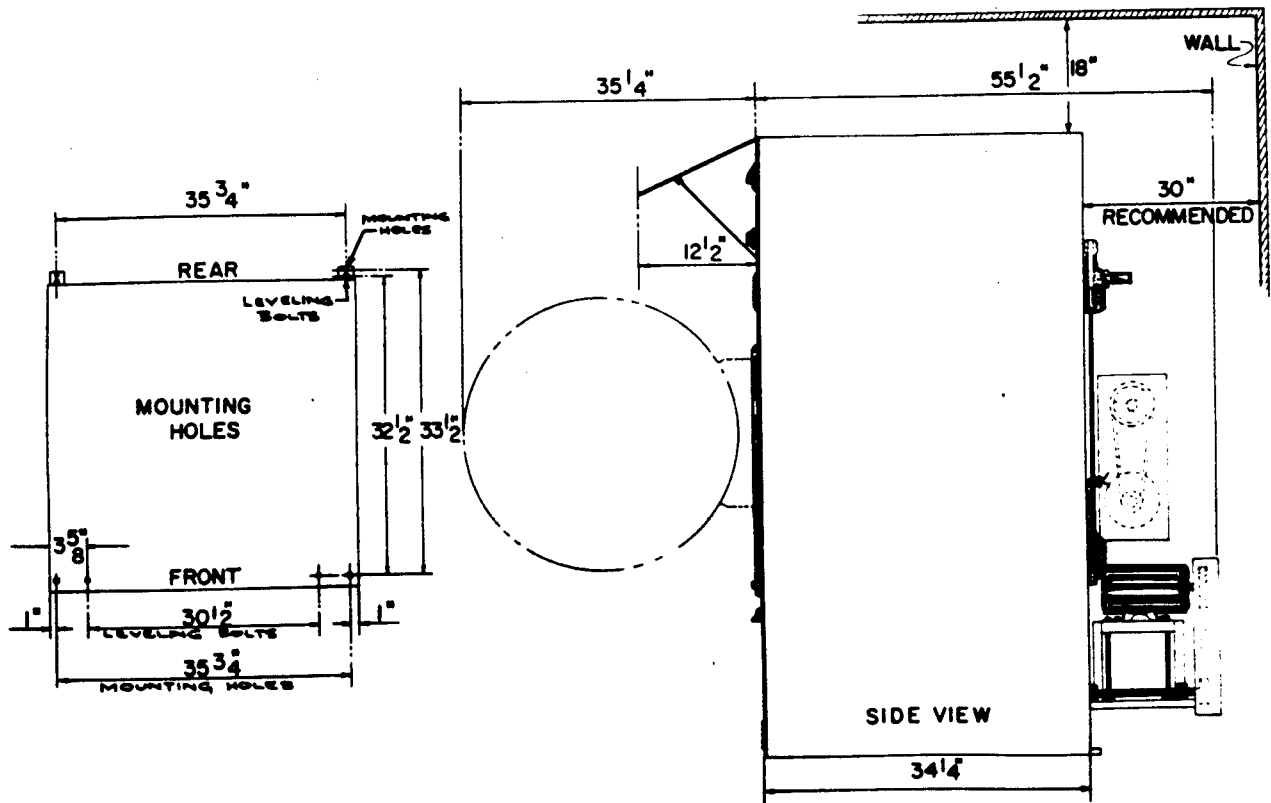
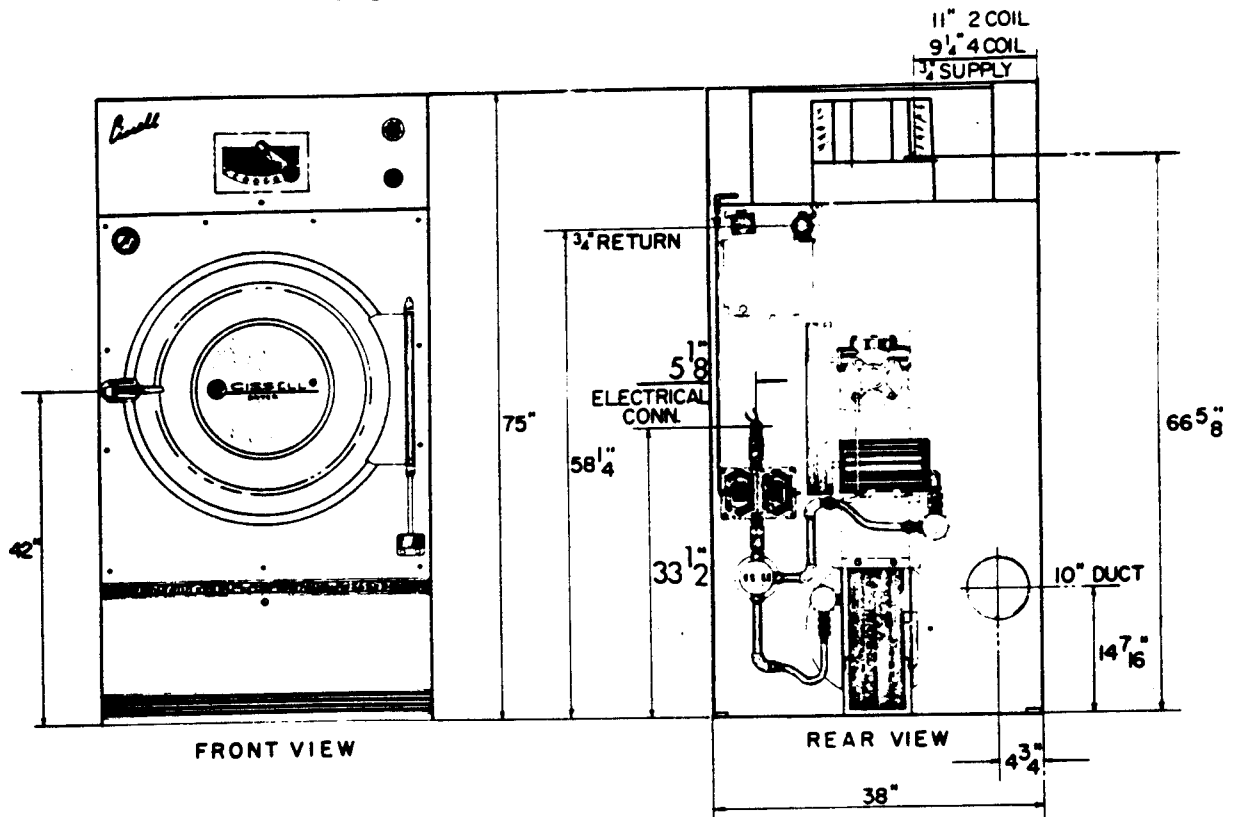

INSTALLATION

ALL DRYERS

The construction of Cissell Cabinet Dryers permits installation side by side to save space or to provide a wall arrangement. Position dryer for the least amount of exhaust piping and elbows, and allow free access to the rear of dryer for future servicing of belts, pulleys and motor.

Level and anchor dryer into position. A properly leveled dryer will assure proper trap operation and steam flow. Open basket door, remove blocking between front panel and basket; remove all tape used to secure dryer parts during shipment: **IMPORTANT:** Read all tags carefully before attempting to install dryer.

Install all duct work as per instructions on Page 6 & 7.

Install piping as per instructions on Page 8.

Make all wiring connections as per instructions on Page 9.

NOTE: On single phase reversing, three phase reversing and three phase nonreversing drycleaning dryers, an auxiliary control box is required. This control box is nonexplosion proof and must be installed in a nonhazardous area. No auxiliary control box is required for the 36BD30 nonreversing single phase dryer.

DUCTWORK INSTALLATION

Vent the 10 inch diameter exhaust, on rear of dryer, to atmosphere. Do not reduce duct size. If vent is vertical through roof, install two elbows on the discharge end forming a "U" looking down; if vent is horizontal through wall, install one elbow on the discharge end looking down, to prevent wind, rain, snow, sleet, etc., from entering duct and flowing down to dryer.

For multiple dryer installations, it is preferable to vent each dryer individually with a separate duct.

When conditions require the use of a single exhaust duct for several dryers, the piping from each dryer should enter the single duct at an angle of approximately 30°, and in the direction of the air flow. The cross sectional area of the single exhaust duct should equal the combined areas of the dryer ducts connected to it (see chart Page 7). Make all exhaust connections with the least amount of elbows to reduce air resistance to a minimum. Provide cleanout and inspection openings in the horizontal sections of the duct work.

On multiple installations employing a single exhaust duct, there should be no back draft to interfere with the normal free discharge of air from each dryer.

Before approving duct installation, place each dryer in operation; progressively open each dryer door; manually trip door switch, and see that air is drawn into the basket door opening as freely as it is when all other dryers are stopped.

Keep the exhaust ducts clean. Do not install wire mesh or screen in the discharge opening of the duct, as lint will build up and prevent proper discharge of air from dryers.

CISSELL MANUFACTURING COMPANY
 831 S. FIRST STREET • P. O. BOX 1143, LOUISVILLE, KY., U.S.A. 40201

Foreign Distributors: Address Correspondence Attention
 Export Department • Cable Code "CISSELL"
 Pacific Coast Office, 4823 W. Jefferson Blvd., Los Angeles

Ask Your Distributor

When ordering, specify part number and name.

CISSELL
DUCT INSTALLATION
28BS30 28BD30
36BS30 36BD30
DRYERS

EXHAUST DUCT INSTALLATION

NUMBER OF DRYERS IN SINGLE BATTERY—REFER TO TABLE FOR DUCT DIAMETER AT EACH DRYER OUTLET CONNECTION. FOR DIAMETER OF EXHAUST, REFER TO TABLE USING TOTAL NUMBER OF DRYERS CONNECTED THERETO. (SINGLE OR DOUBLE BATTERY.)

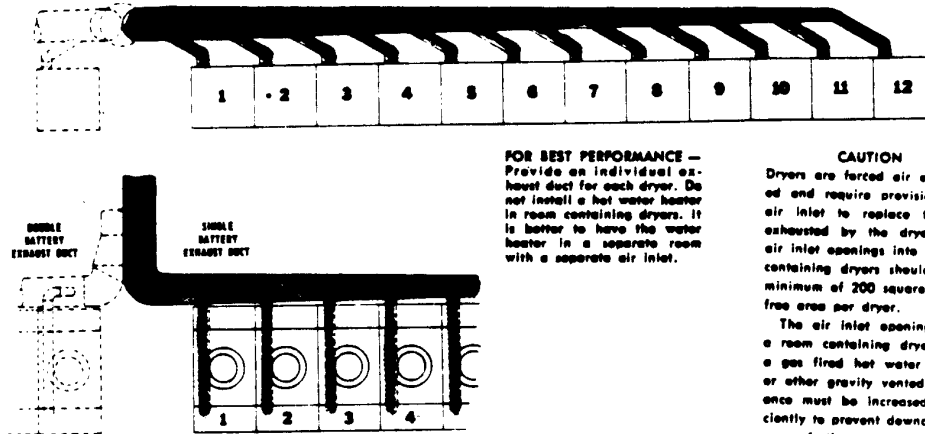

FOR BEST PERFORMANCE —
 Provide an individual exhaust duct for each dryer. Do not install a hot water heater in room containing dryers. It is better to have the water heater in a separate room with a separate air inlet.

CAUTION
 Dryers are forced air exhausted and require provisions for air inlet to replace the air exhausted by the dryer. The air inlet openings into a room containing dryers should be a minimum of 200 square inches free area per dryer.

The air inlet openings into a room containing dryers and a gas fired hot water heater or other gravity vented appliance must be increased sufficiently to prevent downdraft in any of the vents when all dryers are in operation. Do not install gravity vented appliances between dryers and air inlet openings.

Consult your local building code requirements.

NOTE: Inside of duct shall be smooth. Do not use sheet metal screws to join sections.

NO. OF DRYERS	1	2	3	4	5	6	7	8	9	10	11	12	13	14	15	16	17	18	19	20	21	22	23	24
DUCT DIAMETER	8	12	14	16	18	20	22	23	24	26	27	28	29	30	31	32	33	34	35	36	37	38	39	40

Note: Do not install wire mesh or screen in this opening, as lint will build up and prevent proper discharge of air from dryers.

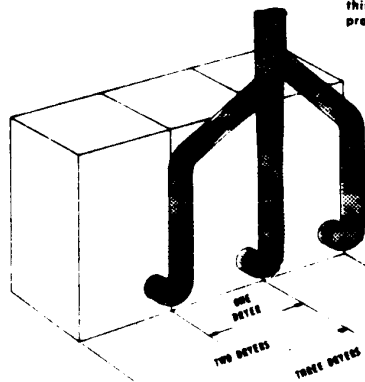

REMOVABLE STRIP OR PANEL IN FRAMING WALL TO PERMIT REMOVAL OF DRYER FROM FRAMING WALL

PARTITION OR BULKHEAD

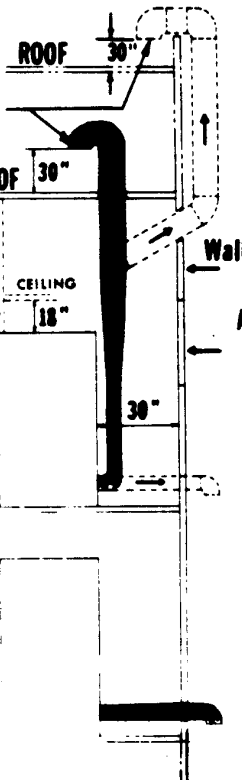

Air Inlet Must Be 4 To 6 Times The Combined Areas Of The Air Outlets

PIPING INSTALLATION

INSTRUCTIONS

IMPORTANT: INSTALL STEAM PIPING IN ACCORDANCE WITH ALL LOCAL REGULATIONS AND REQUIREMENTS

1. Set and anchor dryer in position. Machine should be level to assure proper steam circulation.
2. To prevent condensate draining from headers to dryer, piping should have a minimum riser 12" above each respective header as illustrated. Do not make steam connection to header with a horizontal or downwardly facing tee or elbow.
3. Whenever possible, horizontal runs of steam lines must drain, by gravity, to respective steam header. Water pockets, or an improperly drained steam header will provide wet steam, causing improper operation of dryer. If pockets or improper drainage cannot be eliminated install a by-pass trap to drain condensate from the low point in the steam supply header to the return.
4. In both the steam supply and steam return line, it is recommended that each have a $\frac{3}{4}$ " union and $\frac{3}{4}$ " globe valve. This will enable you to disconnect the steam connections and service the dryer while your plant is in operation.
5. Before connecting trap and check valve to dryer, open globe valve in steam supply line and allow steam to flow through dryer to flush out any dirt and scale from dryer. This will assure proper operation of trap when connected.
6. After flushing system, install bucket trap (w/built-in strainer) and check valve. For successful operation of dryer, install trap 18" below coil and as near to dryer as possible. Inspect trap carefully for inlet and outlet markings and install according to trap manufacturers instructions. If steam is gravity-returned to boiler, omit trap but install check valve in return line near dryer.
7. Install union and globe valve in return line and make final pipe connections to return header.

PIPING RECOMMENDATIONS

1. Trap each dryer individually. Always keep the trap clean and in good working condition.
2. When dryer is on the end of a line of equipment extend headers at least 4 ft. beyond dryer. Install globe valve, union, check valve and by-pass trap at end of line. If gravity return to boiler, omit trap.
3. Insulate steam supply and return line for safety of operator and safety while servicing dryer.
4. Keep dryer in good working condition. Repair or replace any worn or defective parts.

ELECTRICAL CONNECTIONS

MAKE SURE SEALING COMPOUND HAS BEEN
INSTALLED AS PER INSTRUCTIONS ON PAGE 10

DRYERS MUST BE ELECTRICALLY GROUNDED by a separate #14 or larger wire from the grounding terminal within the service connection box to a cold water pipe; or through the grounded neutral of a 3-wire system properly grounded and connected to the grounding terminal. In all cases, the grounding method must comply with local electrical code requirements.

Do not change wiring without consulting factory or you may void your guarantee. Do not connect the dryer to any voltage or current other than that specified on the tags placed on the power leads of the dryer.

All wiring should be done by a competent electrician. A fused disconnect power switch must be installed in the power connections to each dryer and as near the dryer as possible. It must be accessible for immediate operation, when required. If the power disconnect switch is mounted within the hazardous area, it must be an approved explosion proof type; when installed outside the hazardous area, the disconnect switch may be a conventional, approved, non-explosion proof type. NOTE: IF DRYER HAS AUXILIARY CONTROL BOX, IT MUST BE MOUNTED IN A NON-HAZARDOUS AREA AS PER LOCAL CODE REQUIREMENTS.

Upon completion of wiring, check dryer operation and see that all parts operate properly. When viewed from the front of the dryer, the basket should rotate counter-clockwise; the fan should rotate clockwise. To check fan rotation, remove lint screen and look into fan through the lint door opening. Additional information, see page 26.

DRYING PROCEDURE

Cissell recommends that test loads of old, discarded clothing be run so that operator may familiarize himself with operation and approximate drying time required.

The drying time varies according to the degree of extraction, size of load, type of fabric and moisture content. When a normal load is completely extracted, the drying time will be approximately 20 minutes.

Normally, "non-critical" garments such as cottons and linens are dried at high temperatures; "critical" garments, such as wools and silks are dried at lower temperatures.

For estimating purposes, the productive capacity of the 36"x30" drycleaning dryer is approximately 65 to 85 pounds per hour.

WHEN DRYING IN A CISSELL 36"BD30" DRYCLEANING DRYER WITH BELL TIME ALARM FOLLOW THE STEPS LISTED BELOW:

1. Load dryer basket and close door.
2. Set Bell Timer to required time.
3. Set 8- Stage Heat Control (located on upper panel of dryer) to desired stage of heat.
3. Turn Main Control Knob "ON".

INSTRUCTIONS FOR SEALING CONDUIT HUBS

The following instructions must be followed to seal conduit hubs, therefore, assuring safety in the explosion proof controls.

NOTE: Sealing Compound and fiber is furnished for the two vertical Seals, one above the switch box and the other below, on the rear of 36x30 Drycleaning Dryer. One Seal below Switch Box, on the rear of 44B42 Drycleaning Dryer.

No Sealing Condulets are required for the electric Motors for they have "built in" seals.

The Junction Box does not have to be sealed

Spread wires apart and pack fiber between and around the wires in each conduit hub. It is important that the wires be permanently separated from each other, so that the sealing compound will surround each wire.

CAUTION: Do not leave shreds of fiber clinging to side walls of sealing chamber or to the conductors. Such shreds when imbedded in the compound may form leakage channels.

Use a clean mixing vessel to mix two parts sealing compound to one part clean cold water. Slight deviation in these proportions will not affect the result.

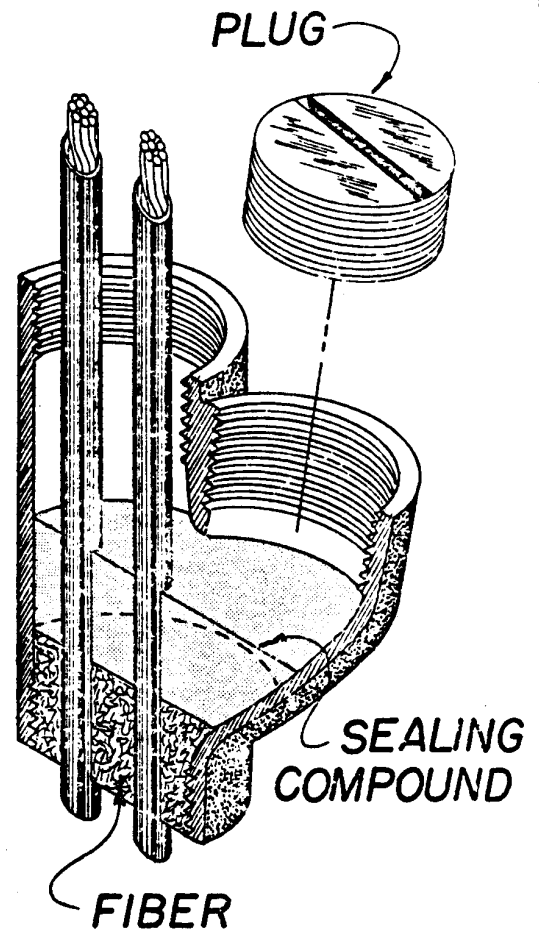

MAINTENANCE

1. **CLEAN LINT TRAP DAILY:** Remove lint before starting day's operation. A clean lint trap will increase the efficiency of the dryer, as the moisture laden air will be exhausted to the atmosphere more quickly.
2. **KEEP BASKET AND SWEEP SHEETS CLEAN:** Clean periodically and clean as often as required. The basket and sweep sheets within the dryer are easily accessible for cleaning by removing the front panel of the dryer.
3. **GEAR REDUCER:** Maintain oil level in gear reducer 1/2 depth of oil cup. Use Cissell Transmission Oil. (See attached Cissell Gear Reducer sheet).
4. **PULLEYS AND BELTS:** Keep belts clean. Oil and dirt will shorten the useful life of a belt. Never allow a belt to run against the belt guard. Check belts periodically for alignment. Pulley shafts must be parallel and the grooves must be in alignment. Check and re-tighten pulley set screws periodically. Check belt tension periodically. Lower motor to increase tension by adjusting the nuts fastening the motor plate to the 5/16" rod connected to the gear reducer.
5. **ELECTRIC MOTORS:** Keep motors clean and dry.
Motors having BALL BEARINGS are packed with sufficient grease for approximately five years of operation under normal conditions. After five years, the bearings and housing should be cleaned thoroughly. Repack each bearing and the cavity back of the bearing one-third full with G. E. Ball Bearing grease.
6. Motors having wool packed SLEEVE BEARINGS are oiled at the factory for one years normal operation. After one years normal operation, add annually 1/2 teaspoon electric motor oil or S.A.E. #10 to each bearing. For 24 hours per day operation, add one teaspoon of oil annually.

If motors overheat, check voltage and wiring. Low voltage, inadequate wiring and loose connections are the principle cause of motor failure.

ADJUSTABLE LEVELING BOLTS: One at each corner, front and rear permits accurate alignment of dryer.

TO ADJUST: Block corner of dryer up off floor. Loosen hex nut. With wrench, turn bolt clockwise to raise dryer; counter-clockwise to lower. Rear bolts are on outside rear of dryer. Hex nuts for front bolts are inside lint trap.

7. **PILLOW BLOCK BEARINGS:** Monthly apply High Temperature (300°F) grease to the two bearing (item 5 page 21) on the fan motor hack shaft with a grease gun. Do not over load as it will shorten life of bearing.
8. **STEAM HEATING UNITS:** Keep steam coils clean. Check periodically and clean as often as required. Remove lint and dirt accumulation from coil fins periodically as dirty lint laden coil fins decrease the efficiency of steam-heated dryer.

VENT: IMPORTANT

Remove this screw before placing machine in operation.

OIL FILL

Remove worm gear cover, pour oil in gear reducer to oil level (one-half depth of oil cup).

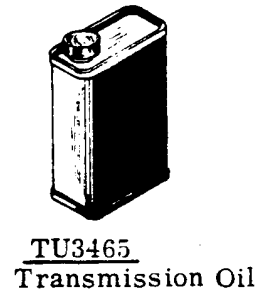
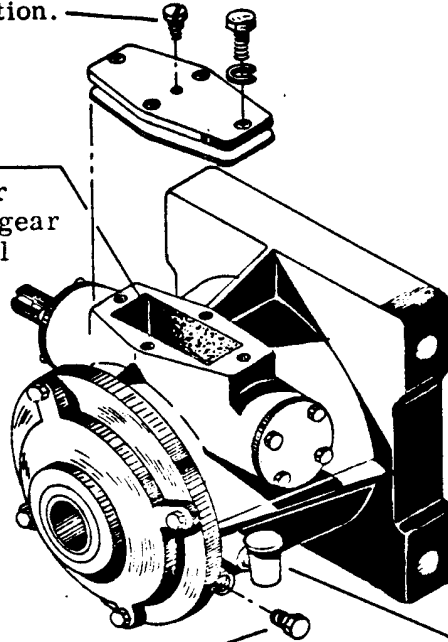

DRAIN PLUG

OIL LEVEL CUP

Oil level one-half depth of cup. Do not overflow. Remove cork from oil level cup.

BEFORE PLACING THE DRYER IN OPERATION, Remove small screw from vent in oil fill atop each Gear Reducer case. Remove the cork from the oil level inspection cup. If the oil level is correct, the oil level inspection cup will be half filled with oil. If not, add oil. Oil may be added to the Gear Reducer by removing the worm gear cover in the top rear of the Gear Reducer case. Do not operate a Gear Reducer unless the drain plug is tight, and the vent screw removed.

If it is necessary to return a Gear Reducer to the factory, either replace the small screw in the vent and plug the oil level inspection cup with a cork, or drain all oil from the reducer by removing the drain plug located in the bottom rear of the Gear Reducer case.

EACH GEAR REDUCER is filled with 1 pint of Cissell TU-3465 transmission oil before leaving the factory. Change oil once every 6 months.

THE LARGE TIMKEN BEARINGS, which support the worm gear and basket load, must operate in a preloaded condition, that is the worm gear must not have end play. The Gear Reducer is assembled at the factory to provide a 5-8 inch lb. pre-load on these bearings.

THE SMALL TIMKEN BEARINGS, which carry the worm must operate in a preloaded condition, that is, the worm must not have end play. The Gear Reducer is assembled at the factory to provide a 2-4 inch lb. preload on these bearings.

INSTRUCTIONS FOR ALIGNING BASKET ON CISSELL 50 LB. DRYER - DOUBLE MOTOR

1. Loosen the 4 gear reducer mounting bolts (1, 2, 3 & 4) on rear of dryer, and 2 adjusting bolts #5, on gear reducer housing. (Fig. 3).
2. Place one "A" and two "B" diameter pins inside the drying compartment between the rim of the basket opening and the rim of the door opening in the positions shown in Figure 1 and Figure 2. Check the two "B" pins for equal clearance.
3. With the pins in position, tighten the two No. 5 bolts until flush against back of dryer. Retighten gear reducer mounting bolts in the numerical order indicated in Figure 3. Tighten lock nuts No. 6 to secure bolts No. 5 in position. Then remove pins.
4. Check the space between basket and door opening at "A" pin and "B" pin positions (Figure 2). If the gap is not approximately the same on both sides, repeat steps 1, 2 & 3.

NOTE: Use short sections of round steel rod for pins or drill bits may be used in place of round rod.

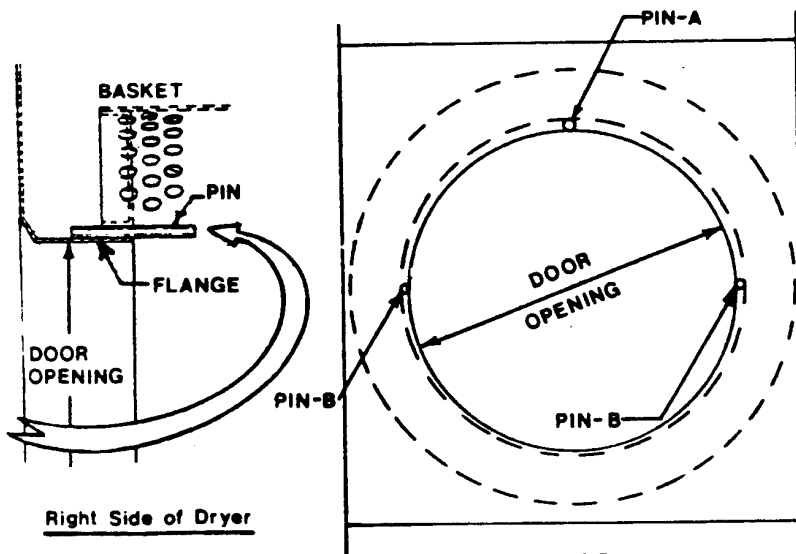

Fig. 1
Right Side of Dryer

Fig. 2
Front of Dryer
PIN-A-1/2 DIA.
PIN-B-5/16 DIA.

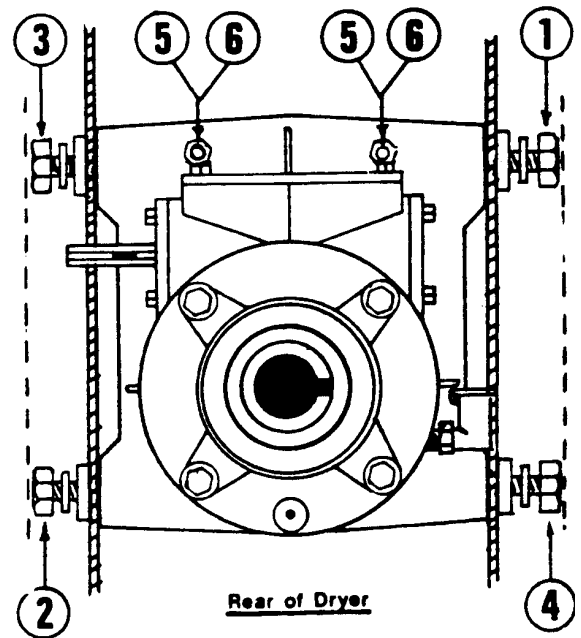

Fig. 3
Rear of Dryer

NOTE: On original equipment, the Cissell Gear Reducer is equipped with a Garlock Shaft Seal. If this seal requires replacement, it cannot be replaced with the same type of seal since the original seal would have seated in on the shaft. It must be replaced with a TU2166.

REMOVAL AND INSTALLATION of SEALS on GEAR REDUCER OF CISSELL[®] DRYERS

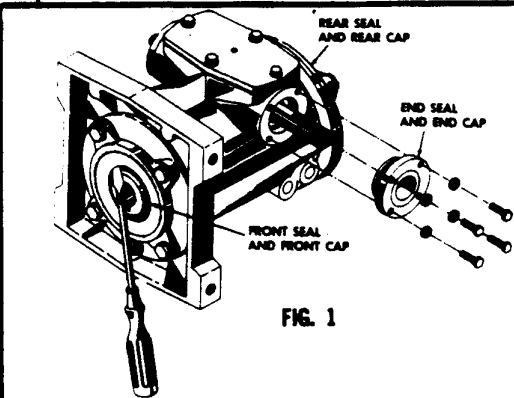

FIG. 1

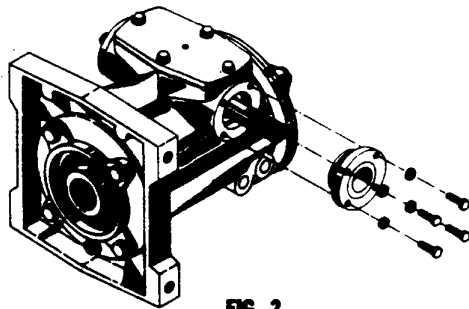

FIG. 2



FIG. 3

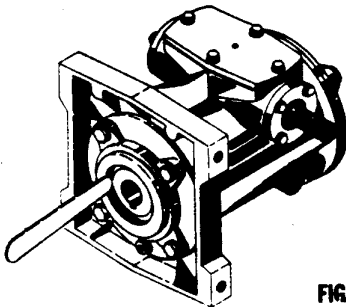

FIG. 4

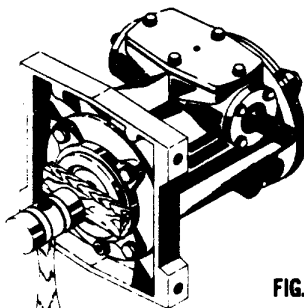

FIG. 5

CAUTION

Drain oil before removing seals; replace with NEW oil after installing new seals (See Cissell Gear Reducer Sheet).

Remove Gear Reducer from rear of dryer before removing seals.

TO REMOVE EXISTING FRONT AND REAR SEALS from front and rear caps on Gear Reducer (Fig. 1):

Slip end of screwdriver under seal (front seal illustrated); using end of Gear Shaft as a fulcrum, force seal out. Repeat operation at several different places until seals are removed from gear shaft.

TO REMOVE EXISTING END SEAL and END CAP from Gear Reducer (Fig. 1):

Remove four cap screws and slip end cap and seal from worm gear. Tap seal out of cap from inside.

Clean inside of front, rear, and end caps. Spread permatex evenly over area to receive seal. Clean outside end of large and small gear shafts. Spread vasoline evenly over area to receive seal, (Fig. 2).

Spread permatex evenly over outside rim area, (Fig. 3) of seal. Spread vasoline evenly over inside rim area of seal.

TO INSTALL NEW FRONT AND REAR SEALS:

Hold front (and rear) seal tightly in place over gear shaft with rubber seal in. Run edge of thin, dull instrument (such as wooden spatula, illustrated against front seal, Fig. 4) carefully around rubber wiping edge of seal and chamfer end of gear shaft so that seal is evenly installed all around gear shaft. DO NOT INJURE RUBBER WIPING EDGE.

TO INSTALL NEW END SEAL:

Slip seal in end cap. Hold cap and seal tightly in place over small shaft with rubber seal in. Run edge of wooden spatula carefully around rubber wiping edge of end seal and chamfer end of small shaft so that seal is evenly installed all around edge of shaft. DO NOT INJURE RUBBER WIPING EDGE.

AFTER SEALS ARE EVENLY INSTALLED ALL AROUND EDGES OF SHAFTS:

Place block of wood over front and rear seals and tap all around with a plastic faced mallet, (Fig. 5) until seal is flush into recess of front (or rear) cap.

Slip end seal and cap into position and tighten four bolts; then with a block of wood over end seal, gently tap with plastic faced mallet, until seal is flush into recess of end cap.

REINSTALL GEAR REDUCER ON REAR OF DRYER

IMPORTANT

While the sealing element or packing ring in a seal is not fragile, care must be taken to prevent damage to the wiping edge during mounting. Do not apply pressure to, nor hammer directly on, the sealing ring or spring; make sure that all mounting tools contact only the metal case of the seal.

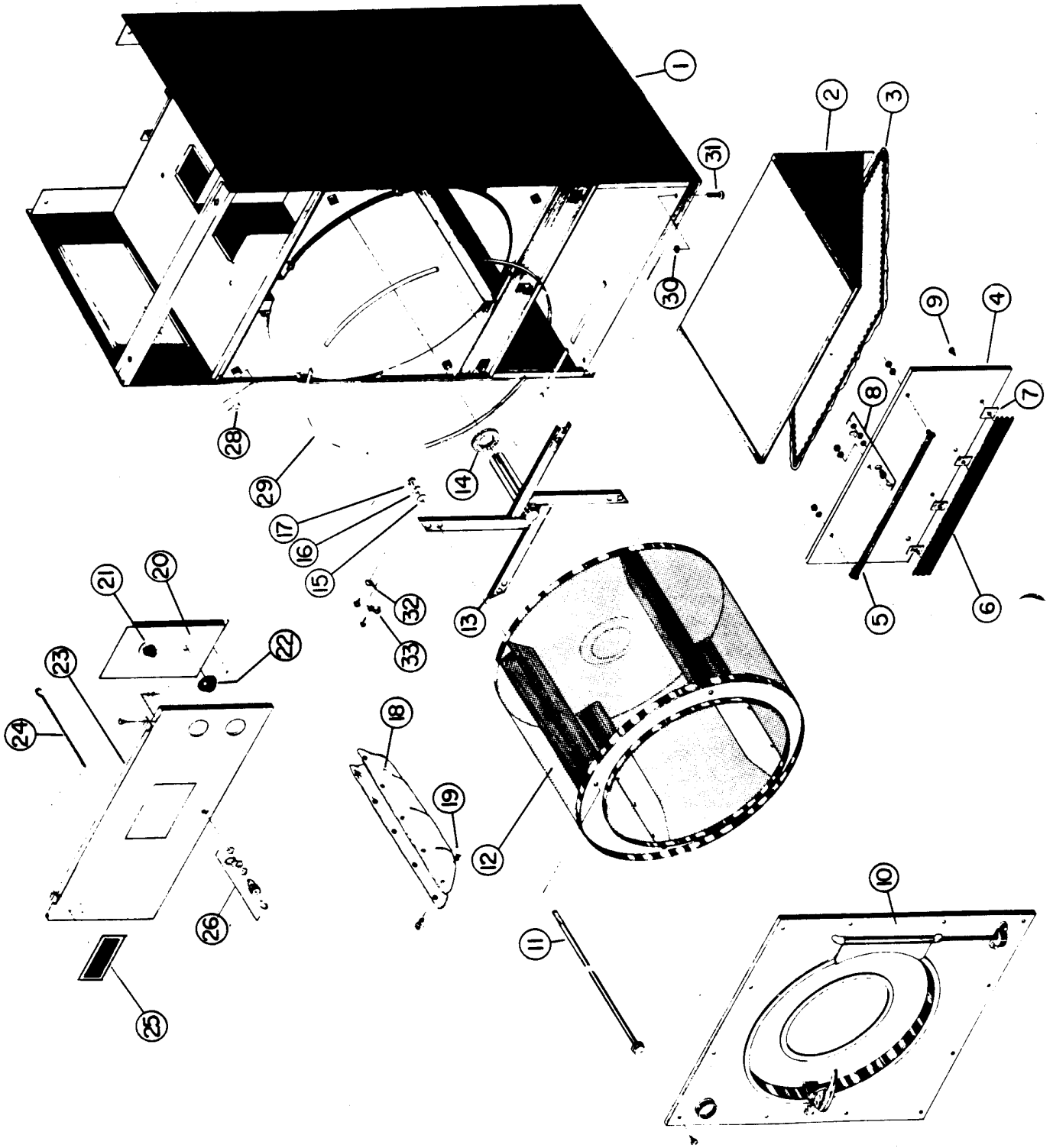

Ref. No.	Part No.	Description
1	TU6225	Jacket
<u>TU6447 SELF-CLEANING LINT TRAP ASS'Y. consists of Ref. 2 & 3</u>		
2	TU8368	Lint Trap Frame W/A
3	TU5261	Self Cleaning Lint Screen
<u>TU5808 LINT TRAP DOOR ASS'Y. consists of Ref. No. 4-9</u>		
4	TU5566	Lint Door Welded Ass'y.
5	TU7473	Handle
6	TU2385	Trim
7	TU2710	Trim Holder
8	TU4822	Lock
	TU2844	Key
9	F557	#10-24x3/8" Rd. Hd. Mach. Scw
10	TU6009	Front Panel & Door Ass'y. See Separate Page
<u>TU7033 BASKET COMPLETE consists of Ref. No. 11-17</u>		
11	TU2313	Tie Rod
12	TU7034	Basket Weldment
13	K108	Spider Assembly
14	TU108	Felt Seal
15	TU2831	1/2" Extra Heavy Lock Washer
16	TU2883	1/2" Cut Washer
17	TU2882	1/2"-20x3/4" Hex Nut
18	TU6347	Rib Cover
19	TU2792	Clip
<u>TU6227 CONTROL PANEL ASSEMBLY consists of Ref. No. 20-21</u> See Separate Page		
20	TU6126	Mounting Plate
21	T308	Timer
22	TU3322	ON-OFF Knob
<u>TU8272 TOP FRONT COVER PANEL ASS'Y. consists of Ref. No. 23-27</u>		
23	TU8271	Access Door W/A
24	TU5739	Door Support Arm
25	TU8013	"Cissell" Nameplate
26	TU4822	Lock
	TU2844	Key
27	TU3137	Speed Nut
28	TU5137	#10 Speed Nut
29	TU5876	Set of 8 Sweep Sheet Gasket
30	TU4937	3/8"-16 Jam Nut
31	TU3211	3/8"-16x2-1/2" Leveling Bolt
32	TU5337	Thermometer Bulb Support
33	F646	Thermometer Clamp

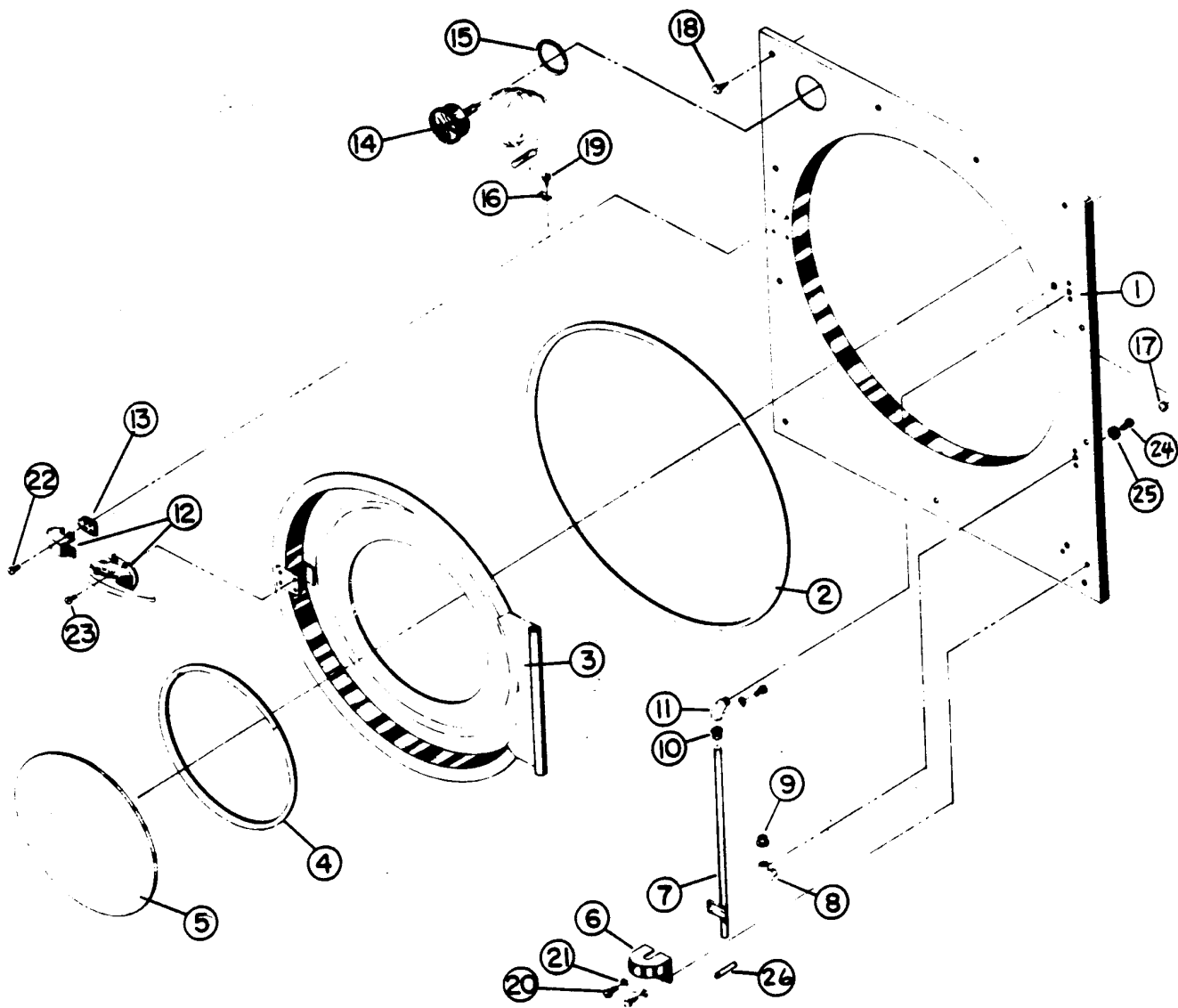

Ref. No.	Part No.	Description	Ref. No.	Part No.	Description
1	TU6065	Front Panel Ass'y.	13	TU5503	Latch Spacer
2	TU5288	Basket Door Ass'y.	14	TU3593	Thermometer
3	TU5500	Door Panel Welded Ass'y.	15	TU2641	Thermometer Gasket
4	TU1692	Door Glass Gasket	16	F645	Bulb Support Clamp
5	TU5287	Door Glass	17	TU6259	13/32" Plug Button
6	TU6046	Switch Lever Housing	18	TU2878	#10x5/8" S. M. S.
7	TU2470	Door Switch Rd Ass'y.	19	M263	#8-3/8" S. M. S.
8	TU2471	Lower Hinge Post	20	TU2836	5/16"-18x1/2" Hex Hd. Scw.
9	TU2497	Lower Delron Bearing	21	TU3212	5/16" Internal Tooth Lock-washer
10	PIF172	Upper Delron Bearing	22	TU2687	#8 Phillips Scw. & Washer
11	TU2236	Upper Hinge Post	23	TU2686	#8-32x3/8" Phillips Hd. Scw.
12	TU2319	Door Latch W/Keeper	24	TU2820	#10x1/2" Hex. Hd. S. M. S.
			25	TU4820	#10 Cut Washer
			26	OP357	1/8"x1" Roll Pin

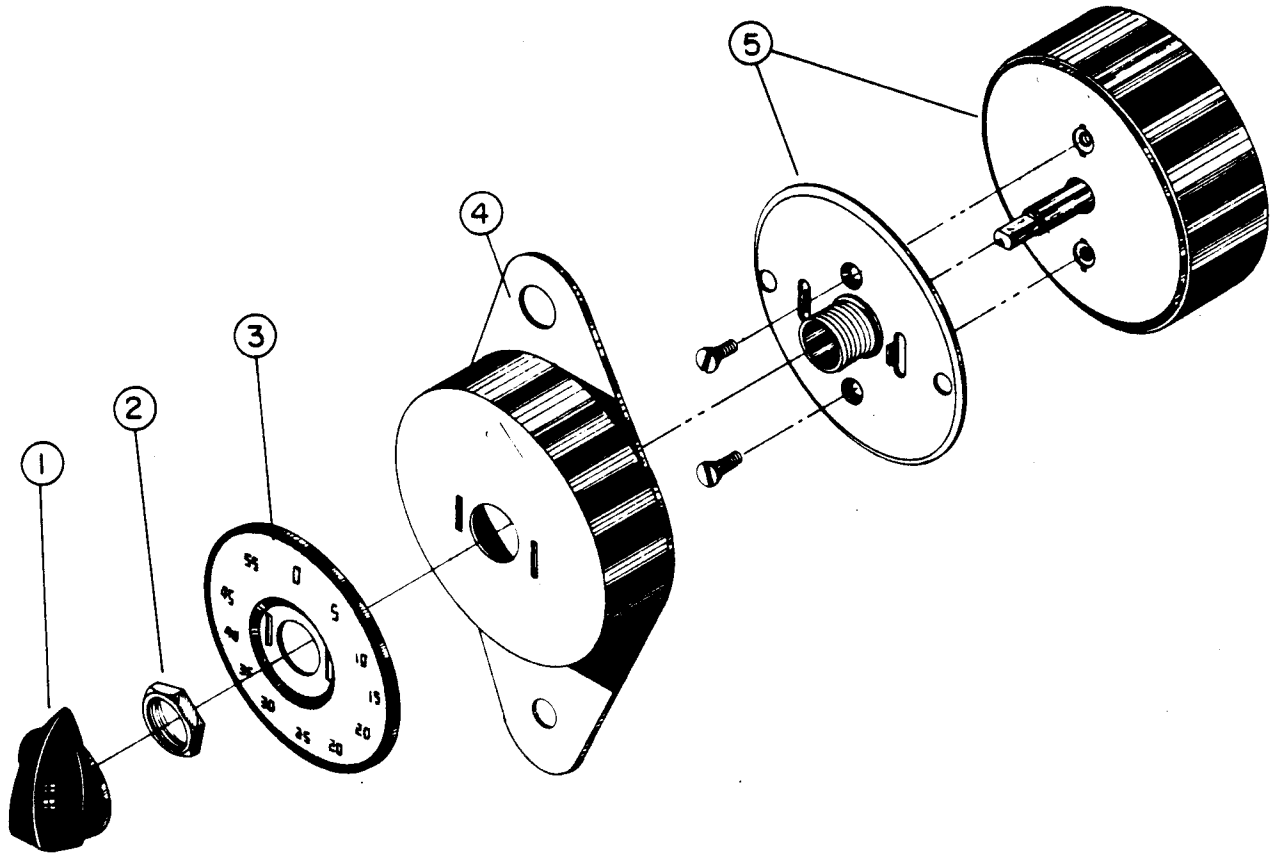

Ref. No.	Part No.	Description
1.	T148	Knob
2.	TU3805	15/32-32 Hex Lock Nut
3.	TU5000	Dial (56 Min.)
4.	T204	'C' Adapter
5.	T308	56 Min. Timer

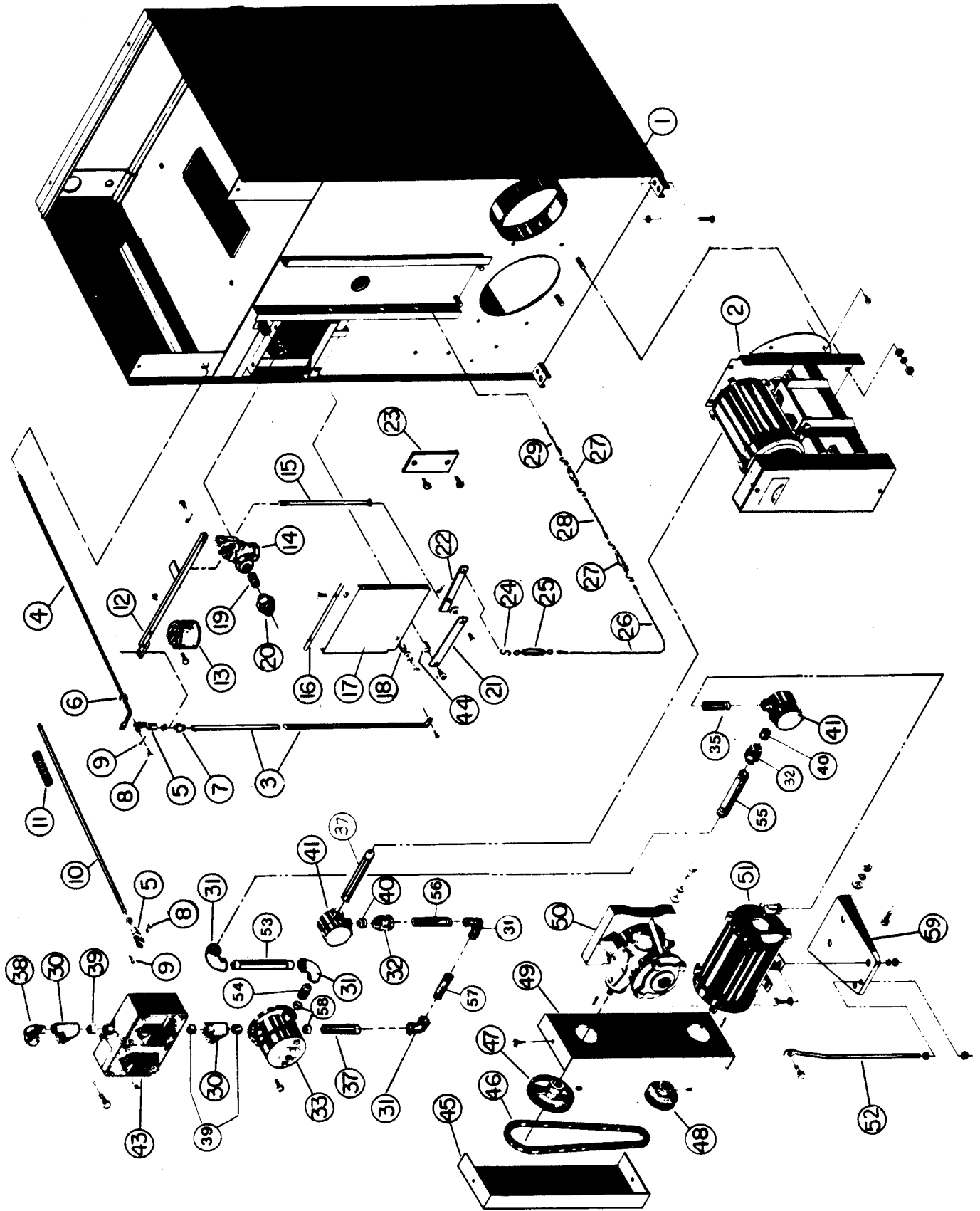

REAR VIEW OF DRYER

<u>Ref. No.</u>	<u>Part No.</u>	<u>Description</u>	<u>Ref. No.</u>	<u>Part No.</u>	<u>Description</u>
1	TU6225	Jacket	37	TU6248	½"x6" Conduit Nipple(2)
2	TU6226	Fan Assembly	38	TU3382	¾" Conduit Steel Ell
		See Separate Page	39	TU6245	¾" Conduit All Thread Nipple (3)
3	TU6135	Horizontal Switch Rod			½" Conduit All Thread Nipple (2)
4	TU3349	Vertical Switch Rod	40	TU6246	½" Condulet (2)
5	P39	Yoke	41	TU3373	See Page 18
6	F215	Set Collar	43		Hex Linkage Spacer
7	P33	Retainer	44	TU5781	Belt Guard Cover
8	SF48	Clevis Pin	45	TU3857	V-Belt (4L-380)
9	V2	Cotter Pin	46	TU2317	Gear Sheave
10	TU6148	Door Switch Rod	47	TU2323	AK51-5/8, 60 Cy.
11	TU4631	Switch Rod Spring			Gear Sheave
12	TU6117	Weight Support Arm		TU2211	AK46-5/8, 50 Cy.
13	TU5770	Weight			Rev. Gear Sheave
14	TU3363	¾" Quick Opening Valve		TU6722	AK51H-5/8, 60 Cy.
15	TU6011	Push Rod			Rev. Gear Sheave
16	TU5779	Hinge Pin		510101040	AK46H-5/8, 50 Cy.
17	TU6096	Explosion Hatch Plate			Motor Sheave
18	TU6151	Push Rod Linkage Support	48	F1034	AK34-5/8, 60 & 50 Cy.
19	TU4608	¾"x2" Pipe Nipple			Rev. Motor Sheave
20	TU4600	¾" Pipe Union		TU7334	AK34H-5/8, 60 Cy.
21	TU5774	Push Rod Linkage			Rev. Motor Sheave
22	TU5775	Push Rod Support Bar		TU7470	AK39H-5/8, 50 Cy.
23	TU6362	Air Switch Hole Cover			Belt Guard Mount
24	J17	"S" Hook	49	TU5254	Small Gear Reducer
25	TU5835	Turn Buckle	50	TU1832	Explosion Proof Motor
26	TU6254	Fuse Link Cable 34"	51	MTR144	Belt Adjusting Rod
27	TU5836	Fuse Link	52	TU8608	½"x7-¾" Conduit Nipple
28	TU5928	Fuse Link Cable 7"	53	TU9826	½" x 3" Conduit Nipple
29	TU5927	Fuse Link Cable 6"	54	TU9827	½" x 9½" Conduit Nipple
30	TU3374	¾" Condulet	55	TU9828	½" x 8½" Conduit Nipple
31	TU3383	½" 90° Elbow (4)	56	TU9829	½" x 3½" Conduit Nipple
32	TU4617	½" Explosion Proof Union	57	TU9830	¾ x ½ Pipe Bushing
33	TU3379	Guet 26 Junction Box	58	OP267	(2 Required)
35	TU6247	½" x 4" Conduit Nipple (2)	59	TU33	Motor Drive Bracket

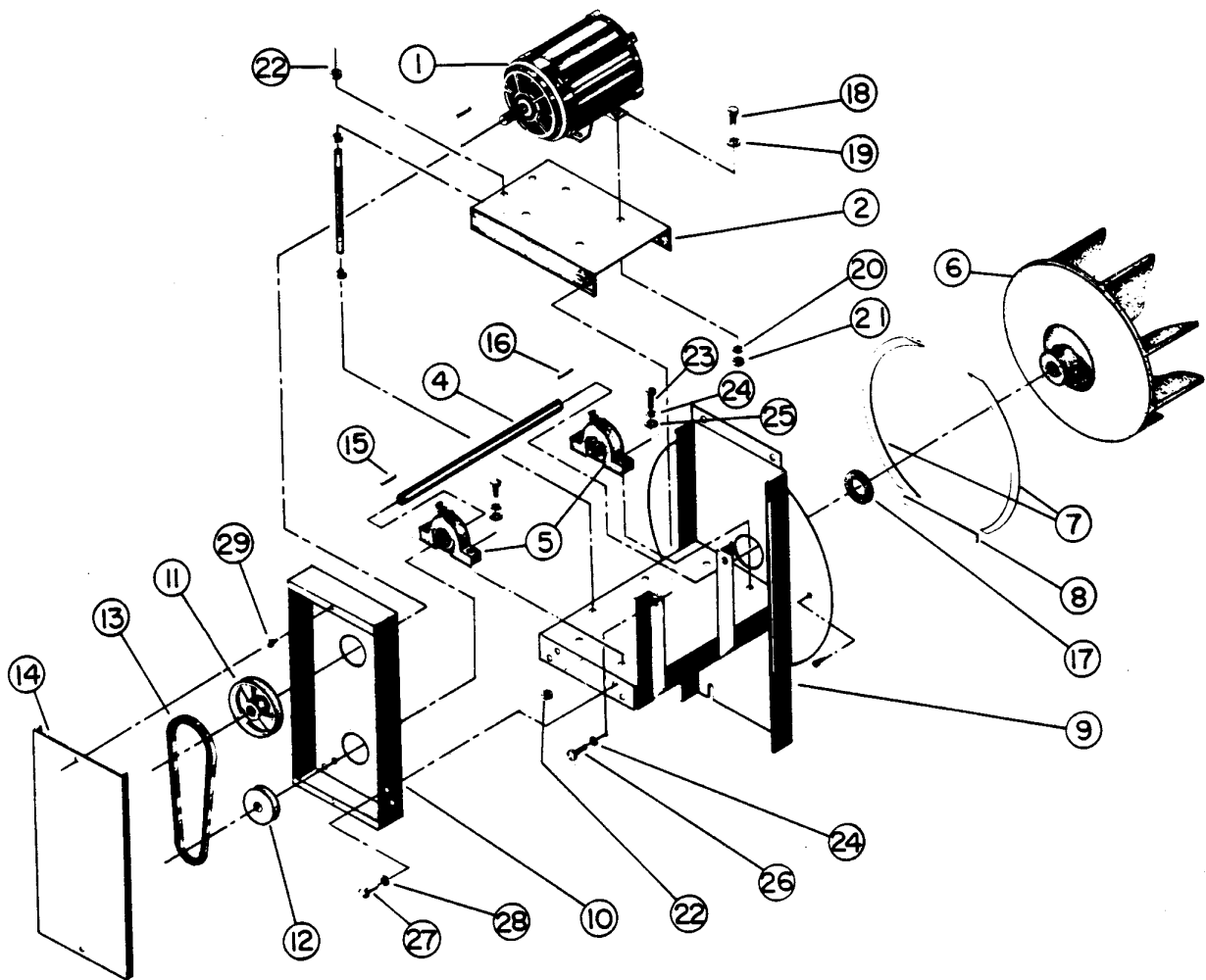

FAN COMPLETE ASSEMBLY

TU6226 - 120/240/60/1
 TU8799 - 240/50/1
 TU8800 - 208/60/3

TU8801 - 240/60/3 Rev.
 TU8802 - 380/50/3 Rev.

Ref. No.	Part No.	Description	Ref. No.	Part No.	Description
1		Specify MTR No. & Volt.	15	TU4684	Key
2	TU6718	Motor Mounting Plate	16	TU4684	Key
3	TU1950	Motor Support Rod	17	TU2476	Felt Seal
4	TU7356	Jack Shaft	18	TU3210	5/16-18x5/8 Hx. Hd. Screw
5	SB138	Pillow Block	19	VSB130	5/16 Flat Cut Washer
6	TU7354	Fan Wheel	20	TU2814	5/16 Lockwasher
7	TU2473	Side Gaskets	21	C249	5/16 Hex Nut
8	TU2474	Bottom Gasket	22	TU4787	3/8-16 Hex Nut
9	TU6714	Motor Support Weldment	23	OP380	3/8-16x1 1/2 Hx. Hd. Screw
10	TU4712	Belt Guard S.A.	24	VSB134	3/8" Lockwasher
11	TU2211	Motor Sheave (AK-46 5/8", 50/60 Cyc.)	25	IB140	3/8 Flat Cut Washer
12	TU7353	Jack Sheave (AK-39 3/4" 60 cyc.)	26	TU3124	3/8-16x3/4 Hx. Hd. Screw
	TU7352	Jack Sheave (AK-34 3/4", 50 Cyc.)	27	RC344	1/4-20x3/4 Hx. Hd. Screw
13	TU3393	"v" Belt (4L-280)	28	TU2847	1/4 Flat Cut Washer
14	TU4713	Belt Guard Cover	29	M263	#8x3/8 S.M.S.
			30	TU4934	1/4-20 Hex Nut
			31	TU3282	Set Screw
			32	F819	Set Screw

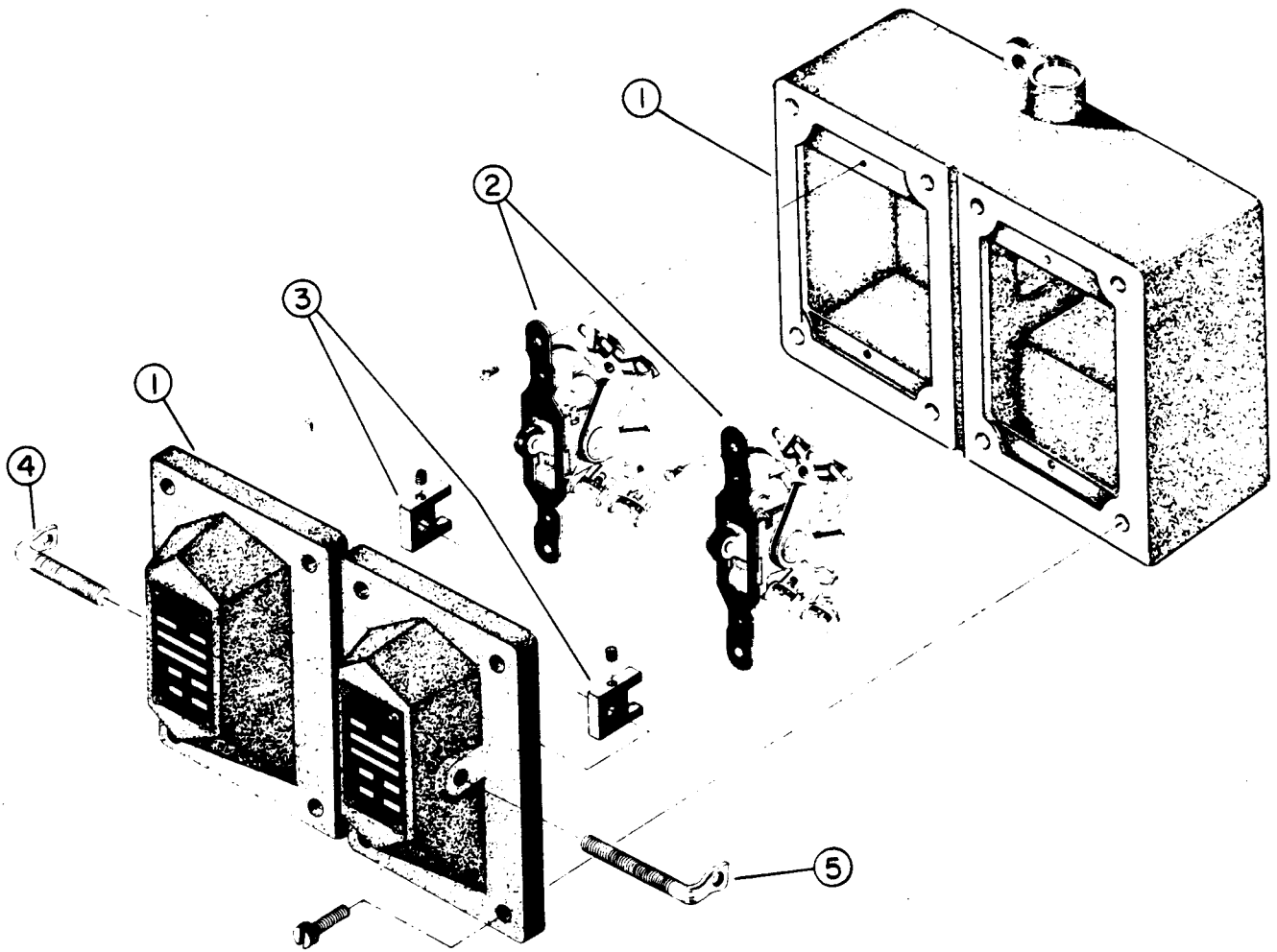

<u>Ref. No.</u>	<u>Part No.</u>	<u>Description</u>
1.	TU3381	Two Gang Switch Housing & Covers (Less Switches)
2.	TU2364	Circuit Switch
3.	TU2365	Switch Trip
4.	DTU109	Left Hand Switch Lever
5.	DTU116	Right Hand Switch Lever

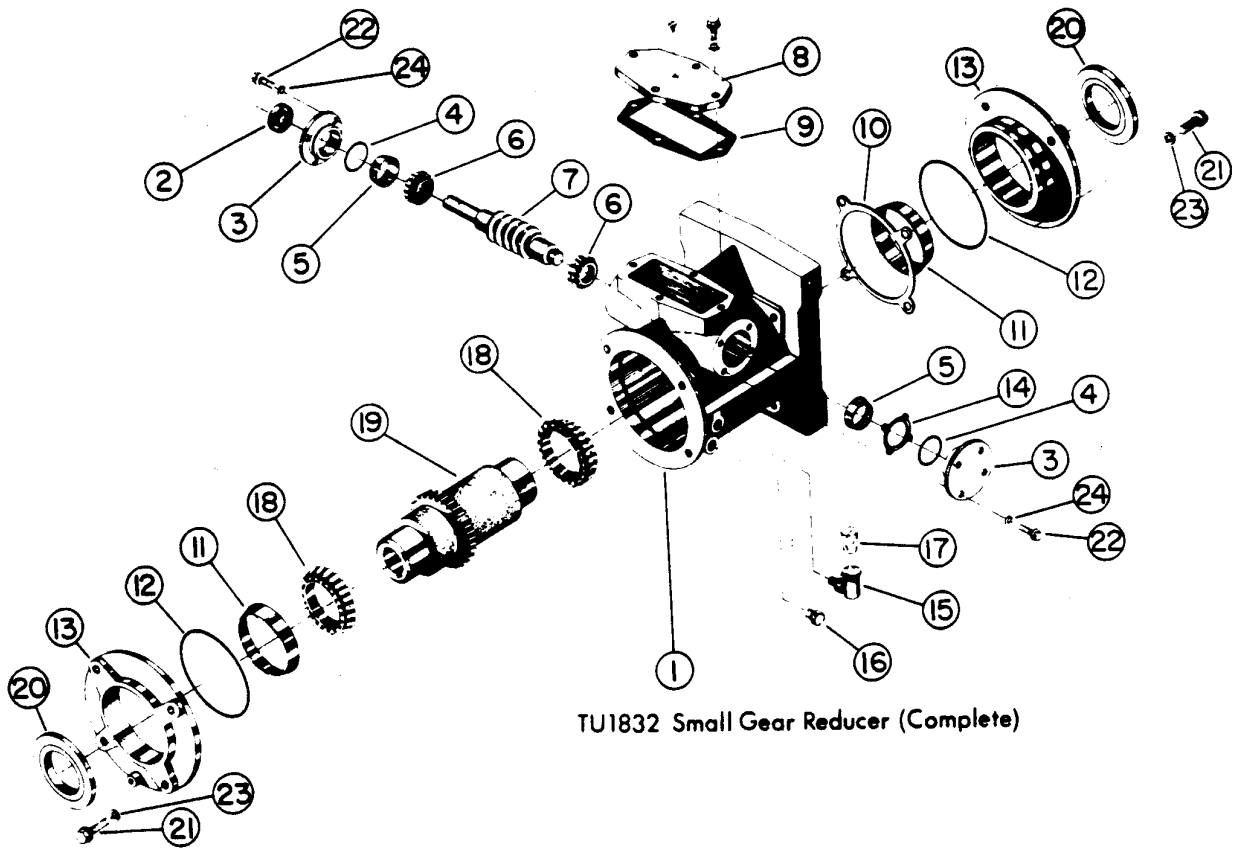

TU1832 Small Gear Reducer (Complete)

<u>Ref. No.</u>	<u>Part No.</u>	<u>Description</u>
1.	TU27	Housing
2.	TU86	Small Klozure
3.	TU25	Small Open End Cap
4.	TU88	Small 'O' Ring
5.	TU91	Small Bearing Cup
6.	TU90	Small Bearing Cone
7.	TU23	Worm
8.	TU1795	Worm Gear Cover
9.	TU1796	Worm Gear Cover Gasket
10.	TU1828	Large Shims (Set of 4) .005 & .007 2 Of Each
11.	TU93	Large Bearing Cup
12.	TU1830	Large 'O' Ring
13.	TU26	Large End Cap.
14.	TU21	Small Shims (Set of 4)
15.	TU70	Oil Cup
16.	XI57	1/4" Pipe Plug
17.	TU3199	#10 Cork
18.	TU92	Large Bearing Cone
19.	TU22	Worm Gear
20.	TU2166	Oil Seal Field Replacement
21.	TU2623	Cap Screw 3/8"-16x1-1/2"
22.	TU2839	Cap Screw 1/4"-20x7/8"
23.	TU3243	3/8" Internal Tooth Lockwasher
24.	RC349	1/4" Internal Tooth Lockwasher

TU3363 Quick Opening Valve (Complete)

<u>Ref. No.</u>	<u>Part No.</u>	<u>Description</u>
1	V5	Large Pack Nut
2	V12	Packing Glad
3	OP547	3/4"-16 Hex. Nut
4	SF15	Fork
5	TU3346	Valve Body
6	TU3364	Copper Gasket
7	TU3362	Renewable Seat
8	TU3367	Stem
9	V15	1/4"-28 Hex Nut
10	TU3368	Disc. Retainer
11	P99	Teflon Disc.
12	TU3369	Disc Holder
13	TU3365	Spring
14	P103	Copper Gasket
15	TU3366	Bonnet

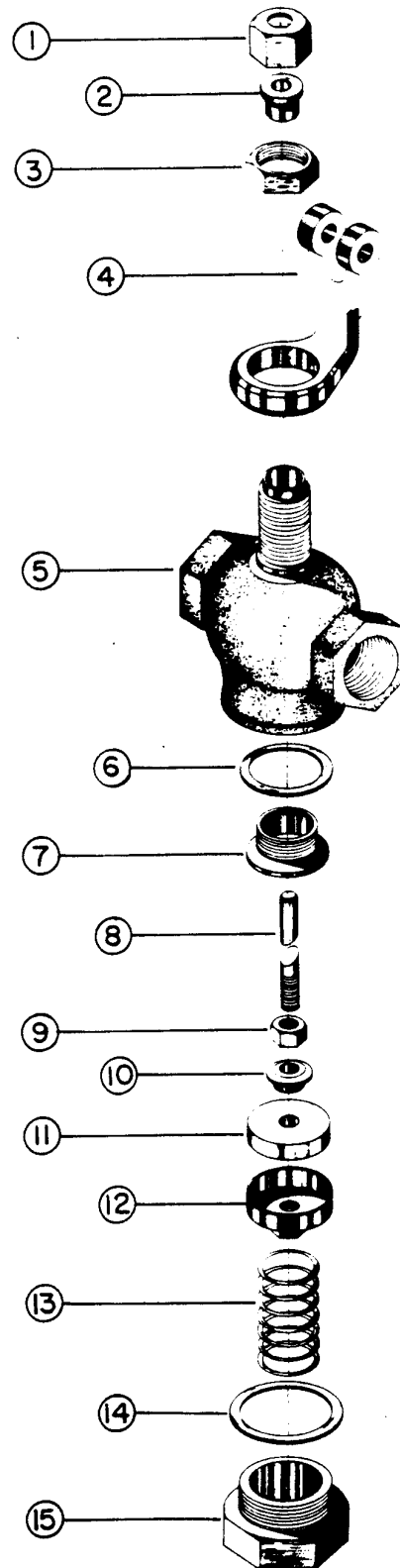

Static Steamer
Standard on all Drycleaning Dryer

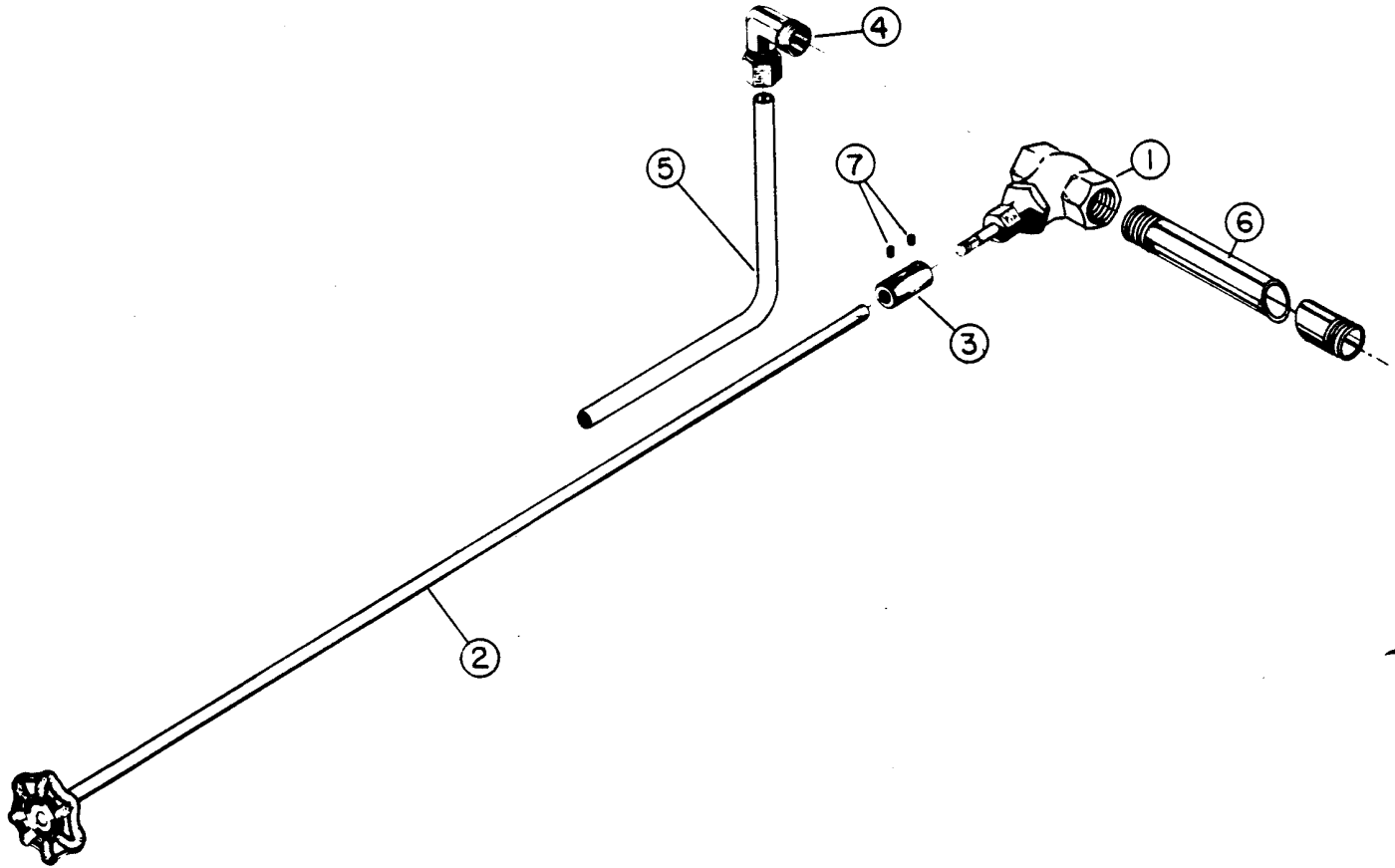

Ref. No.	Part No.	Description
1	TU8442	Valve Welded Assembly
2	TU9914	Rod & Knob Assembly
3	TU5926	Valve Rod Coupling
4	SF46	1/4"x3/8" Elbow
5	TU6050	Static Steamer Tube
6	TU6224	1/4"x5-1/4" Pipe (4 Coil)
**7	PI26	1/4"x20 Set Scw.

** Sold Only in Multiples of 6

4-COIL LAUNDRY BONNET

28-30 36-30

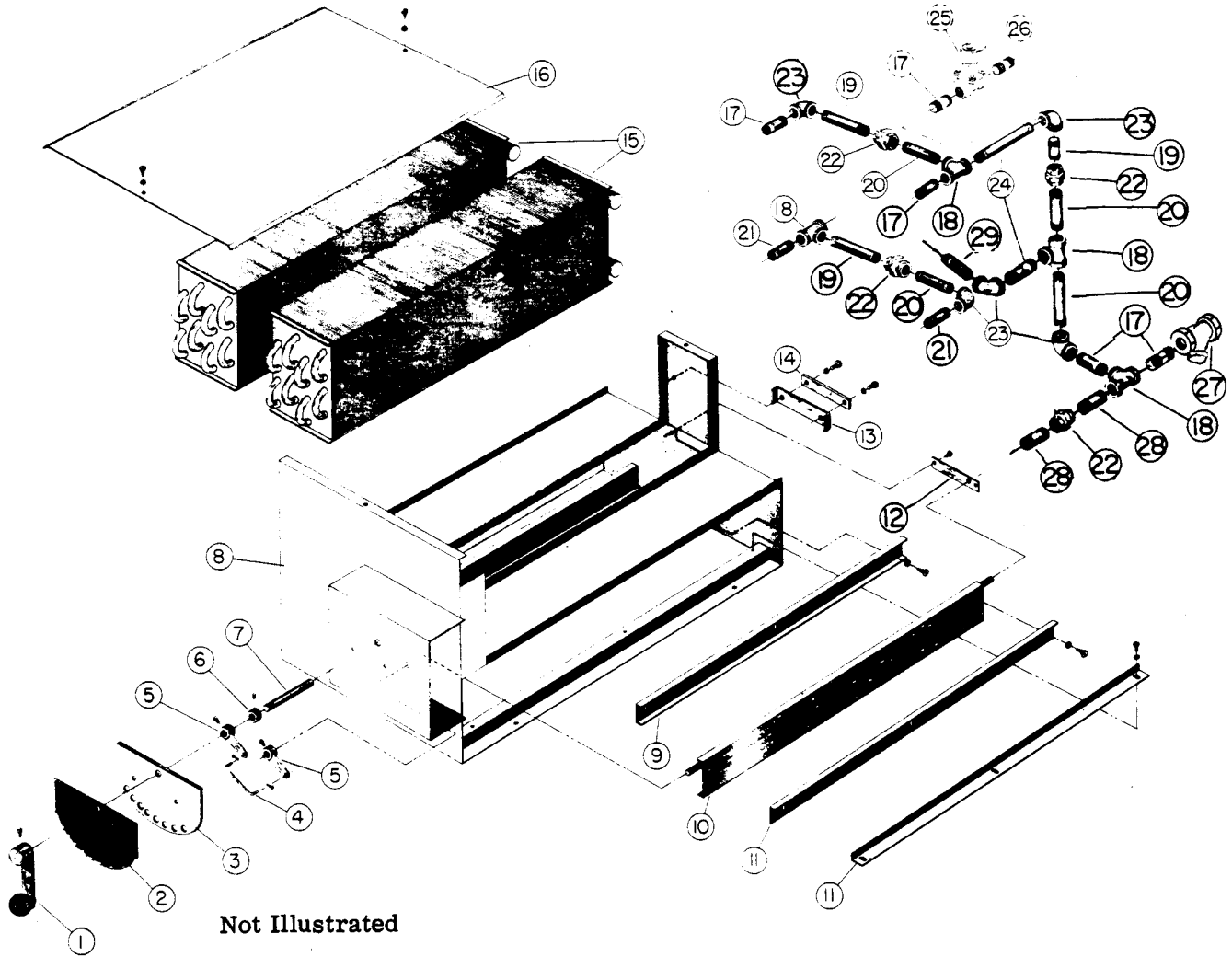

Not Illustrated

- TU5644 Lower Left Filter Guide**
- TU5676 Lower Right Filter Guide**
- TU5590 Top Filter Guide 4 Req'd.**
- TU5711 Filter 2 Req'd.**

- TU 5908 4-Coil Laundry Bonnet Complete With Solenoid Valve (120 V.)
- TU 5909 4-Coil Laundry Bonnet Complete With Solenoid Valve (240 V.)
- TU 5910 4-Coil Laundry Bonnet Complete Without Solenoid Valve

Ref. No.	Part No.	Description	Ref. No.	Part No.	Description
1	TU6053	Lever Assembly	15	TU1613	4 Coil Steam Coil
2	TU5708	Control Nameplate	16	TU5588	Top Plate
3	TU5730	Control Mounting Plate	17	TU4608	3/4" x 2" Pipe Nipple (3 req'd)
4	TU5587	Connecting Link	18	TU4597	3/4" Pipe Tee (4 req'd)
5	TU4581	Damper Arm	19	TU4601	3/4" x 3" Pipe Nipple (3 req'd)
6	F 215	Set Collar	20	TU5914	3/4" x 3 1/2" Pipe Nipple (4 req'd)
7	TU4578	Control Rod	21	TU4610	3/4" x 5" Pipe Nipple (3 req'd)
8	TU5904	Bonnet Weldment	22	TU4600	3/4" Pipe Union (4 req'd)
9	TU5574	Adjustment Channel	23	TU4605	3/4" Pipe Elbow (5 req'd)
10	TU6054	Damper Weldment	24	TU2862	3/4" x 6 1/2" Pipe Nipple (1 req'd)
11	TU5576	Adjustment Angle	25	TU5937	Solenoid Valve 120V. 50/60 cy.
12	TU5571	Damper Bearing Plate	26	TU5923	Solenoid Valve 240V. 50/60 cy.
13	TU28612	Coil Holder Plate	27	TU6204	3/4" x 2 7/8" Pipe Nipple
14	TU28611	Coil Holder Bar	28	TU2736	3/4" 'Y' Strainer
			29	TU4607	3/4" x 2 1/2" Pipe Nipple (2 req'd)
				TU6224	1/4" x 5 1/2" Pipe Nipple (1 req'd)

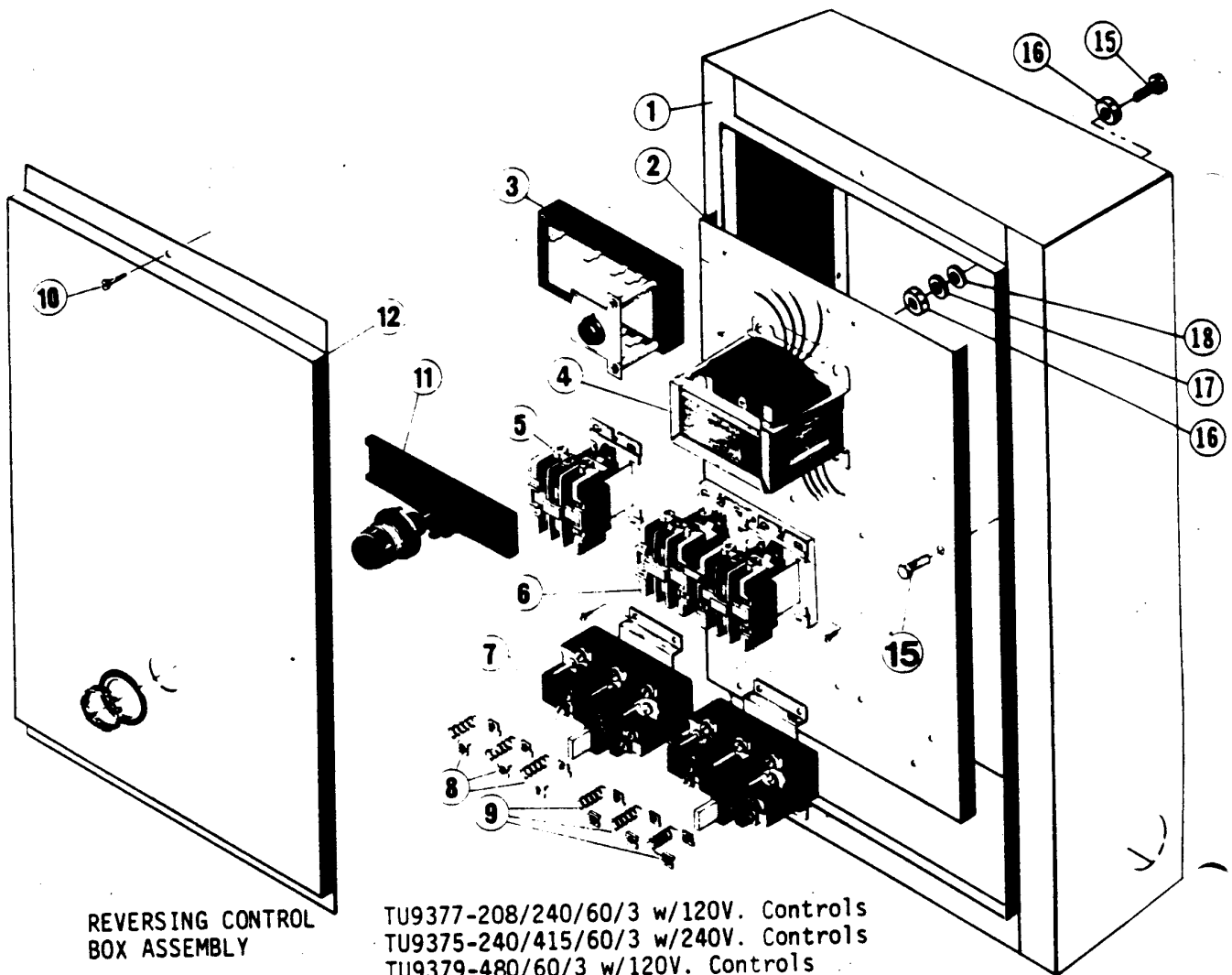

REVERSING CONTROL BOX ASSEMBLY

TU9377-208/240/60/3 w/120V. Controls
 TU9375-240/415/60/3 w/240V. Controls
 TU9379-480/60/3 w/120V. Controls
 TU9376-240/415/50/3 w/ 240V. Controls

Ref.No.	Part No.	Description
1	TU9374	Control Box Welded Assembly
2	TU6959	Mounting Panel Plate
3		Solid State Reversing Control (See next page).
4	TU4659	Transformer(for TU9375 Only)
	TU4660	Transformer(for TU9377 & TU9379 Only)
5	**TU6965	Contactor- 120V./60 Hz.
	***TU6963	Contactor- 208/240V./60 Hz.
	****TU8727	Contactor- 240V./50 Hz.
6	**TU7252	Rev. Contactor- 120V./60 Hz.
	***TU6964	Rev. Contactor- 208/240V./60 Hz.
	****TU8728	Rev. Contactor- 240V./50 Hz.
7	TU6774	Overload Unit(2 Req'd.)
8	*TU267900	Overload Heater (Fan)
9	*TU267900	Overload Heater (Basket)
10	P274	1/4"-20x3/4" Truss Head Screw
11	TU6808	Reset Button Kit
12	TU6834	Box Cover Plate
13	M263	#8x3/8" S.M.Screw
14	FB189	1/4"-20x1" Hex Bolt
15		
16	TU4934	1/2"-20 Hex Nut
17	TU2846	1/2" Cut Washer
18	TU2847	1/2" Flat Washer

* When ordering, specify number on heater, e.g. : H-25 and TU267900.

** TU7281- Contactor Coil Only.

*** TU7282- Contactor Coil Only.

**** TU8689- Contactor Coil Only.

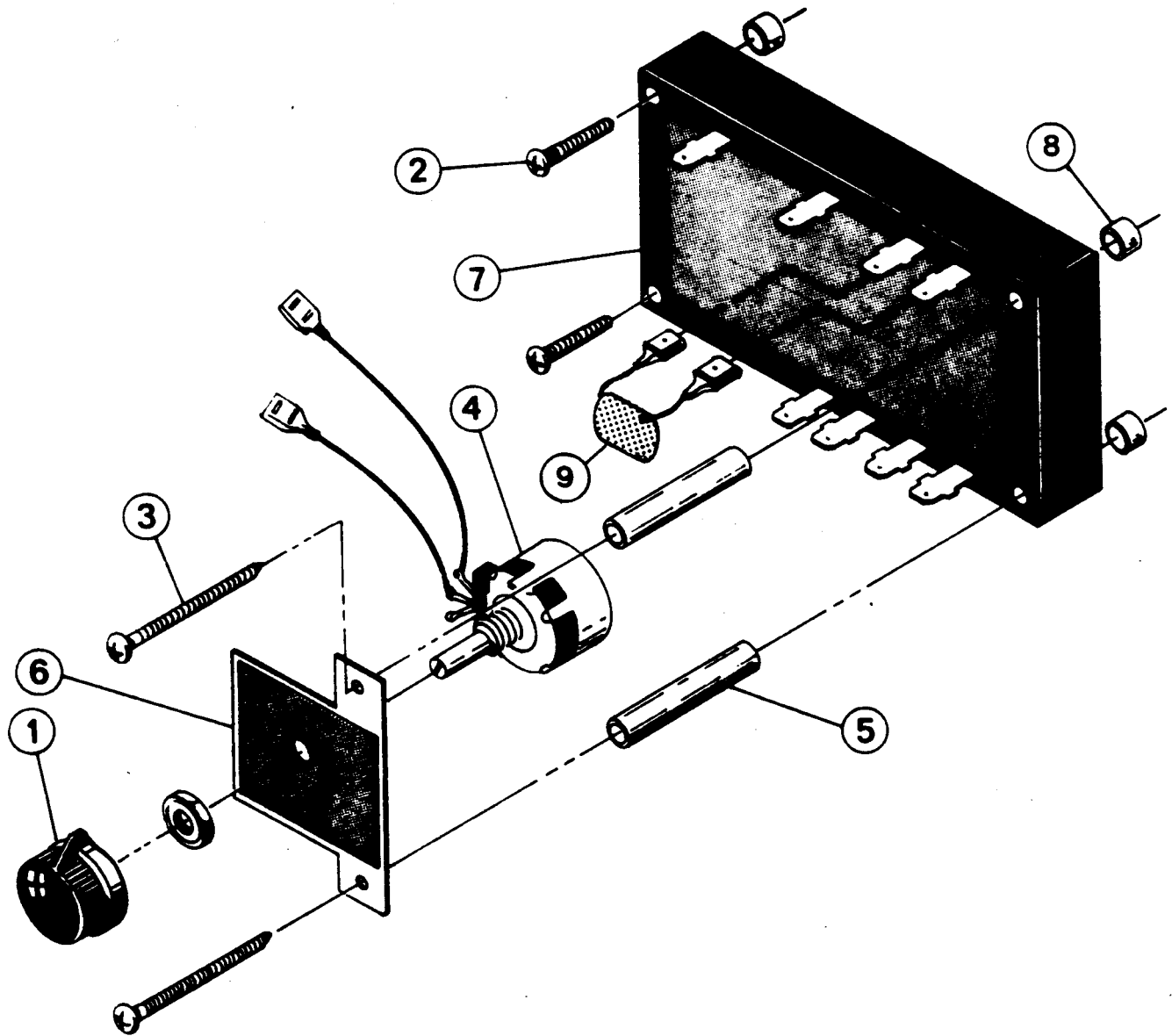

SOLID STATE REVERSING CONTROL

<u>Ref. No.</u>	<u>Part No.</u>	<u>Description</u>
1	PT118	Knob
2	TU3416	#8x1½" Phillips Pan Hd. Screw (2 req'd.)
3	TU9929	#8 x 2½ Phillips Pan Hd. Screw (2 req'd.)
4	TU9946	Potentiometer & Wire Assembly
5	TU9924	Spacers (2 req'd.)
6	TU10039	Potentiometer Bracket W/Label
7	TU9921	Reversing Control - 120V. 50/60 Hz.
	TU9922	Reversing Control - 240V. 50/60 Hz.
8	TU10128	Nylon Spacers (4 req'd.)
9	TU10127	Capacitor & Terminal Assy.

Instructions for Dryers With Solid State Reversing Control

1. Reversing timer operates 30 seconds in each direction (clockwise and counter-clockwise.)
2. Stop time ("off time") is adjustable from 4-10 seconds, in one second increments.

Set "off time" on potentiometer in the reversing control box on the dryer.

Fan Rotation

Note: The fan rotates counter-clockwise as viewed from the back end of the motor (see arrow on motor support).

To change rotation, reverse the power leads L1 & L2.

Fan and Basket Rotation on Dryers Without Reversing Controls

Note: The fan rotates counter-clockwise as viewed from the back end of the motor (see arrow on motor support).

Basket rotates clockwise as viewed from the front of the tumbler.

To change rotation of both fan and basket, reverse power leads L1 and L2.

To change rotation of fan only, reverse motor leads F1 and F2.

To change rotation of basket only, reverse motor leads B1 and B2.

