

DRYER

Repair Parts List

MODEL NUMBER
MLG15PDAWQ

When requesting service or ordering parts, always provide the following information:

- Product Type
- Part Number
- Model Number
- Part Description

MAYTAG®

©2005 Maytag Services

Section: CONTROL PANEL (UPPER)

Model: MLG15PDAWQ

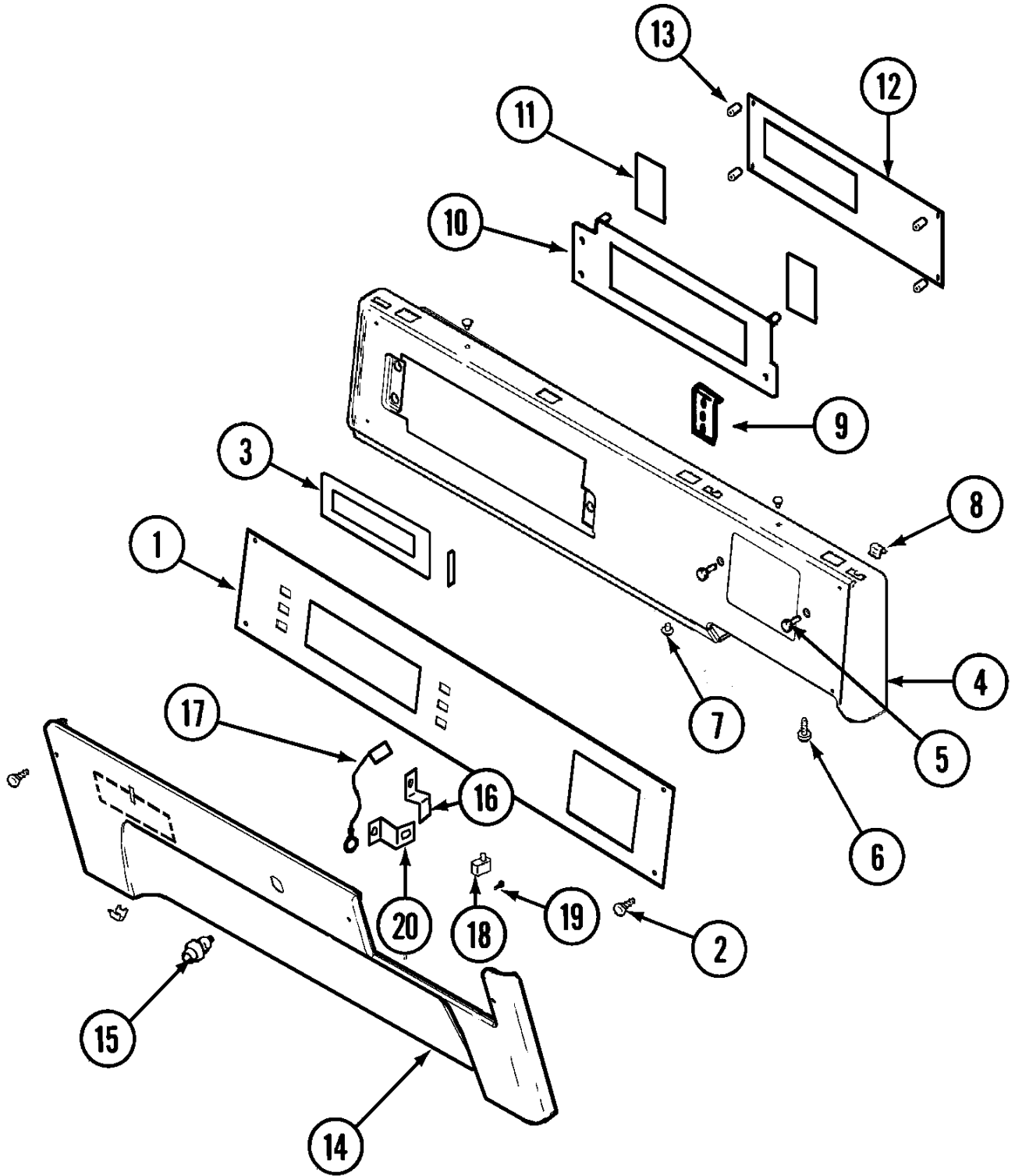

LD11-77

Section: CONTROL PANEL (UPPER)

No.	Part No.	Description	Series	Qty
1	33001974	OVERLAY, CONTROL PANEL	10	1
2	215506	SCREW, TORX Note: SCREW, CONTROL PANEL OVERLAY	10	4
3	33001209	COVER, DISPLAY (LOWER) Note: COVER, DISPLAY	10	1
4	33002377	PANEL, CONTROL (BSQ) Note: (BSQ)	10	1
-	33002003	FASTENER CLIP, CONTROL PANEL	10	2
5	22002062	SCREW Note: SCREW, CONTROL MOUNTING	10	3
5	910186	SCREW Note: SCREW, CONTROL PANEL	10	2
6	215506	SCREW, TORX Note: SCREW, CONTROL PANEL (TORX)	10	3
7	33002342	PLUG, HOLE (BSQ) Note: (BSQ)	10	4
8	33001977	FASTENER, CONTROL PANEL	10	3
9	33001156	BUTTON Note: BUTTON, CONTROL	10	2
10	33001201	PLATE, CONTROL MOUNTING	10	1
11	33001200	SWITCH, MEMBRANE	10	2
12	33001747	BOARD ASSY., CONTROL Note: CIRCUIT BOARD ASSEMBLY	10	1
-	912077	LOCKNUT Note: LOCKNUT, WASHER	10	4
13	33001204	STANDOFF, CIRCUIT BOARD	10	4
-	33002004	CLIP, FASTENER	10	2
14 N	33002376	PANEL, ACCESS (BSQ) Note: (BSQ)	10	1
-	33001980	CLIP, ACCESS PANEL Note: FASTENER, ACCESS PANEL	10	2
-	215506	SCREW, TORX Note: SCREW, ACCESS PANEL (TORX)	10	3
15	206081	LOCK FOR ACCESS DOOR Note: LOCK, ACCESS DOOR	10	1
16	213750	LOCKING CAM	10	1
17	33001981	WIRE, GROUND	10	1
18	33002117	SWITCH, SENSOR	10	1
19	912012	SCREW	10	2
20	33001982	BRACKET, SWITCH MOUNTING	10	1
-	33002052	WIRE HARNESS, MAIN (UPR)	10	1
-	33002060	BRACKET, SECURITY	10	1
-	22001995	SCREW Note: SCREW, SECURITY	10	2
- N	33002045	NUT, SECURITY	10	4

*Color Code (-)=Not Shown #=Series, Serial Prefix or Run No., N=Not Available

Section: CONTROL CENTER (UPPER)

Model: MLG15PDAWQ

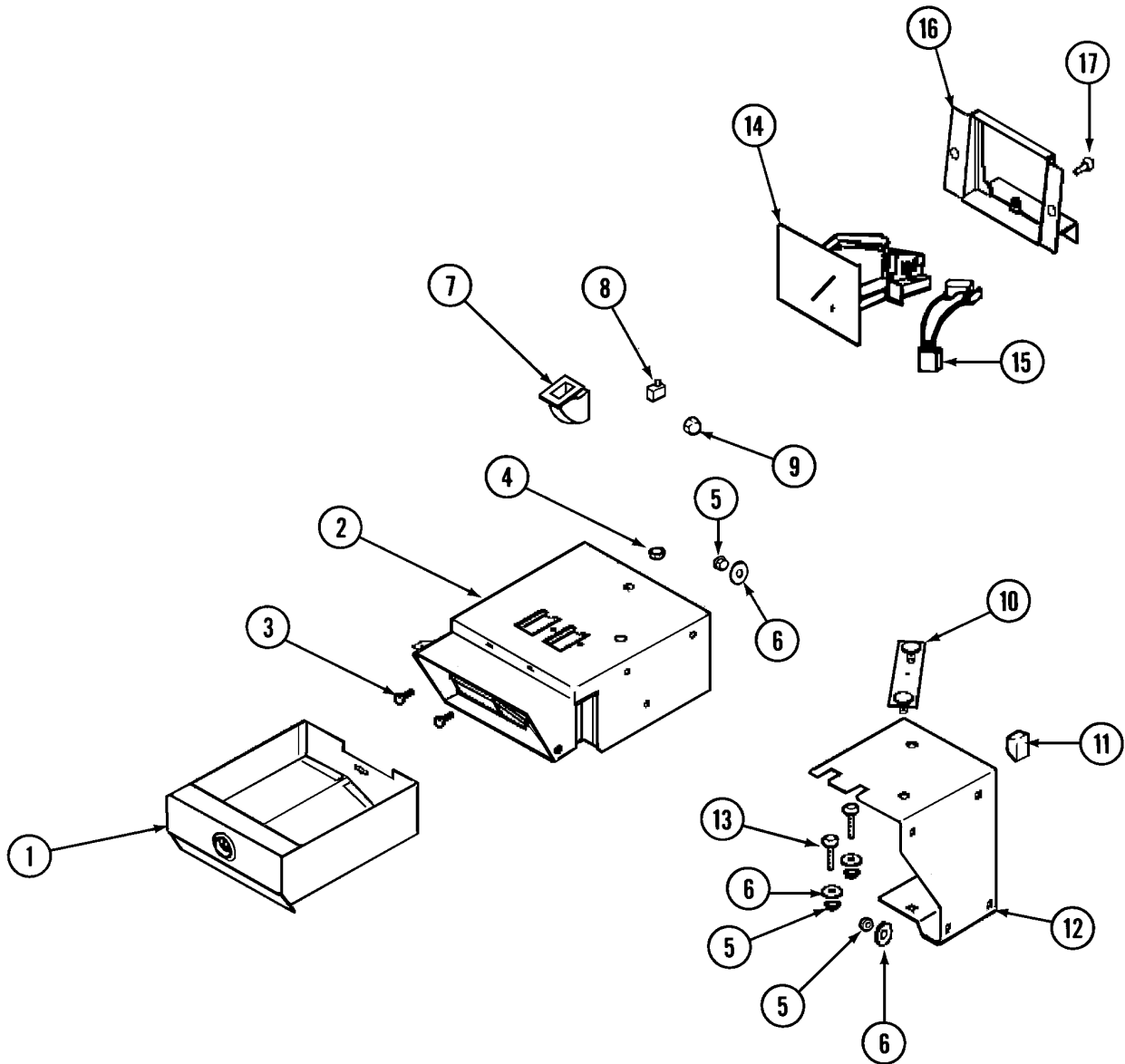

Section: CONTROL CENTER (UPPER)

No.	Part No.	Description	Series	Qty
1	33002443	BOX, COIN (BSQ) Note: (BSQ)	10	1
2	33002444	VAULT, COIN (BSQ) Note: (BSQ)	10	1
3	212707	SCREW Note: SCREW, COIN DROP MOUNTING BRK.	10	2
4	052740	NUT Note: NUT, COIN VAULT	10	2
5	052734	NUT Note: NUT, CARRAGE BOLTS & BRACKET	10	7
6 N	211629	WASHER Note: WASHER, VAULT MOUNTING BRK.	10	7
6	312535	WASHER, ROLLER SHAFT Note: WASHER, VAULT MOUNTING BRK.	10	1
7	314635	COIN CHUTE Note: CHUTE, COIN	10	2
8	33001250	SWITCH, SENSOR Note: SWITCH, VAULT	10	1
9 N	211782	CAGE NUT Note: NUT, CAGE	10	1
10	22001810	STRAP, MOUNTING	10	1
11	33001989	RETAINER, WIRE	10	1
12	33001990	BRACKET, MOUNTING VAULT	10	1
13	33001991	BOLT, CARRIAGE	10	2
14	22001873	DROP ASSY., COIN	10	1
-	22002144	SINGLE FACEPLATE	10	1
-	216200	BUTTON, RETURN Note: BUTTON, RETURN	10	1
15	33001985	SWITCH, OPTIC	10	1
-	314665	SCREW Note: SCREW, OPTIC SWITCH	10	1
16	33002445	BRACKET, COIN DROP MOUNT.(BSQ) Note: (BSQ)	10	1
17 N	313561	SCREW----NA Note: SCREW, COIN DROP BRACKET	10	2
-	910181	LOCK WASHER Note: WASHER, LOCK	10	2

*Color Code (-)=Not Shown #=Series, Serial Prefix or Run No., N=Not Available

Section: CABINET-FRONT (UPPER)

Model: MLG15PDAWQ

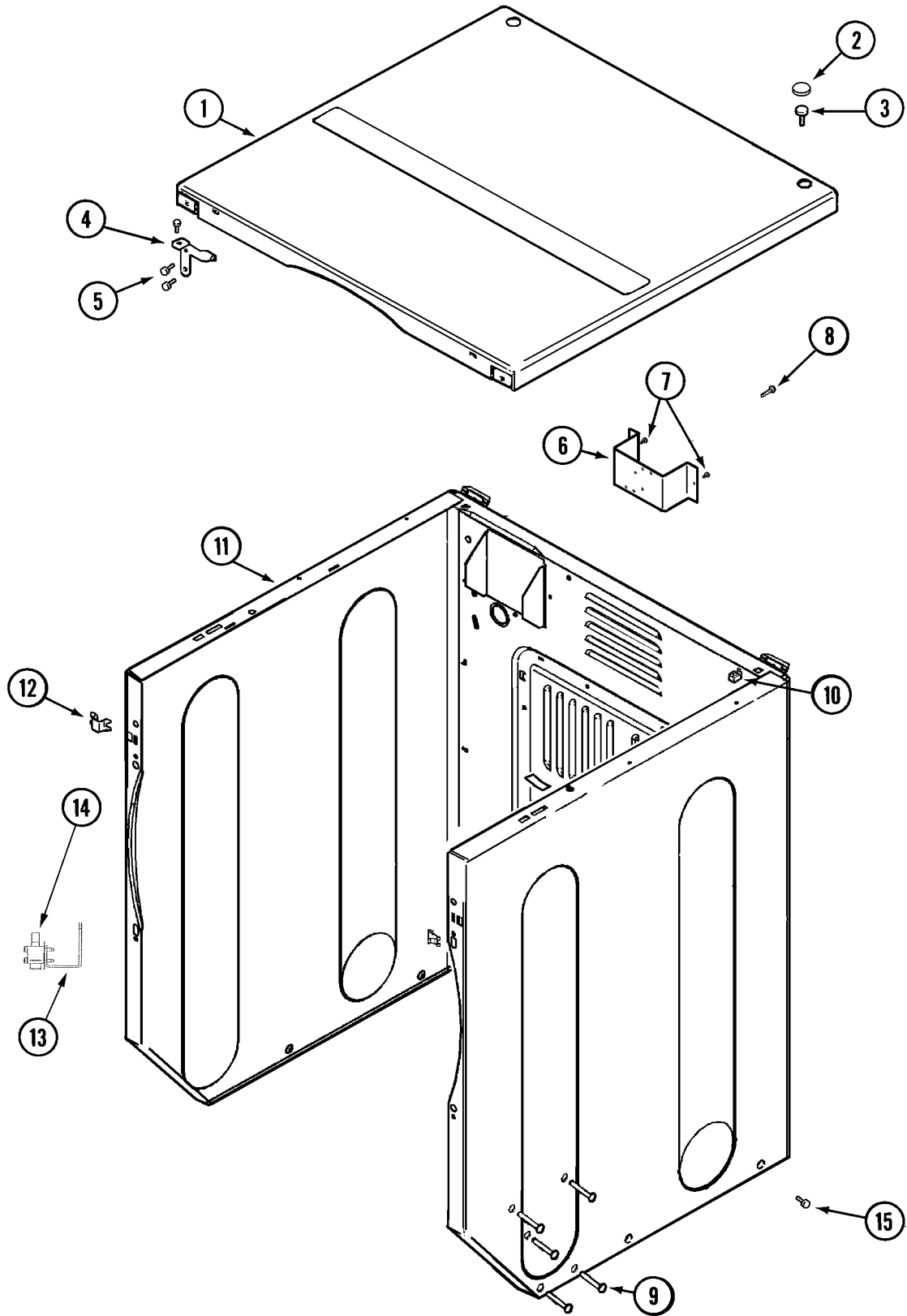

LD12-35

Section: CABINET-FRONT (UPPER)

No.	Part No.	Description	Series	Qty
1	N 33002369	COVER, TOP (BSQ) Note: (BSQ)	10	1
2	33001997	PLUG, HOLE	10	2
3	22001883	SCREW Note: SCREW, TOP COVER	10	2
4	33001998	BRACKET, TOP COVER (LT)	10	1
4	33001999	BRACKET, TOP COVER (RT) Note: (RT)	10	1
5	22001995	SCREW Note: SCREW, TOP COVER BRACKET	10	6
6	N 33001826	BRACKET, TERMINAL BLOCK----NA	10	1
7	22001995	SCREW Note: SCREW, TERMINAL BLOCK BRACKET	10	2
8	N 33001245	SCREW----NA Note: SCREW, GROUND LUG	10	1
9	N 313363	WASHER Note: WASHER, GROUND LUG	10	1
10	22001502	FASTENER, U-NUT	10	2
11	33002378	CABINET (BSQ) Note: (BSQ)	10	1
12	33001980	CLIP, ACCESS PANEL	10	2
-	310632	SCREW Note: SCREW, RELAY BRACKET	10	1
-	N 313561	SCREW----NA Note: SCREW, RELAY BRACKET	10	2
13	33002002	BRACKET, RELAY (UPR)	10	1
-	251119	SCREW Note: SCREW, RELAY	10	1
14	206824	RELAY, SPST 24VDC Note: RELAY	10	1
15	213007	SCREW, CABINET	10	6
16	33001991	BOLT, CARRIAGE	10	5

*Color Code (-)=Not Shown #=Series, Serial Prefix or Run No., N=Not Available

Section: CABINET-FRONT (LOWER)

Model: MLG15PDAWQ

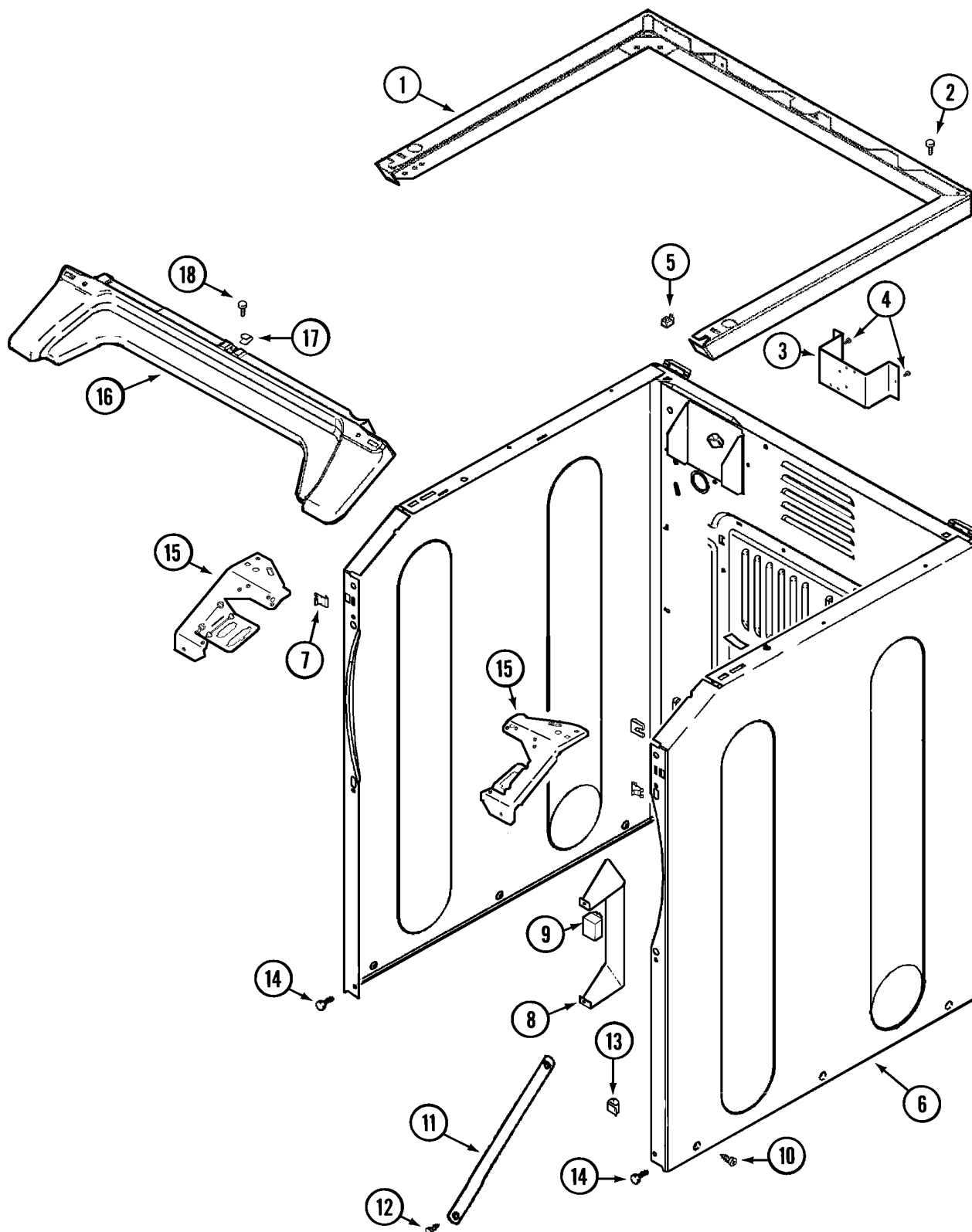

LD12-37

Section: CABINET-FRONT (LOWER)

No.	Part No.	Description	Series	Qty
1	33002446	SUPPORT, CABINET (BSQ) Note: (BSQ)	10	1
2	22001883	SCREW Note: SCREW, SUPPORT	10	4
3	N 33001826	BRACKET, TERMINAL BLOCK----NA	10	1
4	22001995	SCREW Note: SCREW, TERMINAL BLOCK	10	2
5	22001502	FASTENER, U-NUT	10	2
6	N 22003640	CABINET ASSY. (BISQUE AS PK)	38	1
6	22002659	CABINET ASSY. (BSQ) Note: (BSQ)	10	1
7	22002049	CLIP Note: CLIP, FRONT PANEL	10	2
-	N 313561	SCREW----NA Note: SCREW, RELAY BRACKET	10	2
-	310632	SCREW Note: SCREW, RELAY BRACKET	10	1
8	314627	RELAY BRACKET Note: BRACKET, RELAY	10	1
-	251119	SCREW Note: SCREW, RELAY	10	1
9	206824	RELAY, SPST 24VDC	10	1
10	213007	SCREW, CABINET	10	6
11	22002259	BRACE, CROSS	10	2
12	22001995	SCREW Note: SCREW, CROSS BRACE	10	2
13	310376	CLIP, WIRE HARNESS	10	1
14	22001995	SCREW Note: SCREW, CABINET	10	2
15	33002009	BRACKET, CORNER (LT)	10	1
15	33002010	BRACKET, CORNER (RT) Note: (RT)	10	1
16	22002664	COVER, ACCESS (BSQ)	10	1
17	33002013	FASTENER CLIP, ACCESS COVER Note: FASTENER, ACCESS COVER	10	1
18	22001995	SCREW Note: SCREW, ACCESS COVER	10	1
-	33002054	WIRE HARNESS, MAIN (LWR)	10	1
-	33001989	RETAINER, WIRE Note: RETAINER, WIRE HARNESS	10	2

*Color Code (-)=Not Shown #=Series, Serial Prefix or Run No., N=Not Available

Section: DOOR (UPPER)

Model: MLG15PDAWQ

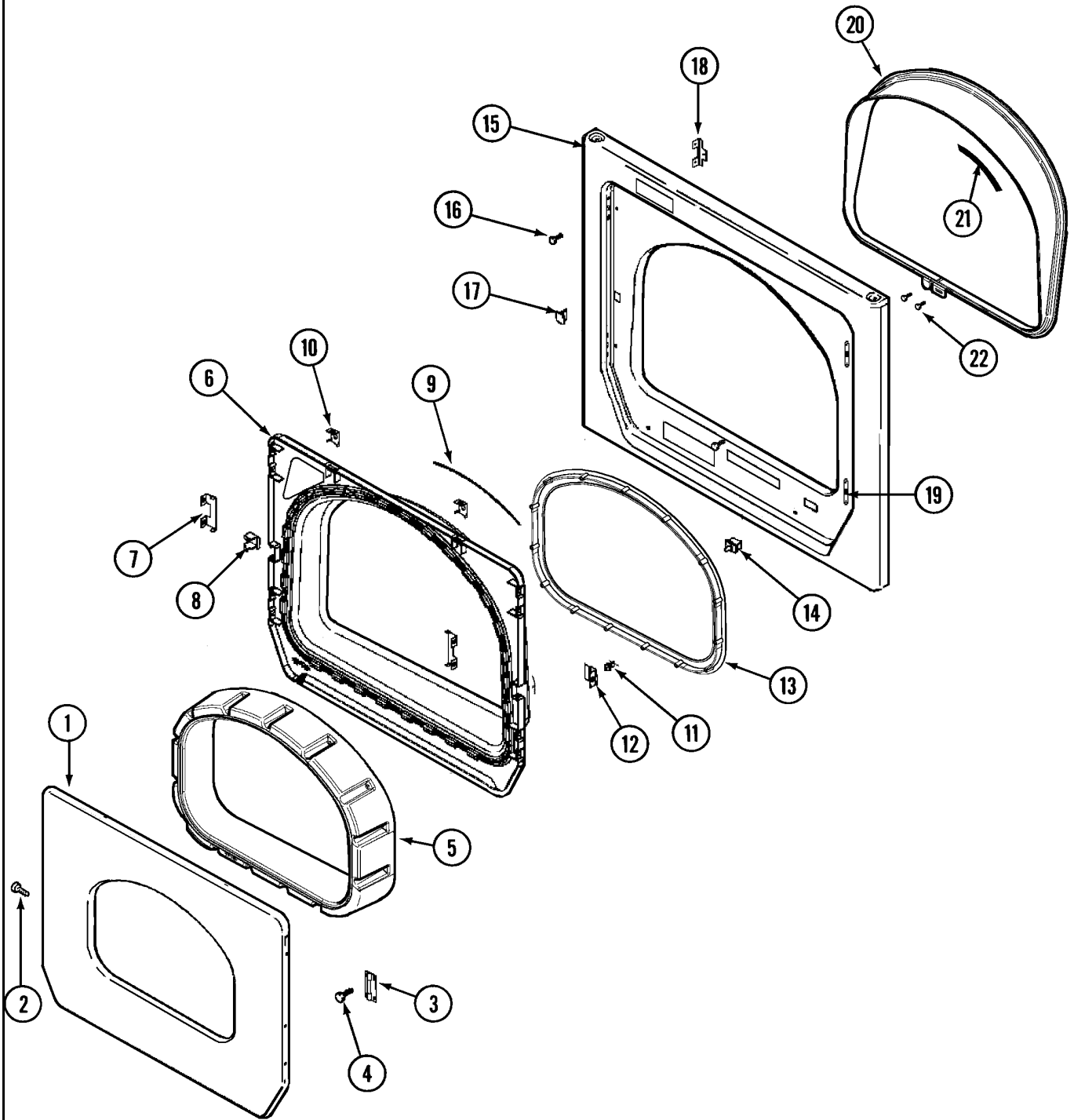

LD17-15

Section: DOOR (UPPER)

No.	Part No.	Description	Series	Qty
1	N 33002370	DOOR, OUTER (BSQ) Note: DOOR, OUTER (BSQ)	10	1
2	33002351	SCREW (#8-18 OUTER DOOR (BSQ) Note: SCREW, OUTER DOOR (BSQ)	10	8
3	33002017	HINGE, DOOR	10	2
4	22002062	SCREW Note: SCREW, HINGE	10	4
5	33002018	TUNNEL (WHT)	10	1
-	22002300	SCREW Note: SCREW, TUNNEL	10	15
6	33002020	DOOR, INNER (WHT)	10	1
7	22002038	CLIP, DOOR (DOUBLE)	10	4
8	33001763	PLUG, INNER DOOR	10	1
9	33002094	SEAL, DOOR	10	1
10	22002039	CLIP, DOOR (SINGLE) Note: CLIP, INNER DOOR	10	2
11	33001761	STRIKE, DOOR (MALE)	10	1
12	33001793	BRACKET, STRIKE	10	1
13	33002607	LENS	33	1
13	33002022	LENS	10	1
14	33002038	SWITCH, DOOR (LWR) Note: SWITCH, DOOR	10	1
-	33001711	NAMEPLATE	10	1
15	33002381	PANEL, FRONT (BSQ) Note: PANEL, FRONT (BSQ)	10	1
-	33002051	SCREW, TORX Note: SCREW, FRONT PANEL	10	2
16	33001486	PANEL, FASTENER	10	4
17	33001791	CATCH, DOOR (W/PLUG)	10	1
18	33002025	TWIN SPEEDNUT	10	4
19	33002343	COVER, HOLE (BSQ) Note: COVER, HINGE HOLE (BSQ)	10	2
20	33002026	EXTENSION, TUMBLER FRONT	10	1
21	33001767	SEAL, SHROUD	10	1
22	33001855	SCREW (HEX HEAD) Note: SCREW, TUMBLER FRONT EXTENSION	10	2

*Color Code (-)=Not Shown #=Series, Serial Prefix or Run No., N=Not Available

Section: CABINET-REAR

Model: MLG15PDAWQ

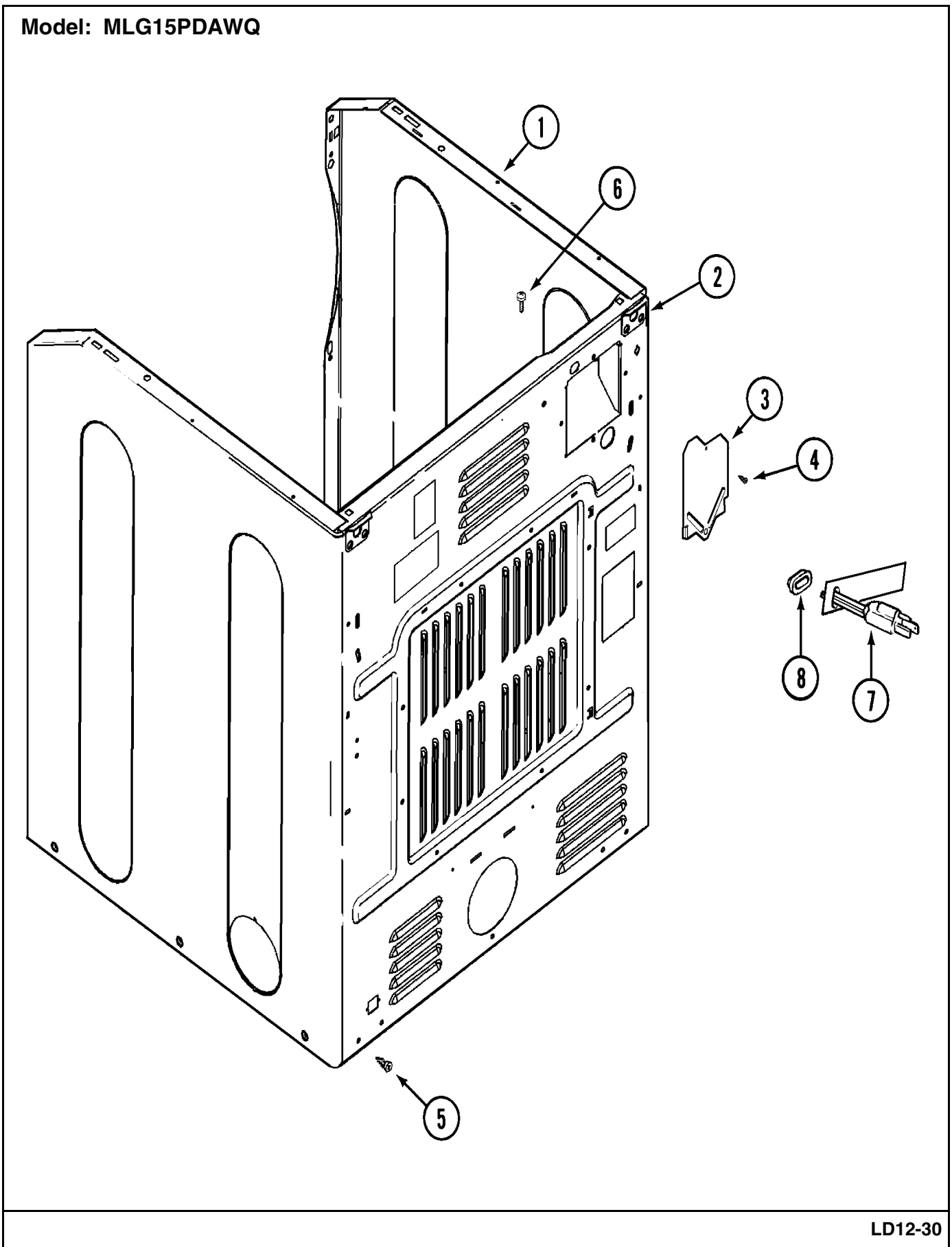

LD12-30

Section: CABINET-REAR

No.	Part No.	Description	Series	Qty
1	22002659	CABINET ASSY. (BSQ) Note: (BSQ-LWR)	10	1
1	33002378	CABINET (BSQ) Note: (BSQ-UPR)	10	1
-	310376	CLIP, WIRE HARNESS Note: CLIP, WIRE HARNESS (LWR)	10	1
2	N 33001827	BRACKET, CABINET HINGE Note: BRACKET, CABINET HINGE (LWR)	10	2
3	33001795	COVER, TERMINAL BLOCK	10	2
4	22001995	SCREW Note: SCREW, TERMINAL COVER	10	2
5	22001995	SCREW Note: SCREW, CABINET BACK	10	4
6	210186	SCREW, GROUND WIRE TO BASE--NA Note: SCREW, POWER CORD GROUND	10	2
7	208784	CORD, POWER	10	2
8	211881	GROMMET, CORD	10	1

*Color Code (-)=Not Shown #=Series, Serial Prefix or Run No., N=Not Available

Section: TUMBLER

Model: MLG15PDAWQ

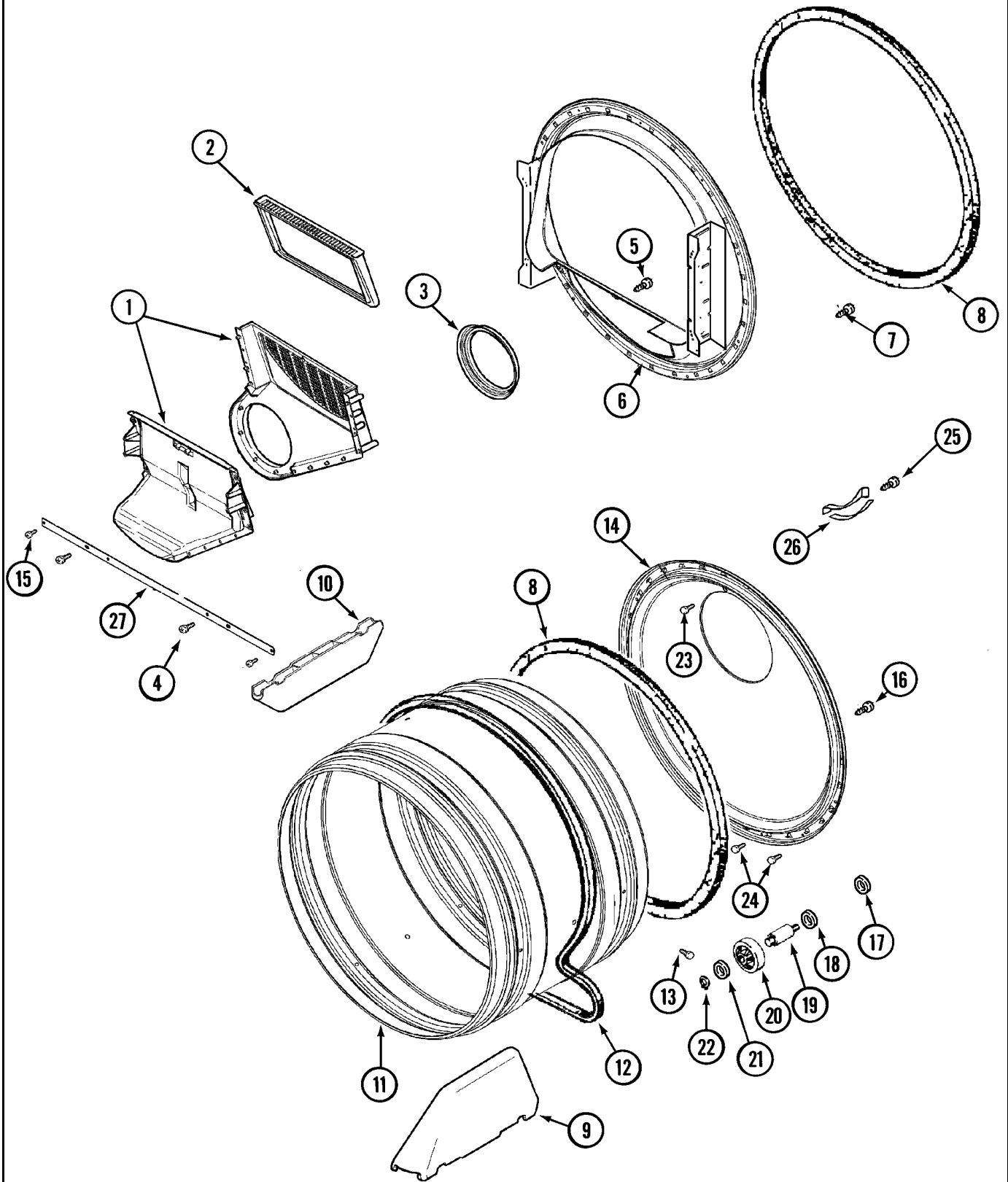

LD13-44

Section: TUMBLER

No.	Part No.	Description	Series	Qty
1	33001799	OUTLET DUCT ASSEMBLY	10	2
2	33001804	FILTER, LINT	10	2
3	33001758	SEAL, BLOWER	10	2
4	33001768	SCREW, SHROUD Note: SCREW, TUMBLER BRACE (UPR)	10	2
5	N 312311	SCREW---NA Note: SCREW, OUTLET DUCT	10	2
6	33001802	FRONT, TUMBLER (W/SEAL)	10	2
7	33001855	SCREW (HEX HEAD) Note: SCREW, OUTLET DUCT	10	8
8	33001807	SEAL, TUMBLER	10	4
9	33002032	BAFFLE (TALL)	10	4
10	33001755	BAFFLE (SHORT)	10	2
11	33001794	TUMBLER	10	2
12	33001777	BELT, TUMBLER	10	2
13	33001788	SCREW, BAFFLE	10	12
14	33001801	BACK, TUMBLER (W/SEAL)	10	2
15	22001995	SCREW Note: SCREW, TUMBLER BRACE (UPR)	10	2
16	22001995	SCREW Note: SCREW, TUMBLER BACK	10	8
17	33001443	NUT, HEX (ROLLER SHAFT)	10	4
18	313347	WASHER, SPRING (ROLLER SHAFT)	10	4
19	312948	SHAFT, TUMBLER ROLLER	10	4
20	303373	BEARING & ROLLER ASSEMBLY Note: ROLLER (W/BEARING)	10	4
21	312535	WASHER, ROLLER SHAFT	10	4
22	410233	RING, RETAINING	10	4
23	210932	SCREW, #8 X 9/16 CTSK Note: SCREW, INLET DUCT	10	2
24	22001996	SCREW Note: SCREW, INLET DUCT	10	4
25	210720	RIVET	10	8
26	306508	TUMBLER BEARING KIT	10	4
27	33002039	BRACE, TUMBLER FRONT Note: BRACE, TUMBLER FRONT (UPR)	10	1

*Color Code (-)=Not Shown #=Series, Serial Prefix or Run No., N=Not Available

Section: GAS VALVE

Model: MLG15PDAWQ

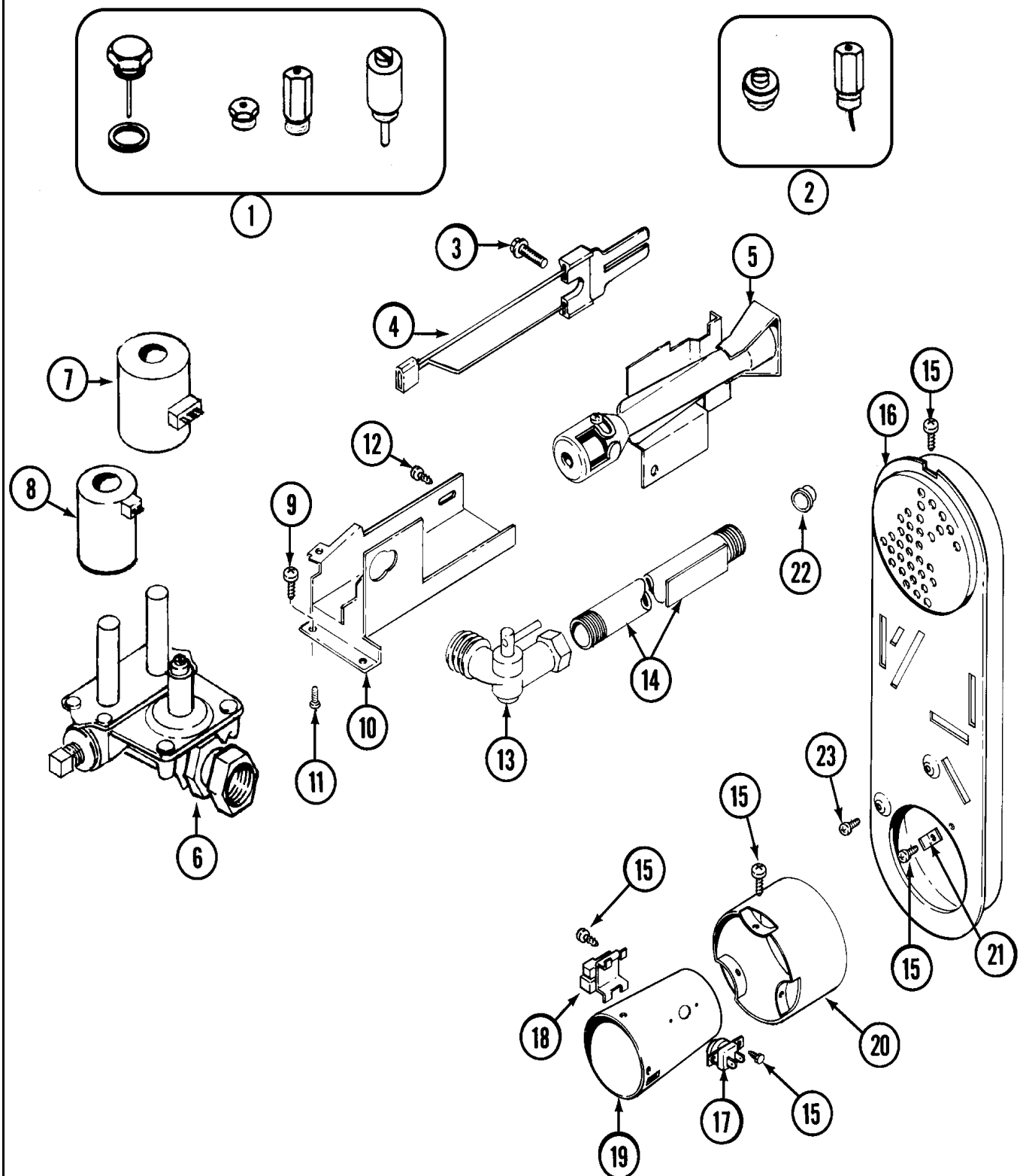

Section: GAS VALVE

No.	Part No.	Description	Series	Qty
1	308378	CONVERSION KIT (NATURAL TO LP)	10	2
2	308377	CONVERSION KIT (LP TO NATURAL)	10	2
3	304971	SCREW Note: SCREW, IGNITER	10	2
4	304970	IGNITER ASSY, GAS VALVE	10	2
5	33001247	BURNER ASSY.	10	2
-	33002056	PLUG, HOLE Note: PLUG, HOLE (UPR)	10	2
6	308345	VALVE, GAS	10	2
7	306106	COIL, HOLDING & BOOSTER	10	2
8	306105	COIL, SECONDARY	10	2
9 N	313561	SCREW----NA Note: SCREW, GAS VALVE	10	4
10 N	33002055	BRACKET, GAS VALVE----NA Note: BRACKET, GAS VALVE (UPR)	10	1
10 N	33001834	BRACKET, GAS VALVE----NA Note: BRACKET, GAS VALVE (LWR)	10	1
11	314082	SCREW Note: SCREW, GAS VALVE	10	2
11	314568	SCREW-GAS VALVE TO BRACKET Note: SCREW, GAS VALVE	10	2
12	22001995	SCREW Note: SCREW, GAS VALVE	10	2
13	306086	ANGLE SHUT OFF FOR GAS VALV Note: VALVE, ANGLE GAS	10	2
14	33001735	PIPE & BRACKET ASSY.	10	2
15	211294	SCREW Note: SCREW, DUCT	10	14
16	33001810	DUCT ASSY., INLET (GAS) Note: INLET DUCT ASSEMBLY	10	2
17	305169	THERMOSTAT, HI-LIMIT GAS	10	2
18	303377	SENSOR, RADIANT	10	2
19	33001835	CONE ASSY., COMBUSTION	10	2
20	303841	CONE, EXTENSION (COMBUSTION)	10	2
21	312890	RETAINER, HEATER CHAMBER	10	2
22	33001693	CAP, GAS PIPE	10	2
23	22001996	SCREW Note: SCREW, DUCT	10	8

*Color Code (-)=Not Shown #=Series, Serial Prefix or Run No., N=Not Available

Section: MOTOR DRIVE

Model: MLG15PDAWQ

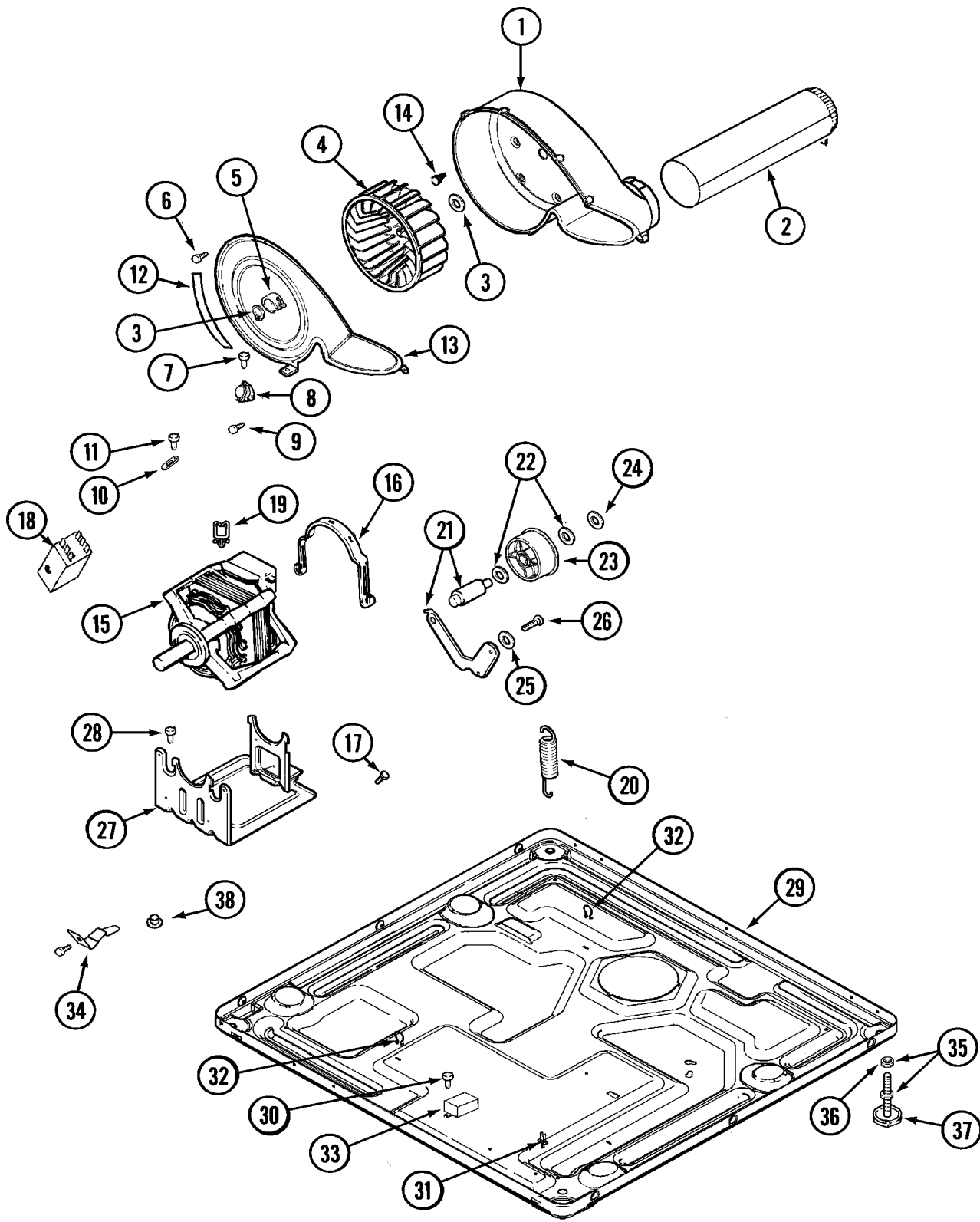

Section: MOTOR DRIVE

No.	Part No.	Description	Series	Qty
1	33001789	HOUSING, BLOWER	10	2
-	22001995	SCREW Note: SCREW, EXHAUST DUCT ASSEMBLY	10	2
2	33001800	DUCT ASSY., EXHAUST	10	2
3	410233	RING, RETAINING	10	4
4	33001790	WHEEL, BLOWER	10	2
5	312967	CLAMP, BLOWER HOUSING	10	2
6	33001855	SCREW (HEX HEAD) Note: SCREW, HOUSING COVER	10	16
7	N 313561	SCREW----NA Note: SCREW, HOUSING COVER	10	2
8	33303391	THERMOSTAT, CYCLING	10	2
-	307208	THERMISTOR, TEMP. CONTROL	10	2
9	22001996	SCREW Note: SCREW, THERMOSTAT	10	8
10	33001762	FUSE, THERMAL (W' BRACKET)	10	2
11	314848	SCREW Note: SCREW, THERMAL CUT-OFF	10	2
12	N 33001772	SEAL, BLOWER COVER	10	2
13	33001796	COVER, BLOWER HOUSING	10	2
14	314818	SCREW Note: SCREW, BLOWER HOUSING	10	8
15	33001853	MOTOR (W/PULLEY)	10	2
15	33002462	MOTOR (120V 60HZ)	15	1
15	33002478	MOTOR	18	1
16	015825	CLIP, MOTOR	10	4
17	910343	SCREW, GROUND WIRE	10	4
18	33001854	SWITCH, MOTOR	10	2
19	33002040	CLIP, WIRE HARNESS	10	2
-	33002461	PLUG FOR SPRING	14	1
-	33002157	GROMMET	10	1
20	33002460	SPRING, IDLER	14	1
20	33001754	SPRING, IDLER	10	2
21	33001840	IDLER ARM & SHAFT ASSY.	10	2
22	312527	WASHER, IDLER SHAFT (QTY-1)	10	4
23	33001783	BEARING, IDLER ASSEMBLY	10	2
24	312958	RETAINING RING, IDLER SHAFT	10	2
25	315772	SLEEVE, IDLER ARM	10	2
26	014874	SCREW	10	2
27	33001752	SUPPORT, MOTOR	10	2
-	N 313561	SCREW----NA Note: SCREW, SUPPORT	14	1
27	33002466	SUPPORT, MOTOR	14	1
28	N 313561	SCREW----NA Note: SCREW, MOTOR SUPPORT	10	4
-	314568	SCREW-GAS VALVE TO BRACKET Note: SCREW, HARNESS PROTECTOR (UPR)	10	2
-	33002049	STRIP, GROMMET Note: STRIP, GROMMET (UPR)	10	2
29	33001845	BASE Note: BASE (LWR)	10	1
-	33002048	FASTENER, PUSH Note: FASTENER, PUSH (UPR)	10	2
29	N 33002465	BASE, (LWR)----NA	14	1
-	33002050	PROTECTOR, HARNESS Note: PROTECTOR, HARNESS (UPR)	10	2
29	33002041	BASE (UPR)	10	1
29	N 33002465	BASE, (LWR)----NA	38	1
29	33002467	BASE (UPR)	38	1
29	33002467	BASE (UPR)	14	1
30	211294	SCREW Note: SCREW, TRANSFORMER (LWR)	10	2
31	315471	RETAINER, WIRE	10	1
32	410490	SPRING, WIRE HARNESS	10	2
-	313559	SCREW Note: SCREW, TRANSFORMER SHIELD (LWR)	10	2
-	315218	SHIELD, XFMER Note: SHIELD, TRANSFORMER (LWR)	10	1
33	33001205	TRANSFORMER Note: TRANSFORMER (LWR)	10	1
-	22002244	CLIP, GROUNDING Note: CLIP, GROUNDING (LWR)	10	1
-	22001995	SCREW Note: SCREW, BRACKET (UPR)	10	2
34	33002043	BRACKET (RT) Note: (RT-UPR)	10	1

*Color Code (-)=Not Shown #=Series, Serial Prefix or Run No., N=Not Available

Section: MOTOR DRIVE

Model: MLG15PDAWQ

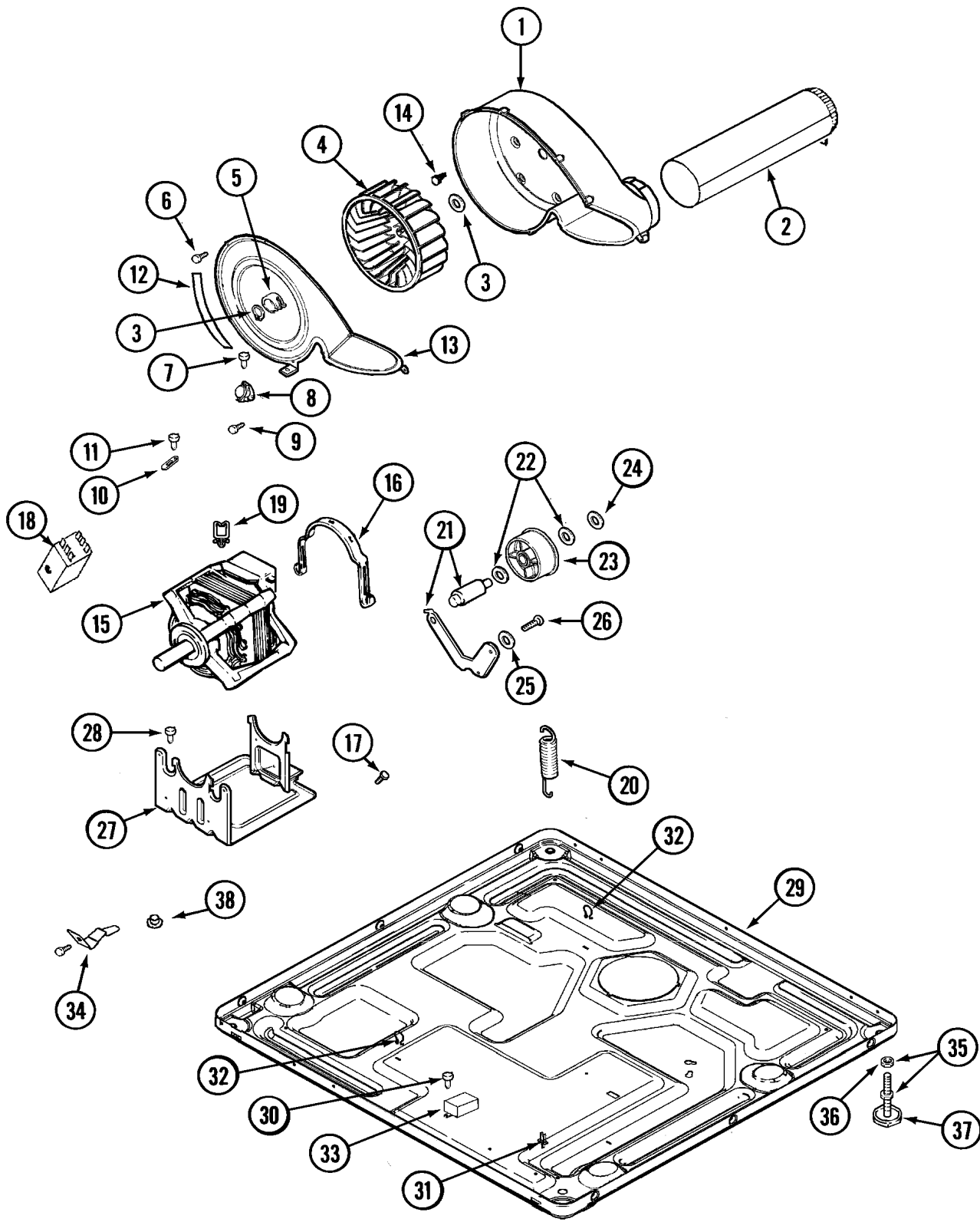

Section: MOTOR DRIVE

No.	Part No.	Description	Series	Qty
34	22002239	CLIP, LOWER FRONT PANEL Note: CLIP, FRONT PANEL (LWR)	10	2
-	310632	SCREW Note: SCREW, FRONT PANEL CLIP (LWR)	10	2
34	33002042	BRACKET (LT) Note: BRACKET (LT-UPR)	10	1
35	22001915	ADJUSTABLE LEG & NUT Note: ADJUSTABLE LEG & NUT (LWR)	10	4
36	052740	NUT Note: NUT, LEG (LWR)	10	4
37	210684	FOOT, RUBBER Note: FOOT, RUBBER (LWR)	10	4
38	33002044	GUIDE Note: GUIDE (UPR)	10	2

*Color Code (-)=Not Shown #=Series, Serial Prefix or Run No., N=Not Available

Section: WIRING INFORMATION

Model: MLG15PDAWQ

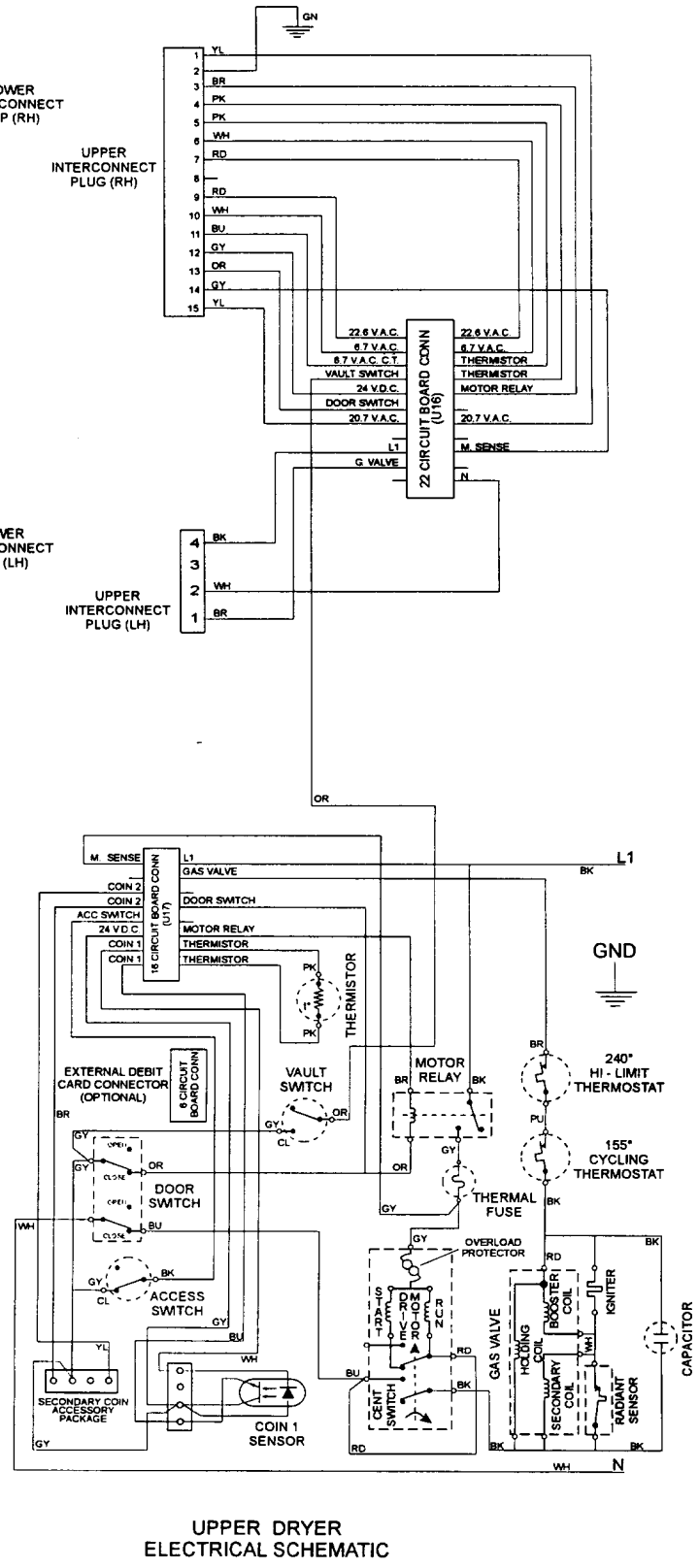
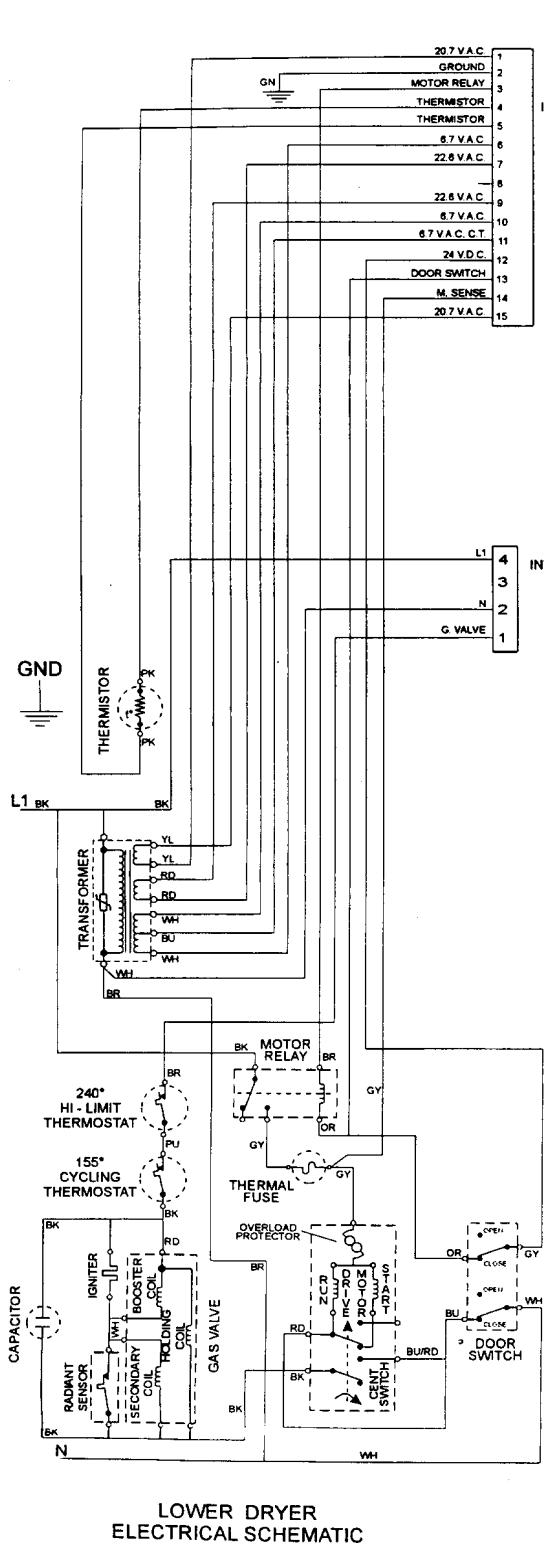

15002382

