

STACK LAUNDRY

Repair Parts List

MODEL NUMBER
MLG19PDAGW

When requesting service or ordering parts, always provide the following information:

- Product Type
- Part Number
- Model Number
- Part Description

MAYTAG®

©2005 Maytag Services

Section: CONTROL PANEL (DRYER)

Model: MLG19PDAGW

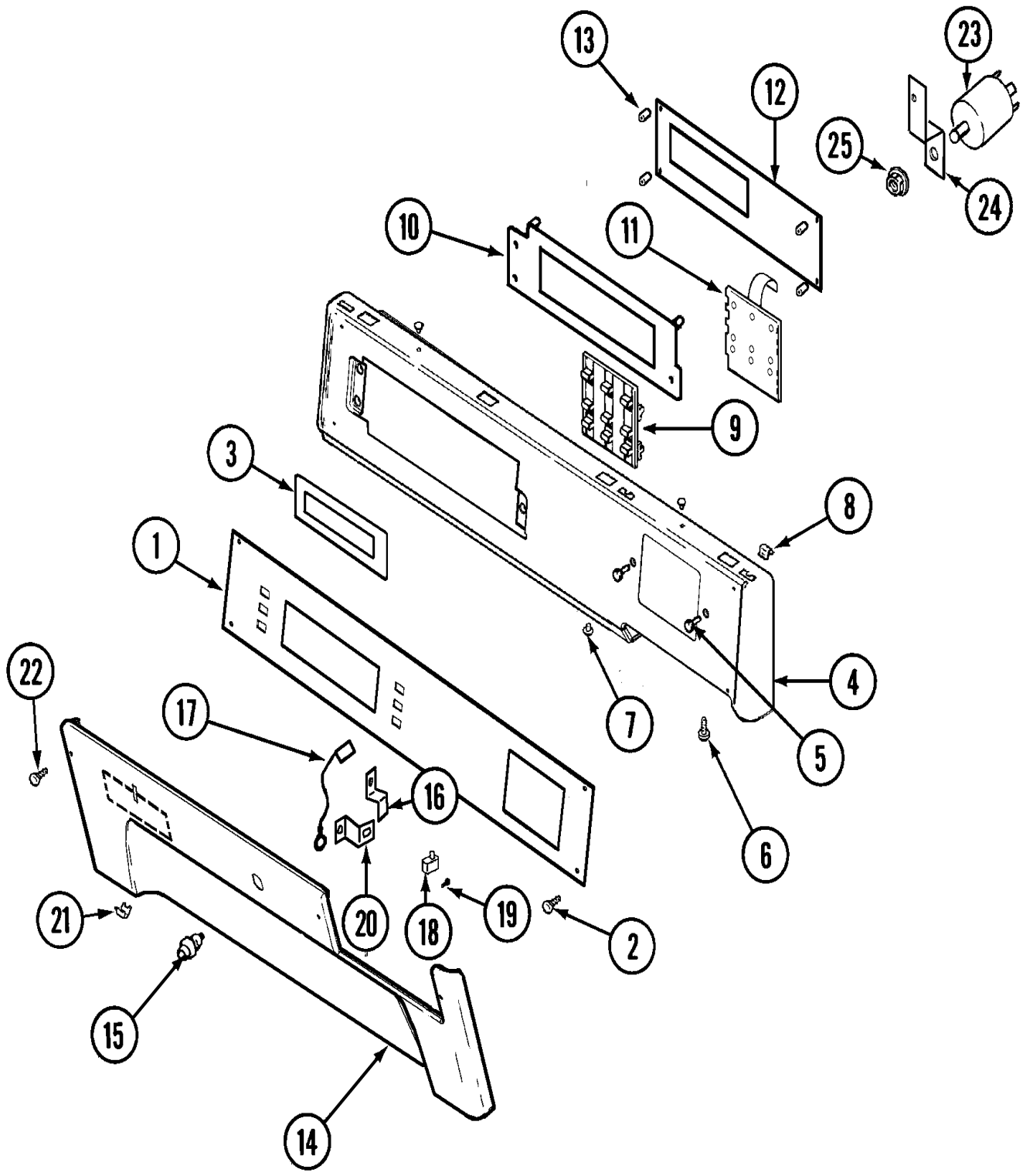

Section: CONTROL PANEL (DRYER)

No.	Part No.	Description	Series	Qty
1	33002148	OVERLAY, CONTROL PANEL (WHT)	10	1
2	215506	SCREW, TORX Note: SCREW, CONTROL PANEL OVERLAY	10	4
3	33002150	COVER, DISPLAY Note: COVER, DISPLAY	10	1
4	33002149	PANEL, CONTROL (WHT)	10	1
-	33002003	FASTENER CLIP, CONTROL PANEL	10	2
5	22002062	SCREW Note: SCREW, CONTROL MOUNTING	10	3
5	910186	SCREW Note: SCREW, CONTROL PANEL	10	2
6	215506	SCREW, TORX Note: SCREW, CONTROL PANEL (TORX)	10	3
7	33001132	PLUG, SIGHT HOLE (WHT)	10	2
8	33001977	FASTENER, CONTROL PANEL	10	3
9	33002178	SWITCH, PUSH BUTTON	10	1
10	33002155	PLATE, CONTROL MOUNTING	10	1
11	33002507	SWITCH, MEMBRANE	10	1
12	33002513	CIRCUIT BOARD ASSEMBLY	10	1
-	912077	LOCKNUT Note: LOCKNUT, WASHER	10	8
13	33001204	STANDOFF, CIRCUIT BOARD	10	4
14	33001978	PANEL, ACCESS (WHT)	10	1
15	Y206081	LOCK FOR ACCESS DOOR Note: LOCK, ACCESS DOOR	10	1
16	213750	LOCKING CAM	10	1
17	33001981	WIRE, GROUND	10	1
-	22003063	SHIELD, PROGRAMMING SWITCH	10	1
18	22003064	SWITCH, SENSOR - EXPORT	10	1
19	912012	SCREW Note: SCREW, PROGRAMMING SWITCH	10	2
20	33001982	BRACKET, SWITCH MOUNTING	10	1
-	33002004	CLIP, FASTENER	10	2
21	33001980	CLIP, ACCESS PANEL Note: FASTENER, ACCESS PANEL	10	2
22	215506	SCREW, TORX Note: SCREW, ACCESS PANEL (TORX)	10	7
23	22003047	FILTER, POWER LINE	10	1
-	22003050	WIRE, GROUND	10	1
24	22003048	BRACKET, LINE FILTER	10	1
25	22003049	NUT (8MM)	10	1
- N	33002045	NUT, SECURITY	10	4
-	33002060	BRACKET, SECURITY	10	1
-	22001995	SCREW Note: SCREW, SECURITY	10	2
-	33002512	HARNESS, WIRE (DRYER)	10	1

*Color Code (-)=Not Shown #=Series, Serial Prefix or Run No., N=Not Available

Section: CONTROL CENTER (DRYER)

Model: MLG19PDAGW

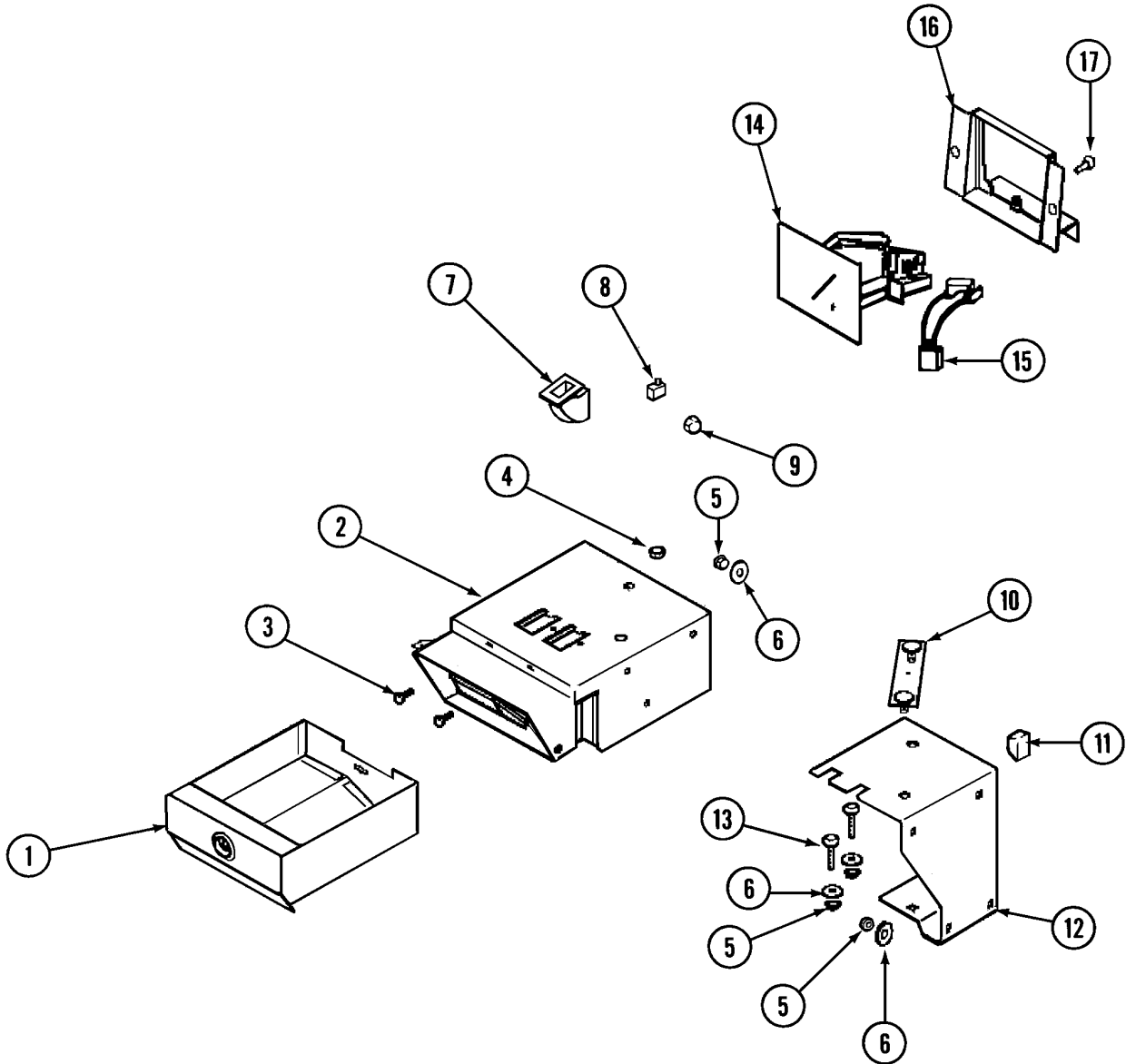

LD11-75

Section: CONTROL CENTER (DRYER)

No.	Part No.	Description	Series	Qty
1	33001983	BOX, COIN (WHT)	10	1
2	33001986	VAULT, COIN (WHT)	10	1
3	33002683	SCREW, PLATED Note: SCREW, COIN DROP BRACKET	10	2
4	Y052740	NUT Note: NUT, COIN VAULT	10	2
5	Y052734	NUT Note: NUT, CARRAGE BOLTS & BRACKET	10	7
6	N 211629	WASHER Note: WASHER, VAULT MOUNTING BRK.	10	7
6	312535	WASHER, ROLLER SHAFT Note: WASHER, VAULT MOUNTING BRK.	10	1
7	314635	COIN CHUTE Note: CHUTE, COIN	10	2
8	22002536	SWITCH, SENSOR Note: SWITCH, VAULT	10	1
-	33001989	RETAINER, WIRE Note: RETAINER, VAULT SWITCH (ATTACHED TO RT SIDE OF CAB)	10	1
9	N 211782	CAGE NUT Note: NUT, CAGE	10	1
10	22001810	STRAP, MOUNTING	10	1
11	33001989	RETAINER, WIRE	10	1
12	33001990	BRACKET, MOUNTING VAULT	10	1
13	33001991	BOLT, CARRIAGE	10	2
14	22001873	DROP ASSY., COIN	10	1
-	216200	BUTTON, RETURN Note: BUTTON, RETURN	10	1
-	33002510	PLATE, COVER	10	1
15	22001965	SWITCH ASSY., OPTIC	10	1
-	314665	SCREW Note: SCREW, OPTIC SWITCH	10	1
16	33001992	BRACKET, COIN DROP MOUNT.(WHT) Note: BRACKET, COIN DROP MOUNT.	10	1
17	212707	SCREW Note: SCREW, COIN DROP MOUNTING BRK.	10	2
-	910181	LOCK WASHER Note: WASHER, LOCK	10	2

*Color Code (-)=Not Shown #=Series, Serial Prefix or Run No., N=Not Available

Section: DOOR (DRYER)

Model: MLG19PDAGW

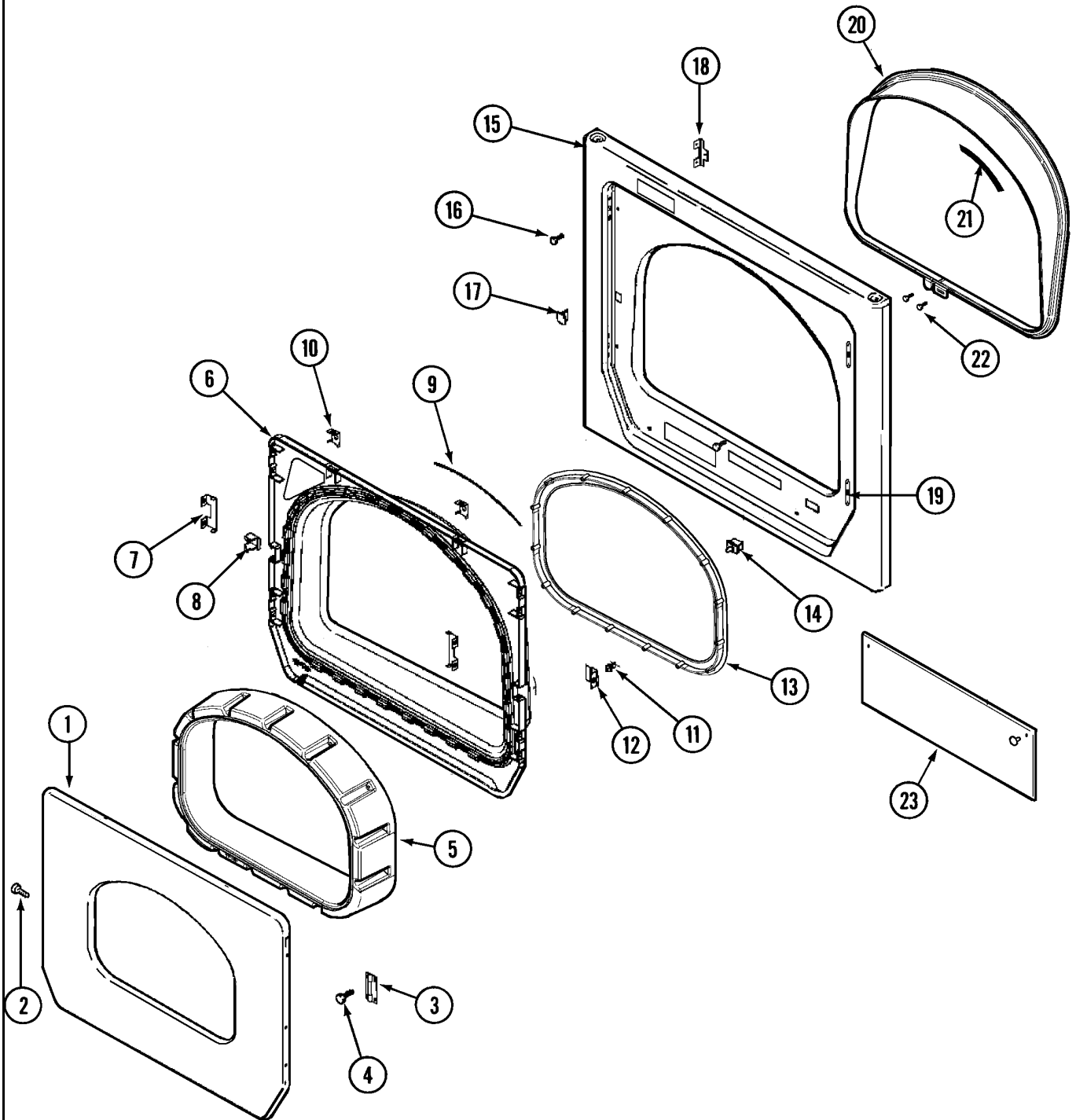

Section: DOOR (DRYER)

No.	Part No.	Description	Series	Qty
1	33002015	DOOR, OUTER (WHT)	10	1
2	22002063	SCREW #8-18AB WAFER HD	10	8
3	33002017	HINGE, DOOR	10	2
4	22002062	SCREW Note: SCREW, HINGE	10	8
5	33002018	TUNNEL (WHT)	10	1
-	22002300	SCREW Note: SCREW, TUNNEL	10	15
6	33002020	DOOR, INNER (WHT)	10	1
7	22002038	CLIP, DOOR (DOUBLE)	10	4
8	33002111	PLUG, INNER DOOR (SHORT)	10	1
9	33002094	SEAL, DOOR	10	1
10	22002039	CLIP, DOOR (SINGLE) Note: CLIP, INNER DOOR	10	2
11	33001761	STRIKE, DOOR (MALE)	10	1
12	33002110	BRACKET, STRIKE (SHORT)	10	1
13	33002022	LENS	10	1
13	33002607	LENS	33	1
14	33002166	SWITCH, DOOR Note: SWITCH, DOOR (UPR)	10	1
-	33001711	NAMEPLATE	10	1
-	33002051	SCREW, TORX Note: SCREW, FRONT PANEL	10	2
15	33002130	PANEL, FRONT (WHT)	10	1
16	33001486	PANEL, FASTENER	10	4
17	33001791	CATCH, DOOR (W/PLUG)	10	1
18	33002025	TWIN SPEEDNUT	10	4
19	33001175	COVER, HINGE HOLE (WHT)	10	2
20	33002026	EXTENSION, TUMBLER FRONT	10	1
21	33001767	SEAL, SHROUD	10	1
22	33001855	SCREW (HEX HEAD) Note: SCREW, TUMBLER FRONT EXTENSION	10	2
23	33002183	SHIELD, CONTROL PANEL	10	1
-	33002048	FASTENER, PUSH	10	2

*Color Code (-)=Not Shown #=Series, Serial Prefix or Run No., N=Not Available

Section: TUMBLER (DRYER)

Model: MLG19PDAGW

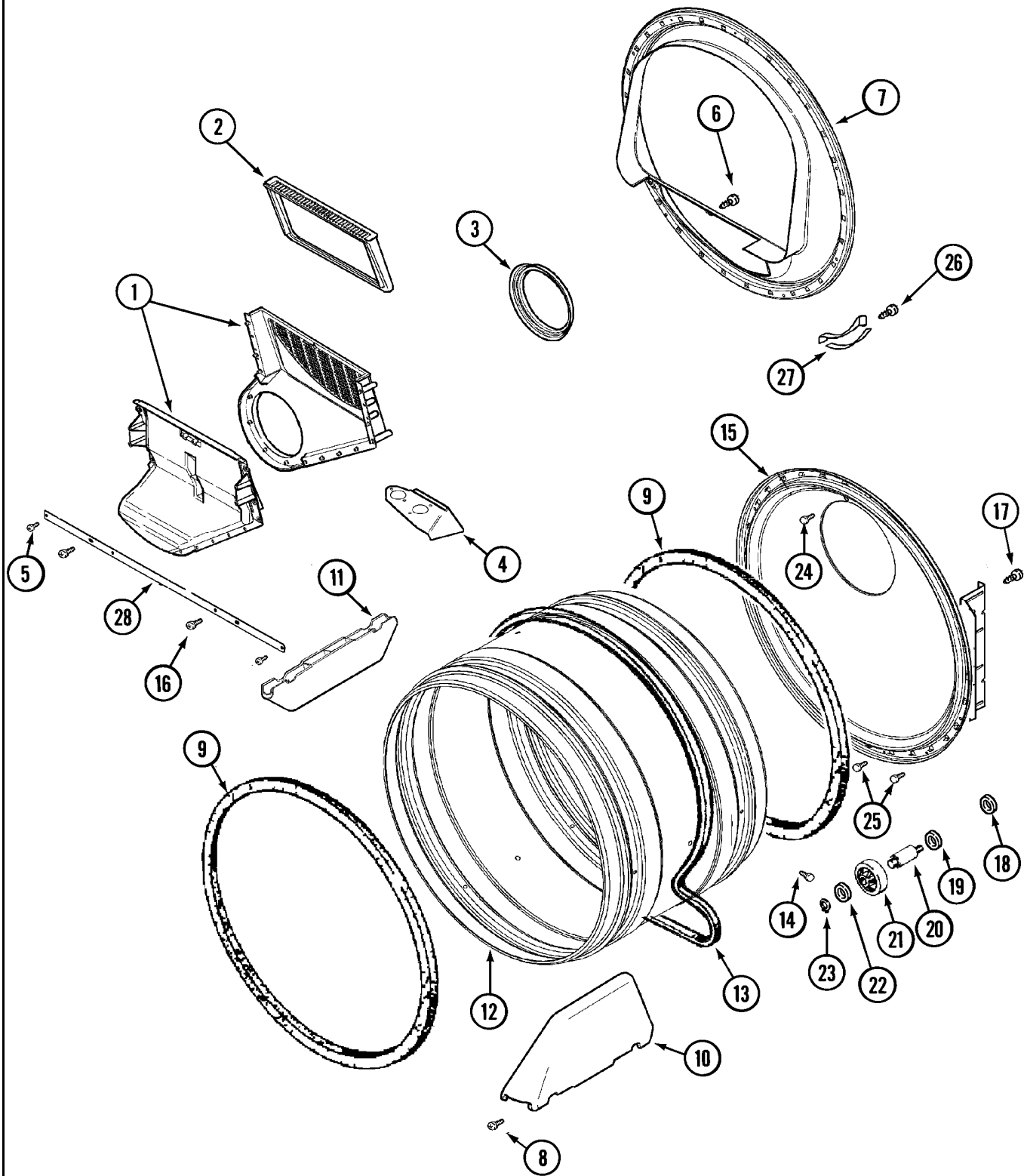

LD13-35

Section: TUMBLER (DRYER)

No.	Part No.	Description	Series	Qty
1	33001799	OUTLET DUCT ASSEMBLY	10	1
2	33001804	FILTER, LINT	10	1
3	33001758	SEAL, BLOWER	10	1
5	22001995	SCREW Note: SCREW, TUMBLER FRONT BRACE	10	2
6 N	312311	SCREW---NA Note: SCREW, OUTLET DUCT	10	1
7	33001802	FRONT, TUMBLER (W/SEAL)	10	1
8	33001855	SCREW (HEX HEAD) Note: SCREW, OUTLET DUCT	10	4
9	33001807	SEAL, TUMBLER	10	2
10	33002032	BAFFLE (TALL)	10	2
11	33001755	BAFFLE (SHORT)	10	1
12	33001794	TUMBLER	10	1
13	33001777	BELT, TUMBLER	10	1
14	33001788	SCREW, BAFFLE	10	6
15	33001801	BACK, TUMBLER (W/SEAL)	10	1
16	33001768	SCREW, SHROUD Note: SCREW, TUMBLER FRONT BRACE	10	2
17	22001995	SCREW Note: SCREW, TUMBLER BACK	10	4
18	33001443	NUT, HEX (ROLLER SHAFT)	10	2
19	313347	WASHER, SPRING (ROLLER SHAFT)	10	2
20	312948	SHAFT, TUMBLER ROLLER	10	2
21	303373	BEARING & ROLLER ASSEMBLY Note: ROLLER (W/BEARING)	10	2
22	312535	WASHER, ROLLER SHAFT	10	2
23	410233	RING, RETAINING	10	2
24	210932	SCREW, #8 X 9/16 CTSK Note: SCREW, INLET DUCT	10	1
25	22001996	SCREW Note: SCREW, INLET DUCT	10	2
26	210720	RIVET	10	4
27	306508	TUMBLER BEARING KIT	10	2
28	33002039	BRACE, TUMBLER FRONT	10	1

*Color Code (-)=Not Shown #=Series, Serial Prefix or Run No., N=Not Available

Section: GAS VALVE (DRYER)

Model: MLG19PDAGW

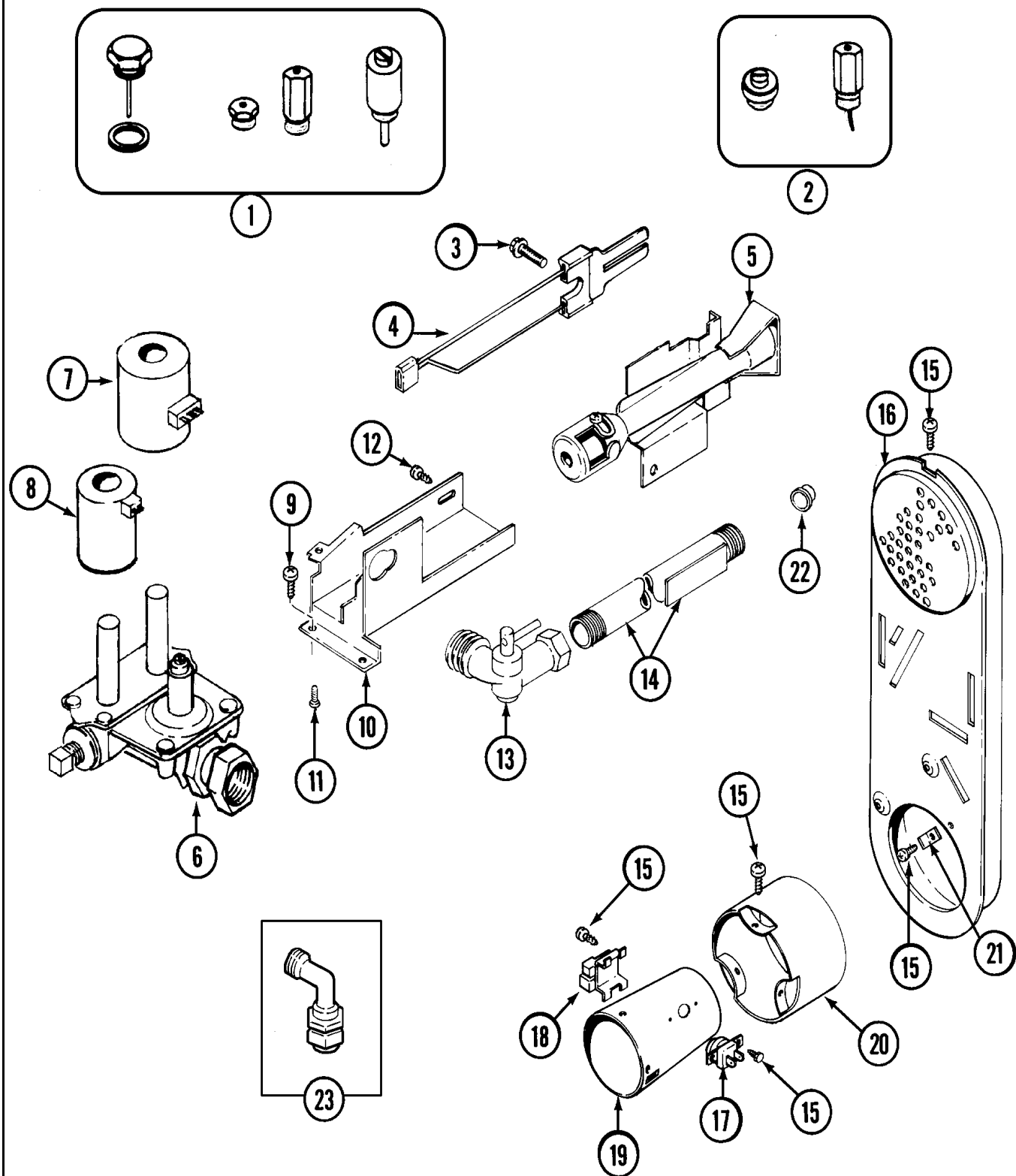

Section: GAS VALVE (DRYER)

No.	Part No.	Description	Series	Qty
1	306195	CONVERSION KIT (NATURAL TO LP)	10	1
2	306204	CONVERSION KIT (LP TO NATURAL)	10	1
3	304971	SCREW Note: SCREW, IGNITER	10	1
4	304970	IGNITER ASSY, GAS VALVE	10	1
5	33001247	BURNER ASSY.	10	1
6	307927	GAS VALVE - 120V-50HZ	10	1
-	33002056	PLUG, HOLE	10	1
7	306106	COIL, HOLDING & BOOSTER	10	1
8	306105	COIL, SECONDARY	10	1
9 N	313561	SCREW----NA Note: SCREW, GAS VALVE	10	2
10 N	33002055	BRACKET, GAS VALVE----NA	10	1
11	314082	SCREW Note: SCREW, GAS VALVE	10	2
12	22001995	SCREW Note: SCREW, GAS VALVE	10	1
13	306086	ANGLE SHUT OFF FOR GAS VALV Note: VALVE, ANGLE GAS	10	1
14	33001735	PIPE & BRACKET ASSY.	10	1
15	211294	SCREW Note: SCREW, DUCT	10	9
16	33001810	DUCT ASSY., INLET (GAS) Note: INLET DUCT ASSEMBLY	10	1
17	305169	THERMOSTAT, HI-LIMIT GAS	10	1
18	303377	SENSOR, RADIANT	10	1
19	33001946	CONE ASSY., COMBUSTION	10	1
20 N	304953	EXTENSION F/COMBUSTION CONE	10	1
21	312890	RETAINER, HEATER CHAMBER	10	1
22	33001693	CAP, GAS PIPE	10	1
23	33002236	ANGLE CONNECTOR ASSY.	10	1

*Color Code (-)=Not Shown #=Series, Serial Prefix or Run No., N=Not Available

Section: MOTOR DRIVE (DRYER)

Model: MLG19PDAGW

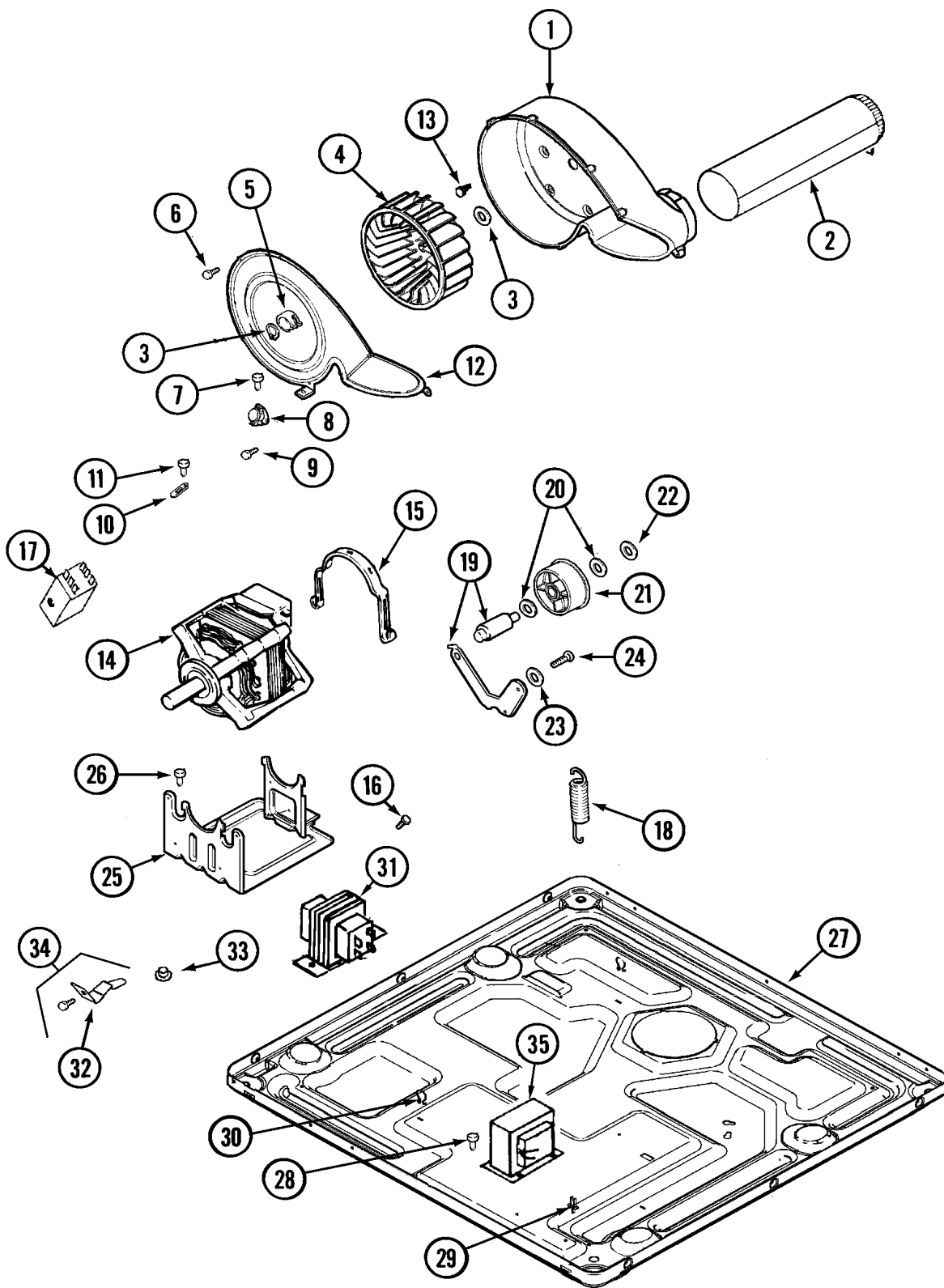

Section: MOTOR DRIVE (DRYER)

No.	Part No.	Description	Series	Qty
1	33001789	HOUSING, BLOWER	10	1
-	22001995	SCREW Note: SCREW, EXHAUST DUCT ASSEMBLY	10	1
2	33002185	DUCT ASSY., EXHAUST	10	1
3	410233	RING, RETAINING	10	2
4	33001790	WHEEL, BLOWER	10	1
5	312967	CLAMP, BLOWER HOUSING	10	1
6	33001855	SCREW (HEX HEAD) Note: SCREW, HOUSING COVER	10	8
7	N 313561	SCREW----NA Note: SCREW, HOUSING COVER	10	1
8	33303391	THERMOSTAT, CYCLING Note: THERMOSTAT, CYCLING (155 DEG)	10	1
8	303392	CYCLING THERMOSTAT 140 DEG. Note: THERMOSTAT, CYCLING (140 DEG)	10	1
9	22001996	SCREW Note: SCREW, THERMOSTAT	10	4
10	33001762	FUSE, THERMAL (W' BRACKET)	10	1
11	22001996	SCREW Note: SCREW, THERMAL CUT-OFF	10	1
12	33001796	COVER, BLOWER HOUSING	10	1
13	314818	SCREW Note: SCREW, BLOWER HOUSING	10	4
14	33001945	MOTOR	10	1
15	Y015825	CLIP, MOTOR	10	2
16	910343	SCREW, GROUND WIRE	10	1
17	33001854	SWITCH, MOTOR	10	1
18	33001754	SPRING, IDLER	10	1
19	33001840	IDLER ARM & SHAFT ASSY.	10	1
20	312527	WASHER, IDLER SHAFT (QTY-1)	10	2
21	33001783	BEARING, IDLER ASSEMBLY	10	1
22	312958	RETAINING RING, IDLER SHAFT	10	1
23	315772	SLEEVE, IDLER ARM	10	1
24	Y014874	SCREW	10	1
25	33001752	SUPPORT, MOTOR	10	1
26	N 313561	SCREW----NA Note: SCREW, MOTOR SUPPORT	10	2
-	33002050	PROTECTOR, HARNESS	10	2
27	33002467	BASE (UPR)	38	1
27	33002623	BASE, (UPR)	36	1
27	33002041	BASE (UPR)	10	1
-	33002049	STRIP, GROMMET	10	2
-	314568	SCREW-GAS VALVE TO BRACKET Note: SCREW, HARNESS PROTECTOR	10	2
28	22001078	SCREW Note: SCREW, TRANSFORMER	10	2
29	315471	RETAINER, WIRE	10	2
30	410490	SPRING, WIRE HARNESS	10	2
-	315218	SHIELD, XFMER Note: SHIELD, TRANSFORMER	10	1
31	33002508	TRANSFORMER	10	1
-	22001995	SCREW Note: SCREW, BRACKET	10	2
32	33002042	BRACKET (LT)	10	1
32	33002043	BRACKET (RT) Note: (RT)	10	1
33	33002044	GUIDE	10	2
34	N 12001551	BRACKET/SCREW PACKAGE Note: (INCL RT/LT BRKT & SCREWS)	10	1
35	22002476	TRANSFORMER	10	1

*Color Code (-)=Not Shown #=Series, Serial Prefix or Run No., N=Not Available

Section: CABINET-FRONT (WASHER)

Model: MLG19PDAGW

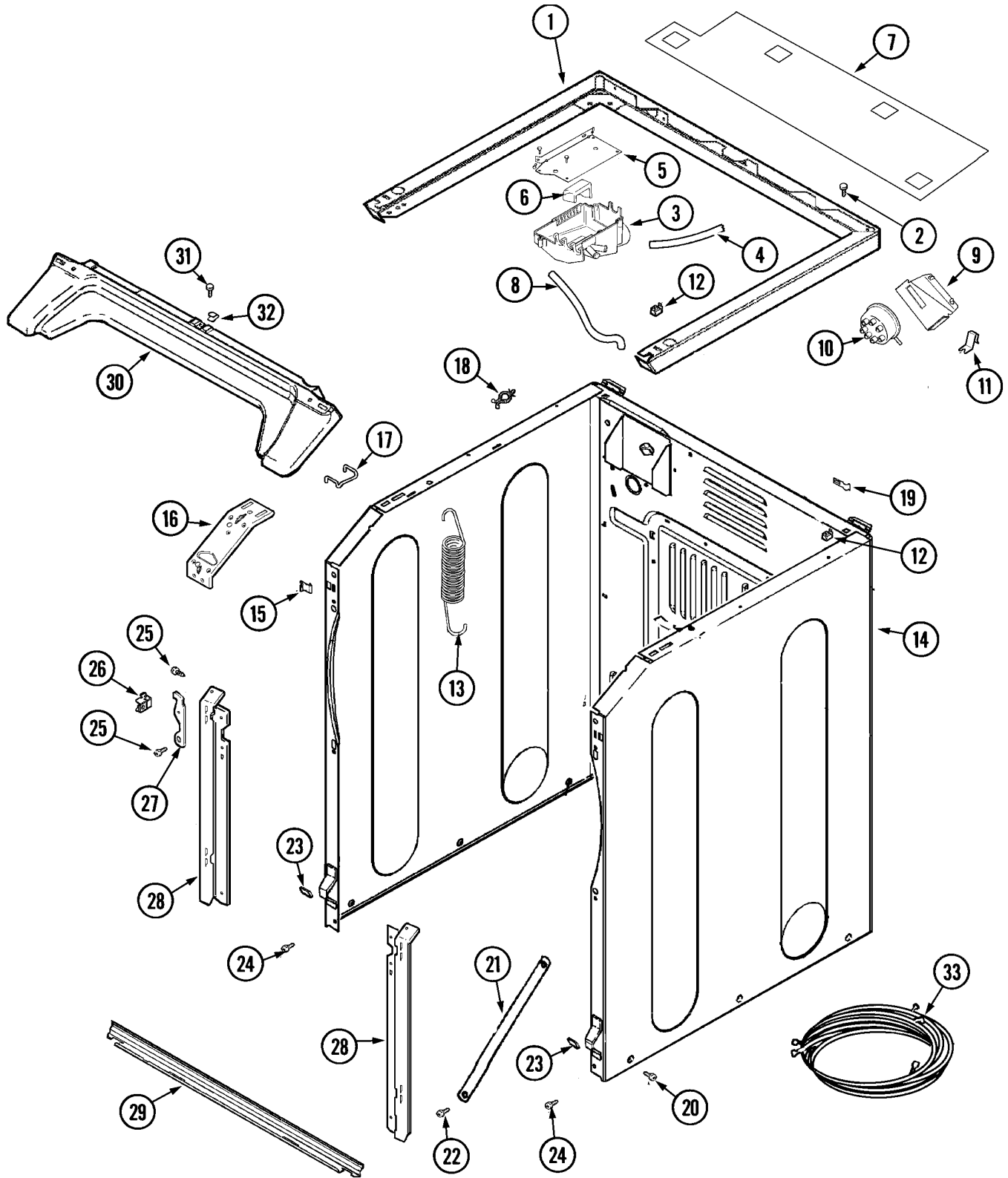

LW12-16

Section: CABINET-FRONT (WASHER)

No.	Part No.	Description	Series	Qty
1	33002187	SUPPORT WELD ASSY, WHITE	10	1
2	22001883	SCREW Note: SCREW, SUPPORT	10	4
3	22002439	VENT, TUB ----SUB Note: VENT, TUB	10	1
-	33001855	SCREW (HEX HEAD) Note: SCREW, VENT TUB	10	4
4	22002464	HOSE Note: HOSE, VENT	10	1
5	33002189	BRACKET, VENT MOUNTING	10	1
-	33002190	SCREW (#10-3/8") Note: SCREW, BRACKET	10	1
6	22002440	DEFLECTOR, VENT	10	1
-	33002192	CLIP, SHIELD	10	4
7	33002191	WIRE SHIELD	10	1
8	33002193	SHOWER HOSE	10	1
-	205161	CLAMP - 15/16" Note: CLAMP, HOSE	10	2
-	310376	CLIP, WIRE HARNESS	10	1
9	33002188	SUPPORT, PRESSURE SWITCH	10	1
10	22002048	SWITCH, PRESSURE	10	1
11	22002244	CLIP, GROUNDING	10	1
-	22002006	CLIP Note: CLIP, WIRE HARNESS	10	1
12	33002194	NUT, SPEED	10	2
13	22002100	SPRING Note: SPRING	10	2
-	22002179	TIE, CABLE	10	2
14 N	22003582	CABINET, ASSY. (WHT-AS PK)	36	1
14	22002548	CABINET ASSY. (WHT)	10	1
15	22002049	CLIP Note: CLIP, FRONT PANEL	10	2
16	33002095	BRACKET, CORNER (LT) Note: BRACKET, CORNER (LT)	10	1
16	33002010	BRACKET, CORNER (RT)	10	1
-	22003638	SHROUD SUPPORT ASSEMBLY	37	1
17	22002297	SUPPORT, SPRING	10	2
18	315471	RETAINER, WIRE	10	2
19	22002178	BRACKET, WATER SWITCH	10	1
-	22001996	SCREW Note: SCREW, BRACKET	10	1
20	213007	SCREW, CABINET	10	6
20	22003409	SCREW----NA Note: SCREW, CABINET (TRUSS)	36	6
21	22002259	BRACE, CROSS	10	2
22	33002190	SCREW (#10-3/8") Note: SCREW, CROSS BRACE	10	2
23	22002013	STOP, SHIPPING	10	2
24	33002190	SCREW (#10-3/8") Note: SCREW, CABINET	10	2
25	22001995	SCREW Note: SCREW, SHROUD SUPPORT	10	8
26	22002001	SUPPORT, HINGE	10	4
-	33002037	FASTENER, ACCESS COVER HOOK	10	2
27	22002991	KIT, ACCESS COVER HOOK	10	1
28	22002035	BRACKET, SHROUD SUPPORT (LT) Note: BRACKET, SHROUD SUPPORT (LT)	10	1
28	22002034	BRACKET, SHROUD SUPPORT (RT)	10	1
29	22001993	BRIDGE, SHROUD SUPPORT	10	1
29	22003638	SHROUD SUPPORT ASSEMBLY	69	1
30	33002011	COVER, ACCESS (WHT)	10	1
31	22001995	SCREW Note: SCREW, ACCESS COVER	10	1
32	33002013	FASTENER CLIP, ACCESS COVER Note: FASTENER, ACCESS COVER	10	1
-	22003819	WIRE HARNESS, LOWER COMMERCIAL	77	1
-	22003820	WIRE HARNESS / HH / UNBALANCE	77	1
33	22003068	WIRE HARNESS, MAIN (LWR)	10	1
-	22002006	CLIP Note: CLIP, HARNESS TO CAB. FLANGE	77	1
-	33001989	RETAINER, WIRE Note: RETAINER, WIRE HARNESS	10	2

*Color Code (-)=Not Shown #=Series, Serial Prefix or Run No., N=Not Available

Section: DOOR SHROUD & DOOR LATCH ASSEMBLY (WASH)

Model: MLG19PDAGW

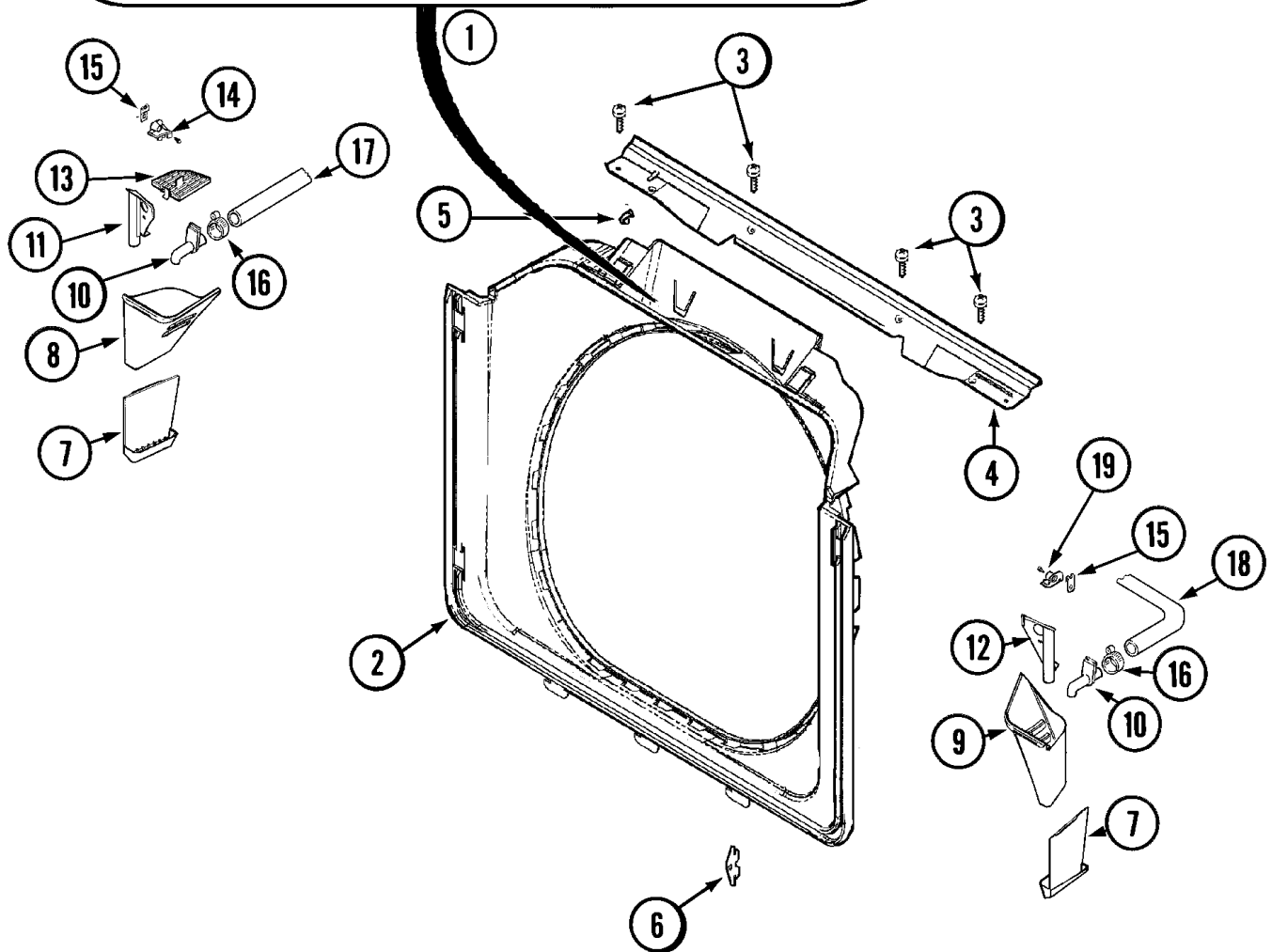
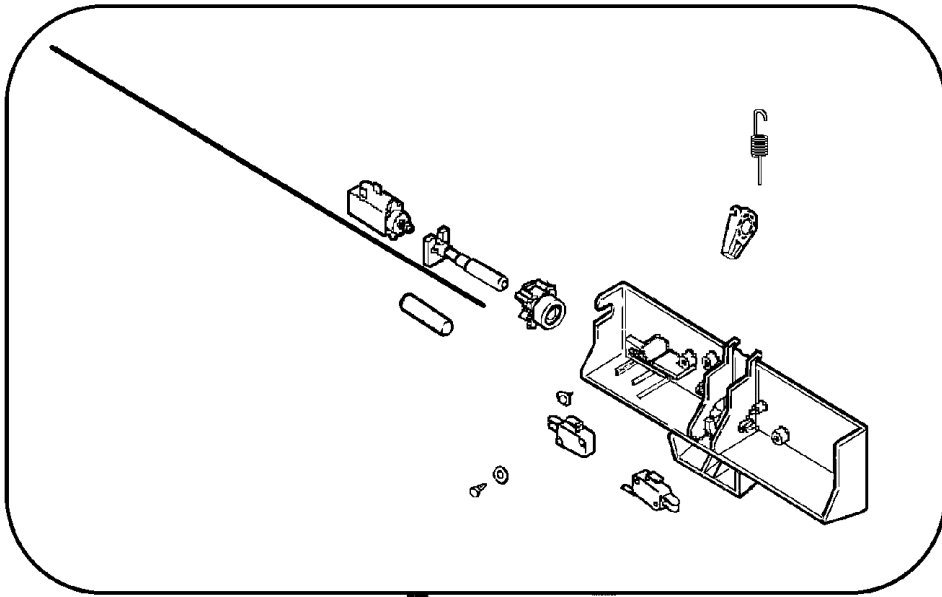

LW18-1

Section: DOOR SHROUD & DOOR LATCH ASSEMBLY

No.	Part No.	Description	Series	Qty
1	N 22002494	MECHANISM, DOOR LATCH	10	1
-	22002957	COVER, LATCH ASSEMBLY (LWR)	10	1
2	22002506	SHROUD/DISPENSER HOSE ASSY. Note: SHROUD & DISPENSER HOSE (WHT)	10	1
-	22003653	RETAINER, DISPENSER HOSE	37	2
3	22001995	SCREW Note: SCREW, DOOR LOCK SUPPORT	10	6
4	33002202	SUPPORT, DOOR LOCK	10	1
-	33002203	CLIP, HOSE	10	2
-	22003908	VAPOR BARRIER	53	1
5	22002014	CLIP Note: CLIP, WIRE HARNESS	10	1
-	33001787	SCREW, HINGE	44	2
6	22002095	COVER, HINGE (WHT)	10	2
-	33001764	COVER, HINGE HOLE (WHT)	44	2
7	33002195	GRATE, OVERFLOW (LT)	10	1
7	33002196	GRATE, OVERFLOW (RT)	10	1
8	33002197	CUP, BLEACH DISPENSER	10	1
9	33002198	CUP, FABRIC SOFTENER DISPENSER	10	1
10	33002199	SPOUT, DISPENSER FILL	10	2
11	33002200	CAP, BLEACH DISPENSER	10	1
12	33002201	CAP, FABRIC SOFTENER	10	1
13	33002204	SCREEN, BLEACH CUP	10	1
-	22002230	SCREW, DISPENSER	10	1
14	33002205	RETAINER, BLEACH CUP	10	1
15	33002206	FASTENER, J TYPE	10	2
16	205161	CLAMP - 15/16"	10	2
17	33002207	HOSE, BLEACH	10	1
-	22003653	RETAINER, DISPENSER HOSE	69	1
18	33002208	HOSE, FABRIC SOFTENER	10	1
-	22003653	RETAINER, DISPENSER HOSE	69	1
19	33002209	RETAINER, FABRIC SOFTENER	10	1
-	22002230	SCREW, DISPENSER	10	1
-	22002484	LABEL, BLEACH	10	1
-	22002487	LABEL, ADD DETERGENT	10	1
-	22002486	LABEL, LOADING INSTRUCTIONS	10	1
-	22002485	LABEL, FABRIC SOFTENER	10	1

*Color Code (-)=Not Shown #=Series, Serial Prefix or Run No., N=Not Available

Section: DOOR & FRONT PANEL (WASHER)

Model: MLG19PDAGW

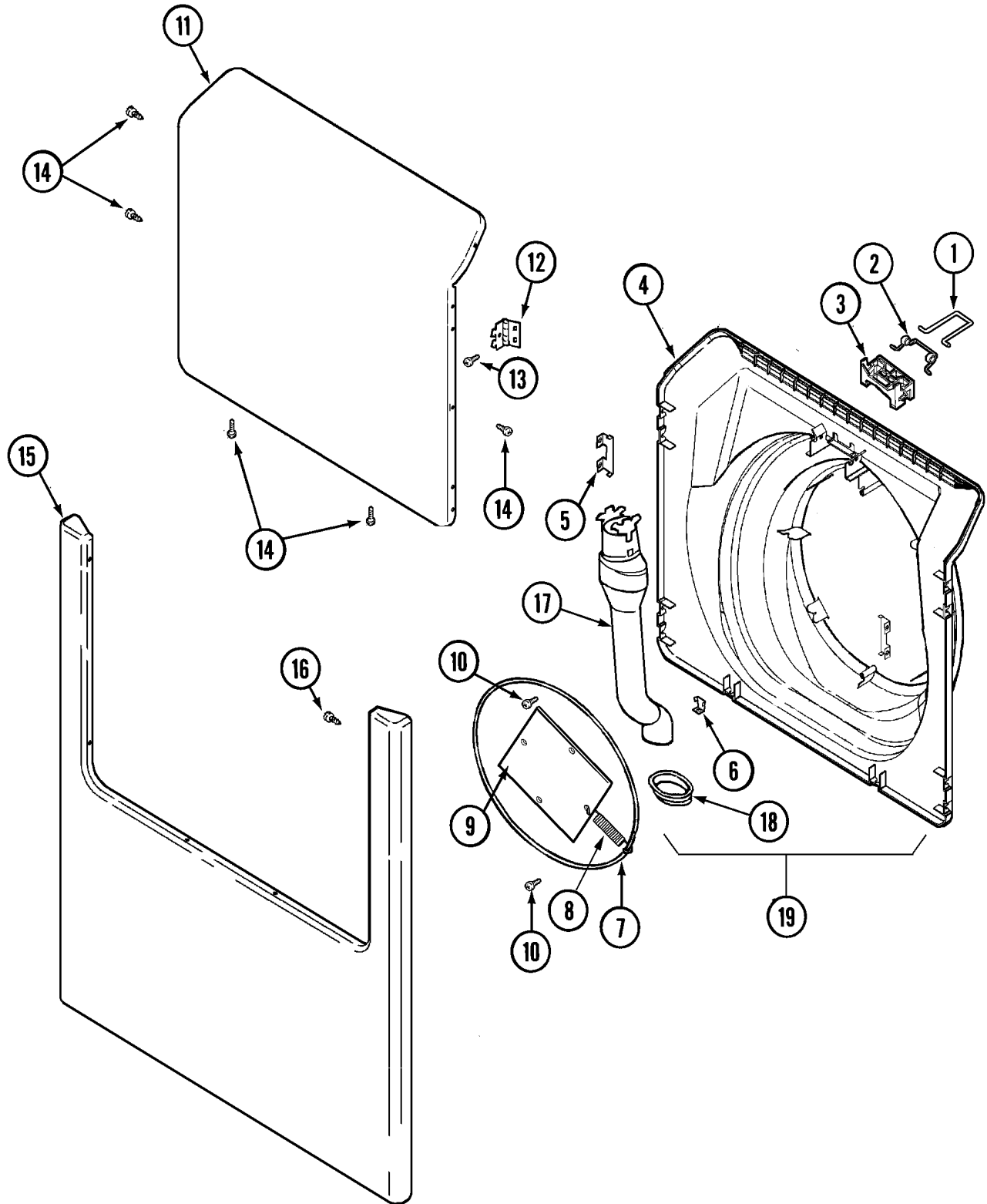

LW18-8

Section: DOOR & FRONT PANEL (WASHER)

No.	Part No.	Description	Series	Qty
1	22002002	HOOP, LOCK	10	1
2	22002003	SPRING, LATCH	10	1
3	22002168	SUPPORT, LOCK HOOP	10	1
4	22002539	DOOR, INNER (W/VENT-WHT)	10	1
-	22003800	INNER DOOR/VENTED (ASPK-WHT)	46	1
4	22003076	DOOR, INNER (WHT)	23	1
5	22002038	CLIP, DOOR (DOUBLE)	10	4
6	22002039	CLIP, DOOR (SINGLE)	10	2
7	W10124350	NOT REQUIRED PART OR SEE NOTE Note: NOT REQUIRED	34	0
7	22002104	WIREFRAME Note: FRAME, WIRE	10	1
8	W10124350	NOT REQUIRED PART OR SEE NOTE	34	0
8	22002356	SPRING, PLATE Note: SPRING, PLATE	10	4
9	W10124350	NOT REQUIRED PART OR SEE NOTE	34	0
9	22002094	PLATE	10	1
10	W10124350	NOT REQUIRED PART OR SEE NOTE	34	0
11	22001979	DOOR, OUTER (WHT-W/DAMPER)	10	1
12	N 22004360	Hinge w/no offset	10	2
13	22002062	SCREW Note: SCREW, HINGE	10	4
14	22002063	SCREW #8-18AB WAFER HD	10	6
15	22002241	PANEL, FRONT (WHT)	10	1
16	22002243	SCREW Note: SCREW, FRONT PANEL & HINGE	10	4
-	22002244	CLIP, GROUNDING	10	1
17	22002990	VENT TUBE ASSEMBLY	23	1
18	22003075	GROMMET, VENT TUBE	23	1
19	22003083	LINER, DOOR ASSY W/VENT (WHT)	23	1

*Color Code (-)=Not Shown #=Series, Serial Prefix or Run No., N=Not Available

Section: CABINET-REAR (WASHER)

Model: MLG19PDAGW

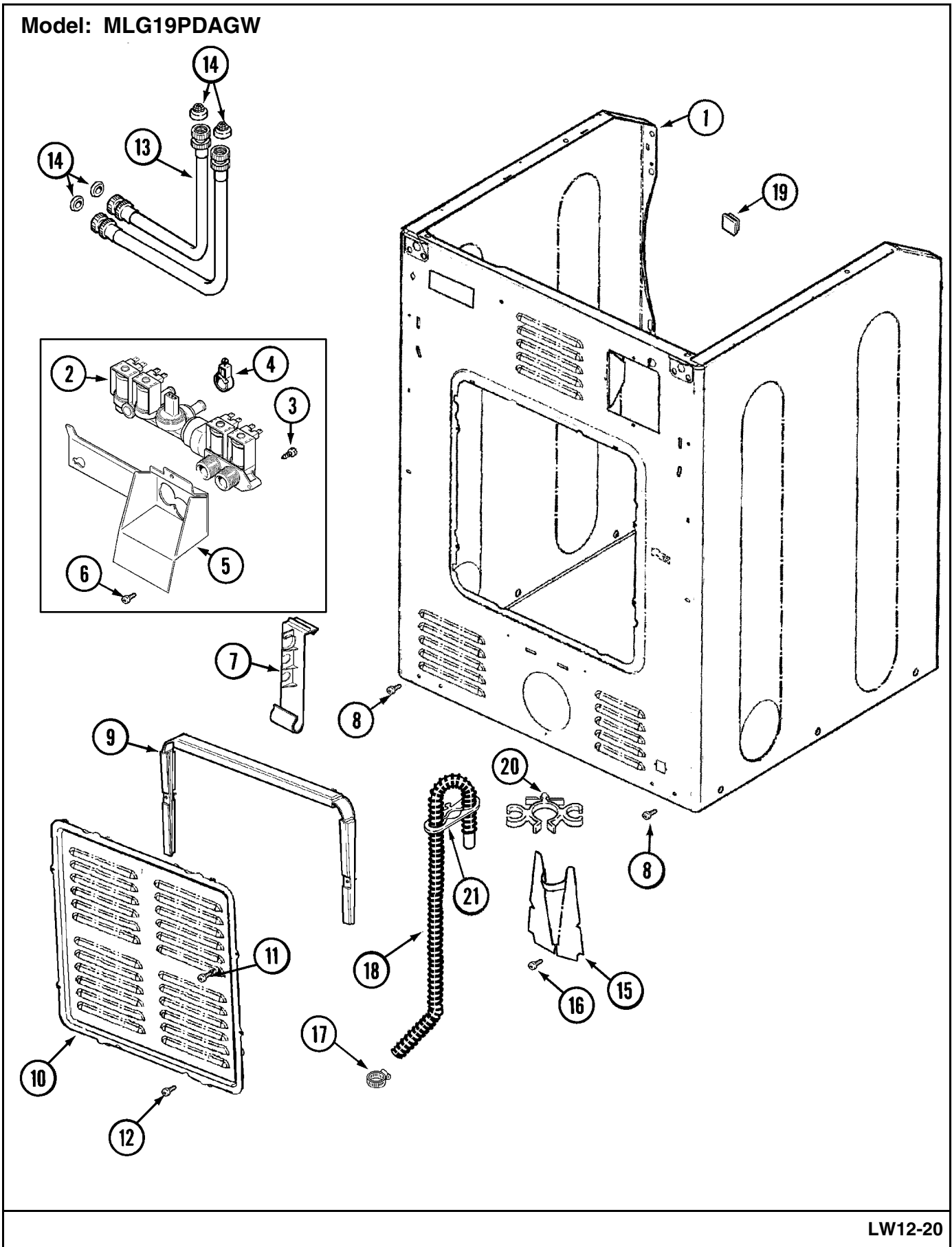

LW12-20

Section: CABINET-REAR (WASHER)

No.	Part No.	Description	Series	Qty
1	22002548	CABINET ASSY. (WHT) Note: (CABINET ONLY)	10	1
-	22003367	HINGE, PLASTIC	36	2
-	22001995	SCREW Note: SCREW, HINGE	36	2
1 N	22003582	CABINET, ASSY. (WHT-AS PK)	36	1
2	22002903	VALVE, WATER	10	1
3	22002436	SCREW Note: SCREW, WATER VALVE	10	1
4	205161	CLAMP - 15/16" Note: CLAMP, WATER VALVE	10	3
5	33002212	BRACKET, WATER VALVE	10	1
6	22001996	SCREW Note: SCREW, WATER VALVE BRACKET	10	2
7	33002213	RACK, HOSE	10	1
8	22001995	SCREW Note: SCREW, CABINET	10	2
9	22002022	SPACER, ACCESS PANEL	10	1
10	22002092	PANEL, ACCESS	10	1
11	22002295	SCREW Note: SCREW, ACCESS PANEL SPACER	10	2
12	22001996	SCREW Note: SCREW, ACCESS PANEL	10	2
13	208100	HOSE, INLET ASSY	10	2
14	Y013783	GASKET, INLET HOSE Note: WASHER, INLET HOSE	10	4
15	22002093	COVER, DRAIN HOSE	10	1
16	22001995	SCREW Note: SCREW, DRAIN HOSE COVER	10	1
17	22001984	CLAMP, DRAIN HOSE	10	2
-	22002893	TIE, CABLE	10	1
18	22002891	HOSE, DRAIN	10	1
-	12001659	DRAIN HOSE REPLACEMENT(NEPTUN)	10	1
19 N	215950	PLUG, HOLE	10	1
20	22002932	CLIP, DRAIN HOSE	10	1
21	22002892	RETAINER, DRAIN HOSE	10	1

*Color Code (-)=Not Shown #=Series, Serial Prefix or Run No., N=Not Available

Section: OUTER TUB

Model: MLG19PDAGW

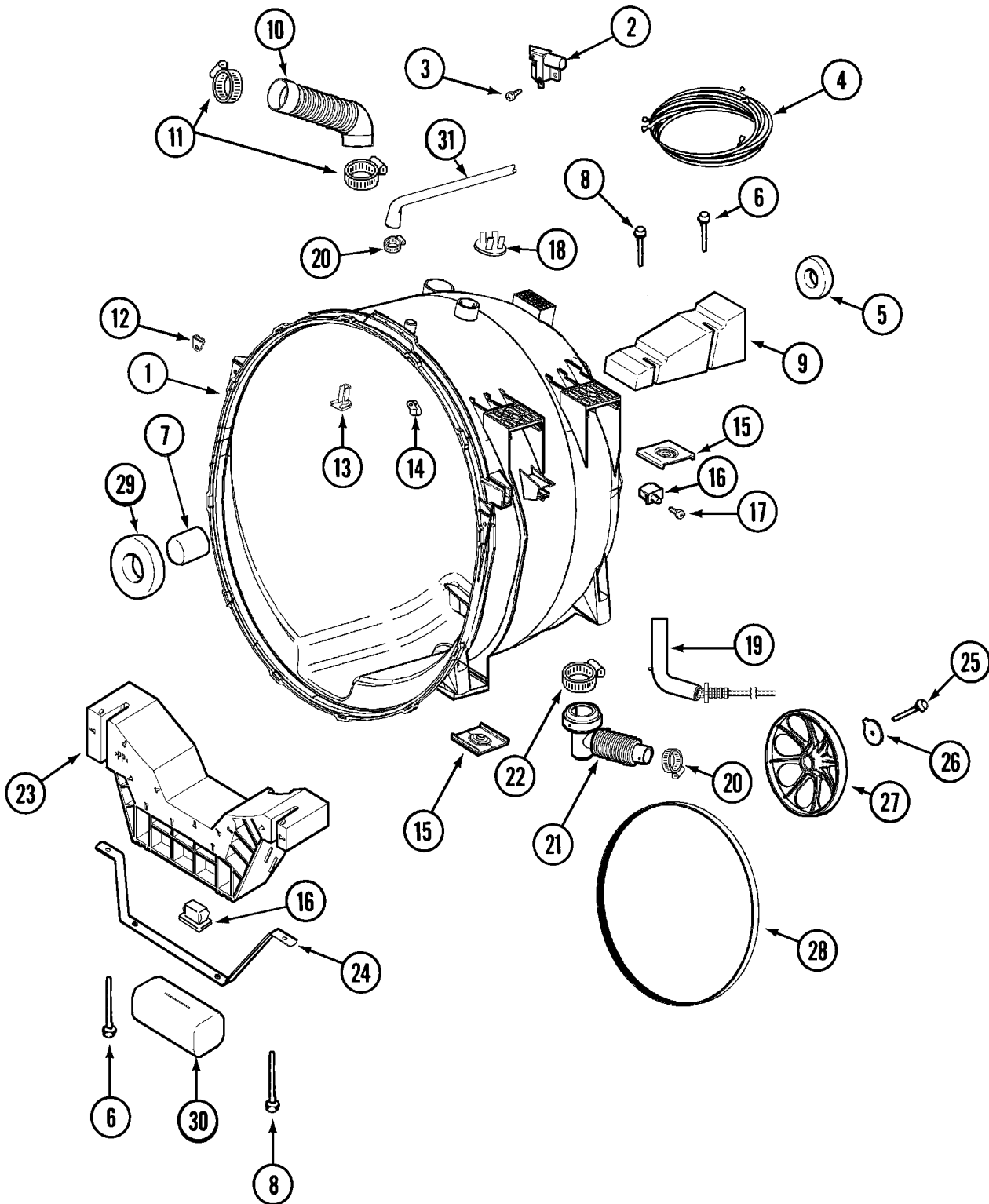

CW17-51

Section: OUTER TUB

No.	Part No.	Description	Series	Qty
-	22002006	CLIP Note: CLIP, UNBALANCE SWITCH	10	2
1	22002154	TUB ASSY. (OUTER) Note: OUTER TUB ASSEMBLY	10	1
-	22003302	SWITCH, INTERNAL UNBALANCE	55	1
2	22002045	SWITCH, INERTIAL - UNBALANCE Note: SWITCH, UNBALANCE	10	1
3	22002300	SCREW Note: SCREW, INERTIAL SWITCH	10	2
4	33002216	WIRE HARNESS, UNBALANCE /COMM	10	1
5	22003441	BEARING, REAR	28	1
5	200720	BALL BEARING, RADIAL	10	1
6	22003615	BOLT, DOUBLE SEMS 5-3/8	10	2
7	22002935	SPACER, BEARING	10	1
8	22003616	BOLT, DOUBLE SEMS 3-3/8	10	2
9	22002102	WEIGHT, COUNTER BALANCE	10	1
10	22002083	HOSE, INJECTOR	10	1
11	22002052	CLAMP, INJECTOR HOSE	10	2
12	22002103	CLIP, U Note: CLIP, U	10	2
13	22002959	DEFLECTOR, WATER	23	1
13	22002004	DEFLECTOR, WATER	10	1
14	22002006	CLIP Note: CLIP, WIRE HARNESS & OUTER TUB	10	2
-	22002061	SCREW	10	1
15	22002065	NUT, COUNTER BALANCE	10	2
16	22002044	SWITCH, TUB DISPLACEMENT	10	2
-	22002044	SWITCH, TUB DISPLACEMENT	55	1
17	22002061	SCREW Note: SCREW, DISPLACEMENT SWITCH	10	1
18	202515	HOSE CLAMP - 1-1/16 INCH Note: CLAMP, HOSE	10	1
19	22002483	HOSE, AIR DOME (SHORT)	10	1
20	22001984	CLAMP, DRAIN HOSE	10	1
21	22002081	HOSE, TUB OUTLET	10	1
22	22002053	CLAMP, SUMP HOSE	10	1
23	22002302	WEIGHT ASSEMBLY (FRT)	10	1
-	22002006	CLIP Note: CLIP, UNBALANCE SWITCH HARNESS(ATTACHED TO FRT WEIGHT ASSY)	10	1
24	22002008	STRAP	10	1
25	22002057	SCREW, SPINNER	10	1
26	22002055	WASHER, SPINNER SHAFT	10	1
-	22003936	WASHER (1 1/4")	54	1
27	22001998	PULLEY, SPINNER	10	1
28	12001435	BELT KIT, DRIVE	10	1
29	22002934	BEARING, FRONT	10	1
30	22002011	CUSHION	10	1

*Color Code (-)=Not Shown #=Series, Serial Prefix or Run No., N=Not Available

Section: SPINNER ASSEMBLY & OUTER TUB COVER(WASH)

Model: MLG19PDAGW

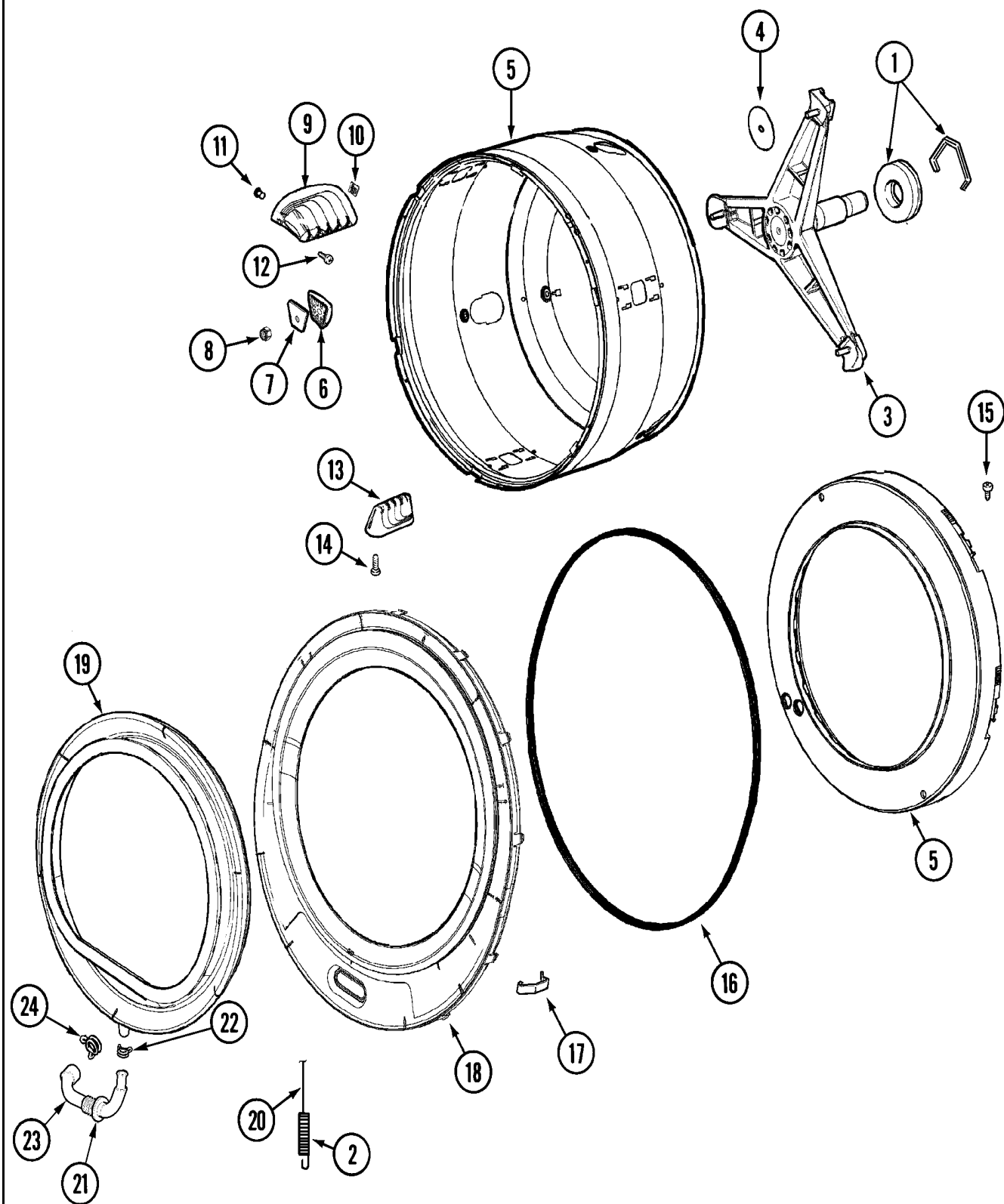

LW13-33

Section: SPINNER ASSEMBLY & OUTER TUB COVER(

No.	Part No.	Description	Series	Qty
1	12001478	LIP SEAL SVC ASSY. Note: LIP SEAL SERVICE ASSEMBLY	10	1
2	22002099	SPRING, TUB	10	1
3	22002897	SUPPORT ASSY., SPINNER	10	1
-	22002123	TUBE, MOLYKOTE	10	1
-	22003925	SPINNER SUPPORT ASSY AS PACK	54	1
4	22002023	WASHER, PLASTIC	10	3
5	22002115	SPINNER ASSY. (W/BALANCE RING)	10	1
6	22002021	WASHER, PROFILE	10	3
7	22002020	WASHER, SPINNER SUPPORT	10	3
8	22002122	NUT, SPINNER ATTACHMENT	10	3
9	22001985	BAFFLE, DRIP (REAR)	10	3
10	22002009	GROMMET, BAFFLE (REAR)	10	3
11	22001999	GROMMET, BAFFLE (FRT)	10	3
12	22002325	SCREW Note: SCREW, BAFFLE (REAR)	10	6
13	22001986	BAFFLE, DRIP (FRONT)	10	3
14	22002059	SCREW Note: SCREW, BAFFLE (FRONT)	10	6
15 N	22002028	SCREW, BALANCE RING Note: PART NEVER USED IN PRODUCTION	10	1
16	22002077	SEAL, TUB COVER	10	1
17	22002050	CLIP, TUB TO COVER	10	13
18	22003212	COVER, TUB (W/SEAL) (ASP)	23	1
18	33002217	COVER, TUB (W/SEAL)	10	1
18	22002979	COVER, OUTER TUB (ASP)	14	1
-	22003257	CAP, SUMP	77	1
-	22003263	SCREW	77	1
19	12001772	KIT, DOOR BOOT W/DRAIN	23	1
19	22001978	BOOT, DOOR	10	1
20	22002327	BOOT CABLE CLAMP	10	1
21	22003074	GUARD, HOSE	23	1
22	22003072	CLAMP, HOSE DOUBLE WIRE	23	1
23	22003071	DOOR BOOT DRAIN HOSE	23	1
24	22003073	CLAMP, HOSE DOUBLE WIRE	23	1

*Color Code (-)=Not Shown #=Series, Serial Prefix or Run No., N=Not Available

Section: BASE

Model: MLG19PDAGW

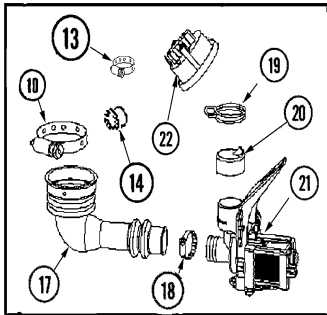
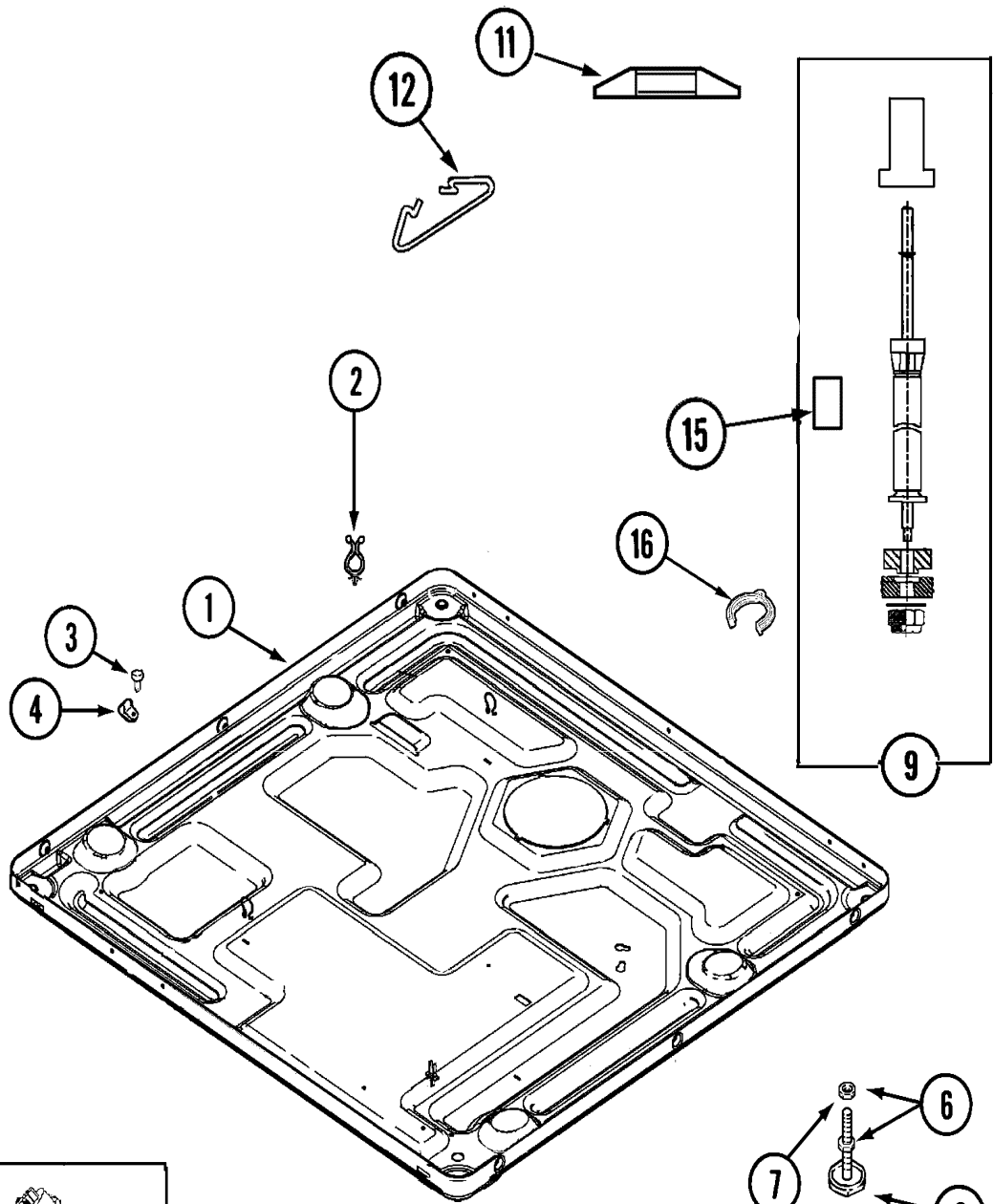

SERIES 45
SERIES 51 & LATER

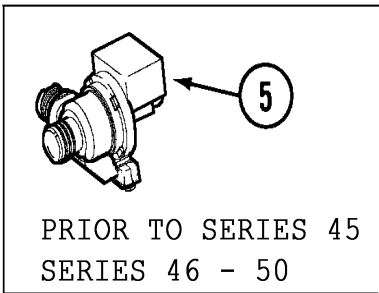

PRIOR TO SERIES 45
SERIES 46 - 50

Section: BASE

No.	Part No.	Description	Series	Qty
1	22003580	BASE, ASSEMBLY	36	1
-	213007	SCREW, CABINET Note: SCREW, CABINET TO BASE	38	1
1	22002240	BASE	10	1
1	22003605	BASE WELD ASSEMBLY	38	1
2	33001989	RETAINER, WIRE	10	1
2	315471	RETAINER, WIRE Note: RETAINER, WIRE	10	2
3	N 313561	SCREW----NA Note: SCREW, WIRE HARNESS CLIP	10	1
4	22002014	CLIP Note: CLIP, WIRE HARNESS	10	1
5	22003709	PUMP,DRAIN (50HZ)	45	1
5	22002809	PUMP (50HZ)	10	1
6	22001915	ADJUSTABLE LEG & NUT	10	4
7	Y052740	NUT Note: NUT, LEG	10	4
8	210684	FOOT, RUBBER	10	4
9	22001988	STRUT ASSY-REAR	10	1
10	22002053	CLAMP, SUMP HOSE	45	1
11	33002222	DEFLECTOR, WATER Note: (ON LEFT STRUT ONLY)	10	1
13	22003295	CLAMP, HOSE DOUBLE WIRE	45	1
14	22003261	PLUG, OUTER TUB	45	1
15	33002224	SLEEVING, BRAIDED	10	1
16	22002853	CLAMP, HOSE	10	1
17	22003262	HOSE, TUB TO PUMP	45	1
18	22001984	CLAMP, DRAIN HOSE	45	1
19	22002853	CLAMP, HOSE	45	1
20	22003268	CAP, RUBBER	45	4
-	N 22003265	BAG, PLASTIC W/DRAWSTRING	45	1
21	22003709	PUMP,DRAIN (50HZ)	45	1
22	22003728	SWITCH, PRESSURE	45	1

*Color Code (-)=Not Shown #=Series, Serial Prefix or Run No., N=Not Available

Section: CABINET-FRONT (DRYER)

Model: MLG19PDAGW

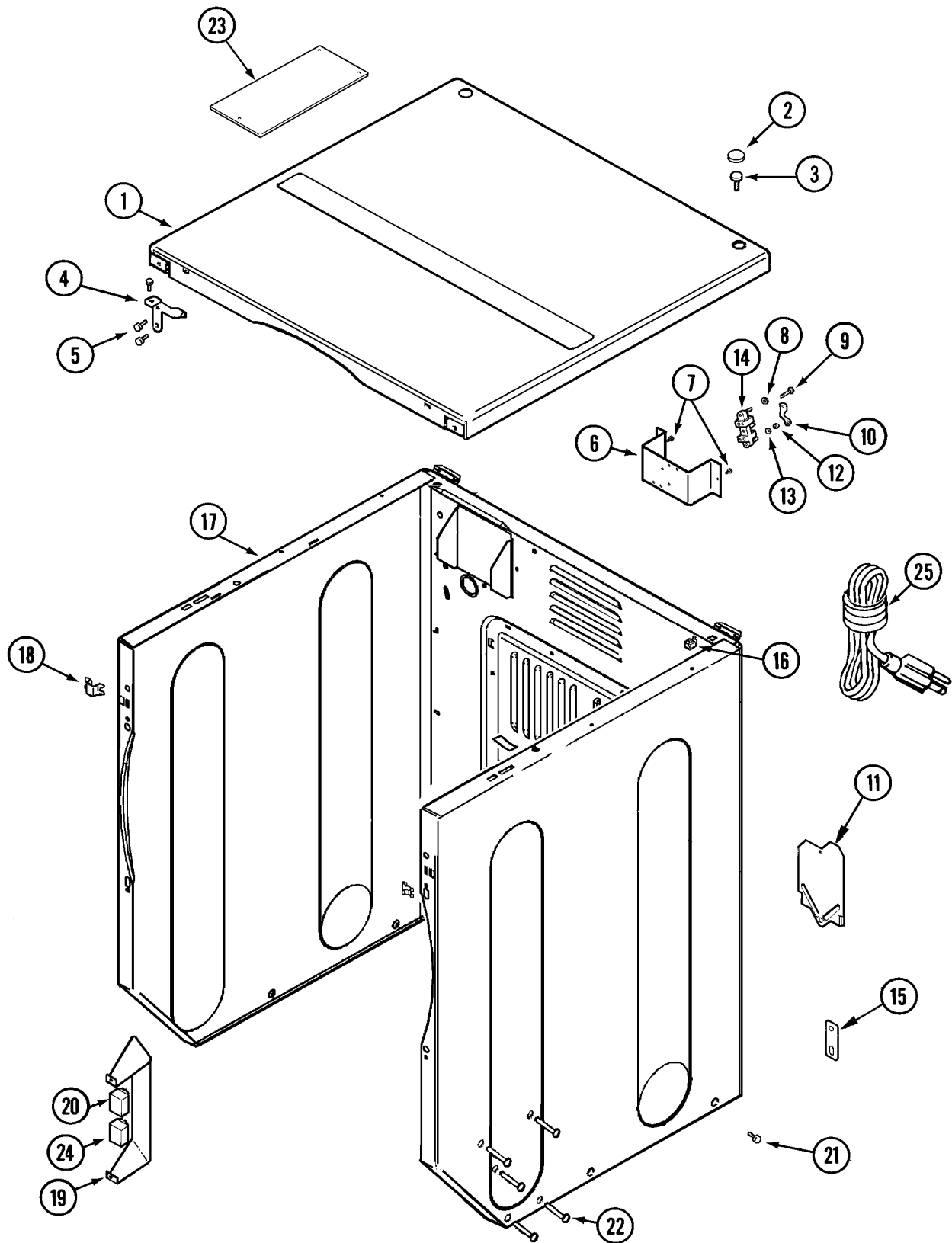

LD12-79

Section: CABINET-FRONT (DRYER)

No.	Part No.	Description	Series	Qty
1	33001995	COVER, TOP (WHT)	10	1
2	33001997	PLUG, HOLE	10	2
3	22001883	SCREW Note: SCREW, TOP COVER	10	2
4	33001999	BRACKET, TOP COVER (RT) Note: BRACKET, TOP COVER (RT)	10	1
4	33001998	BRACKET, TOP COVER (LT)	10	1
5	22001995	SCREW Note: SCREW, TOP COVER BRACKET	10	6
6	N 33001826	BRACKET, TERMINAL BLOCK----NA	10	1
7	22001995	SCREW Note: SCREW, TERMINAL BLOCK BRACKET	10	2
8	311270	WASHER, TERMINAL BLOCK	10	3
9	312209	SCREW, #10-24 X 3/4 INCH Note: SCREW, TERMINAL BLOCK	10	2
10	312184	STRAP, GROUND	10	1
11	33001795	COVER, TERMINAL BLOCK	10	1
12	311484	NUT, TERMINAL BLOCK	10	3
13	311093	WASHER, 7/32 INCH Note: WASHER, BRASS	10	1
14	33001244	BLOCK, TERMINAL	10	1
15	33002060	BRACKET, SECURITY	10	2
16	22001502	FASTENER, U-NUT	10	2
17	22003646	CABINET ASSY. (WHT. AS PK)	38	1
17	33002000	CABINET (WHT)	10	1
18	33001980	CLIP, ACCESS PANEL	10	2
-	251119	SCREW Note: SCREW, RELAY BRACKET	10	2
19	314627	RELAY BRACKET	10	1
-	251119	SCREW Note: SCREW, RELAY	10	1
20	306398	RELAY - SPST HEATER Note: RELAY	10	1
21	213007	SCREW, CABINET	10	6
22	33001991	BOLT, CARRIAGE	10	5
23	314174	TERMINAL COVER - CANADA Note: COVER, TERMINAL (CAN)	10	1
-	22001995	SCREW Note: SCREW, TERMINAL COVER	10	4
24	206824	RELAY, SPST 24VDC	10	1
25	33002515	CORD, POWER	10	1
-	22002532	GROMMET, CORD	10	1

*Color Code (-)=Not Shown #=Series, Serial Prefix or Run No., N=Not Available

Section: WIRING INFORMATION

Model: MLG19PDAGW

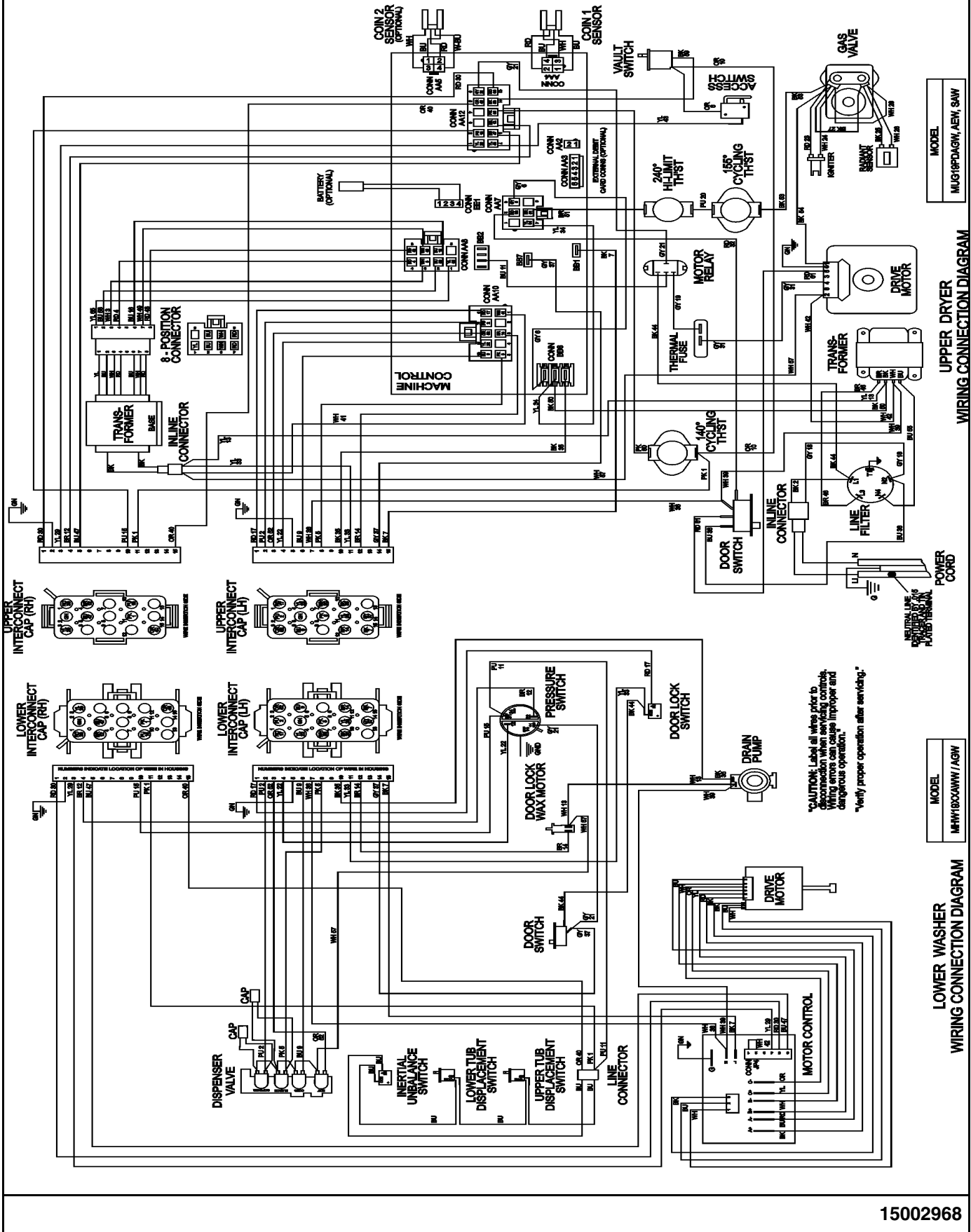

MODEL
MLG19PDAGW, AEW, SAW

UPPER DRYER
WIRING CONNECTION DIAGRAM

MODEL
MHW1900AWW / AGW

LOWER WASHER
WIRING CONNECTION DIAGRAM



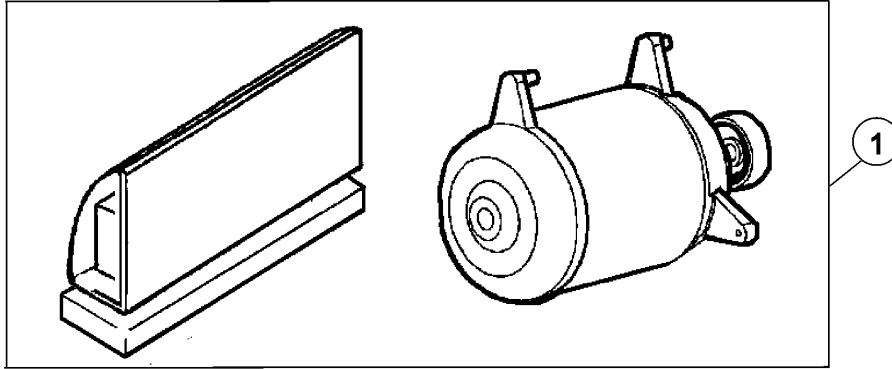

15002968

Section: MOTOR & MOTOR CONTROL

Model: MLG19PDAGW

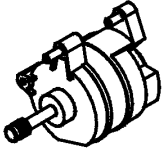
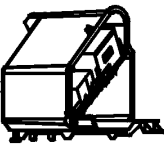
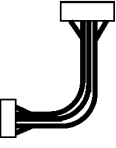
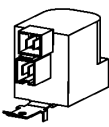
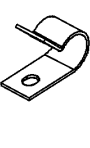

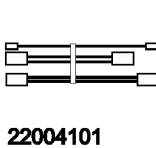
**ITEM 1
KIT CONTAINS:**

 <p>120002040 MOTOR W/ISOLATORS</p>	 <p>22004046 MOTOR CONTROL BOARD</p>	 <p>22004047 MOTOR HARNESS</p>	 <p>22003854 AC LINE FILTER</p>	 <p>22004102 "P" CLIPS (2)</p>	 <p>22002300 SCREW "P" CLIPS TO MOTOR</p>	 <p>22004101 LOWER JUMPER WIRE HARNESS</p>	 <p>22004103 SCREW GROUND</p>
---	--	--	---	--	---	--	---

(SEE TEXT FOR ITEMS 2, 3, 4 AND 8)

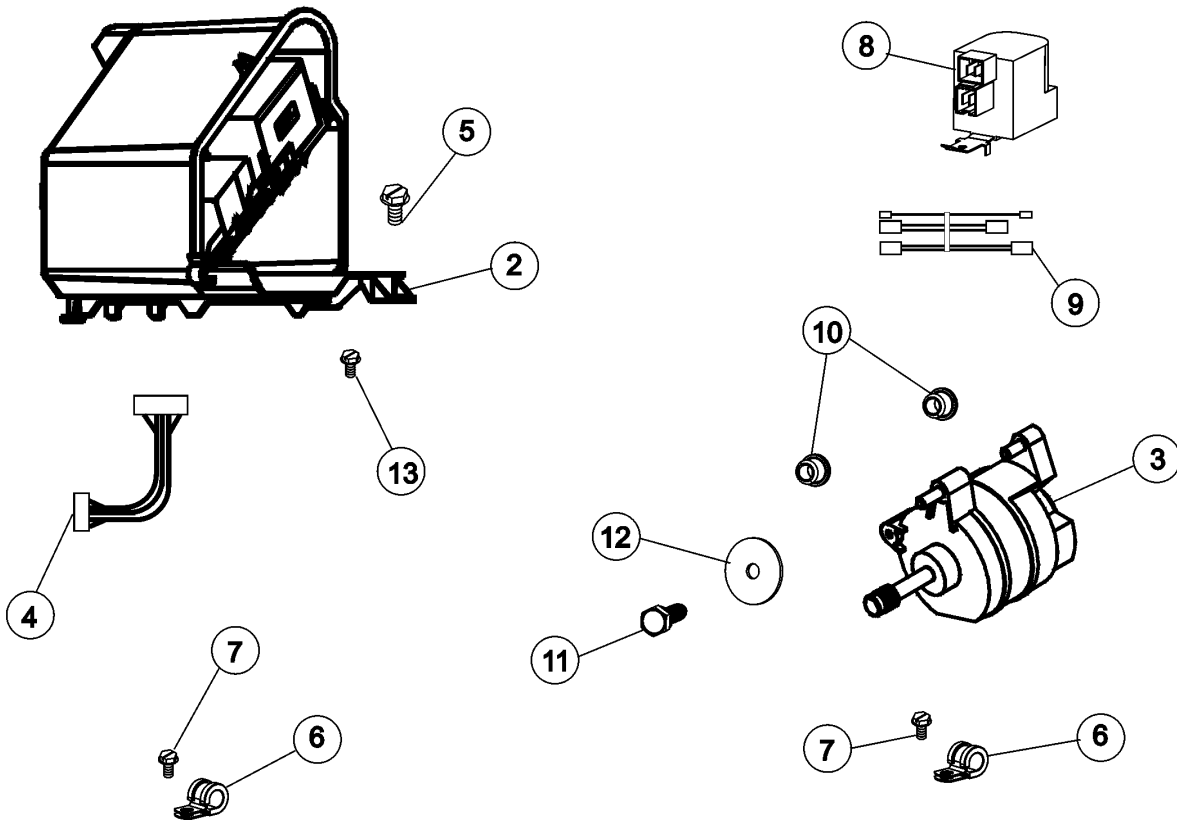

CW23-04

Section: MOTOR & MOTOR CONTROL

No.	Part No.	Description	Series	Qty
1	12002039	NEPTUNE MOTOR CONVERSION KIT	10	1
2	22004046	CONTROL ASSY., MOTOR	10	1
3	22003856	MOTOR, VARIABLE SPEED	10	1
4	22004047	HARNES, MOTOR/MOTOR CONTROL	10	1
5	33002190	SCREW (#10-3/8")	10	2
6	22004102	P CLIPS	10	2
7	22002300	SCREW	10	2
8	22003854	EMI SUPPRESSION FILTER, 12A	10	1
9	22004101	REPAIR JUMPER HARNES	10	1
10	22003329	ISOLATOR, MOTOR	10	2
11	22003686	BOLT, MOTOR	10	1
12	22002320	WASHER, STRUT	10	1
13	22004103	SCREW	10	1

*Color Code (-)=Not Shown #=Series, Serial Prefix or Run No., N=Not Available

