

## STACKED DRYER

# Repair Parts List

MODEL NUMBER  
MLG23PDFWW

When requesting service or ordering parts, always provide the following information:

- Product Type
- Part Number
- Model Number
- Part Description

**MAYTAG**®

©2005 Maytag Services

Section: CONTROL PANEL

Model: MLG23PDFWW

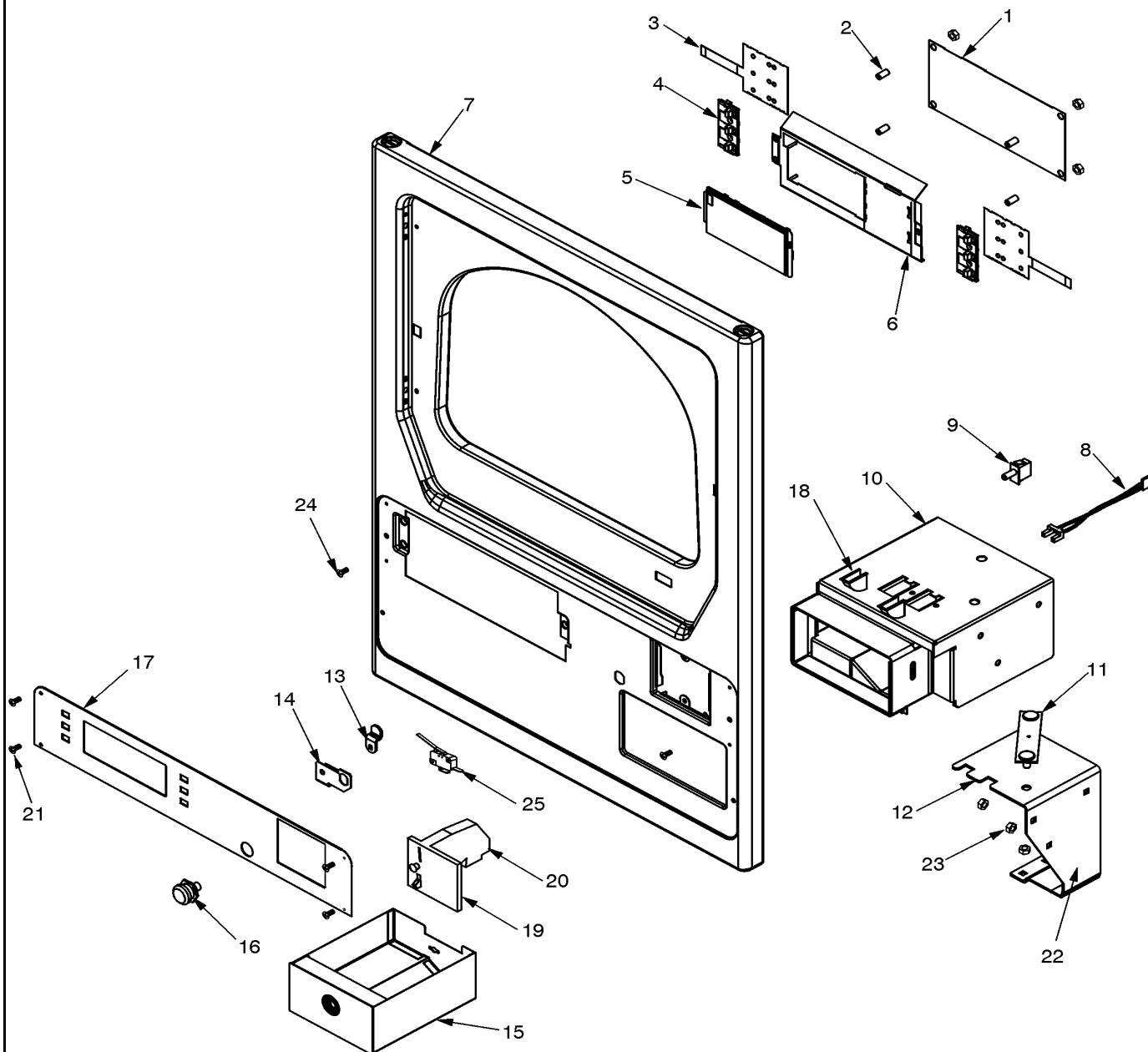

CD11-90

## Section: CONTROL PANEL

No.	Part No.	Description	Series	Qty
-	912077	LOCKNUT	10	4
1	33002608	BOARD, CONTROL	10	1
2	33001204	STANDOFF, CIRCUIT BOARD	10	4
3	33002152	SWITCH, MEMBRANE	10	1
4	215517	PUSHBUTTON	10	2
5	33002150	COVER, DISPLAY	10	1
6	33002155	PLATE, CONTROL MOUNTING	10	1
7	33002823	PANEL, PD FLAT FRONT	10	1
8	22001965	SWITCH ASSY., OPTIC	10	1
-	314665	SCREW	10	1
9	33001250	SWITCH, SENSOR	10	1
10	22004157	ASSY, COIN VAULT----NA	10	1
11	22001810	STRAP, MOUNTING	10	1
-	910181	LOCK WASHER	10	2
12	33002763	VAULT MOUNTING BRACKET	10	1
13	213750	LOCKING CAM	10	1
14	33001982	BRACKET, SWITCH MOUNTING	10	1
15	22004158	ASSY, COIN BOX	10	1
16	22002349	LOCK, ACCESS DOOR	10	1
17	33002828	FACIA, COMM. - PD D/D	10	1
18	314635	COIN CHUTE	10	2
19	33002647	SINGLE FACEPLATE ASSEMBLY	13	1
19	33002647	SINGLE FACEPLATE ASSEMBLY	10	1
20	33002648	COIN DROP-U.S. (0.25)	10	1
-	22003678	ASSY, COIN DROP U.S. \$0.25	10	1
20	22004112	COIN DROP GREENWALD US.25	13	1
21	215506	SCREW, TORX	10	4
22	33001991	BOLT, CARRIAGE	10	3
23	Y052734	NUT	10	5
24	33002051	SCREW, TORX	10	2
25	33002117	SWITCH, SENSOR	10	1

\*Color Code (-)=Not Shown #=Series, Serial Prefix or Run No., N=Not Available

Section: CABINET FRONT

Model: MLG23PDFWW

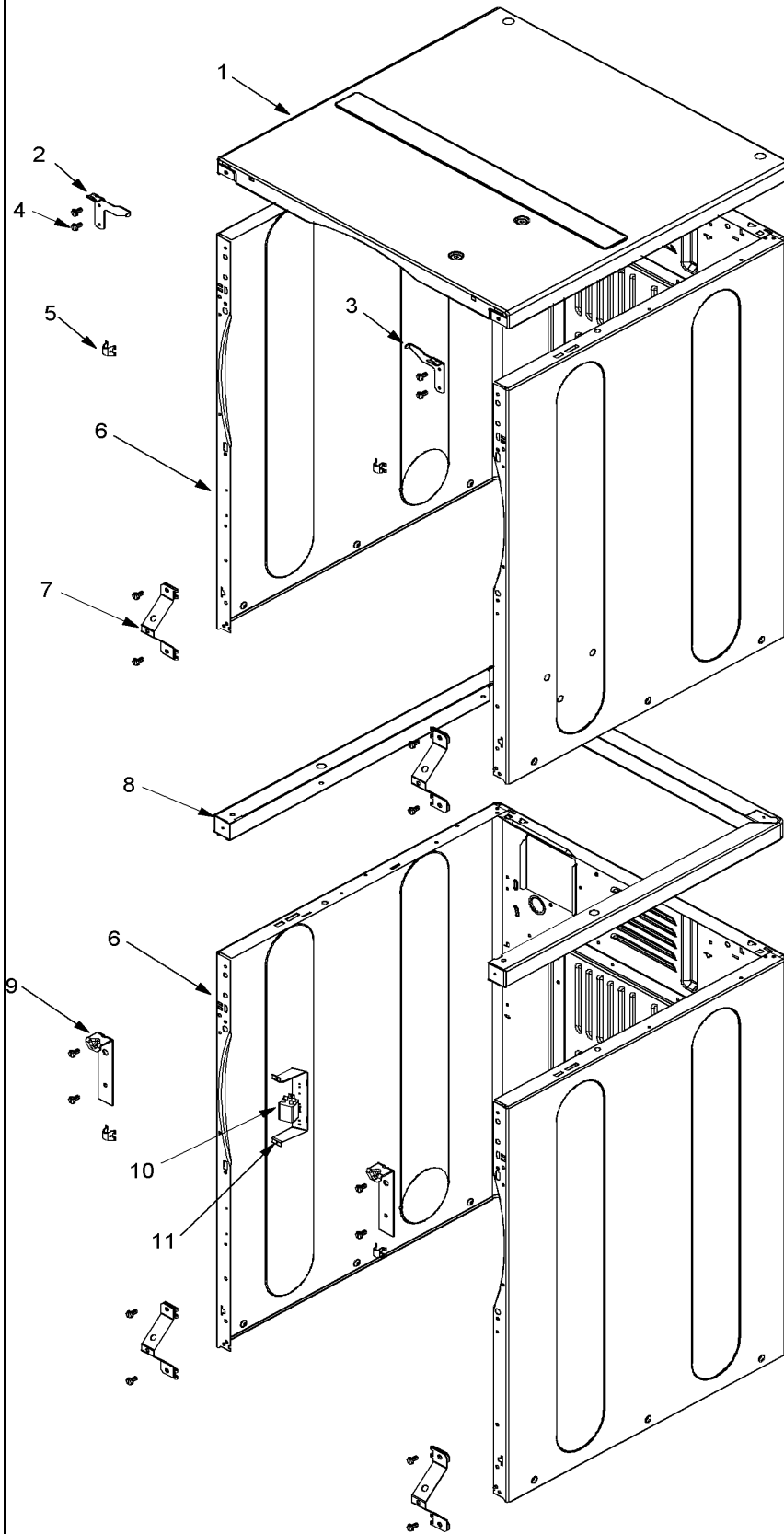

## Section: CABINET FRONT

No.	Part No.	Description	Series	Qty
1	33002124	COVER, TOP (WHT)	10	1
-	22001402	SCREW	10	2
2	33002818	BRACKET, LH UPPER FRONT PANEL	10	2
3	33002819	BRACKET, RH UPPER FRONT PANEL	10	1
4	22001995	SCREW	10	4
5	33001980	CLIP, ACCESS PANEL	10	4
6 N	22003643	CABINET ASSY. (WHT AS PK)	10	2
6	33002839	CABINET, UPPER PD	10	1
7	22002425	BRACKET, "V"	10	4
-	22001995	SCREW	10	8
-	22001402	SCREW	10	4
8	33002820	SUPPORT WELD ASS'Y	10	1
9	33002821	BRACKET, FRONT LOWER PANEL	10	2
-	22001995	SCREW	10	4
10	22004151	RELAY, SPST	10	1
-	251119	SCREW	10	1
-	22001995	SCREW	10	2
11	314627	RELAY BRACKET	10	1

\*Color Code (-)=Not Shown #=Series, Serial Prefix or Run No., N=Not Available

Section: CABINET REAR

Model: MLG23PDFWW

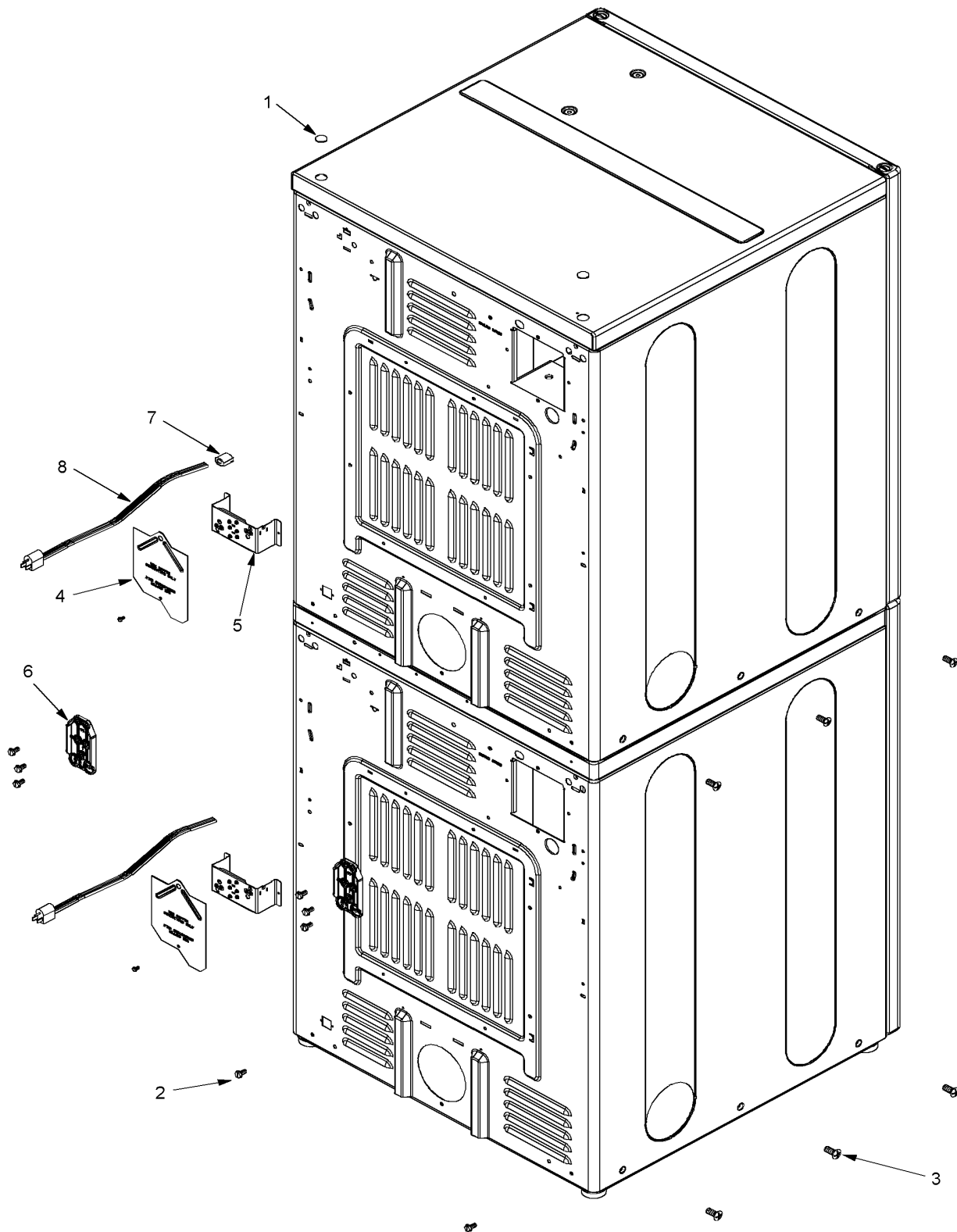

CD18-29

**Section: CABINET REAR**

No.	Part No.	Description	Series	Qty
1	33001997	PLUG, HOLE	10	2
2	22001995	SCREW	10	2
3	213007	SCREW, CABINET	10	12
4	33001795	COVER, TERMINAL BLOCK	10	1
-	22001995	SCREW	10	1
-	22001995	SCREW	10	2
-	33001244	BLOCK, TERMINAL	10	1
5	N 33001826	BRACKET, TERMINAL BLOCK----NA	10	1
-	22001995	SCREW	10	6
6	33002829	BRACKET, REAR SUPPORT	10	2
7	211881	GROMMET, CORD	10	1
8	22003062	CORD, POWER (AS WRAPPED)	10	1

\*Color Code (-)=Not Shown #=Series, Serial Prefix or Run No., N=Not Available

Section: FRONT PANEL

Model: MLG23PDFWW

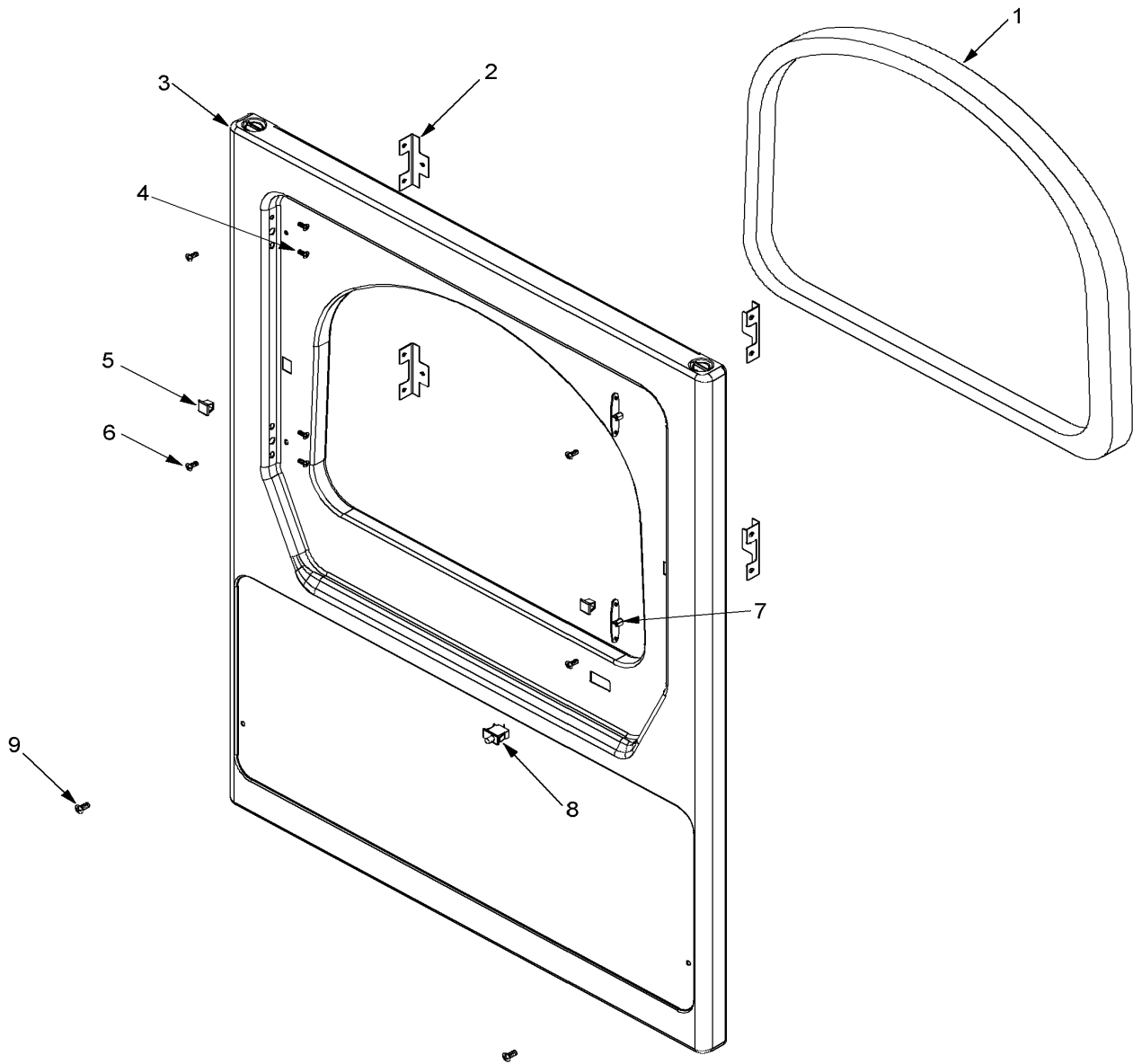



## Section: FRONT PANEL

No.	Part No.	Description	Series	Qty
1	33001767	SEAL, SHROUD	10	1
2	33002025	TWIN SPEEDNUT	10	4
3	33002823	PANEL, PD FLAT FRONT	10	1
3	33002825	PANEL, FLAT FRONT LOWER	10	1
4	22002062	SCREW	10	4
5	Y304578	CATCH, DOOR (FEMALE)	10	2
6	33001486	PANEL, FASTENER	10	4
7	33001175	COVER, HINGE HOLE (WHT)	10	2
8	33001509	SWITCH, DOOR	10	1
9	33002881	SCREW, SECURITY #10-16X1/2	10	2

\*Color Code (-)=Not Shown #=Series, Serial Prefix or Run No., N=Not Available

Section: DOOR

Model: MLG23PDFWW

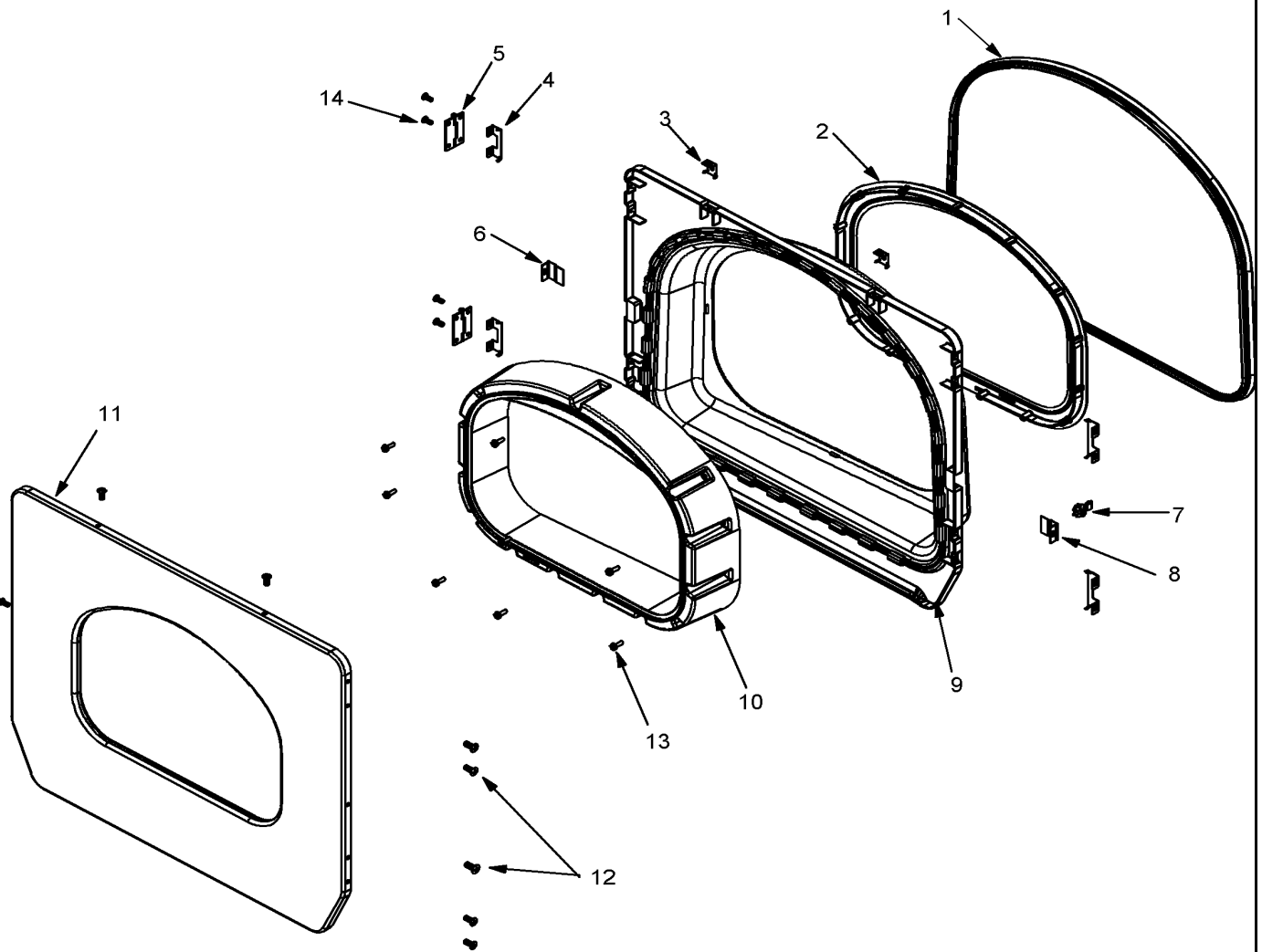

CD12-24

## Section: DOOR

No.	Part No.	Description	Series	Qty
1	33002094	SEAL, DOOR	10	1
2	33002607	LENS	10	1
3	22002039	CLIP, DOOR (SINGLE)	10	1
4	22002038	CLIP, DOOR (DOUBLE)	10	4
5	33002017	HINGE, DOOR	10	2
6	33001763	PLUG, INNER DOOR	10	1
7	33001761	STRIKE, DOOR (MALE)	10	1
8	33001793	BRACKET, STRIKE	10	1
9	33002020	DOOR, INNER (WHT)	10	1
10	33002780	DOOR TUNNEL W' HANDLE (WHT)	10	1
11	33002015	DOOR, OUTER (WHT)	10	1
12	22002063	SCREW #8-18AB WAFER HD	10	8
13	22002300	SCREW	10	7
14	22002062	SCREW	10	4

\*Color Code (-)=Not Shown #=Series, Serial Prefix or Run No., N=Not Available

Section: TUMBLER

Model: MLG23PDFWW

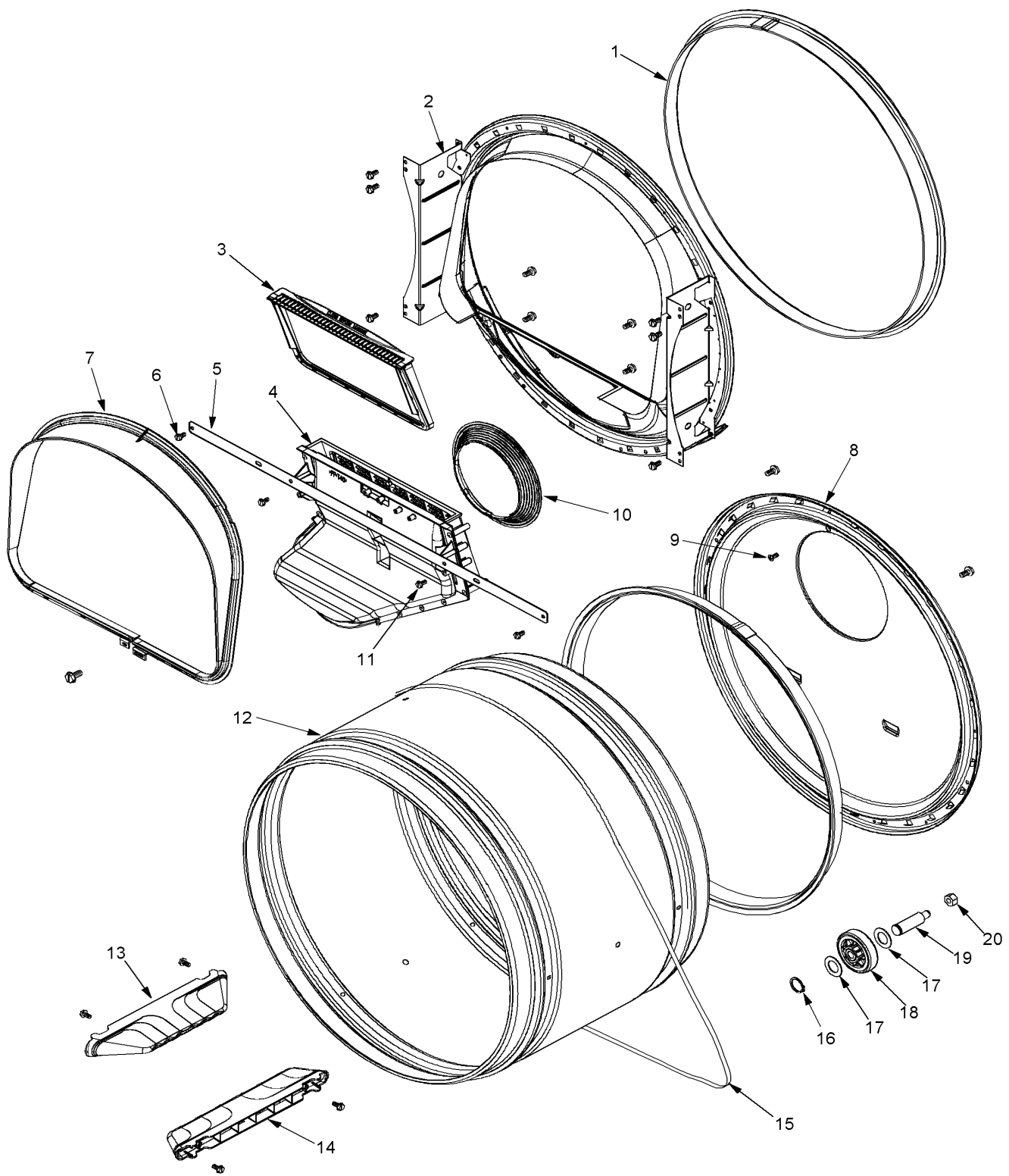

CD16-30

## Section: TUMBLER

No.	Part No.	Description	Series	Qty
1	33001807	SEAL, TUMBLER	10	2
-	22001995	SCREW	10	6
2	33001802	FRONT, TUMBLER (W/SEAL)	10	1
3	33001804	FILTER, LINT	10	1
4	33001799	OUTLET DUCT ASSEMBLY	10	1
-	22001995	SCREW	10	4
5	33002039	BRACE, TUMBLER FRONT	10	1
6	22001995	SCREW	10	2
-	22001995	SCREW	10	4
7	33002026	EXTENSION, TUMBLER FRONT	10	1
-	22001995	SCREW	10	4
8	33002779	TUMBLER BACK & SEAL AS-PACK	10	1
9	N 312311	SCREW---NA	10	2
10	33002560	SEAL, BLOWER	10	1
11	33001768	SCREW, SHROUD	10	4
12	33001794	TUMBLER	10	1
-	33001788	SCREW, BAFFLE	10	4
13	33001756	BAFFLE (TALL)	10	2
14	33001755	BAFFLE (SHORT)	10	1
-	33001788	SCREW, BAFFLE	10	2
15	33002535	V-BELT (TUMBLER)	10	1
16	410233	RING, RETAINING	10	2
17	312535	WASHER, ROLLER SHAFT	10	4
18	Y303373	BEARING & ROLLER ASSEMBLY	10	2
19	312948	SHAFT, TUMBLER ROLLER	10	2
20	33001443	NUT, HEX (ROLLER SHAFT)	10	2

\*Color Code (-)=Not Shown #=Series, Serial Prefix or Run No., N=Not Available

Section: GAS VALVE

Model: MLG23PDFWW

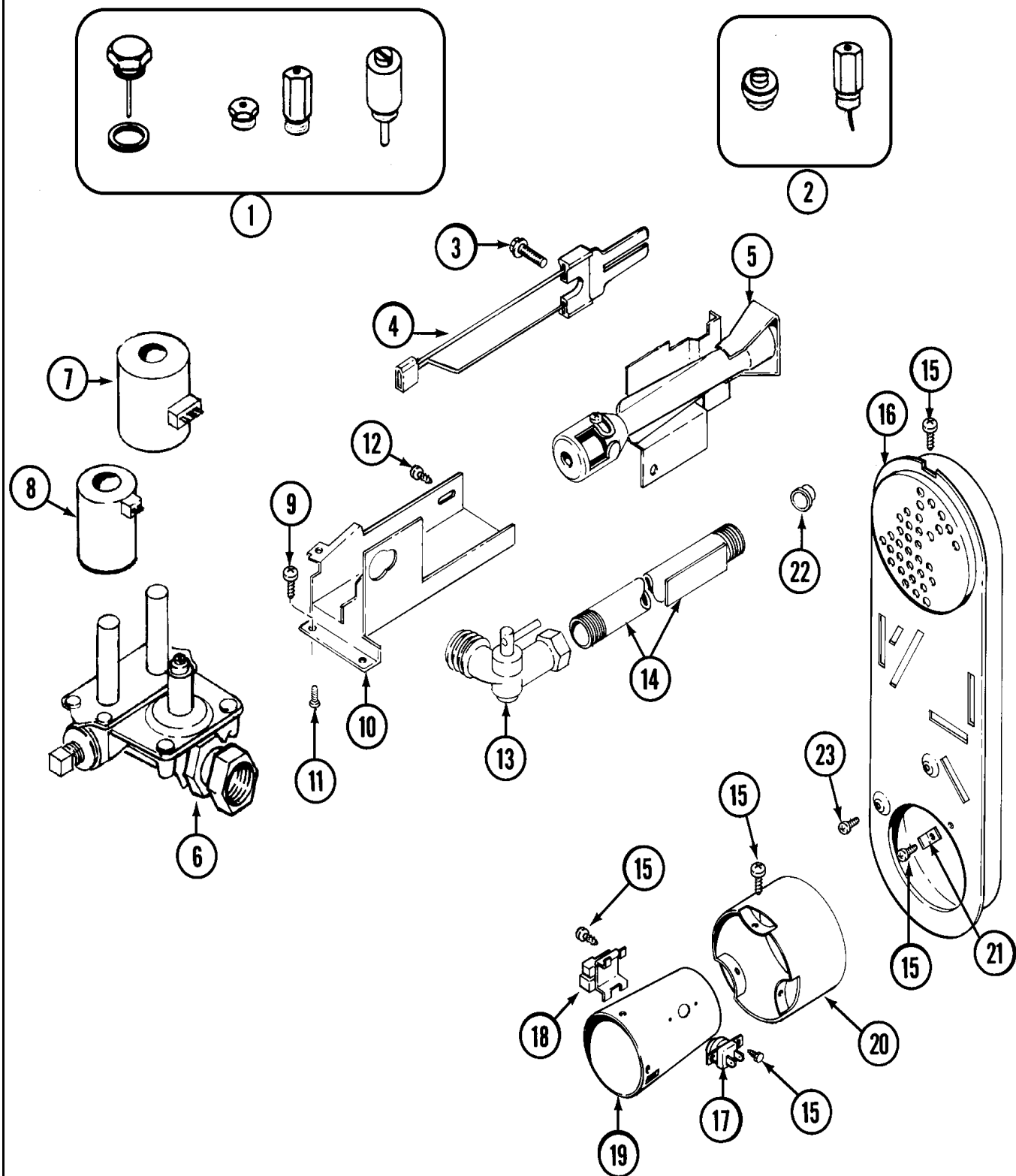

CD14-1

## Section: GAS VALVE

No.	Part No.	Description	Series	Qty
1	308378	CONVERSION KIT (NATURAL TO LP)	10	1
2	Y308377	CONVERSION KIT (LP TO NATURAL)	10	1
3	304971	SCREW	10	1
4	304970	IGNITER ASSY, GAS VALVE	10	1
4	33002789	IGNITER ASSEMBLY	11	1
5	33002793	BURNER ASSEMBLY	10	1
6	308345	VALVE, GAS	10	1
7	306106	COIL, HOLDING & BOOSTER	10	1
8	306105	COIL, SECONDARY	10	1
9	N 313561	SCREW----NA	10	1
10	33002710	BRACKET, GAS CONTROL	10	1
11	N 313561	SCREW----NA	10	2
12	22001995	SCREW	10	2
13	306086	ANGLE SHUT OFF FOR GAS VALV	10	1
14	33001735	PIPE & BRACKET ASSY.	10	1
15	211294	SCREW	10	14
16	33002765	INLET DUCT ASSEMBLY (GAS)	10	1
17	305169	THERMOSTAT, HI-LIMIT GAS	10	1
18	303377	SENSOR, RADIANT	10	1
19	33001835	CONE ASSY., COMBUSTION	10	1
20	33001812	EXTENSION CONE ASSY.	10	1
21	Y312890	RETAINER, HEATER CHAMBER	10	1
22	33001693	CAP, GAS PIPE	10	1
23	211294	SCREW	10	1

\*Color Code (-)=Not Shown #=Series, Serial Prefix or Run No., N=Not Available

Section: BLOWER

Model: MLG23PDFWW

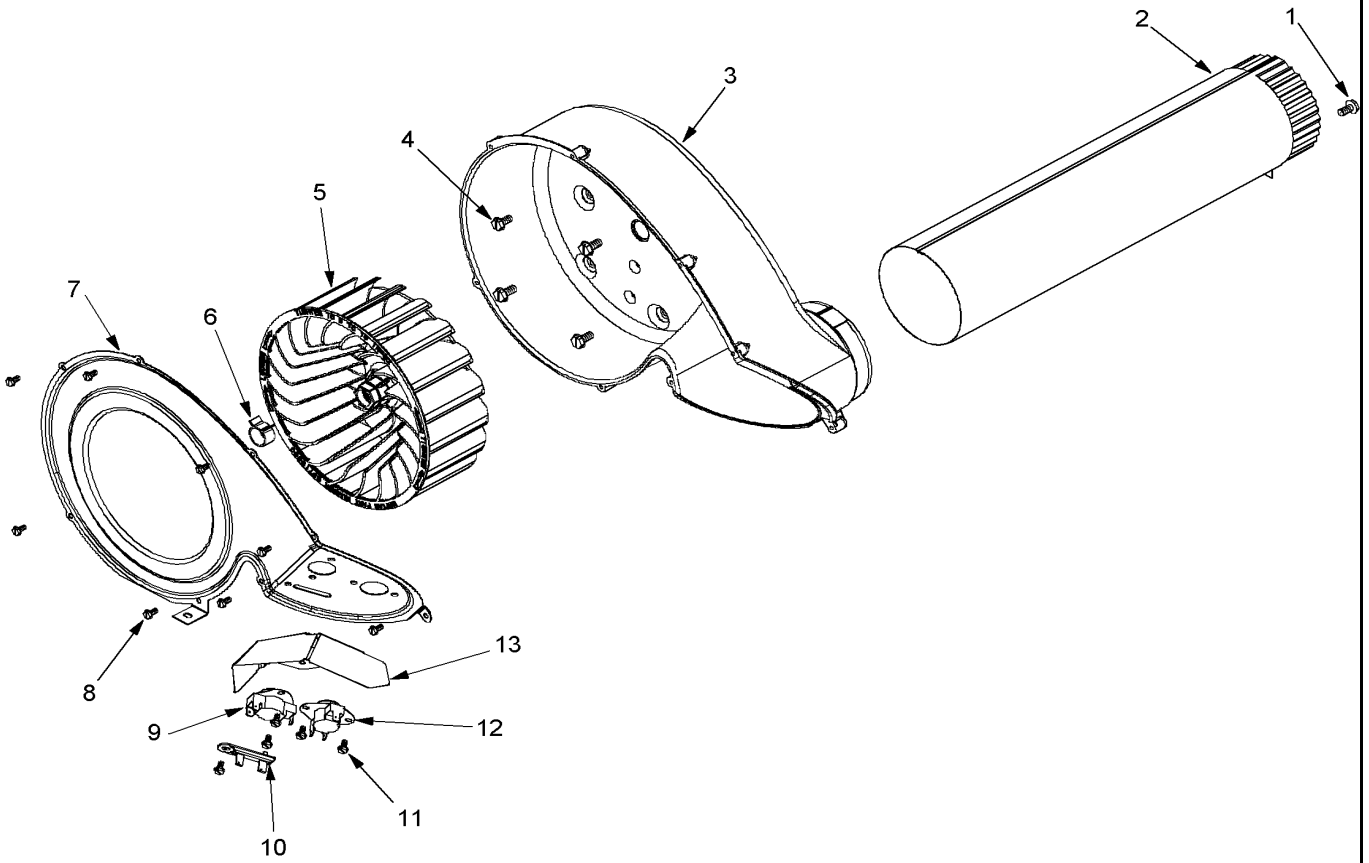



## Section: BLOWER

No.	Part No.	Description	Series	Qty
1	22001995	SCREW	10	1
2	33001799	OUTLET DUCT ASSEMBLY	10	1
3	33001789	HOUSING, BLOWER	10	1
4	310632	SCREW	10	4
5	33002797	WHEEL, BLOWER	10	1
6	312967	CLAMP, BLOWER HOUSING	10	1
7	33002711	COVER, BLOWER HOUSING	10	1
8	33001855	SCREW (HEX HEAD)	10	8
9	303392	CYCLING THERMOSTAT 140 DEG.	10	1
10	33001762	FUSE, THERMAL (W' BRACKET)	10	1
11	22002925	SCREW	10	5
12	33303391	THERMOSTAT, CYCLING	10	1

\*Color Code (-)=Not Shown #=Series, Serial Prefix or Run No., N=Not Available

Section: BASE

Model: MLG23PDFWW

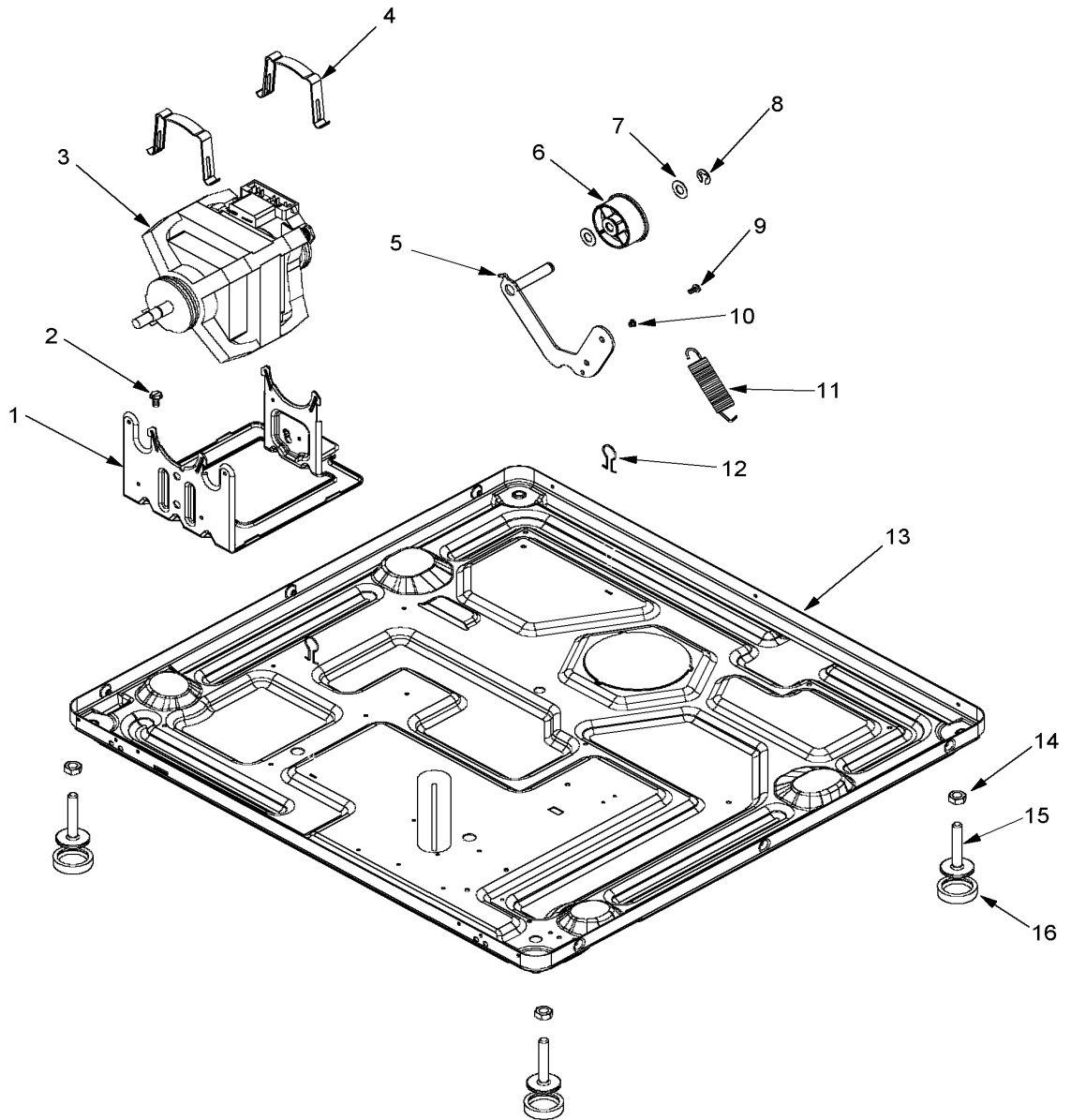

## Section: BASE

No.	Part No.	Description	Series	Qty
1	33002817	MOTOR SUPPORT, OFFSET	10	1
2	N 313561	SCREW----NA	10	1
3	33002795	MOTOR, DRIVE 60HZ	10	1
4	33002221	CLIP, MOTOR	10	2
5	33001840	IDLER ARM & SHAFT ASSY.	10	1
6	33001783	BEARING, IDLER ASSEMBLY	10	1
7	312527	WASHER, IDLER SHAFT (QTY-1)	10	2
8	312958	RETAINING RING, IDLER SHAFT	10	1
9	Y014874	SCREW	10	1
10	33002218	GROMMET, IDLER ARM	10	1
11	33002460	SPRING, IDLER	10	1
12	410490	SPRING, WIRE HARNESS	10	2
13	N 33002465	BASE, (LWR)----NA	10	1
13	33002816	BASE (UPR)	10	1
-	33002186	TRANSFORMER	10	1
14	Y052740	NUT	10	4
15	22003544	ADJUSTABLE LEG W/FOOT & NUT	10	4
16	210684	FOOT, RUBBER	10	4

\*Color Code (-)=Not Shown #=Series, Serial Prefix or Run No., N=Not Available

**Section: SUPPLEMENTAL INFORMATION**

No.	Part No.	Description	Series	Qty
-	33002848	HARNESS, WIRE LOWER GAS PR/PD	10	1
-	33002847	HARNESS, WIRE UPPER GAS PD	10	1
-	33002535	V-BELT (TUMBLER)	10	1
-	33002902	INSTRUCTIONS, INSTALLATION	10	1
-	33002903	INSTRUCTIONS, OPERATING	10	1

\*Color Code (-)=Not Shown #=Series, Serial Prefix or Run No., N=Not Available

# Section: WIRING INFORMATION(GAS)

## Model: MLG23PDFWW

### Diagnostic Mode:

This mode is entered by depressing the **LOWER DRYER DELICATES** key pad for 1 second while in any of the set-up codes one through six, anytime a diagnostic code is present, or while dAS displays if operating with Maytag Data Acquisition setup.

On entry to diagnostic mode the entire display will flash, any cycles in process will be cancelled, money in escrow will be cleared, and diagnostic codes are cleared. If a diagnostic code persists on either of the machines, the fault must be corrected before the following cycle options are permitted.

Procedures to initiate cycle activity from diagnostic mode are as follows:

- 1. Upper Dryer Field Diagnostic Cycle** - With the entire display flashing, the cycle is started by pressing the **UPPER DRYER PERMANENT PRESS** key pad. The cycle consists of seven minutes of heat and one minute of cool down. The **UPPER DRYER WHITES & COLORS** key pad will increment the diagnostic cycle minutes up to 99, then roll over to 2 minutes. Pressing the **LOWER DRYER DELICATES** key pad will cancel this cycle and exit the diagnostic mode.
- 2. Lower Dryer Field Diagnostic Cycle** - With the entire display flashing, the cycle is started by pressing the **LOWER DRYER PERMANENT PRESS** key pad. The cycle consists of seven minutes of heat and one minute of cool down. The **LOWER DRYER WHITES & COLORS** key pad will increment the diagnostic cycle minutes up to 99, then roll over to 2 minutes. Pressing the **LOWER DRYER DELICATES** key pad will cancel this cycle and exit the diagnostic mode.

### Diagnostic Codes:

If the set-up mode is entered and one of the following has occurred, the appropriate diagnostic code will be in the display.

- d1** - Upper dryer door sense error on control board or due to power line interference (upper dryer cycles and upper dryer display disabled until diagnostic code is manually cleared).
- d4** - Lower dryer motor control circuit error (lower dryer cycles and lower dryer display disabled until diagnostic code is manually cleared).
- d5** - Blocked coin 1 or coin drop control circuit failure (coin recognition and entire display disabled while blockage persists).
- d9** - Voltage detected below 90vac for 8 seconds.
- d12** - Lower dryer motor sense error on control board or due to power line interference (lower dryer cycles and lower dryer display disabled until diagnostic code is manually cleared).
- d13** - Blocked coin 2 or coin drop control circuit failure (coin recognition and entire display disabled while blockage persists).
- d14** - Upper dryer motor sense error on control board or due to power line interference (upper dryer cycles and upper dryer display disabled until diagnostic code is manually cleared).
- d16** - Not receiving communications from installed debit card reader in Enhanced (Generation 2) Debit mode.
- d17** - Lower dryer door sense error on control board or due to power line interference (lower dryer cycles and lower dryer display disabled until diagnostic code is manually cleared).
- d20** - Upper dryer motor control circuit error (upper dryer cycles and upper dryer display disabled until diagnostic code is manually cleared).

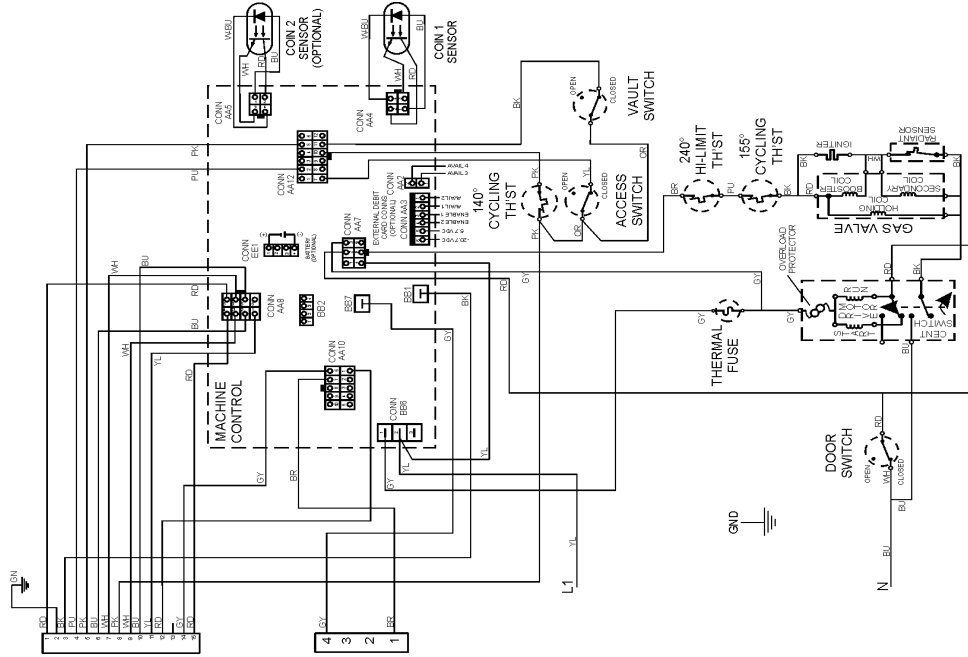

UPPER DRYER-PD ELECTRICAL SCHEMATIC

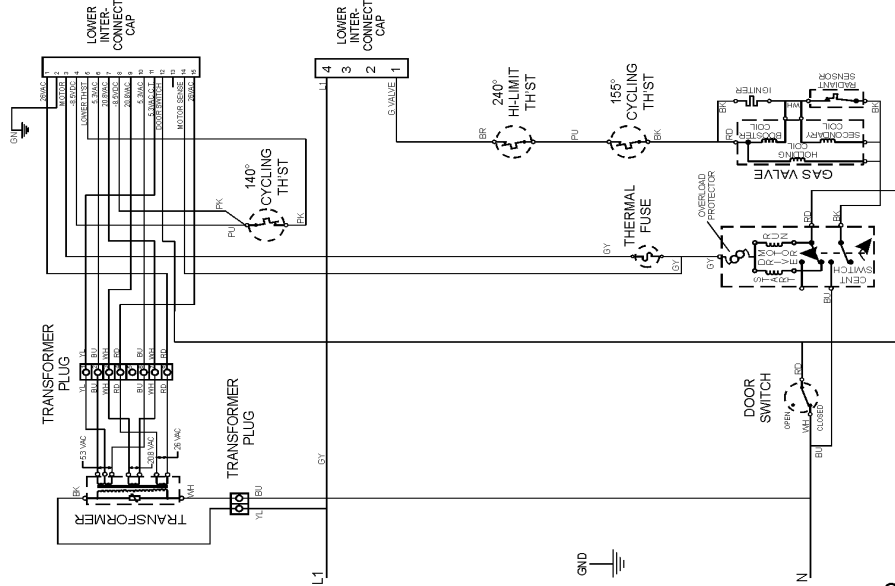

LOWER DRYER-PD ELECTRICAL SCHEMATIC

6 3720390

15003172

**Section: WIRING INFORMATION(GAS)**

No.	Part No.	Description	Series Qty
1	N 15003172	WIRING INFORMATION	10 1

\*Color Code (-)=Not Shown #=Series, Serial Prefix or Run No., N=Not Available

