

WASCOMAT

Spare Parts Catalogue

Catalogue de pièces de rechange

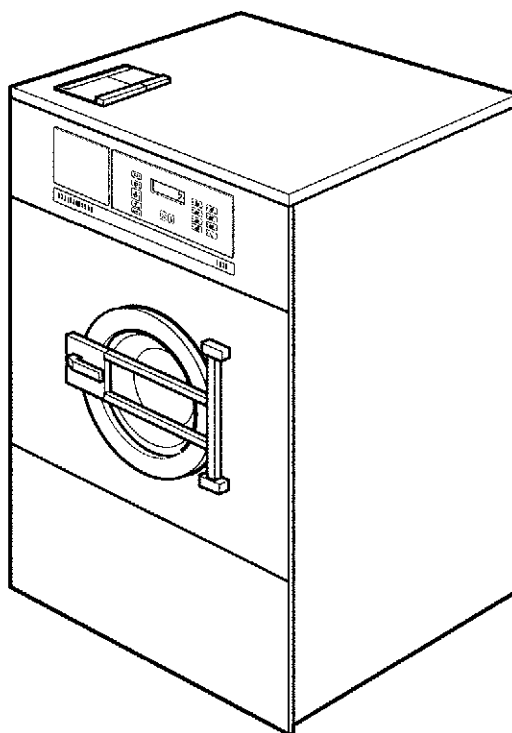

EXSM 230S, EXSM 230C

List of issues

EXSM 230C,EXSM 230S

Illustration	Page	Table of contents
100568	45	Inlet valve 1/2", 3/4", 1", 1 1/4", 2"
100634	47	Detergent container
100797	43	Inlet valve 3/4", 3-way
101625	27	Motor control
101634	23	Control unit
101635	25	Control unit
101685	7	Base and outer drum
101686	37	Door locking system
101687	39	Door locking device
101688	9	Lining and top panel
101689	13	Door and hinged joint
101690	11	Back plate with inner drum, bearing, pulley
101691	35	Electric components
101692	15	Motor and motor suspension
101694	21	Control panel
101695	29	Drain valve and hoses
101696	31	Water connections
101698	33	Electric components
101797	41	Steam components
102189	17	Motor and motor suspension
102190	19	Control panel

EXSM 230C, EXSM 230S

Table of contents	Table des matières	Page/Page
Base and outer drum	Base et tambour externe	7
Lining and top panel	Panneau frontal avec pupitre de commande	9
Back plate with inner drum, bearing, pulley	Pignon arrière avec tambour intérieur, palier, poulie	11
Door and hinged joint	Assemblage articulé et plaque	13
Motor and motor suspension	Purgeur et flexible	15
Motor and motor suspension	Purgeur et flexible	17
Control panel	Pupitre de commande	19
Control panel	Pupitre de commande	21
Control unit	Unité de contrôle	23
Control unit	Unité de contrôle	25
Motor control	Contrôle du moteur	27
Drain valve and hoses	Purgeur et flexible	29
Water connections	Raccords d'eau	31
Electric components	Composants électriques	33
Electric components	Composants électriques	35
Door locking system	Serrure de porte	37
Door locking device	Serrure de porte	39
Steam components	Composants	41
Inlet valve 3/4", 3-way	Soupape de admission 3/4", 3 voies	43
Inlet valve 1/2", 3/4", 1", 1 1/4", 2"	Soupape de admission 1/2", 3/4", 1", 1 1/4", 2"	45
Detergent container	Compartiment à savon	47

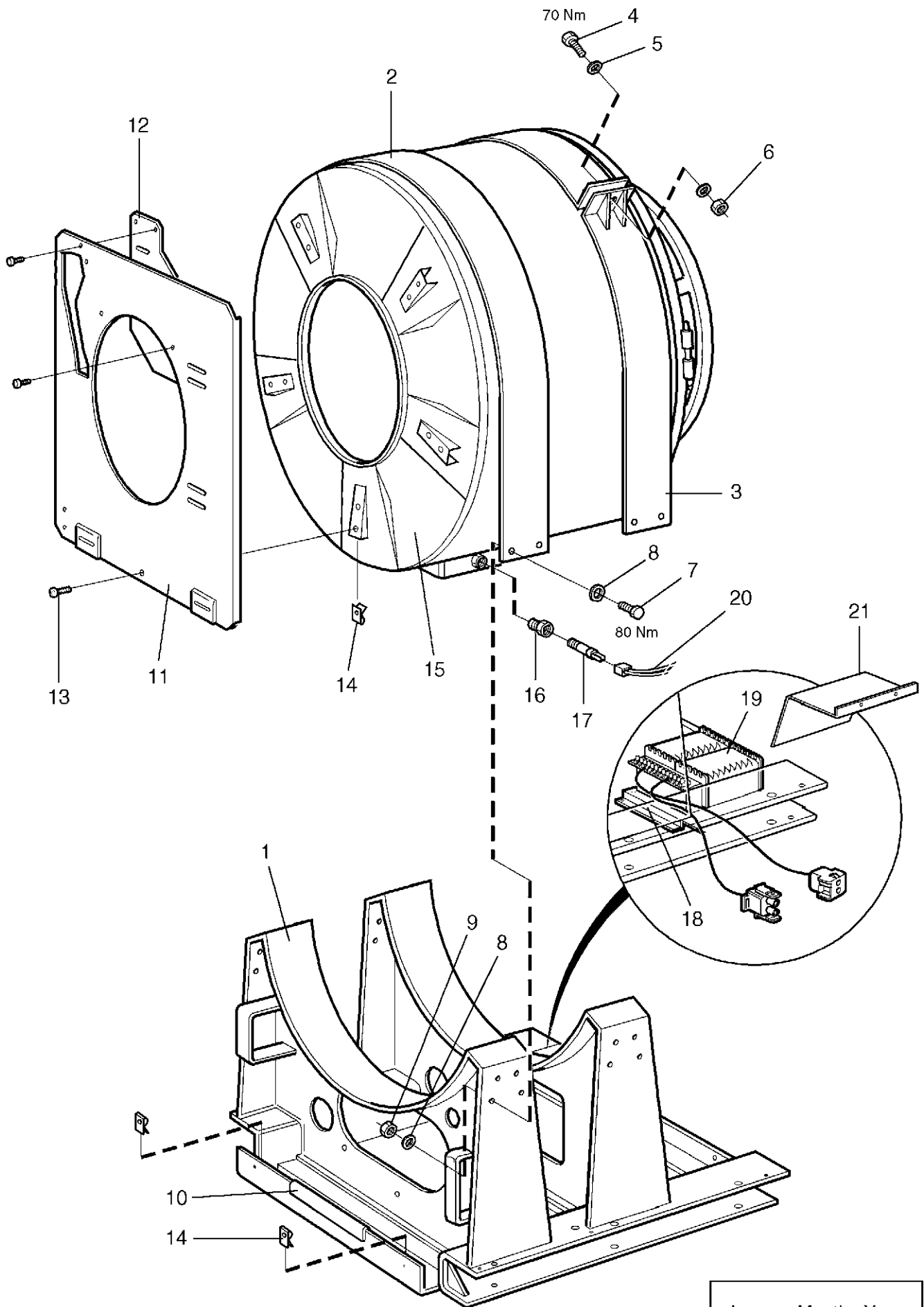

EXSM 230C,EXSM 230C -06230/4601,EXSM 230S

Base and outer drum

Base et tambour externe

Illustration Issue Month Year
Schéma Issue Month Year
101685/4 5 2 2003

Item Article	Quantity Quantité	Art.No Réf. article	Description	Description	Info Info	Notes Remarques
			EXSM 230S			
			EXSM 230C			
1	1	432 0940-02	Frame	Base	3	
2	2	438 4184-01	Tension strap	Extenseur	3	
3	2	438 4182-01	Tension strap	Extenseur	3	
4	2	725 2630-51	Screw	Vis	3	M16X50
5	4	734 1186-01	Washer	Rondelle	3	BRB 17X30
6	2	732 2124-01	Locking nut	Contre-écrou	3	M16
7	8	725 2536-51	Screw	Vis	3	M12X30
8	16	734 1178-01	Washer	Rondelle	3	BRB 13X24
9	8	732 2122-01	Locking nut	Contre-écrou	3	M12
10	1	471 8180-12	Strip	Ruban	1,2	L=170
11	1	432 0921-01	End piece	Pignon	3	
12	1	432 0929-01	Plate	Plaque	3	
13	10	471 8341-46	Screw	Vis	3	M6X16
14	14	471 7864-01	Clip	Colliers de serrage	3	M6
15	1	438 4158-01	Outer drum	Extérieur du tambour	3	Hot water
	1	438 4158-02	Outer drum	Tambour extérieur	3	Steam heated
16	1	472 9913-22	Sensor	Capteur	1,2	Complete
17	1	471 8192-01	•Bushing	•Douille	1,2	
18	1	432 0647-01	Mounting plate	Plaque de montage	3	
19	1	438 9550-51	Transformer	Transformateur	1	346,380,440,480V T2
20	1	432 0549-25	Cable set	Jeu de câbles	3	
		432 0549-65	Cable set	Jeu de câbles	3	
21	1	432 0648-01	Drip guard	Lèche-goutte	3	

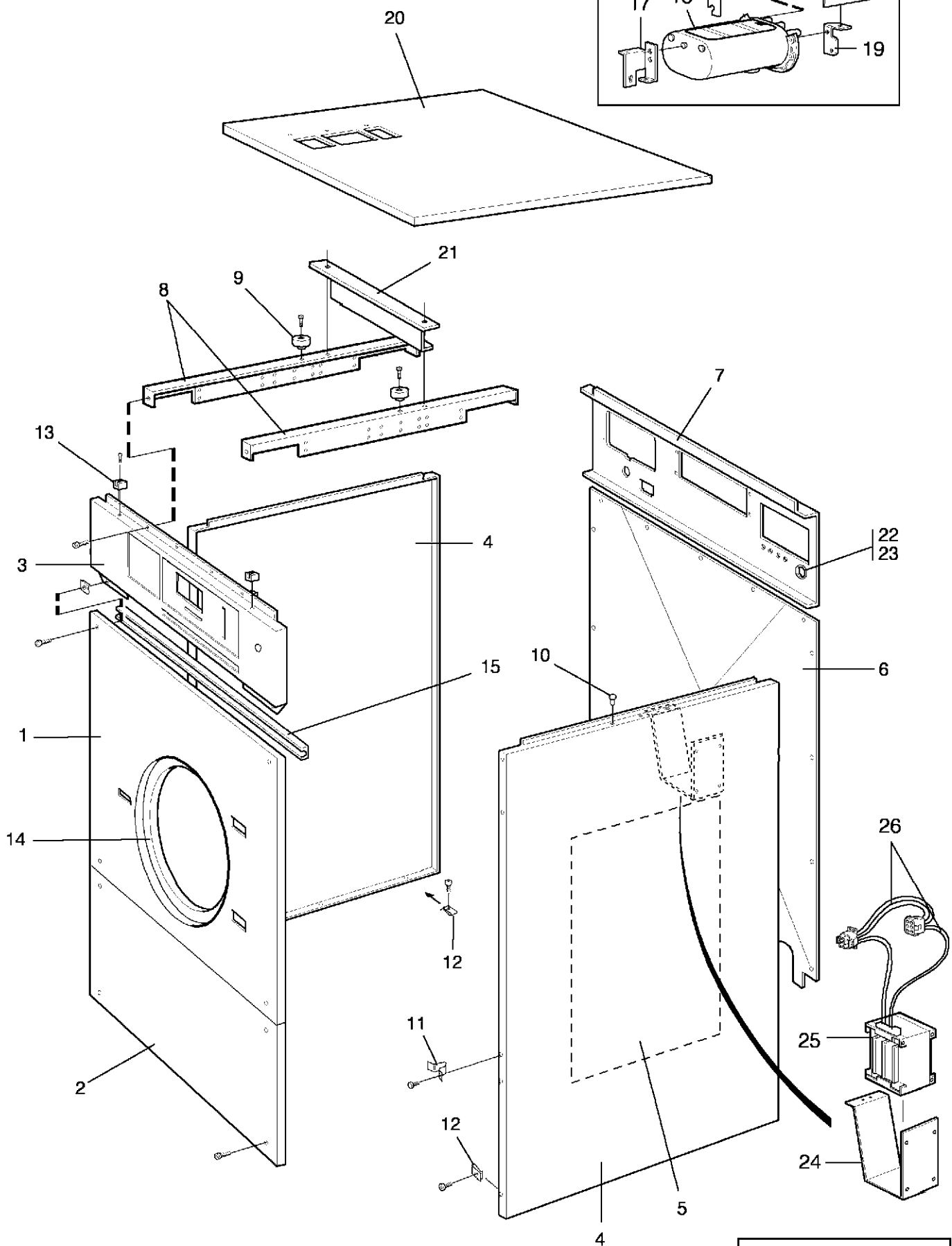
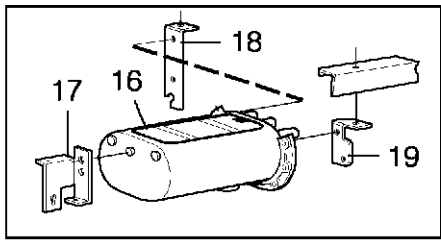

101688

Issue	Month	Year
02	06	00

EXSM 230C,EXSM 230S

Lining and top panel

Panneau frontal avec pupitre de commande

Illustration Issue Month Year
Schéma Issue Month Year
101688/2 5 9 2002

Item Article	Quantity Quantité	Art.No Réf. article	Description	Description	Info Info	Notes Remarques
			EXSM 230S			
			EXSM 230C			
1	1	1	438 4171-01	Front panel	Panneau avant	1 Stainless steel
			438 4171-09	Front panel	Panneau avant	1 Stainless steel Aqua clean
2	1	1	438 4172-01	Front panel	Panneau avant	1 Stainless steel
3	1		432 0919-01	Front panel	Panneau avant	3
			432 0919-03	Control panel	Panneau de commande	1 Emerald
			432 0920-01	Front panel	Panneau avant	3
4	2	2	432 0917-01	Side panel	Panneau latéral	3
			432 0917-02	Side panel	Panneau latéral	3 Stainless steel
5						Not used
6	1	1	438 4424-01	Rear panel	Panneau arrière	3 HW
7	1	1	432 0918-01	Brace bracket	Support de montant	3
8	2	2	432 0915-01	Brace	Montant	3 Upper
9	2	2	471 8149-11	Rubber buffer	Anneau caoutchouc	3
10	10	10	471 8641-01	Plug	Fiche	3
11	2	2	471 2441-06	Bracket	Pièce de retenue	3
12	12	12	471 7864-01	Clip	Colliers de serrage	3 M6
13	2	2	438 5335-01	Guide	Guide	3
14	1	1	471 8158-02	Gasket	Joint	1 L=1415
15	1	1	471 2440-35	Strip	Ruban	1
16	1	1		Detergent container	Compartiment à savon	1,2 See group 8802
17	1	1	432 0630-01	Support	Support	3
18	1	1	438 5326-01	Bracket	Support de montage	3 Left
19	1	1	438 0151-01	Bracket	Support de montage	3 Right
20	1	1	432 0916-01	Top panel	Couvercle	1
			432 0916-02	Top panel	Couvercle	1 With coin meter
21	1	1	432 0933-01	Brace	Montant	3
22	1	1	762 1209-10	Grommet	Oeillet	3
23	1	1	762 1191-10	Grommet	Oeillet	3
24	1	1	432 1127-01	Mounting plate	Plaque de montage	3
25	1	1	471 9550-14	Transformer	Transformateur	1 200V T1
			471 9550-19	Transformer	Transformateur	1 346,380,440,480V T1
26	1	1	432 0550-04	Cable set	Jeu de câbles	3

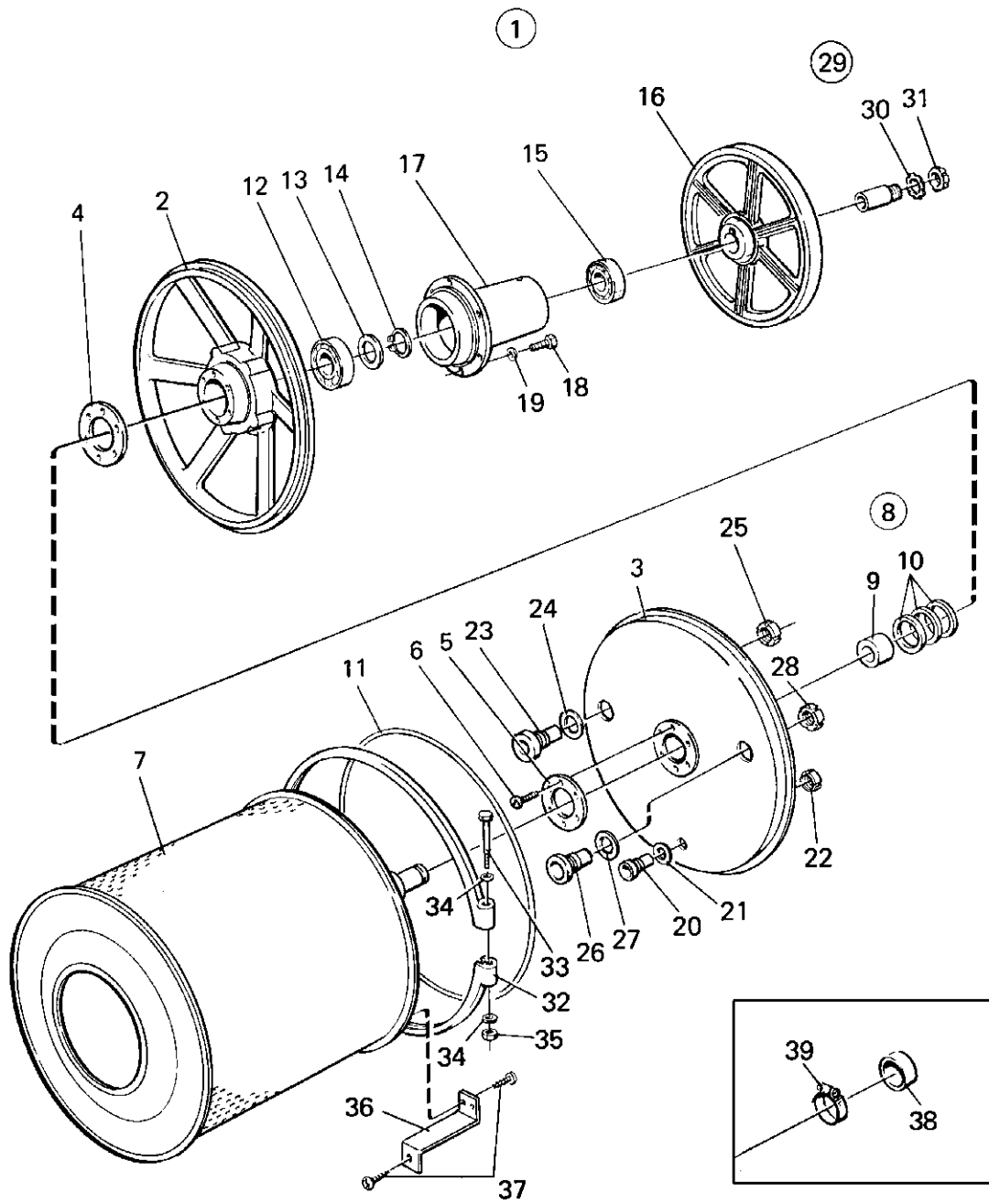

101690

Issue	Month	Year
02	11	03

EXSM 230C,EXSM 230S

Back plate with inner drum, bearing, pulley

Illustration Issue Month Year
Schéma Issue Month Year
101690/2 2 8 1999

Pignon arrière avec tambour intérieur, palier, poulie

Item Article	Qua. Qua.	Art.No Réf. article	Description	Description	Info Info	Notes Remarques
1	1	438 4426-02	Back plate	Pignon arrière	1	
2	1	471 2439-04	•Back plate	•Pignon arrière	3	
3	1	471 4417-01	•Plate	•Plaque	3	Stainless steel
4	1	471 2574-02	•Gasket	•Joint	3	
5	1	471 2440-89	•Washer	•Rondelle	3	
6	6	471 8311-00	•Screw	•Vis	3	M6SFTT 5X16
7	1	471 4447-02	•Inner drum	•Intérieur du tambour	1	
8	1	472 9902-11	•Repair kit	•Kit reconditionnement	1,2	
9	1		••Bushing	••Douille		
10	3		••Sealing ring	••Bague d'étanchéité		
11	1		••Rubber strip	••Joint caoutchouc		
12	1		••Ball bearing	••Roulement à billes		
13	1		••Ring	••Anneau		
14	1		••C-clamp	••Presse à main		SGA 60
15	1		••Ball bearing	••Roulement à billes		
16	1	438 4420-20	•Pulley	•Poulie	1	
17	1	438 4176-02	•Bearing housing	•Logement de palier	3	
18	6	725 2634-71	•Screw	•Vis	3	M16X60
19	6	734 1186-01	•Washer	•Rondelle	3	BRB 17X30
20	1	438 0456-01	•Nipple	•Raccord	1	
21	1	471 2440-10	•Gasket	•Joint	1	
22	1	438 0457-01	•Nut	•Écrou	1	
23	1	438 0458-01	•Nipple	•Raccord	1	
24	1	471 2440-12	•Gasket	•Joint	1	
25	1	438 0459-01	•Nut	•Écrou	1	
26	1	438 4101-01	•Nipple	•Raccord	1	
27	1	471 2441-44	•Gasket	•Joint	1	
28	1	438 4100-01	•Nut	•Écrou	1	
29	1	471 8551-02	•Sleeve	•Manchon	1	
30	1	471 8512-01	••Lock washer	••Rondelle d'arrêt	1	
31	1	471 8402-01	••Nut	••Écrou	1	
32	2	471 2439-73	•Tension strap	•Extenseur	3	
33	2	471 9222-59	•Screw	•Vis	3	M8X140
34	4	471 8502-14	•Washer	•Rondelle	3	BRB 8,4X17
35	2	732 2118-01	•Locking nut	•Contre-écrou	3	M8
36	1	438 4193-01	Bracket	Support	3	
37	4	725 2366-61	Screw	Vis	3	M6SF 6X12
38	1	471 2416-83	Hood	Capot	3	
39	1	736 2825-51	Hose clamp	Attache flexible	3	Ø32

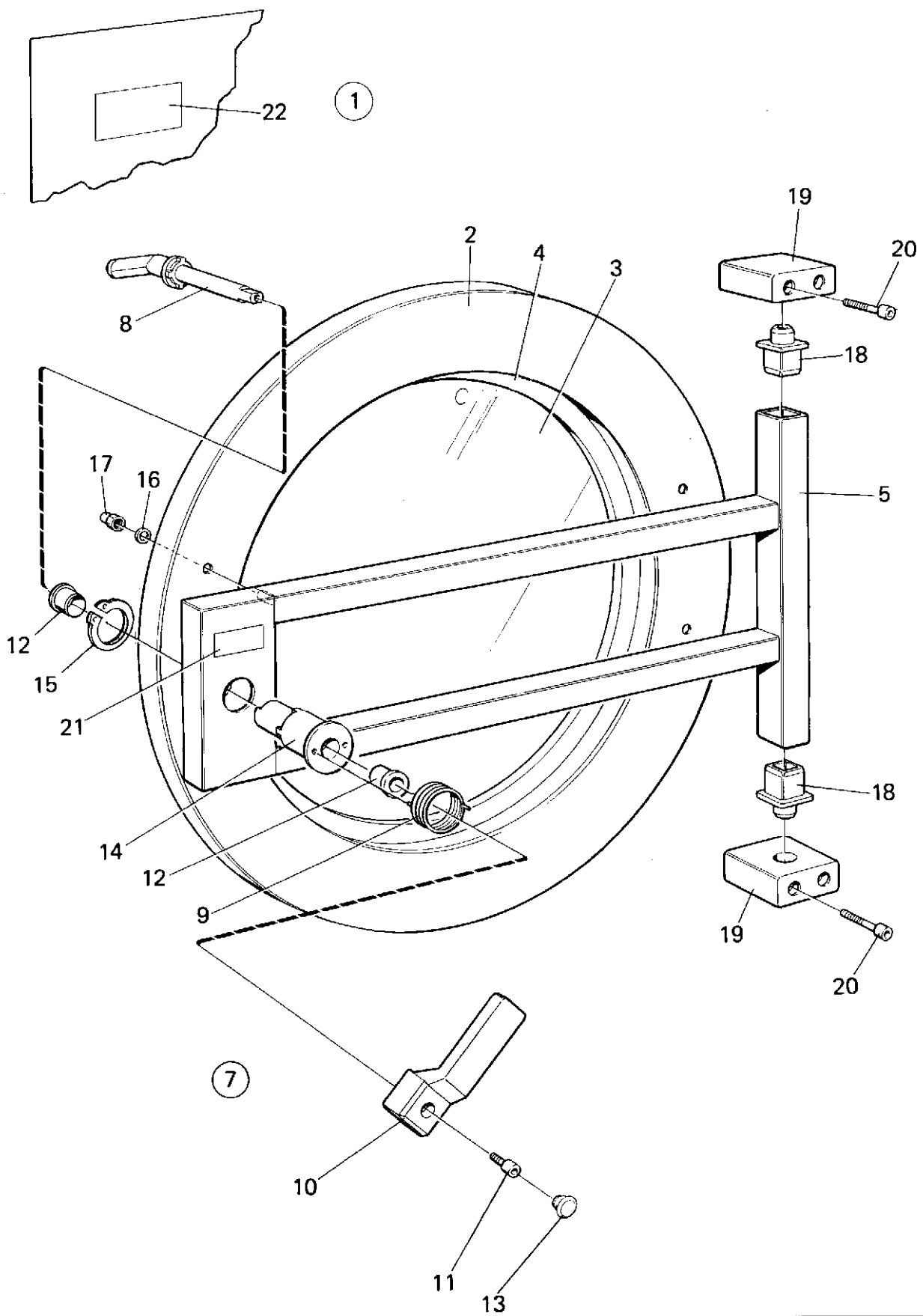

EXSM 230C,EXSM 230S

Door and hinged joint

Assemblage articulé et plaque

Illustration Issue Month Year
Schéma Issue Month Year
101689/1 2 4 2001

Item Article	Qua. Qua.	Art.No Réf. article	Description	Description	Info Info	Notes Remarques
1	1	438 4326-11	Door	Plaque	1	Complete
	1	438 4326-12	Door	Plaque	1	Aqua clean Complete
2	1	438 4130-01	•Door ring	•Anneau de la porte	3	
3	1	471 2431-28	•Door glass	•Vitre de la porte	1,2	
	1	438 4219-01	•Door glass	•Vitre de la porte	1,2	Aqua clean
4	1	471 2431-29	•Door gasket	•Joint de la porte	1,2	Black
5	1	438 4117-01	•Bracket	•Pupitre	3	
6						NOT USED
7	1	472 9903-43	••Door handle	••Poignée de la porte	1,2	Kit
8	1	438 0422-01	•••Shaft	•••Arbre	3	
9	1	471 7814-02	•••Spring	•••Ressort	3	
10	1	438 4127-02	•••Handle	•••Poignée	1,2	
11	1	471 8341-85	•••Screw	•••Vis	3	M6X16
12	2	438 0033-01	•••Bushing	•••Douille	3	
13	1	471 7961-02	•••Plug	•••Fiche	3	
14	1	438 4126-02	•••Hub	•••Moyeu	1	
15	1	735 3126-01	•••Circlip	•••Attache en forme C	3	
16	4	734 1153-09	••Washer	••Rondelle	3	BRB 6,4X12
17	4	732 3116-14	••Nut	••Écrou	3	M6
18	1	438 4132-02	••Pin	••Goupille	3	
19	2	438 4128-01	Hinged joint	Assemblage articulé	3	
20	4	471 8341-50	Screw	Vis	3	MRT 6X50
21	1	471 7674-01	Sign	Signe	3	
22	1	471 7668-01	Warning sign	Signal avertissement	3	Swedish
	1	471 7668-02	Warning sign	Signal avertissement	3	English
	1	471 7668-03	Warning sign	Signal avertissement	3	German
	1	471 7668-04	Warning sign	Signal avertissement	3	French
	1	471 7668-05	Warning sign	Signal avertissement	3	Italian
	1	471 7668-06	Warning sign	Signal avertissement	3	Norwegian
	1	471 7668-07	Warning sign	Signal avertissement	3	Finnish
	1	471 7668-08	Warning sign	Signal avertissement	3	Danish
	1	471 7668-09	Warning sign	Signal avertissement	3	Spanish
	1	471 7668-10	Warning sign	Signal avertissement	3	Dutch
	1	471 7668-11	Warning sign	Signal avertissement	3	Polish
	1	471 7668-12	Warning sign	Signal avertissement	3	CZECISH
	1	471 7668-13	Warning sign	Signal avertissement	3	Russian

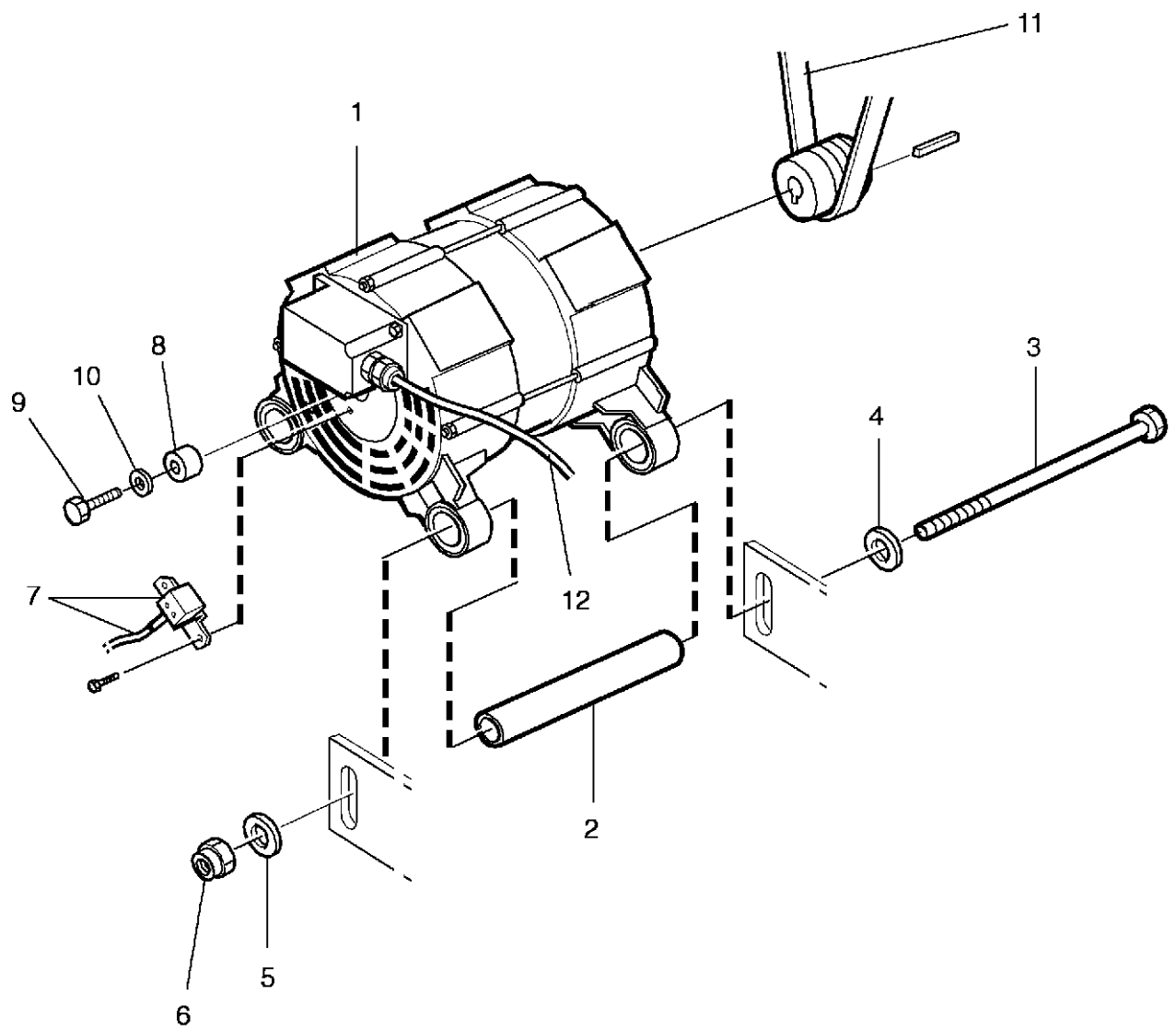

EXSM 230C,EXSM 230C -06230/4601,EXSM 230S

Motor and motor suspension

Illustration Issue Month Year
Schéma Issue Month Year
101692/2 4 9 2002

Purgeur et flexible

Item Article	Qua. Qua.	Art.No Réf. article	Description	Description	Info Info	Notes Remarques
1	1	471 9741-03	Motor	Moteur	1,2	
2	2	432 0641-02	Pipe	Tube	3	
3	2	471 8356-06	Screw	Vis	3	M12x260
4	2	471 8502-10	Washer	Rondelle	3	12x35
5	2	734 1178-01	Washer	Rondelle	3	BRB 13X24
6	2	732 2122-01	Locking nut	Contre-écrou	3	M12
7	1	432 0550-40	Cable	Câble	1,2	With sensor
8	1	471 9578-50	Magnet	Aimant	3	
9	1	725 2453-51	Screw	Vis	3	M8X25
10	1	734 1164-01	Washer	Rondelle	3	8,4X17
11	1	471 7711-05	V-belt	Courroie trapézoïdale	1,2	
12	1	432 0550-46	Cable set	Jeu de câbles	3	

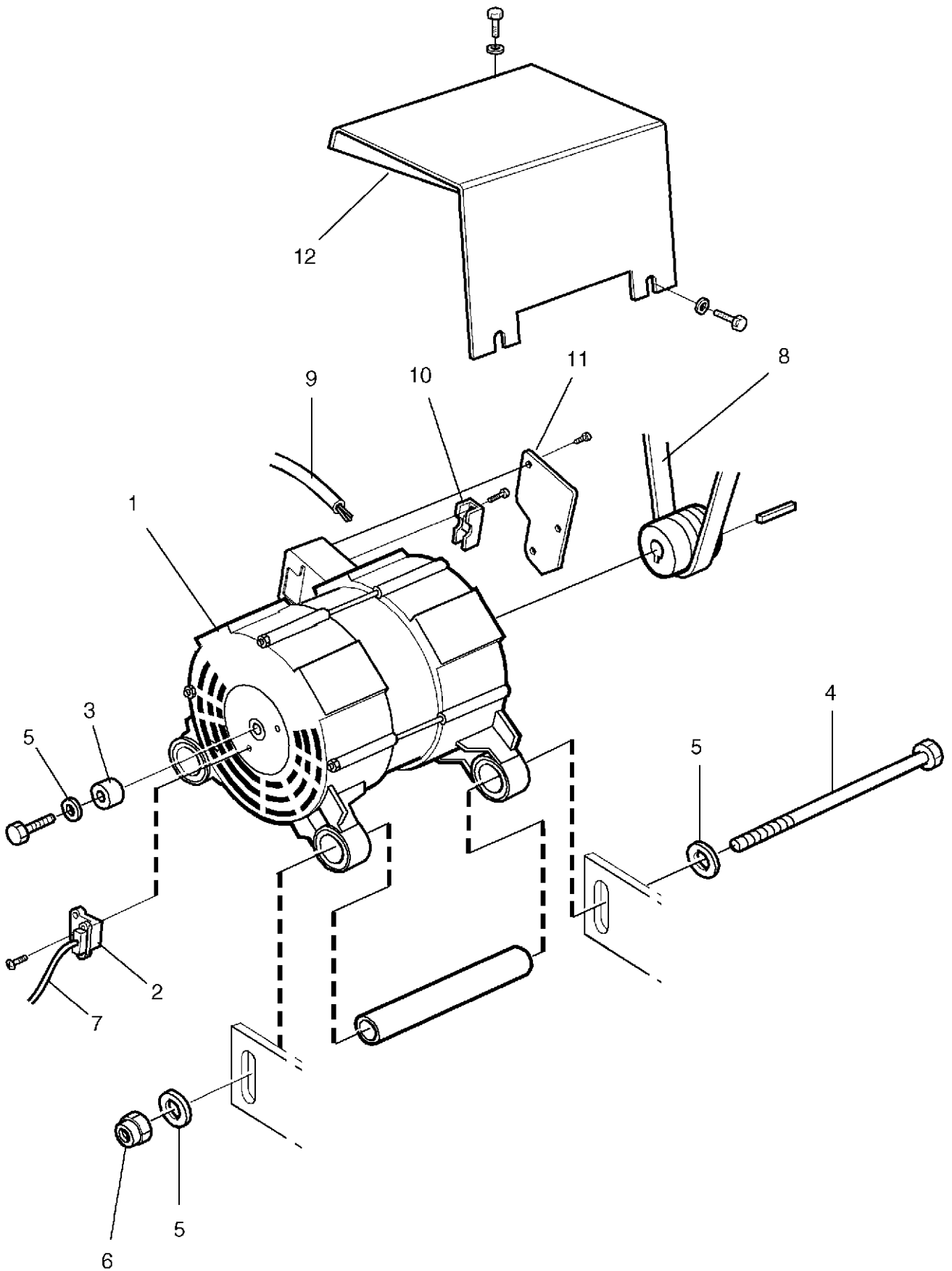

EXSM 230C,EXSM 230C 06230/4602-,EXSM 230S

Motor and motor suspension

Purgeur et flexible

Illustration Issue Month Year
Schéma Issue Month Year
102189/1 2 2 2003

Item Article	Qua. Qua.	Art.No Réf. article	Description	Description	Info Info	Notes Remarques
1	1	471 9741-04	Motor	Moteur	1,2	
2	1	432 3901-01	•Sensor/transducer	•Capteur	1,2	
3	1	432 3905-01	•Magnet	•Aimant	3	
4	2	471 8356-06	Screw	Vis	3	M12x260
5	4	471 8502-10	Washer	Rondelle	3	12x35
6	2	732 2122-01	Locking nut	Contre-écrou	3	M12
7	1	432 0549-48	Cable set	Jeu de câbles	1,2	
8	1	471 7711-05	V-belt	Courroie trapézoïdale	1,2	
9	1	432 0549-47	Cable set	Jeu de câbles	3	
10	1	438 9799-02	Clamp	Attache	3	
11	1	438 9799-03	Cover	Couvercle	3	
12	1	432 0936-01	Drip guard	Lèche-goutte	3	

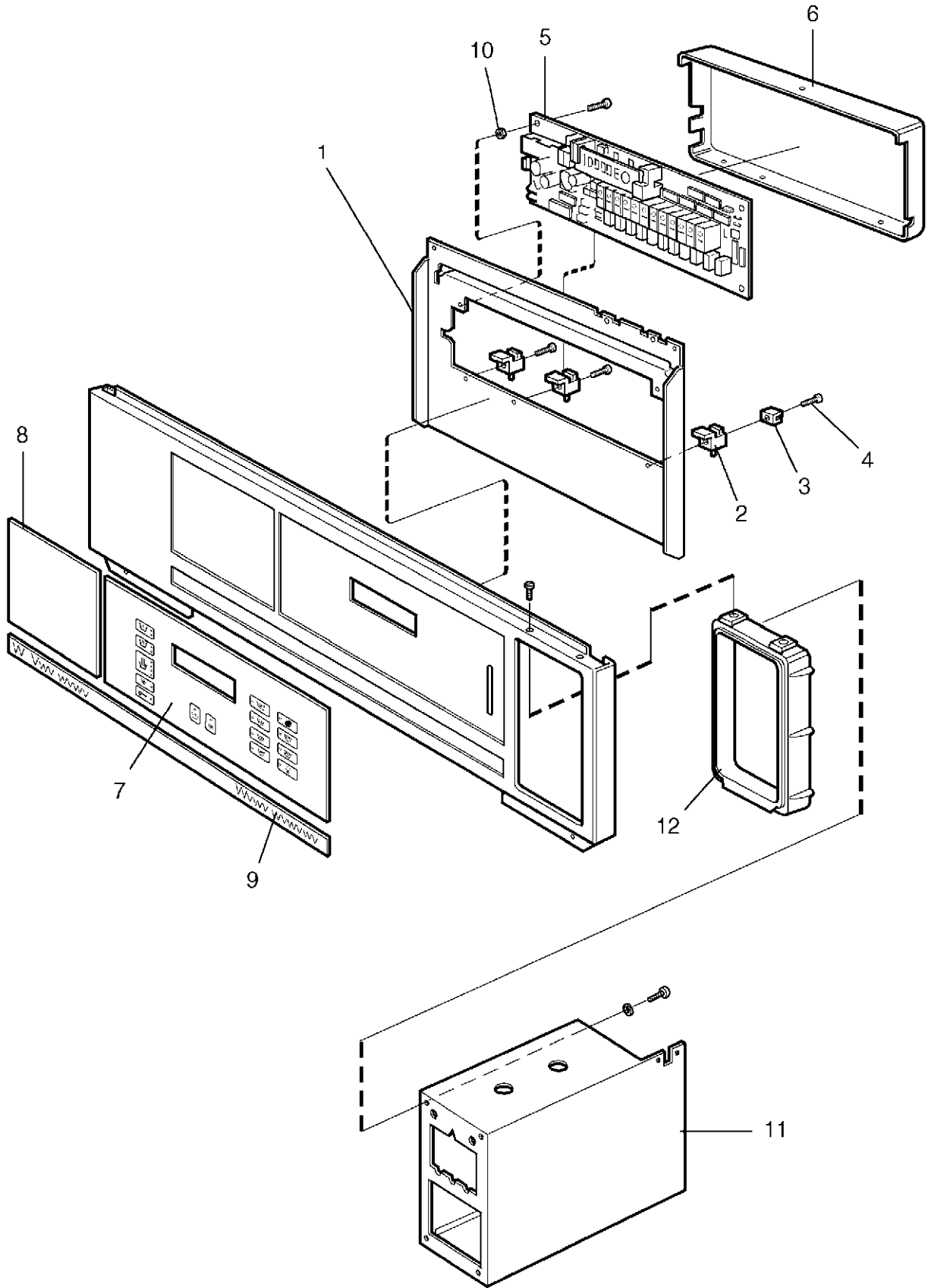

EXSM 230S

Control panel

Pupitre de commande

Illustration Issue Month Year
Schéma Issue Month Year
102190/1 1 9 2002

Item Article	Qua. Qua.	Art.No Réf. article	Description	Description	Info Info	Notes Remarques
1	1	432 0927-01	Mounting plate	Plaque de montage	3	
2	3	438 5154-01	Bracket	Pièce de retenue	3	
3	3	471 9004-75	Bracket	Support de montage	3	
4	3	471 8340-26	Screw	Vis	3	4,2x25
* 5	1	471 8988-04	Printed circuit board	Circuit imprimé	1,2	
6	1	438 5341-01	Safety lid	Couvercle protection	3	
7	1	472 5763-09	Panel sign	Voyant du tableau	1,2	SE06
8	1	471 7694-42	Instruction plate	Plaque instruction utilisation	1,2	SE06
9	1	471 7716-13	Type plate	Numéro série plaque	3	
10	2	471 8410-01	Nut	Écrou	3	
11	1	438 4088-01	Coin box	Boite à jetons	3	
12	1	471 4705-02	Frame	Châssis	3	

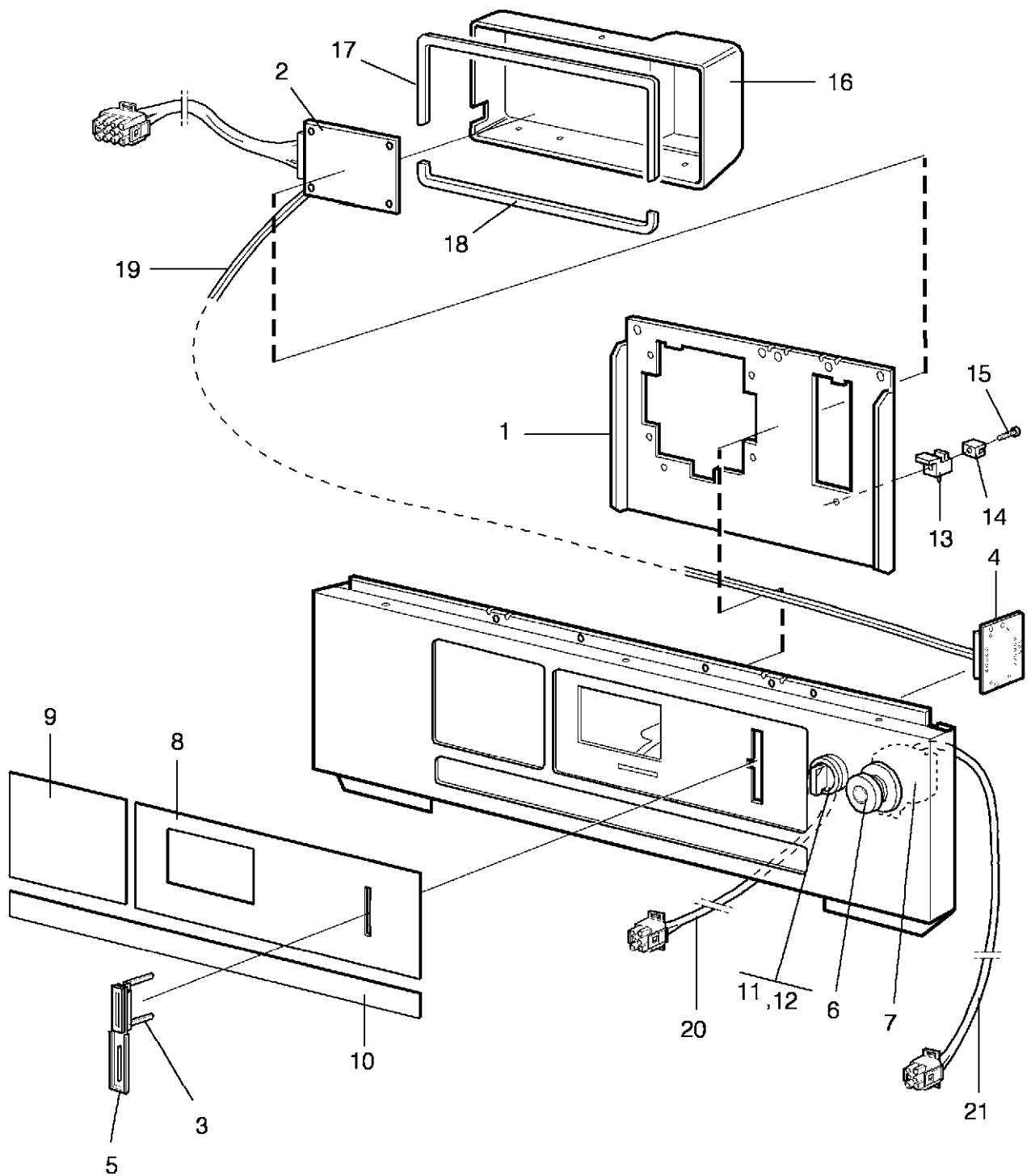

EXSM 230C

Control panel

Pupitre de commande

Illustration Issue Month Year
Schéma Issue Month Year
101694/2 4 4 2001

Item Article	Qua. Qua.	Art.No Réf. article	Description	Description	Info Info	Notes Remarques
1	1	432 0928-01	Mounting plate	Plaque de montage	3	
2	1	471 8997-02	Display	Ecran de contrôle	1,2	
3	1	432 0150-01	Bracket	Pièce de retenue	3	
4	1	471 8793-01	Card reader	Lecteur de carte	1	
5	1	432 0149-01	Rubber cap	Capuchon caoutchouc	3	
6	1	471 9628-22	Emergency stop	Arrêt d'urgence	1	-99/3438
	1	471 9628-32	Emergency stop	Arrêt d'urgence	1	99/3439-
7	1	471 9628-90	Socket	Bloc de connexion	1	-99/3438
	1	471 9628-33	Contact block	Bloc de connexion	1	99/3439-
8	1	472 5775-01	Panel sign	Voyant du tableau	1,2	
9	1	471 7694-46	Sign	Échelle	1,2	
10	1	471 7716-14	Type plate	Numéro série plaque	3	EXSM230C
11	1	471 9628-20	Control button	Bouton de commande	1	
12	1	471 9628-99	Anti-rotation ring	Anneau antirotation	3	
13	2	438 5154-01	Bracket	Pièce de retenue	3	
14	2	471 9004-75	Bracket	Support de montage	3	
15	2	471 8340-26	Screw	Vis	3	4,2x25 4,2x25
16	1	432 0538-01	Heat shield	Bouclier thermique	3	
17						Not used
18						Not used
19	1	432 0550-11	Cable set	Jeu de câbles	3	
20	1	432 0550-66	Cable set	Jeu de câbles	3	EI/DS
21	1	432 0550-87	Cable set	Jeu de câbles	3	Emergency stop

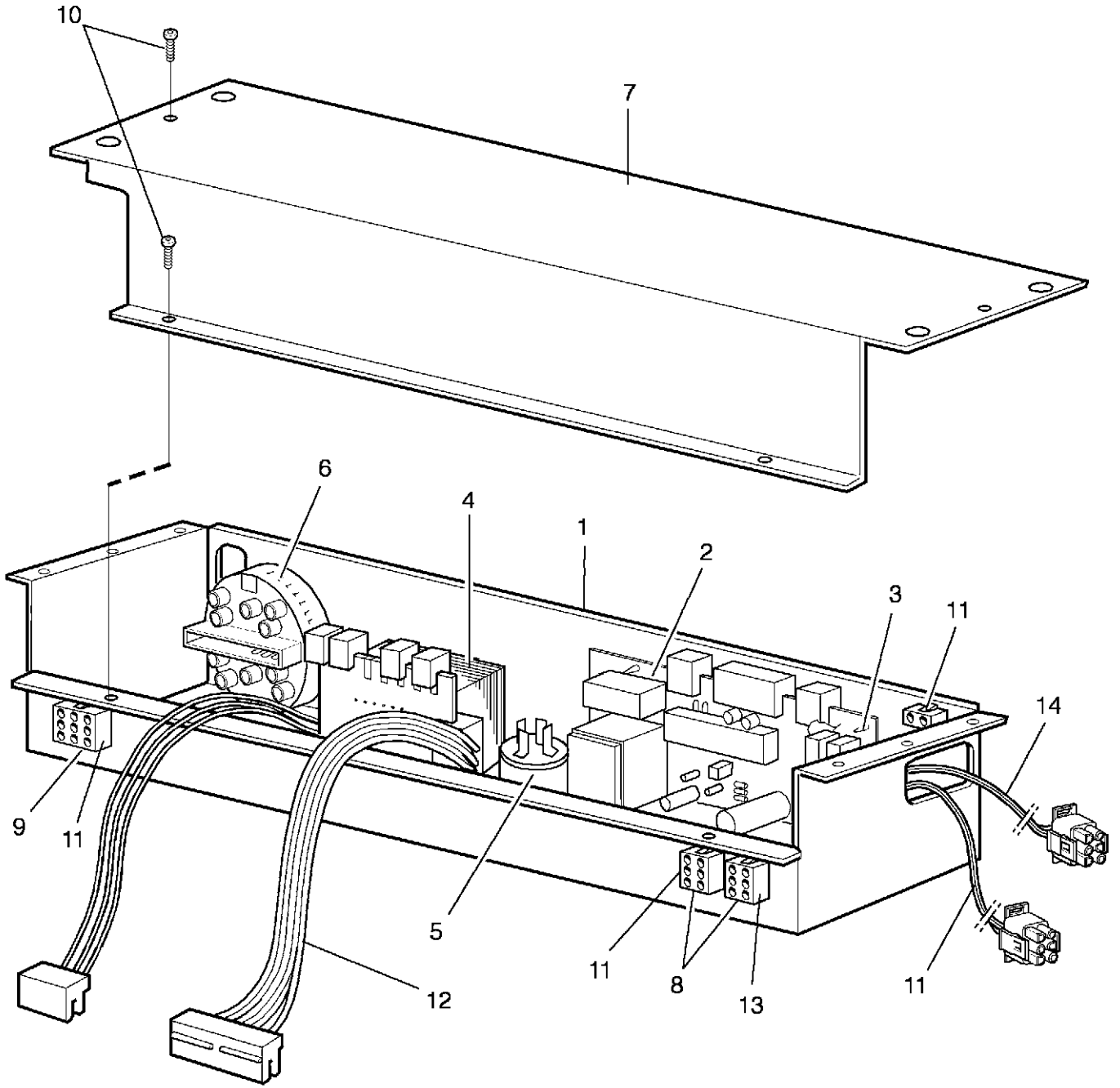

EXSM 230S

Control unit

Unité de contrôle

Illustration Issue Month Year
Schéma Issue Month Year
101634/3 2 7 2000

Item Article	Qua. Qua.	Art.No Réf. article	Description	Description	Info Info	Notes Remarques
1	1	432 0635-01	Component panel	Panneau composants	3	
2	1	438 9555-01	Printed circuit board	Circuit imprimé	1,2	Door lock
3	4	471 7958-01	Support	Support	3	
4	1	471 9558-11	Transformer	Transformateur	1	
5	1	471 9529-10	Mains filter	Filtre de filet	1	208-240V
6	1	471 8859-06	Level control	Réglage de niveau	1	
7	1	432 0636-01	Cover	Couvercle	3	
8	2	762 3211-01	Plug connector	Connexion enfichable	3	6-pole
9	1	762 3231-01	Plug connector	Connexion enfichable	3	9-POLE
10	4	471 8342-13	Screw	Vis	3	MRT-TT 4X10
11	1	432 0550-20	Cable set	Jeu de câbles	3	
12	1	432 3087-11	Cable set	Jeu de câbles	3	
13	1	432 0550-16	Cable set	Jeu de câbles	3	X11
14	1	432 0550-15	Cable set	Jeu de câbles	3	X20

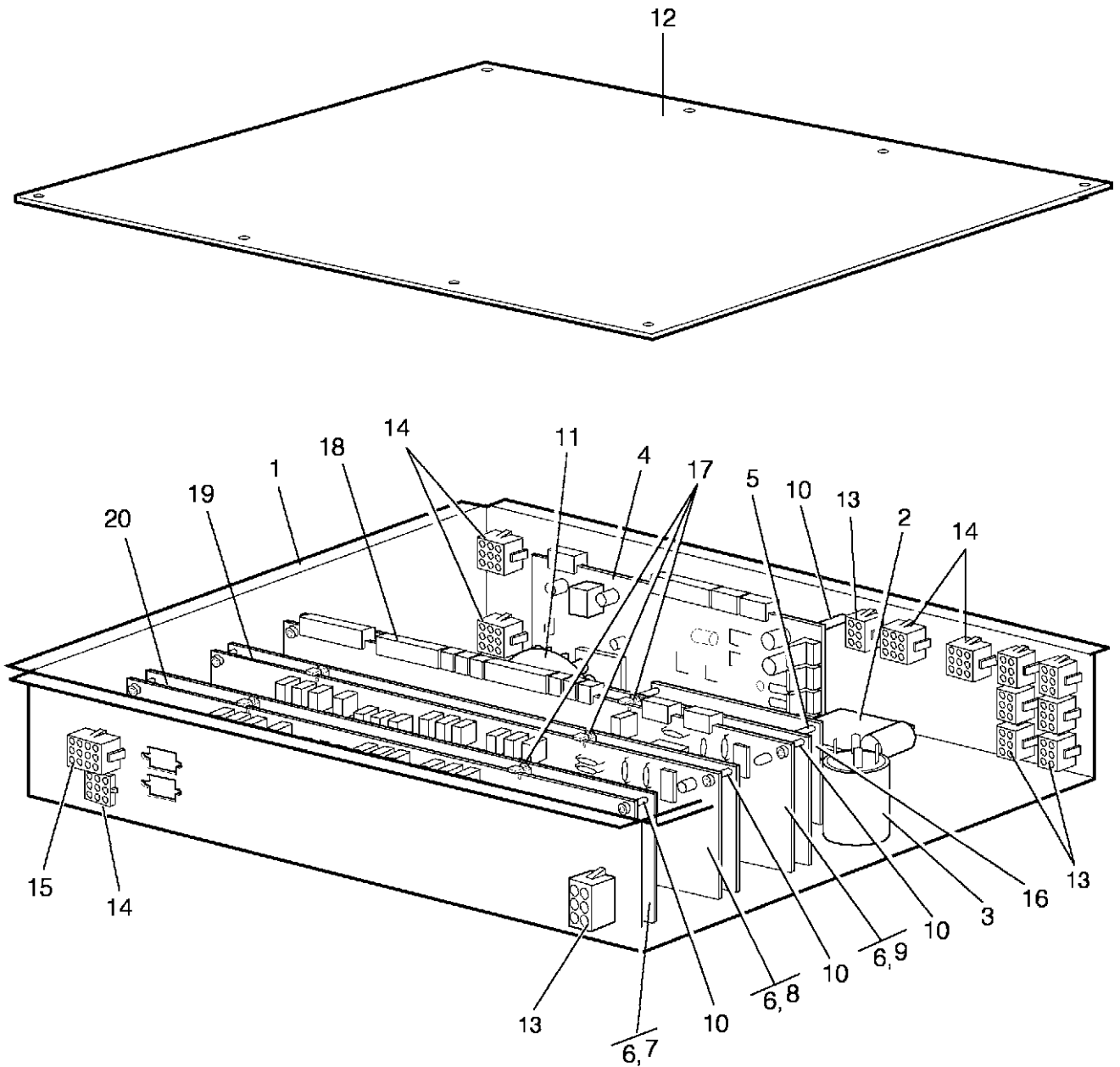

EXSM 230C

Control unit

Unité de contrôle

Illustration Issue Month Year
Schéma Issue Month Year
101635/2 3 9 2002

Item Article	Qua. Qua.	Art.No Réf. article	Description	Description	Info Info	Notes Remarques
1	1	432 0632-01	Component panel	Panneau composants	3	
	1	432 0632-02	Component panel	Panneau composants	3	
2	1	471 8792-01	Transformer	Transformateur	1	
3	1	471 9529-10	Mains filter	Filtre de filet	1	208-240V
4	1	471 8993-01	Printed circuit board	Circuit imprimé	1	Not configured CPU-card
	1	432 0808-01	Printed circuit board	Circuit imprimé	1	I/O card, HW USA
	1	432 0808-02	Printed circuit board	Circuit imprimé	1	2 I/O card, DS USA
	1	432 0808-03	Printed circuit board	Circuit imprimé	1	1 I/O card, DS USA
	1	432 0808-04	Printed circuit board	Circuit imprimé	1,2	1 I/O card, HW Spanish
5	4	471 7958-01	Support	Support	3	
6	RQ	432 0142-01	Bracket	Support de montage	3	I/O-card
7	1	471 8995-01	Printed circuit board	Circuit imprimé	1	I/O-card Configured Not configured
	1	471 8995-03	Printed circuit board	Circuit imprimé	1	I/O-card A5
8	1	471 8995-01	Printed circuit board	Circuit imprimé	1	I/O-card Configured Not configured
	1	471 8995-02	Printed circuit board	Circuit imprimé	1	I/O-card Configured A4
9	1	471 8995-01	Printed circuit board	Circuit imprimé	1	I/O-card Configured A3
10	RQ	438 0299-01	Spacer	Entretoise	3	
11	1	471 8859-06	Level control	Réglage de niveau	1	
12	1	432 0633-01	Cover	Couvercle	3	
13	7	762 3211-01	Plug connector	Connexion enfichable	3	6-pole
14	4	762 3231-01	Plug connector	Connexion enfichable	3	9-POLE
15	1	762 3251-01	Plug connector	Connexion enfichable	3	12-POLE
16	1	438 9555-01	Printed circuit board	Circuit imprimé	1,2	Door lock
17	RQ	471 7958-02	Support	Support	3	
18	1	432 0550-10	Cable set	Jeu de câbles	3	1 I/O card
19	1	432 0550-12	Cable set	Jeu de câbles	3	2 I/O card
20	1	432 0550-13	Cable set	Jeu de câbles	3	3 I/O card

1

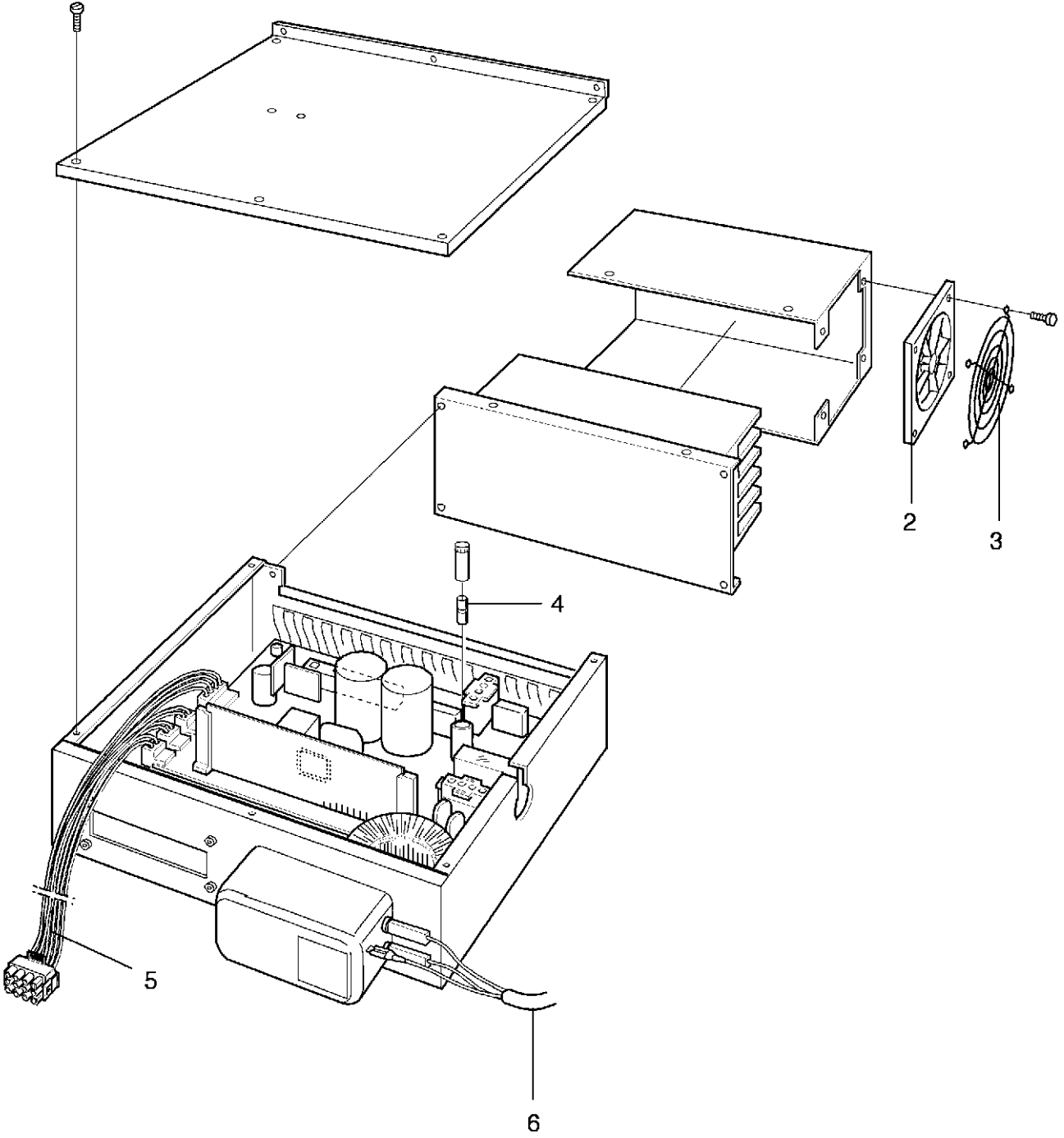

EXSM 230C,EXSM 230S

Motor control

Contrôle du moteur

Illustration	Issue	Month	Year
Schéma	Issue	Month	Year
101625/7	3	9	2002

Item Article	Quantity Quantité	Art.No Réf. article	Description	Description	Info Info	Notes Remarques
			EXSM 230S			
			EXSM 230C			
1	1	1	471 9771-01	Motor control		Compl.
2	1	1	471 9773-01	•Fan	1	
3	1	1	471 9774-02	•Fan grill	3	
4	1	1	471 8750-22	•Fuse	1,2	1,6A
5	1	1	432 0550-43	Cable set	3	Clarus EWD
6	1	1	432 0549-06	Cable set	3	Transformer
	1	1	432 0549-07	Cable set	3	

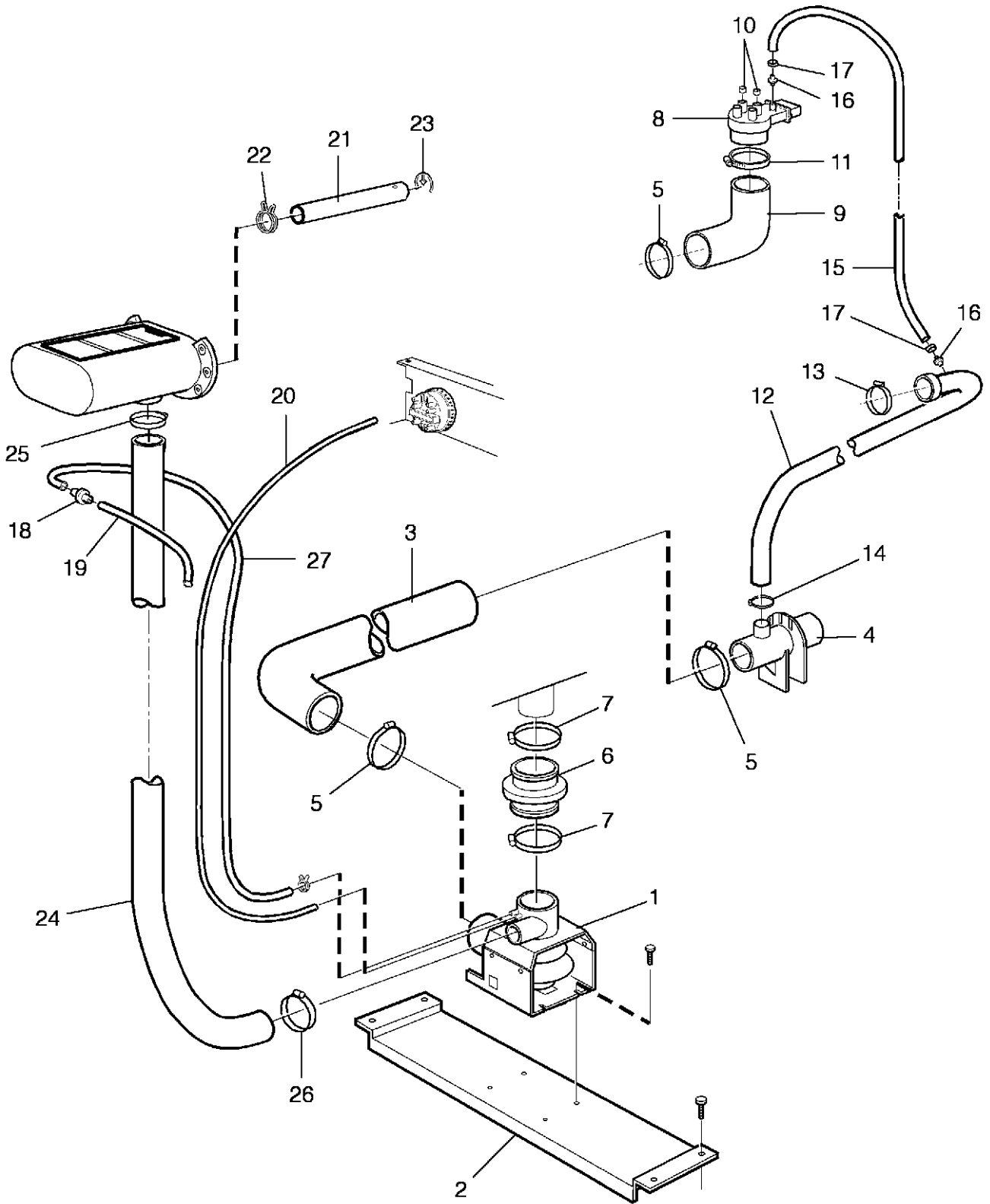

EXSM 230C,EXSM 230S

Drain valve and hoses

Purgeur et flexible

Illustration Issue Month Year
Schéma Issue Month Year
101695/1 2 4 2003

Item Article	Quantity Quantité	Art.No Réf. article	Description	Description	Info Info	Notes Remarques
			EXSM 230S			
			EXSM 230C			
1	1	472 8754-13	Drain valve	Purgeur	1,2	Group 81
2	1	432 0923-01	Brace	Montant	3	
* 3	1	471 4835-01	Drain hose	Flexible de vidange	1,2	Ø75
4	1	438 0084-03	Drain pipe connection	Raccord de vidange	3	
5	3	736 2846-51	Hose clamp	Attache flexible	3	Ø73-83
6	1	471 2904-01	Connection	Flexible caoutchouc	3	
7	2	471 7851-03	Hose clamp	Attache flexible	3	Ø95-115
8	1	471 4516-03	Air inlet	Prise d'air	3	
9	1	471 4437-01	Hose	Flexible	1,2	
10	2	471 8175-01	Plug	Fiche	3	
11	1	736 2849-51	Hose clamp	Attache flexible	3	Ø77-93
12	1	471 4403-02	Hose	Flexible	1,2	
13	1	736 2840-51	Hose clamp	Attache flexible	3	Ø50-63
14	1	736 2831-51	Hose clamp	Attache flexible	3	Ø36-42
15	1	471 2449-72	Hose	Flexible	1	L=940
16	2	471 2432-25	Hose nipple	Mamelon de flexible	3	
17	2	736 2816-51	Hose clamp	Attache flexible	3	Ø13-19
18	1	471 4651-24	Nipple	Raccord	3	
19	1	471 2433-14	Hose	Flexible	1,2	L=940 7,5x4x940
20	1	471 2425-28	Hose	Flexible	1,2	L=1500
21	1	438 0145-08	Hose	Flexible	3	L=510
22	1	736 2825-51	Hose clamp	Attache flexible	3	Ø32
23	1	438 0127-01	Lock	Serrure	3	
24	1	471 4427-01	Hose	Flexible	3	
25	1	736 2840-51	Hose clamp	Attache flexible	3	Ø50-63
26	1	736 2837-51	Hose clamp	Attache flexible	3	Ø48-54
27	1	471 5103-05	Hose	Flexible	1,2	

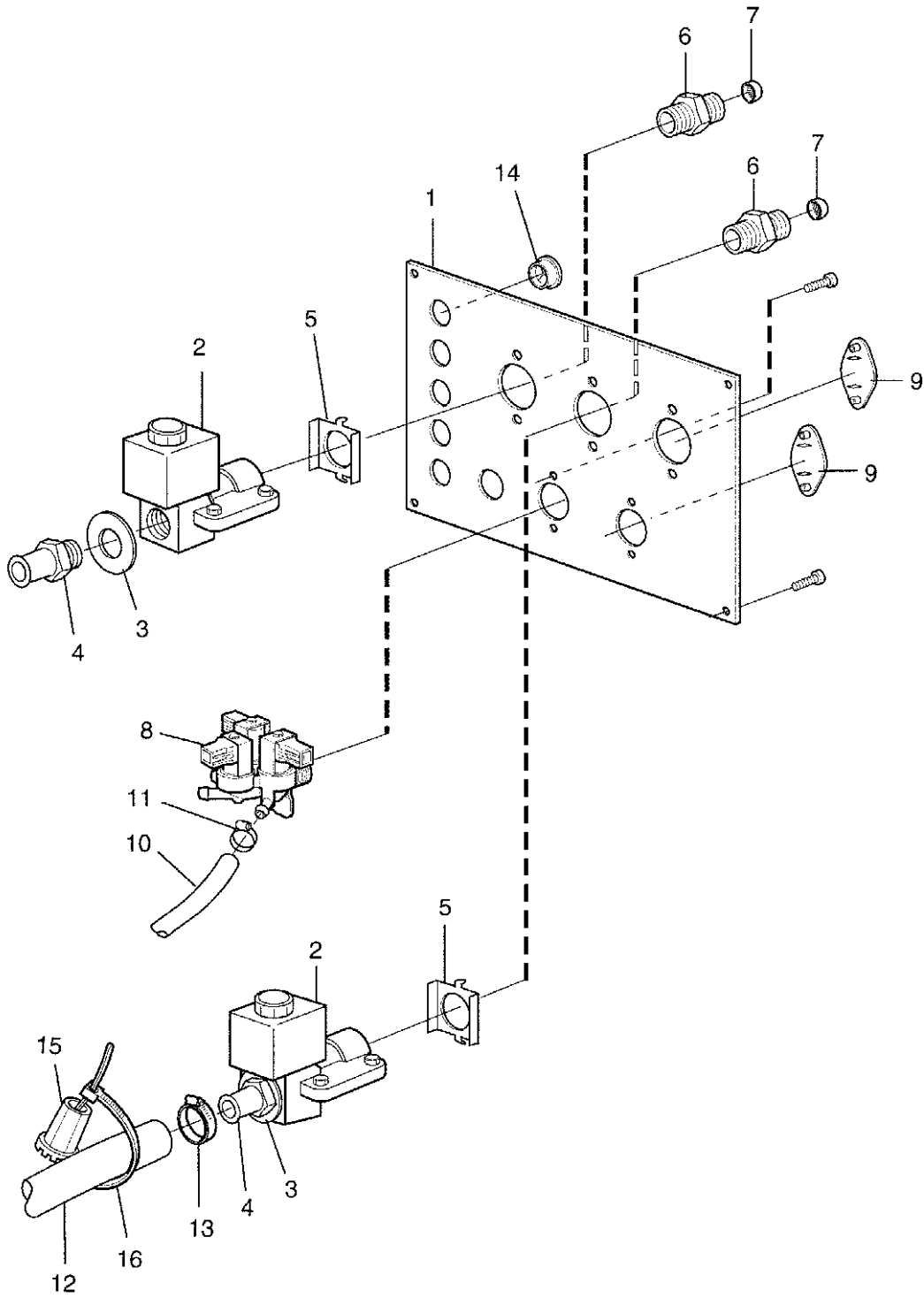

EXSM 230C,EXSM 230S

Water connections

Raccords d'eau

Illustration Issue Month Year
Schéma Issue Month Year
101696/1 4 3 2001

Item Article	Quantity Quantité	Art.No Réf. article	Description	Description	Info Info	Notes Remarques
			EXSM 230S			
			EXSM 230C			
1	1	432 0629-01	Mounting plate	Plaque de montage	3	
2	2	471 8210-63	Valve	Soupape	1,2	60Hz See group 8125
3	2	471 8159-06	Gasket	Joint	3	
4	2	471 8623-01	Connection	Embrayage	3	1/2"
5	2	471 2937-01	Bracket	Support	3	
6	2	471 8693-12	Nipple	Raccord	3	1/2"-3/4"
7	2	471 8693-21	Filter	Filtre	3	
8	1	471 8236-65	Valve	Soupape	1,2	EPDM 2, 240V 60Hz 3-way See group 8117
9	RQ	472 6761-01	Cover washer	Rondelle protection	3	
10	RQ	877 5211-08	Hose	Flexible	1	Per 1 m
11	3	736 2816-51	Hose clamp	Attache flexible	3	Ø13-19
12	2	432 1129-01	Hose	Flexible	1	
13	2	736 2825-51	Hose clamp	Attache flexible	3	Ø32
14	5	471 7977-01	Bushing	Douille	3	
15	1	471 4792-01	Tool	Outil	3	
16	1	762 9105-05	Cable strap	Serre-câble	3	
17	1	432 0549-99	Cable set	Jeu de câbles	3	Gen 5 Cold/hot water Not illustrated
		432 0549-79	Cable set	Jeu de câbles	3	Clarus Cold/hot water Not illustrated

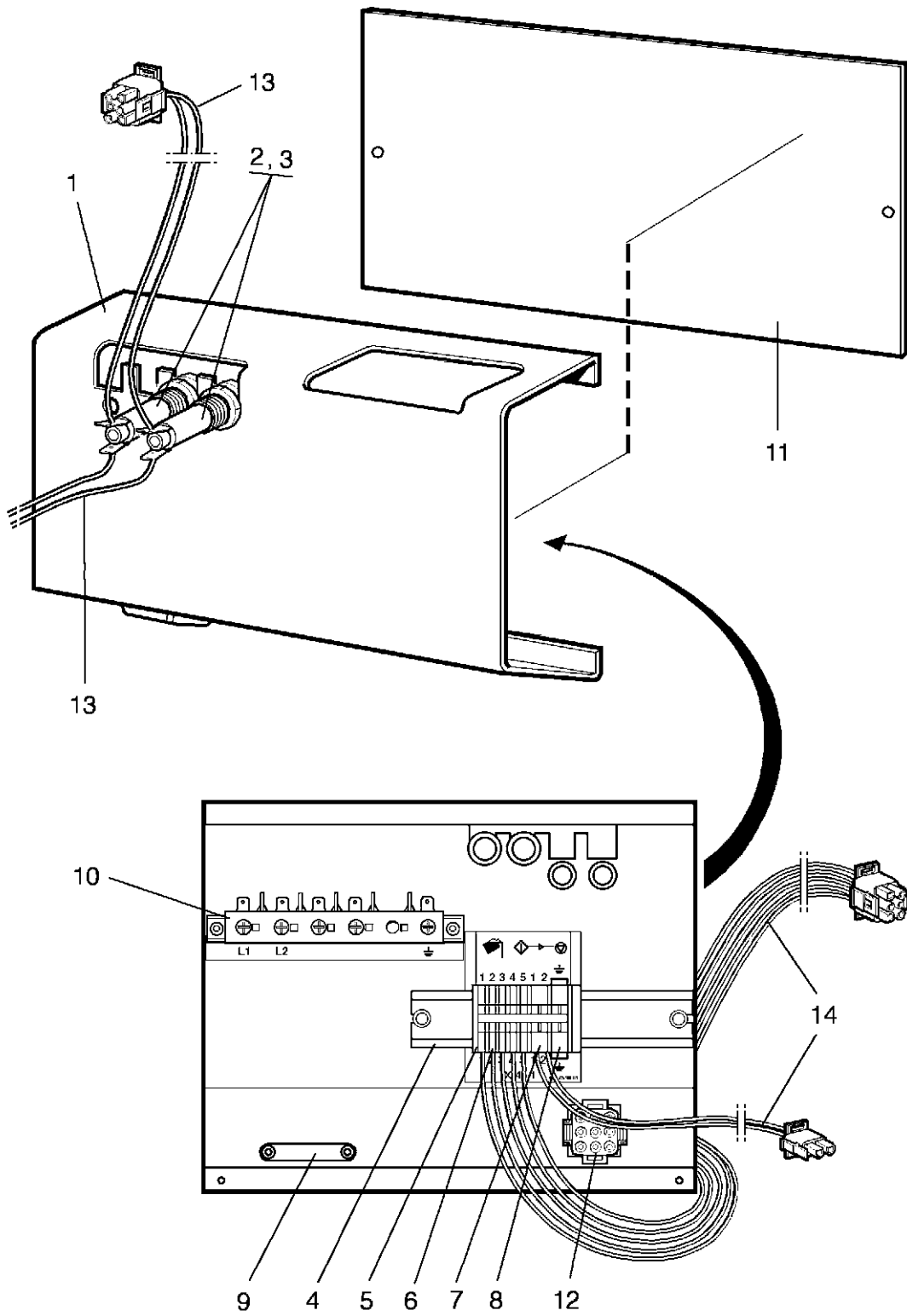

EXSM 230S

Electric components

Composants électriques

Illustration Issue Month Year
Schéma Issue Month Year
101698/4 3 11 2000

Item Article	Qua. Qua.	Art.No Réf. article	Description	Description	Info Info	Notes Remarques
1	1	432 0631-01	Mounting plate	Plaque de montage	3	
2	2	471 8750-11	Fuse	Porte-fusible	1,2	1,25A 5X20MM
3	2	471 8756-51	Insert	Insertion	1,2	5X20MM
4	1	471 7182-23	Rail	Support	3	
5	6	471 8781-11	Block	Cale	3	
6	RQ	471 8781-02	Block	Cale	3	Orange
7	RQ	471 8781-01	Block	Cale	3	Grey
8	RQ	471 8781-03	Block	Cale	3	Yellow/Green
9	1	471 7859-11	Clamp	Attache	3	
	1	471 7859-16	Clamp	Attache	3	Upper part
10	1	471 8759-01	Block	Cale	3	
11	1	432 1125-01	Cover	Couvercle	3	
12	1	762 3231-01	Plug connector	Connexion enfichable	3	9-POLE
13	1	432 0549-01	Cable set	Jeu de câbles	3	
14	1	432 0549-99	Cable set	Jeu de câbles	3	Gen 5 Cold/hot water

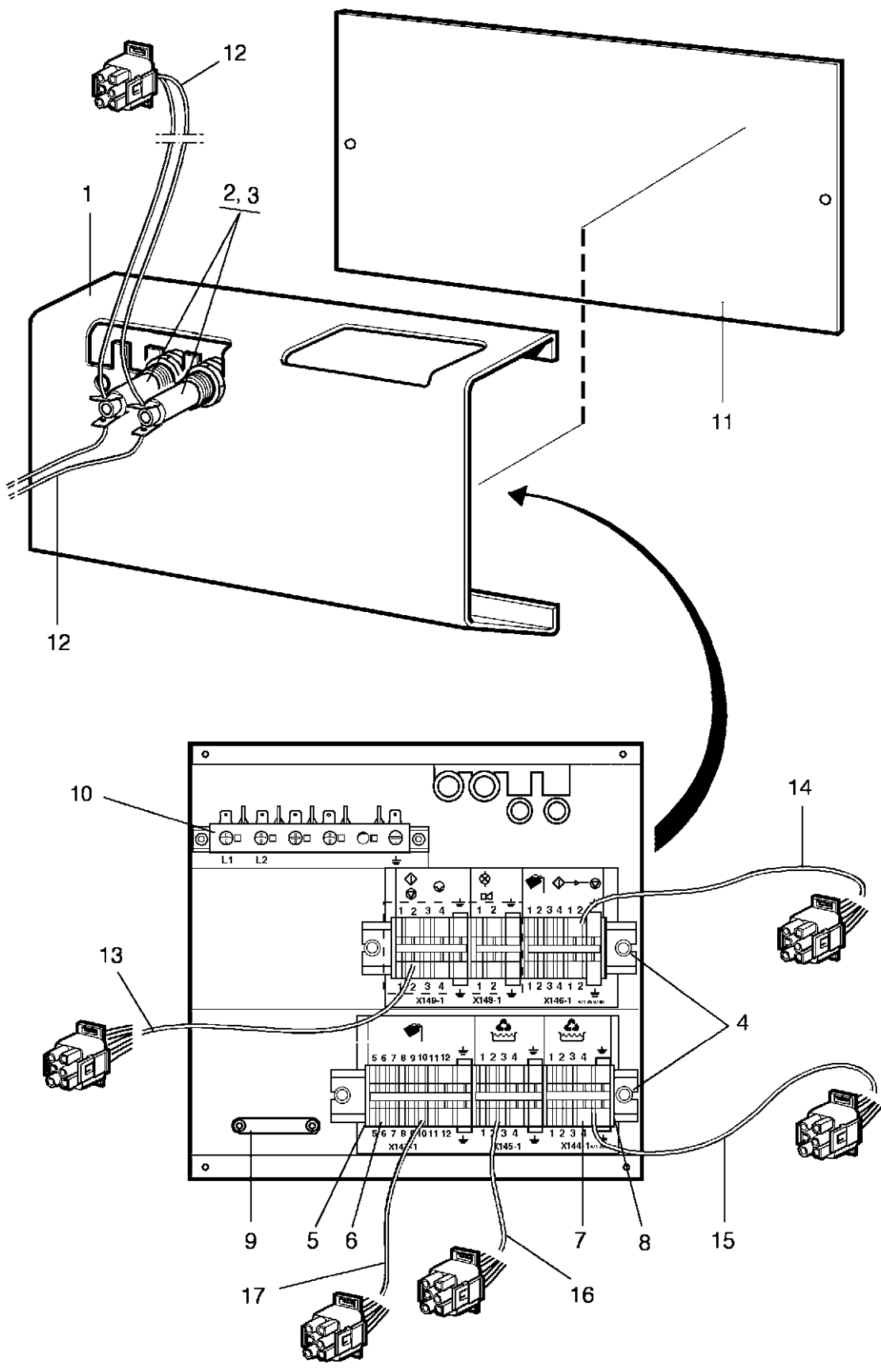

Issue	Month	Year
03	06	00

EXSM 230C

Electric components

Composants électriques

Illustration Issue Month Year
Schéma Issue Month Year
101691/3 3 11 2000

Item Article	Qua. Qua.	Art.No Réf. article	Description	Description	Info Info	Notes Remarques
1	1	432 0631-01	Mounting plate	Plaque de montage	3	
2	2	471 8750-11	Fuse	Porte-fusible	1,2	1,25A 5X20MM
3	2	471 8756-51	Insert	Insertion	1,2	5X20MM
4	2	471 7182-23	Rail	Support	3	
5	6	471 8781-11	Block	Cale	3	
6	RQ	471 8781-02	Block	Cale	3	Orange
7	RQ	471 8781-01	Block	Cale	3	Grey
8	RQ	471 8781-03	Block	Cale	3	Yellow/Green
9	1	471 7859-11	Clamp	Attache	3	
	1	471 7859-16	Clamp	Attache	3	Upper part
10	1	471 8759-01	Block	Cale	3	
11	1	432 0639-01	Cover	Couvercle	3	
12	1	432 0549-01	Cable set	Jeu de câbles	3	
13	1	432 0550-98	Cable set	Jeu de câbles	3	
14	1	432 0550-95	Cable set	Jeu de câbles	3	
15	1	432 0550-35	Cable set	Jeu de câbles	3	
16	1	432 0550-36	Cable set	Jeu de câbles	3	
17	1	432 0550-96	Cable set	Jeu de câbles	3	

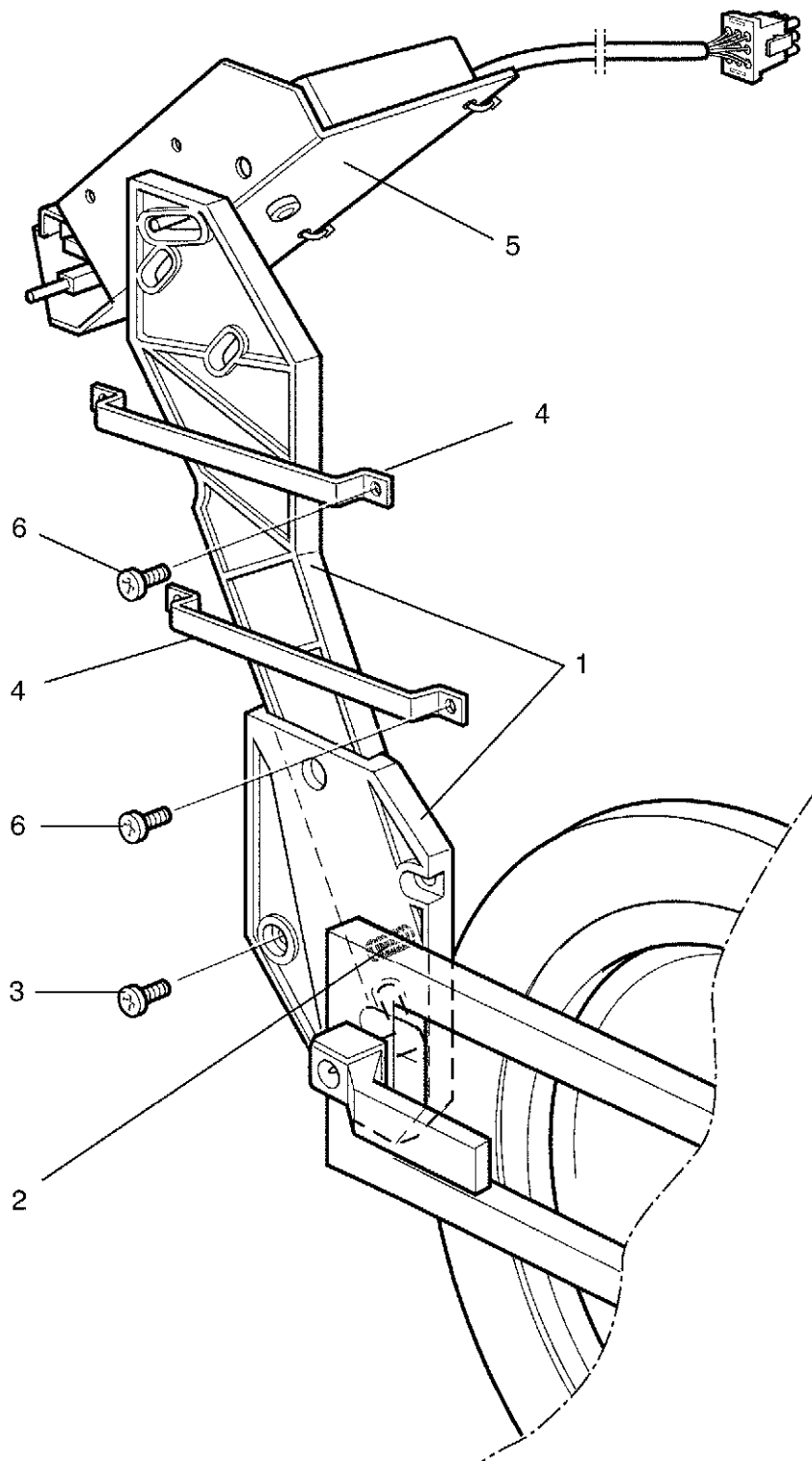

Issue	Month	Year
01	03	99

EXSM 230C,EXSM 230S

Door locking system

Serrure de porte

Illustration Issue Month Year
Schéma Issue Month Year
101686/1 1 3 1999

Item Article	Qua. Qua.	Art.No Réf. article	Description	Description	Info Info	Notes Remarques
1	1	472 9901-33	Arm and plate	Bras et tableau	1	Kit compl
2	1	471 7803-21	Spring	Ressort	3	
3	4	471 8342-44	Screw	Vis	3	MRT-TT 6X12
4	2	472 9187-01	Clamp	Bride de fixation	3	
5	1		Door locking device	Serrure de porte	1,2	
6	4	471 8342-11	Screw	Vis	3	MRT-TT 4X6

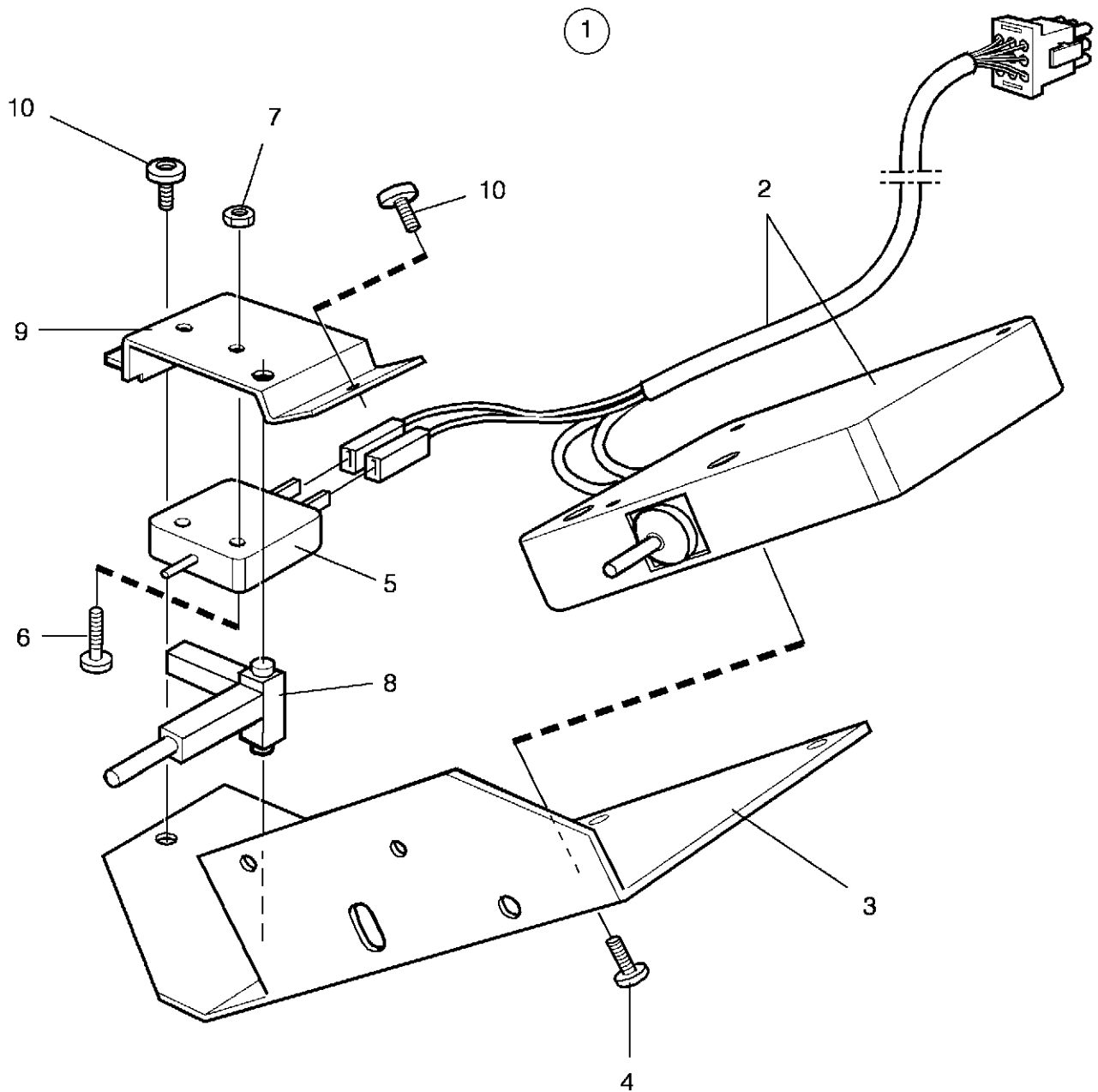

EXSM 230C,EXSM 230S

Door locking device

Serrure de porte

Illustration Issue Month Year
Schéma Issue Month Year
101687/2 3 7 2000

Item Article	Qua. Qua.	Art.No Réf. article	Description	Description	Info Info	Notes Remarques
1	1	432 0555-02	Door locking device	Serrure de porte	1,2	
2	1	432 0550-22	•Actuator	•Actuator	1,2	With cablage
3	1	432 0925-01	•Mounting plate	•Plaque de montage	3	
4	2	471 8341-24	•Screw	•Vis	3	M5X12
5	1	471 9654-03	•Microswitch	•Microrupteur	1,2	
6	2	471 8341-17	•Screw	•Vis	3	M4X25
7	2	732 2112-01	•Locking nut	•Contre-écrou	3	M4
8	1	438 4149-01	•Rocker arm	•Lever basculant	3	
9	1	432 0926-01	•Mounting plate	•Plaque de montage	3	
10	2	471 8342-11	•Screw	•Vis	3	MRT-TT 4X6

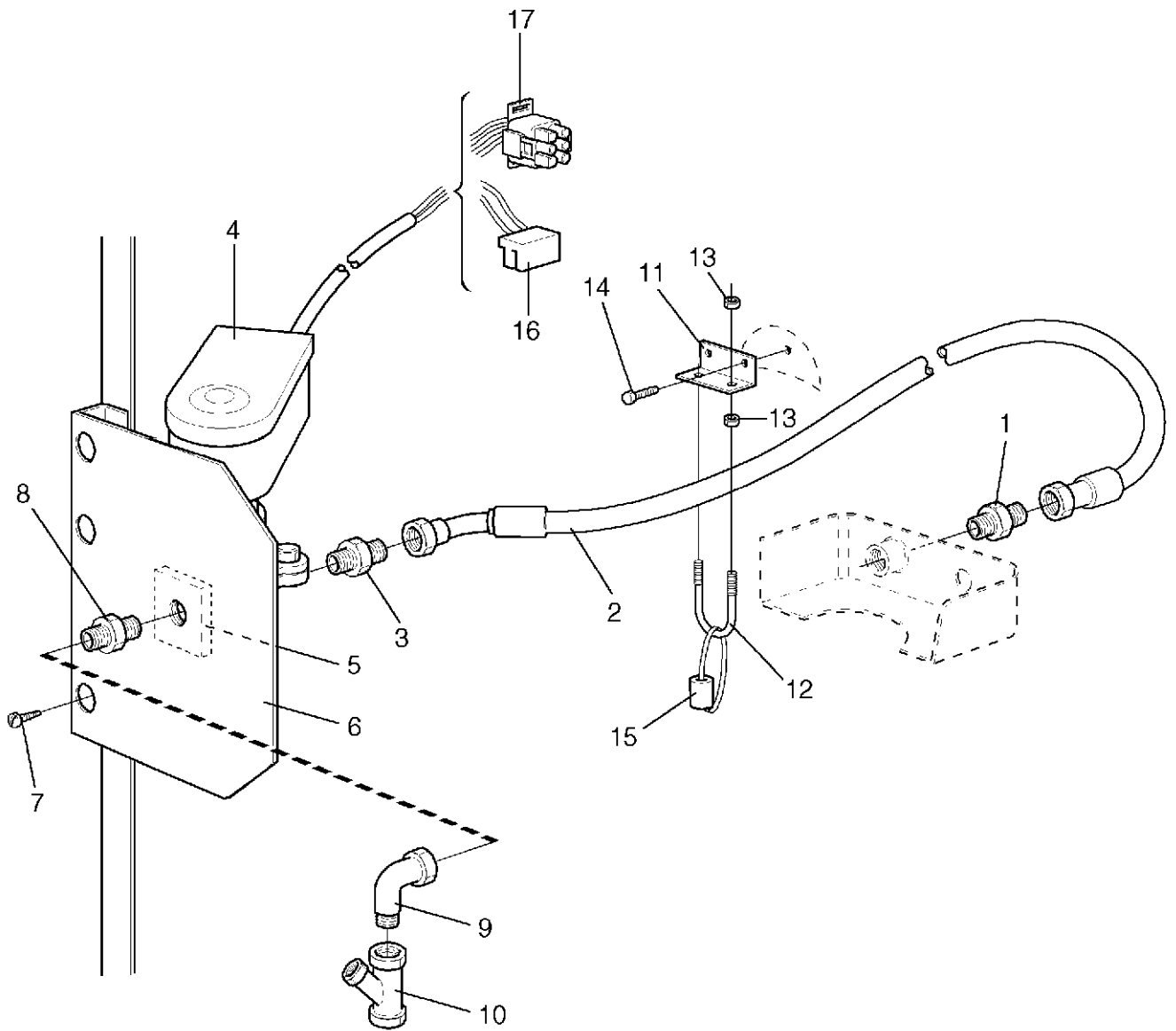

EXSM 230C,EXSM 230S

Steam components

Illustration Issue Month Year
Schéma Issue Month Year
101797/1 2 8 2001

Composants

Item Article	Qua. Qua.	Art.No Réf. article	Description	Description	Info Info	Notes Remarques
1	1	438 0168-02	Steam injector	Injecteur de vapeur	1	
2	1	471 8126-18	Hose	Flexible	1,2	L=650
3	1	471 8670-03	Nipple	Raccord	3	
4	1	471 8279-03	Valve	Soupape	1,2	50/60 Hz
	1	471 8279-08	•Repair kit	•Kit de réparation	1,2	
5	1	471 2937-01	Bracket	Support	3	
6	1	438 0167-01	Plate	Plaque	3	
7	3	471 8340-23	Screw	Vis	3	RTS 4,2X13
8	1	471 8622-01	Nipple	Raccord	3	1/2"-3/4" 50Hz
10	1	744 3115-06	Filter	Filtre	3	R 3/4"
11	1	438 0330-01	Bracket	Support de montage	3	
12	1	471 8308-07	Clamp	Bride de fixation	3	
13	4	731 2318-01	Nut	Écrou	3	M8
14	2	725 2366-61	Screw	Vis	3	M6SF 6X12
15	1	438 0341-02	Washer	Rondelle	1	
16	1	432 0549-61	Cable set	Jeu de câbles	3	Exacta
17	1	432 0549-63	Cable set	Jeu de câbles	3	Clarus

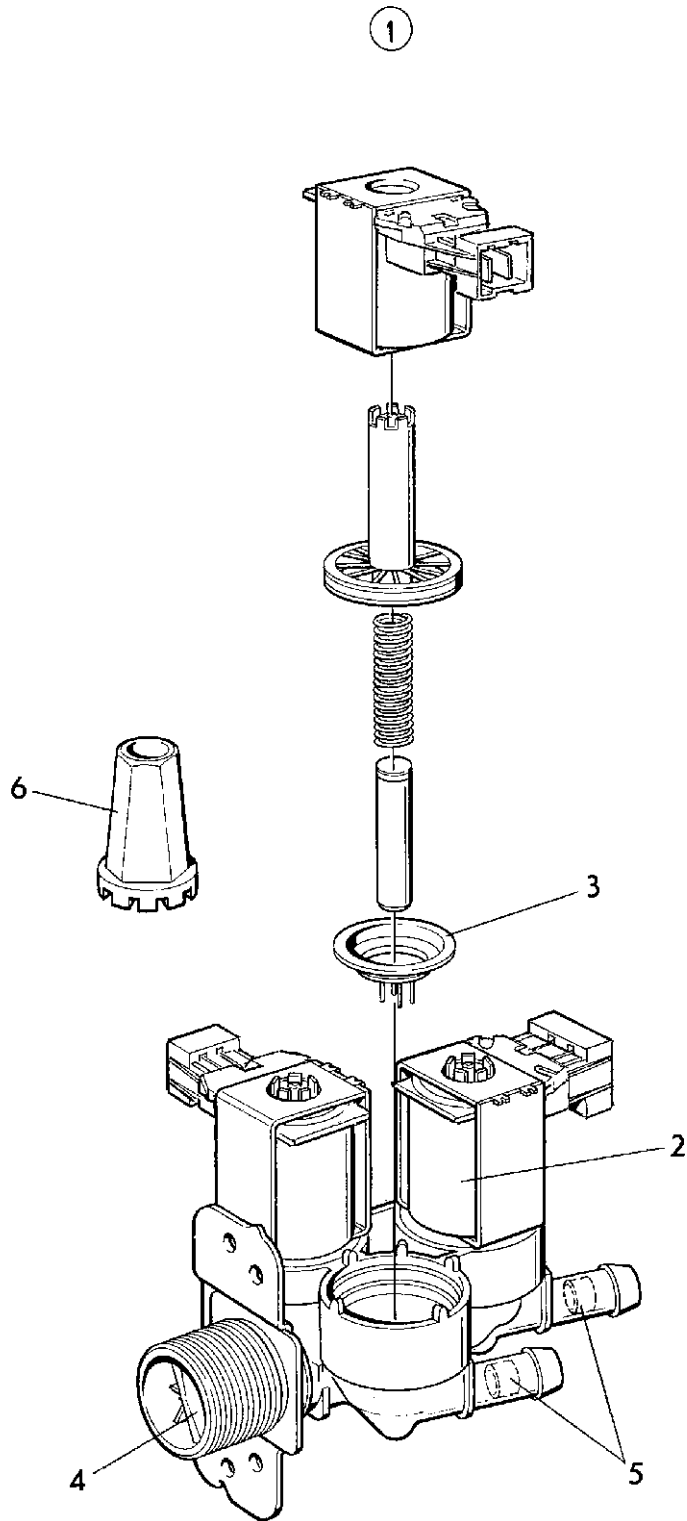

EXSM 230C,EXSM 230S

Inlet valve 3/4", 3-way

Soupape de admission 3/4", 3 voies

Illustration Issue Month Year
Schéma Issue Month Year
100797/1 7 10 2002

Item Article	Qua. Qua.	Art.No Réf. article	Description	Description	Info Info	Notes Remarques
1	1	471 8236-52	Valve	Soupape	1,2	208-240V Restriction 5,5/-/1/min
	1	471 8236-56	Valve	Soupape	1,2	208-240V
	1	471 8236-60	Valve	Soupape	1,2	208-240V Restriction 5,5/10/10 l/min
	1	471 8236-62	Valve	Soupape	1,2	208-240V Restriction 5,5/8/8 l/min
	1	471 8236-64	Valve	Soupape	1,2	208-240V Restriction -/5,5 l/min
	1	471 8236-57	Valve	Soupape	1,2	208-240V
	1	471 8236-68	Valve	Soupape	1,2	208-240V IN 20L/MIN,OUT 2, 5L/MIN
	1	471 8236-66	Valve	Soupape	1,2	EPDM 2, 120V 60Hz 3-way
	1	471 8236-65	Valve	Soupape	1,2	EPDM 2, 240V 60Hz 3-way
2	1	471 6860-15	•Coil	•Bobine	1,2	120V Green
	1	471 6860-16	•Coil	•Bobine	1,2	120V Orange
	1	471 6860-17	•Coil	•Bobine	1,2	120V White
	1	471 6860-18	•Coil	•Bobine	1,2	Green
	1	471 6860-19	•Coil	•Bobine	1,2	Orange
	1	471 6860-20	•Coil	•Bobine	1,2	White
3	1	471 8234-98	•Diaphragm	•Diaphragme	1,2	NITRIL
	1	471 8234-92	•Diaphragm	•Diaphragme	1,2	EPDM USA
4	1	471 8234-94	•Filter	•Filtre	1	
5	1	471 8234-95	•Restrictor	•Réducteur de débit	3	2,5l/min
	1	471 8234-96	•Restrictor	•Réducteur de débit	3	5,5l/min
6	1	471 4792-01	Tool	Outil	3	

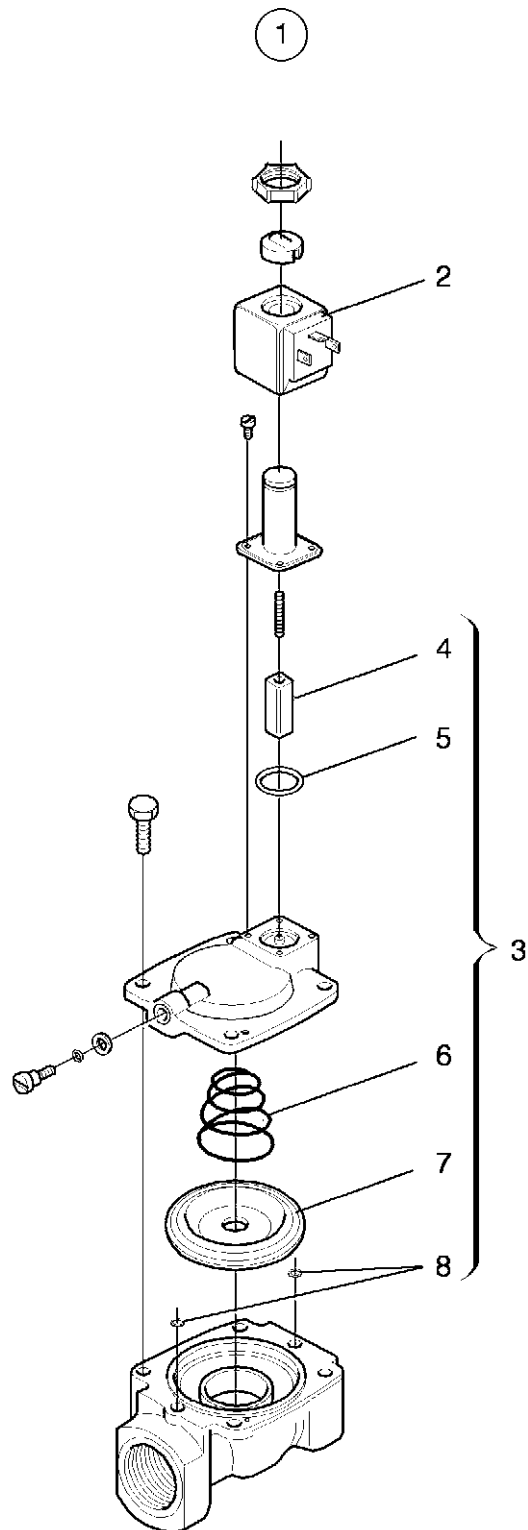

EXSM 230C,EXSM 230S

Inlet valve 1/2", 3/4", 1", 1 1/4", 2"

Soupape de admission 1/2", 3/4", 1", 1 1/4", 2"

Illustration	Issue	Month	Year
Schéma	Issue	Month	Year
100568	4	3	2003

Item Article	Qua. Qua.	Art.No Réf. article	Description	Description	Info Info	Notes Remarques
1	1	471 8210-02	Valve	Soupape	1,2	1/2" 220-240V 50Hz Complete
	1	471 8210-01	Valve	Soupape	1,2	1/2" 208-230V 60Hz Complete
	1	471 8210-03	Valve	Soupape	1,2	1/2" 115V 60Hz Complete
	1	471 8210-12	Valve	Soupape	1,2	3/4" 220-240V 50Hz Complete
	1	471 8210-11	Valve	Soupape	1,2	3/4" 208-230V 60Hz Complete
	1	471 8210-22	Valve	Soupape	1,2	1" 220-240V 50Hz Complete
	1	471 8210-21	Valve	Soupape	1,2	1" 208-230V 60Hz Complete
	1	471 8210-32	Valve	Soupape	1,2	1 1/4" 50Hz Complete
	1	471 8210-31	Valve	Soupape	1,2	1 1/4" 60Hz Complete
	1	471 8210-52	Valve	Soupape	1,2	2", 50Hz Complete
	1	471 8210-51	Valve	Soupape	1,2	2", 60Hz Complete
2	1	471 6657-15	•Coil	•Bobine	1,2	50Hz 220-240V 50Hz
	1	471 6657-16	•Coil	•Bobine	1,2	60Hz
	1	471 6657-17	•Coil	•Bobine	1,2	115V 60Hz
3	1	471 6657-18	•Repair kit	•Kit reconditionnement	1,2	1/2"
	1	471 6657-19	•Repair kit	•Kit reconditionnement	1,2	3/4"
	1	471 6657-20	•Repair kit	•Kit reconditionnement	1,2	1"
	1	471 6657-21	•Repair kit	•Kit reconditionnement	1,2	1 1/4"
	1	471 6695-95	•Repair kit	•Kit reconditionnement	1,2	2"
4		•Plunger	•Bobine mobile			
5		•O-ring	•Joint torique			
6		•Spring	•Ressort			
7		•Diaphragm	•Diaphragme			
8		•O-ring	•Joint torique			

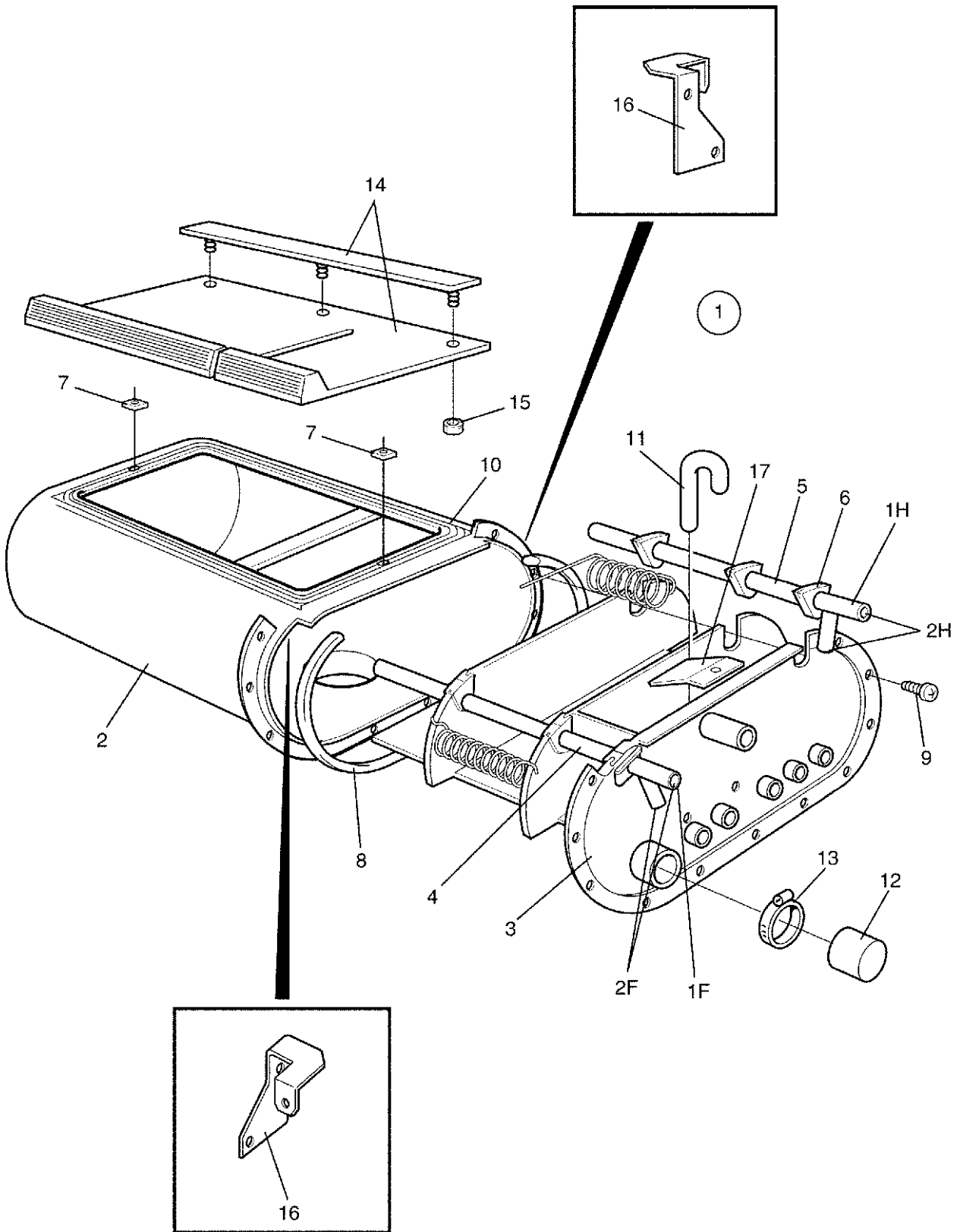

EXSM 230C,EXSM 230S

Detergent container

Compartiment à savon

Illustration Issue Month Year
Schéma Issue Month Year
100634 8 4 1996

Item Article	Qua. Qua.	Art.No Réf. article	Description	Description	Info Info	Notes Remarques
1						MED SKRUV I TOPPLOCKET WITH SCREW IN TOP PANEL
	1	472 6001-51	Detergent container	Compartiment à savon	1,2	1F-1H
	1	472 6001-52	Detergent container	Compartiment à savon	1,2	1F-2H
	1	472 6001-53	Detergent container	Compartiment à savon	1,2	2F-1H
2	1	472 6002-05	•Shell	•Pression coque	1	
3	1	472 6003-01	•Box	•Boîtier	1	
4	1	472 6005-10	•Spray head	•Vaporisateur	1	1F 1F
	1	472 6005-11	•Spray head	•Vaporisateur	1	2F 2F
5	1	472 6005-01	•Spray head	•Vaporisateur	1	1H 1H
	1	472 6005-02	•Spray head	•Vaporisateur	1	2H 2H
6	6	472 6004-01	Grommet	Oeillet	3	
7	2	471 8401-01	•Nut	•Écrou	3	M4
8	1	471 8163-01	•Gasket	•Joint	1	
9	11	471 8346-01	•Screw	•Vis	3	
10	1	438 0460-02	•Gasket	•Joint	1,2	
11	1	472 6006-01	•Siphon	•Siphon	1,2	
12	1	471 8644-03	Hood	Capot	3	
13	1	736 2828-51	Hose clamp	Attache flexible	3	
14	1	472 9902-59	Cover	Couvercle	1,2	
15	3	731 2314-42	•Nut	•Écrou	3	M4
16	2	438 4139-01	Bracket	Support de montage	3	W/FL 184-244
17	1	472 6756-01	Plate	Plaque	3	

Numerical index/Numerical index

Art.No/Réf. article	Page/Page	Art.No/Réf. article	Page/Page	Art.No/Réf. article	Page/Page	Art.No/Réf. article	Page/Page
432 0142-01	25	432 0926-01	39	471 2425-28	29	471 7803-21	37
432 0149-01	21	432 0927-01	19	471 2431-28	13	471 7814-02	13
432 0150-01	21	432 0928-01	21	471 2431-29	13	471 7851-03	29
432 0538-01	21	432 0929-01	7	471 2432-25	29	471 7859-11	33
432 0549-01	33	432 0933-01	9	471 2433-14	29	471 7859-11	35
432 0549-01	35	432 0936-01	17	471 2439-04	11	471 7859-16	33
432 0549-06	27	432 0940-02	7	471 2439-73	11	471 7859-16	35
432 0549-07	27	432 1125-01	33	471 2440-10	11	471 7864-01	7
432 0549-25	7	432 1127-01	9	471 2440-12	11	471 7864-01	9
432 0549-47	17	432 1129-01	31	471 2440-35	9	471 7958-01	23
432 0549-48	17	432 3087-11	23	471 2440-89	11	471 7958-01	25
432 0549-61	41	432 3901-01	17	471 2441-06	9	471 7958-02	25
432 0549-63	41	432 3905-01	17	471 2441-44	11	471 7961-02	13
432 0549-65	7	438 0033-01	13	471 2449-72	29	471 7977-01	31
432 0549-79	31	438 0084-03	29	471 2574-02	11	471 8126-18	41
432 0549-99	31	438 0127-01	29	471 2904-01	29	471 8149-11	9
432 0549-99	33	438 0145-08	29	471 2937-01	31	471 8158-02	9
432 0550-04	9	438 0151-01	9	471 2937-01	41	471 8159-06	31
432 0550-10	25	438 0167-01	41	471 4403-02	29	471 8163-01	47
432 0550-11	21	438 0168-02	41	471 4417-01	11	471 8175-01	29
432 0550-12	25	438 0299-01	25	471 4427-01	29	471 8180-12	7
432 0550-13	25	438 0330-01	41	471 4437-01	29	471 8192-01	7
432 0550-15	23	438 0341-02	41	471 4447-02	11	471 8210-01	45
432 0550-16	23	438 0422-01	13	471 4516-03	29	471 8210-02	45
432 0550-20	23	438 0456-01	11	471 4651-24	29	471 8210-03	45
432 0550-22	39	438 0457-01	11	471 4705-02	19	471 8210-11	45
432 0550-35	35	438 0458-01	11	471 4792-01	31	471 8210-12	45
432 0550-36	35	438 0459-01	11	471 4792-01	43	471 8210-21	45
432 0550-40	15	438 0460-02	47	471 4835-01*	29	471 8210-22	45
432 0550-43	27	438 4088-01	19	471 5103-05	29	471 8210-31	45
432 0550-46	15	438 4100-01	11	471 6657-15	45	471 8210-32	45
432 0550-66	21	438 4101-01	11	471 6657-16	45	471 8210-51	45
432 0550-87	21	438 4117-01	13	471 6657-17	45	471 8210-52	45
432 0550-95	35	438 4126-02	13	471 6657-18	45	471 8210-63	31
432 0550-96	35	438 4127-02	13	471 6657-19	45	471 8234-92	43
432 0550-98	35	438 4128-01	13	471 6657-20	45	471 8234-94	43
432 0555-02	39	438 4130-01	13	471 6657-21	45	471 8234-95	43
432 0629-01	31	438 4132-02	13	471 6695-95	45	471 8234-96	43
432 0630-01	9	438 4139-01	47	471 6860-15	43	471 8234-98	43
432 0631-01	33	438 4149-01	39	471 6860-16	43	471 8236-52	43
432 0631-01	35	438 4158-01	7	471 6860-17	43	471 8236-56	43
432 0632-01	25	438 4158-02	7	471 6860-18	43	471 8236-57	43
432 0632-02	25	438 4171-01	9	471 6860-19	43	471 8236-60	43
432 0633-01	25	438 4171-09	9	471 6860-20	43	471 8236-62	43
432 0635-01	23	438 4172-01	9	471 7182-23	33	471 8236-64	43
432 0636-01	23	438 4176-02	11	471 7182-23	35	471 8236-65	31
432 0639-01	35	438 4182-01	7	471 7668-01	13	471 8236-65	43
432 0641-02	15	438 4184-01	7	471 7668-02	13	471 8236-66	43
432 0647-01	7	438 4193-01	11	471 7668-03	13	471 8236-68	43
432 0648-01	7	438 4219-01	13	471 7668-04	13	471 8279-03	41
432 0808-01	25	438 4326-11	13	471 7668-05	13	471 8279-08	41
432 0808-02	25	438 4326-12	13	471 7668-06	13	471 8308-07	41
432 0808-03	25	438 4420-20	11	471 7668-07	13	471 8311-00	11
432 0808-04	25	438 4424-01	9	471 7668-08	13	471 8340-23	41
432 0915-01	9	438 4426-02	11	471 7668-09	13	471 8340-26	19
432 0916-01	9	438 5154-01	19	471 7668-10	13	471 8340-26	21
432 0916-02	9	438 5154-01	21	471 7668-11	13	471 8341-17	39
432 0917-01	9	438 5326-01	9	471 7668-12	13	471 8341-24	39
432 0917-02	9	438 5335-01	9	471 7668-13	13	471 8341-46	7
432 0918-01	9	438 5341-01	19	471 7674-01	13	471 8341-50	13
432 0919-01	9	438 9550-51	7	471 7694-42	19	471 8341-85	13
432 0919-03	9	438 9555-01	23	471 7694-46	21	471 8342-11	37
432 0920-01	9	438 9555-01	25	471 7711-05	15	471 8342-11	39
432 0921-01	7	438 9799-02	17	471 7711-05	17	471 8342-13	23
432 0923-01	29	438 9799-03	17	471 7716-13	19	471 8342-44	37
432 0925-01	39	471 2416-83	11	471 7716-14	21	471 8346-01	47

Numerical index/Numerical index

Art.No/Réf. article	Page/Page	Art.No/Réf. article	Page/Page	Art.No/Réf. article	Page/Page	Art.No/Réf. article	Page/Page
471 8356-06	15	472 6001-52	47				
471 8356-06	17	472 6001-53	47				
471 8401-01	47	472 6002-05	47				
471 8402-01	11	472 6003-01	47				
471 8410-01	19	472 6004-01	47				
471 8502-10	15	472 6005-01	47				
471 8502-10	17	472 6005-02	47				
471 8502-14	11	472 6005-10	47				
471 8512-01	11	472 6005-11	47				
471 8551-02	11	472 6006-01	47				
471 8622-01	41	472 6756-01	47				
471 8623-01	31	472 6761-01	31				
471 8641-01	9	472 8754-13	29				
471 8644-03	47	472 9187-01	37				
471 8670-03	41	472 9901-33	37				
471 8693-12	31	472 9902-11	11				
471 8693-21	31	472 9902-59	47				
471 8750-11	33	472 9903-43	13				
471 8750-11	35	472 9913-22	7				
471 8750-22	27	725 2366-61	11				
471 8756-51	33	725 2366-61	41				
471 8756-51	35	725 2453-51	15				
471 8759-01	33	725 2536-51	7				
471 8759-01	35	725 2630-51	7				
471 8781-01	33	725 2634-71	11				
471 8781-01	35	731 2314-42	47				
471 8781-02	33	731 2318-01	41				
471 8781-02	35	732 2112-01	39				
471 8781-03	33	732 2118-01	11				
471 8781-03	35	732 2122-01	7				
471 8781-11	33	732 2122-01	15				
471 8781-11	35	732 2122-01	17				
471 8792-01	25	732 2124-01	7				
471 8793-01	21	732 3116-14	13				
471 8859-06	23	734 1153-09	13				
471 8859-06	25	734 1164-01	15				
471 8988-04*	19	734 1178-01	7				
471 8993-01	25	734 1178-01	15				
471 8995-01	25	734 1186-01	7				
471 8995-02	25	734 1186-01	11				
471 8995-03	25	735 3126-01	13				
471 8997-02	21	736 2816-51	29				
471 9004-75	19	736 2816-51	31				
471 9004-75	21	736 2825-51	11				
471 9222-59	11	736 2825-51	29				
471 9529-10	23	736 2825-51	31				
471 9529-10	25	736 2828-51	47				
471 9550-14	9	736 2831-51	29				
471 9550-19	9	736 2837-51	29				
471 9558-11	23	736 2840-51	29				
471 9578-50	15	736 2846-51	29				
471 9628-20	21	736 2849-51	29				
471 9628-22	21	744 3115-06	41				
471 9628-32	21	762 1191-10	9				
471 9628-33	21	762 1209-10	9				
471 9628-90	21	762 3211-01	23				
471 9628-99	21	762 3211-01	25				
471 9654-03	39	762 3231-01	23				
471 9741-03	15	762 3231-01	25				
471 9741-04	17	762 3231-01	33				
471 9771-01	27	762 3251-01	25				
471 9773-01	27	762 9105-05	31				
471 9774-02	27	877 5211-08	31				
472 5763-09	19						
472 5775-01	21						
472 6001-51	47						

WASCOMAT

461 Doughty Blvd., Inwood, L.I., N.Y. 11096-0338

Telephone: 516-371-4400

Parts and Service FAX: 516-371-4029

Sales and Administration FAX: 516-371-4204