

WASCOMAT

Spare Parts Catalogue
Catalogue de pièces de rechange

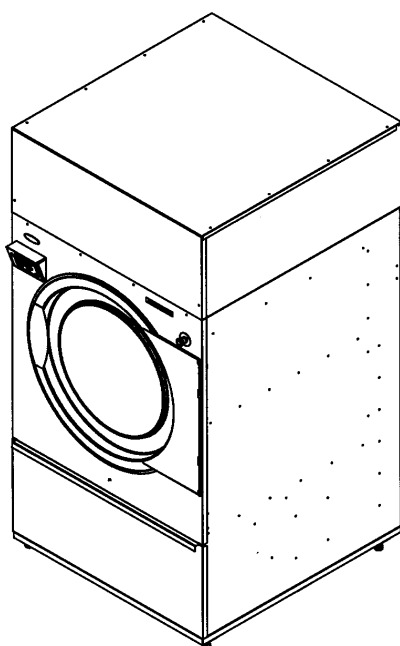

TD100, T3900

List of issues

T3900,TD100

Illustration	Page	Table of contents
200033	7	Cabinet complete
200034	19	Door complete
200035	27	Drum, compl.
200036	33	Motor alternative
200037	41	Filter/ Fan housing
200038	43	Heater unit, el
200039	45	Heater unit, gas
200040	49	Heating unit, steam
200041	53	Connection unit, el
200042	61	Connection unit, gas, steam
200097	13	Controlbox, complete
200098	37	Frequency converter, complete
200123	31	Drum with moisture sensor
200126	23	Filter hatch, joined
200132	11	Cabinet complete - Sliding Door
200133	21	Door complete - Sliding Door
200134	25	Filter hatch, joined - Sliding Door
200135	17	Front panel - tilt + frequency, complete
200136	15	Front panel - Sliding Door/ frequency, complete
200137	35	Door switch - Sliding Door
200138	51	Box - heating unit Sliding Door
200139	29	Drum, compl.
200141	39	Tilt
200144	47	Gas components - Australia
200165	57	Connection unit - Sliding Door + Tilt, el
200166	63	Connection unit - Sliding Door + Tilt, gas + steam

T3900,TD100

Table of contents	Table des matières	Page/Page
Cabinet complete	Armoire complète	7
Cabinet complete - Sliding Door	Armoire complète - Sliding Door	11
Controlbox, complete	Boîtier de contrôle, complet	13
Front panel - Sliding Door/ frequency, complete	Panneau de façade - Sliding Door/ fréquence, complet	15
Front panel - tilt + frequency, complete	Panneau de façade - inclinaison + fréquence, complet	17
Door complete	Plaque complète	19
Door complete - Sliding Door	Plaque complète - Sliding Door	21
Filter hatch, joined	Plaque filtre, collecté	23
Filter hatch, joined - Sliding Door	Plaque filtre, collecté - Sliding Door	25
Drum, compl.	Tambour, complet	27
Drum, compl.	Tambour, complet	29
Drum with moisture sensor	Tambour avec capteur humidité	31
Motor alternative	Alternative moteur	33
Door switch - Sliding Door	Interrupteur de porte - Sliding Door	35
Frequency converter, complete	Convertisseur de fréquence, complet	37
Tilt	Inclinaison	39
Filter/ Fan housing	Filtre/ Boîtier de ventilateur	41
Heater unit, el	Élément chauffant, el	43
Heater unit, gas	Élément chauffant, gaz	45
Gas components - Australia	Composants gaz - Australie	47
Heating unit, steam	Unité chauffage, vapeur	49
Box - heating unit Sliding Door	Caise - unite chauffage Sliding Door	51
Connection unit, el	Connexion, électrique	53
Connection unit - Sliding Door + Tilt, el	Connexion - Sliding Door + Inclinaison, électrique	57
Connection unit, gas, steam	Connexion, gaz, vapeur	61
Connection unit - Sliding Door + Tilt, gas + steam	Connexion - Sliding Door + Inclinaison, gaz + vapeur	63

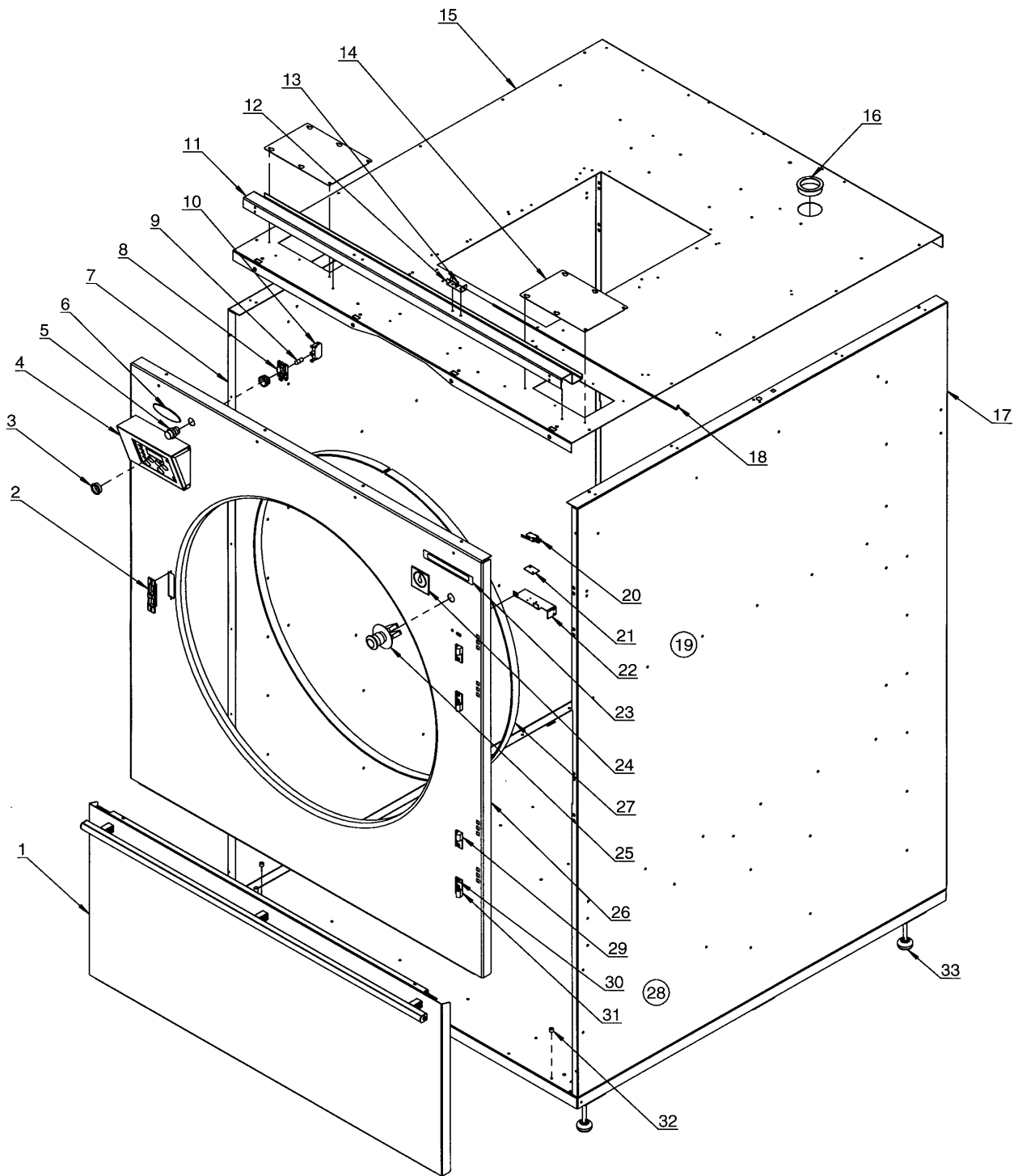

Issue	Month	Year
04	04	04

T3900,TD100

Cabinet complete

Armoire complète

Illustration Issue Month Year
Schéma Issue Month Year
200033/3 4 4 2004

Item Article	Qua Qua	Art.No Réf. article	Description	Description	Info Info	Notes Remarques
1	1	487 1714-99	Filter hatch	Volet du filtre		Complete See illustr. 200126
2	1	487 1816-56	Locking unit	Unité verrouillage	3	
	1	762 1191-10	Cable gland	Passe-fil	3	Ø22
4	1	487 1714-78	Controlbox	Boîtier de contrôle		Complete See illustr. 200097
5	1	487 0289-75	Lamp	Lampe	3	Yellow
6	1	432 2620-06	Sign	Signe	3	Electrolux Wascator
	1	432 2620-07	Sign	Signe	3	Electrolux Nyborg
	1	432 2620-08	Sign	Signe	3	Electrolux Dubix
	1	432 2620-09	Sign	Signe	3	Electrolux
7	1	487 2406-05	Side plate	Plaque de côté	3	Left White
	1	487 2410-40	Side plate	Plaque de côté	3	Left Grey
	1	487 2410-55	Side plate	Plaque de côté	3	Left Stainless
8	1	471 9628-75	Bracket	Support	3	
9	1	487 0289-69	Glowing lamp	Lampa à incandescence	3	
10	1	487 0289-76	Lamp socket	Douille de lampe	3	
11	1	487 2400-61	Support	Support	3	
12	1	487 2406-01	Fitting	Garniture	3	
13	1	487 1626-04	Disc	Disque	3	Grifax
14	2	487 2256-07	Cover plate	Plaque recouvrement	3	
15	1	487 2405-65	Top panel	Panneau supérieur	3	
16	1	487 1723-95	Cable gland	Passe-fil	3	Ø50
17	1	487 2409-05	Side plate	Plaque de côté	3	Right White
	1	487 2409-40	Side plate	Plaque de côté	3	Right Grey
	1	487 2409-55	Side plate	Plaque de côté	3	Right Stainless
18	1	487 2406-02	Bracket	Support	3	
19	1	487 2359-73	Door switch	Interrupteur de porte	3	Complete
20	1	487 1898-10	•Microswitch	•Microrupteur	1,2	
21	1	471 2068-48	•Insulation	•Isolation	3	
22	1	487 2359-70	•Bracket	•Support	3	
23	1	487 1969-83	Type plate	Numéro série plaque	3	T3900
24	1	487 1714-79	Emergency stop	Arrêt d'urgence	3	Complete
25	1	471 4672-16	Sign	Signe	3	Aqua - Clean
26	1	487 1714-80	Front complete	Devant complete	3	Right-hinged White
	1	487 1714-81	Front complete	Devant complete	3	Right-hinged Red
	1	487 1714-82	Front complete	Devant complete	3	Right-hinged Green
	1	487 1714-83	Front complete	Devant complete	3	Right-hinged Stainless
	1	487 1714-84	Front complete	Devant complete	3	Right-hinged Beige
	1	487 1714-85	Front complete	Devant complete	3	Right-hinged Ivory
	1	487 1714-86	Front complete	Devant complete	3	Left-hinged White
	1	487 1714-87	Front complete	Devant complete	3	Left-hinged Red
	1	487 1714-88	Front complete	Devant complete	3	Left-hinged Green
	1	487 1714-89	Front complete	Devant complete	3	Left-hinged Stainless
	1	487 1714-90	Front complete	Devant complete	3	Left-hinged Beige
	1	487 1714-91	Front complete	Devant complete	3	Left-hinged Ivory
	1	487 1935-19	Front complete	Devant complete	3	Indicator Right-hinged White
	1	487 1935-20	Front complete	Devant complete	3	Indicator Right-hinged Red
	1	487 1935-21	Front complete	Devant complete	3	Indicator Right-hinged Green
	1	487 1935-22	Front complete	Devant complete	3	Indicator Right-hinged Stainless
	1	487 1935-23	Front complete	Devant complete	3	Indicator Right-hinged Beige
	1	487 1935-24	Front complete	Devant complete	3	Indicator Right-hinged Ivory
	1	487 1935-25	Front complete	Devant complete	3	Indicator Left-hinged White
	1	487 1935-26	Front complete	Devant complete	3	Indicator Left-hinged
	1	487 1935-27	Front complete	Devant complete	3	Indicator Left-hinged Green
	1	487 1935-28	Front complete	Devant complete	3	Indicator Left-hinged Stainless
	1	487 1935-29	Front complete	Devant complete	3	Indicator Left-hinged Beige
	1	487 1935-30	Front complete	Devant complete	3	Indicator Left-hinged Ivory
27	1	487 2400-18	•Felt sealing	•Joint feutre	1	
* 28	2	487 3390-02	Hinge	Charnière	3	Complete
* 29	2	487 2336-61	•Hinge	•Charnière	3	Upper

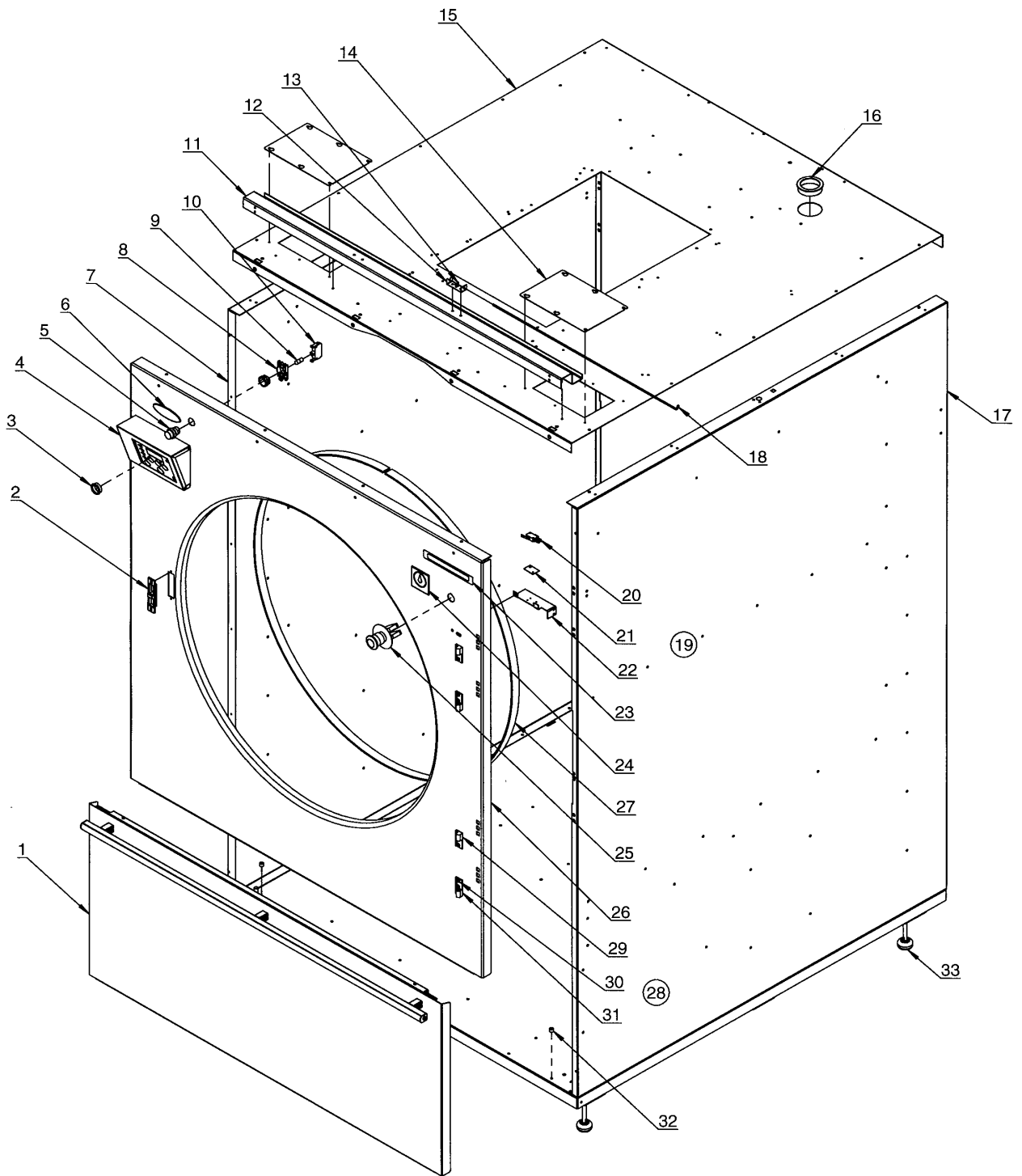

Issue	Month	Year
04	04	04

T3900,TD100

Cabinet complete

Armoire complète

Illustration	Issue	Month	Year
Schéma	Issue	Month	Year
200033/3	4	4	2004

Item Article	Qua Qua	Art.No Réf. article	Description	Description	Info Info	Notes Remarques
* 30	4	487 1760-31	•Screw	•Vis	3	M5X12
* 31	2	487 2336-60	•Hinge	•Charnière	3	Lower
* 32	2	472 7414-01	Spacer sleeve	Manchon entretoise	3	Ø10/Ø6
* 33	4	487 1714-92	Foot	Pied	3	Complete

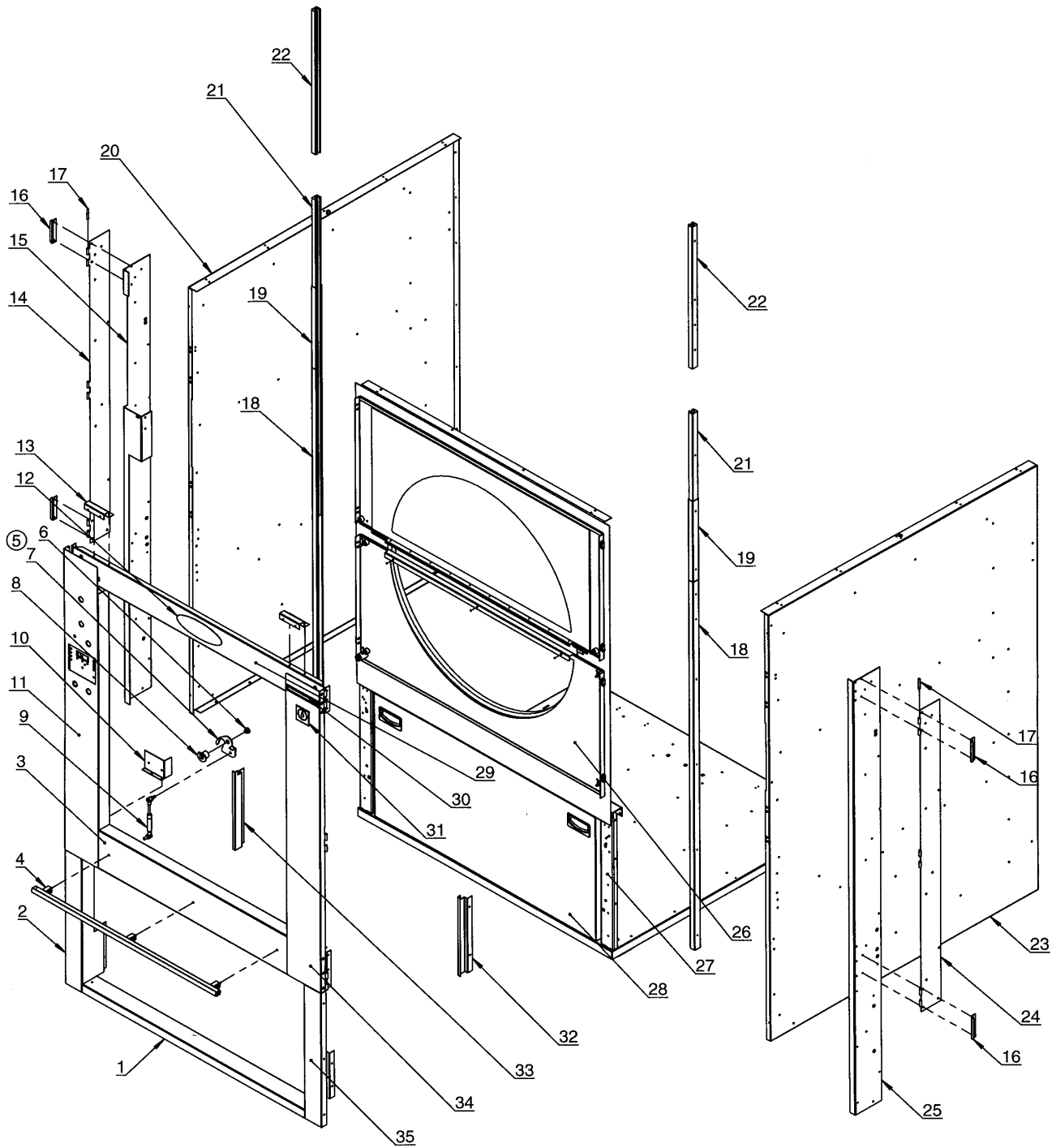

Issue	Month	Year
02	04	04

T3900,TD100

Cabinet complete - Sliding Door

Armoire complète - Sliding Door

Illustration Issue Month Year
Schéma Issue Month Year
200132/1 2 4 2004

Item Article	Qua Qua	Art.No Réf. article	Description	Description	Info Info	Notes Remarques
1	1	487 2426-18	Cross beam	Poutre transversale	3	Bottom
2	1	487 2426-09	Panel	Panneau	3	Left Bottom
3	1	487 2426-84	Beam	Poutre	3	Complete Bottom
4	1	487 2426-82	•Handle	•Manivelle	3	Complete
5	1	487 2436-10	•Lock washer	•Rondelle d'arrêt	3	Complete
6	1	487 2426-91	••Bushing	••Douille	3	
7	1	487 2426-24	••Locking plate	••Gâche de serrure	3	
8	1	487 2426-48	•Lock washer	•Rondelle d'arrêt	3	
9	1	487 2426-99	•Gas cylinder	•Vérin à gaz	3	
* 10	1	487 1935-73	Screen	Écran	3	Complete
11	1	487 2447-70	Front panel	Panneau de façade	3	See illustr. 200136, 200135
12	1	487 2228-35	Sign	Signe	3	Electrolux
13	2	487 2426-54	Fitting	Garniture	3	
14	1	487 2426-16	Hinge plate	Paumelle	3	Left Left-hinged
15	1	487 2426-51	Side profile	Profilé latéral	3	Left Left-hinged
	1	487 2426-56	Side profile	Profilé latéral	3	Right Right-hinged
16	4	487 2427-57	Stop plate	Gâche	3	
17	6	487 2426-98	Screw	Vis	3	M6X100 Stainless
18	2	487 2426-07	Rail	Rail	3	Galvanised Lower
19	2	487 2426-06	Rail	Rail	3	Galvanised Upper
20	1	487 2441-05	Side plate	Plaque de côté	3	White Left
	1	487 2441-40	Side plate	Plaque de côté	3	Grey Left
21	2	487 2426-63	Rail	Rail	3	Nylon Lower
22	2	487 2426-62	Rail	Rail	3	Nylon Upper
23	1	487 2440-05	Side plate	Plaque de côté	3	White Right
	1	487 2440-40	Side plate	Plaque de côté	3	Grey Right
24	1	487 2426-17	Hinge plate	Paumelle	3	Right
25	1	487 2426-52	Side profile	Profilé latéral	3	Right Left-hinged
	1	487 2426-53	Side profile	Profilé latéral	3	Left Right-hinged
26	1	487 2439-99	Door	Plaque	3	Complete See illustr. 200133
27	2	487 2400-26	Post	Montant	3	See illustr. 200037
28	1	487 2427-99	Filter hatch	Volet du filtre	3	See illustr. 200134
* 29	1	487 2426-88	Beam	Poutre	3	Complete
* 30	1	487 2228-26	Type plate	Numéro série plaque	3	T3900
	1	487 2228-23	Type plate	Numéro série plaque	3	Aqua - Clean
* 31	1	471 4672-16	Sign	Signe	3	Aqua - Clean
* 32	1	487 2426-55	Panel	Panneau	3	Right Bottom
* 33	1	487 2426-02	Panel	Panneau	3	Left Bottom
* 34	1	487 2447-80	Front panel	Panneau de façade	3	Right Left-hinged
*	1	487 2447-81	Front panel	Panneau de façade	3	Left Right-hinged
* 35	1	487 2426-08	Panel	Panneau	3	Right Bottom

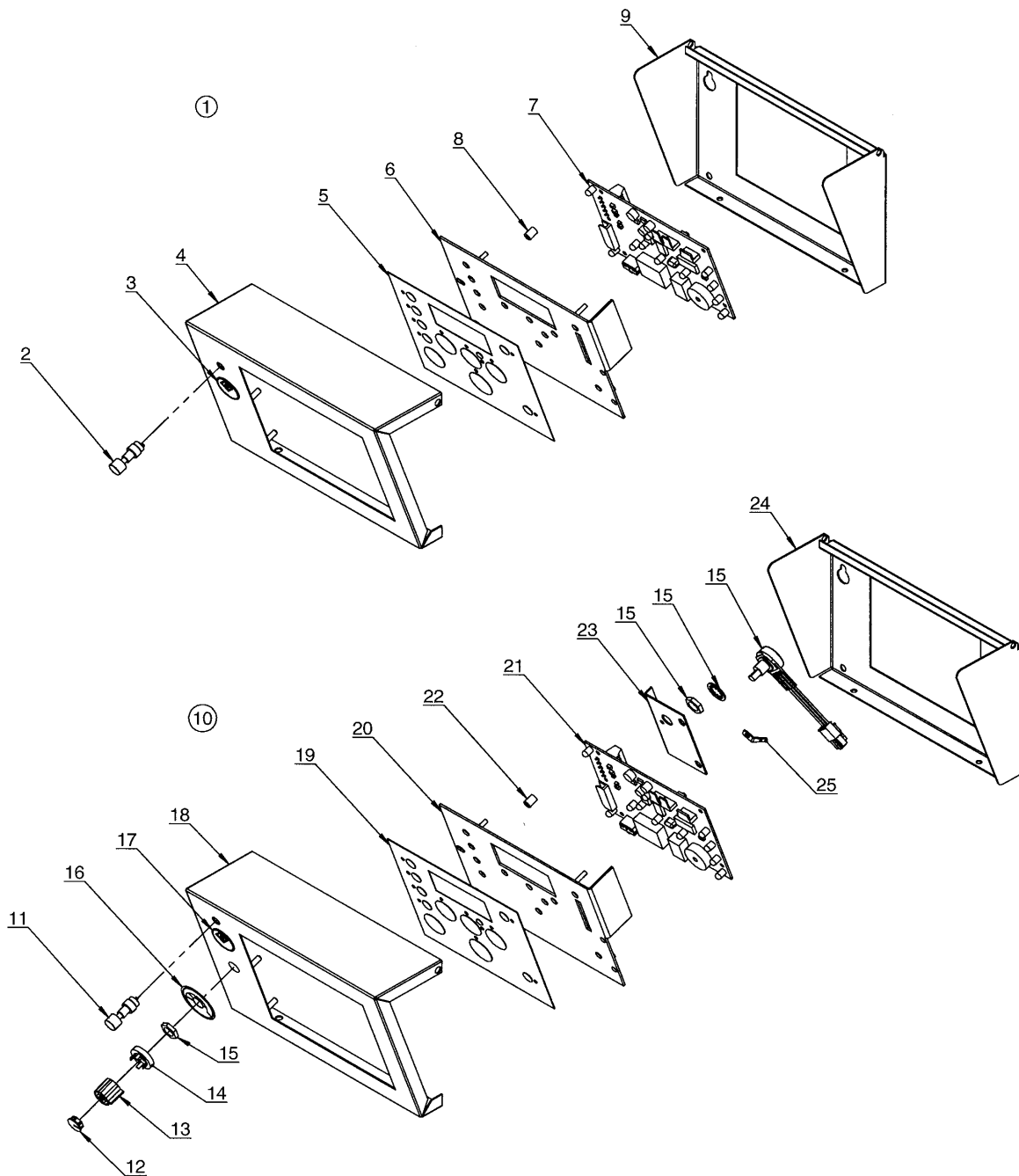

Issue	Month	Year
01	12	03

T3900,TD100

Controlbox, complete

Boîtier de contrôle, complet

Illustration Issue Month Year
Schéma Issue Month Year
200097/1 2 1 2004

Item Article	Qua Qua	Art.No Réf. article	Description	Description	Info Info	Notes Remarques
1	1	487 1714-78	Controlbox	Boîtier de contrôle	3	Complete Electric + gas + steam
2	1	487 1934-20	•Cable set	•Ensemble de câbles	3	Gas
3	1	487 1969-88	•Sign	•Signe	3	Reset Gas
4	1	487 2411-80	•Outer panel	•Panneau extérieur	3	Gas
5	1	487 1924-03	•Operation sign	•Etiquette	3	OPL
6	1	487 2405-82	•Assembly plate	•Plaque de montage	3	
7	1	487 1714-70	•Printed circuit board	•Carte de circuit imprimé	1,2	Complete
8	4	487 1535-21	••Spacer element	••Pièce écartement	3	
9	1	487 2405-81	•Bracket	•Console	3	
10	1	487 1935-15	Controlbox	Boîtier de contrôle	3	Complete Frequency
11	1	487 1934-20	•Cable set	•Ensemble de câbles	3	Gas Frequency
12	1	487 0289-66	•Cover button	•Cache-bouton	3	Frequency
13	1	487 0289-65	•Turning device	•Dispositif	3	Frequency
14	1	487 0289-64	•Socket	•Socle	3	Frequency
15	1	487 0199-51	•Potentiometer	•Potentiomètre	3	Frequency
16	1	487 2226-87	•Sign	•Signe	3	Frequency
17	1	487 1969-88	•Sign	•Signe	3	Reset Gas Frequency
18	1	487 2411-81	•Outer panel	•Panneau extérieur	3	Frequency
19	1	487 1924-03	•Operation sign	•Etiquette	3	OPL Frequency
20	1	487 2405-82	•Assembly plate	•Plaque de montage	3	Frequency
21	1	487 1714-70	•Printed circuit board	•Carte de circuit imprimé	1,2	Complete Frequency
22	4	487 1535-21	••Spacer element	••Pièce écartement	3	Frequency
23	1	487 2406-09	•Assembly plate	•Plaque de montage	3	Frequency
24	1	487 2405-81	•Bracket	•Console	3	Frequency
25	1	487 7057-40	•Terminal	•Terminal	3	

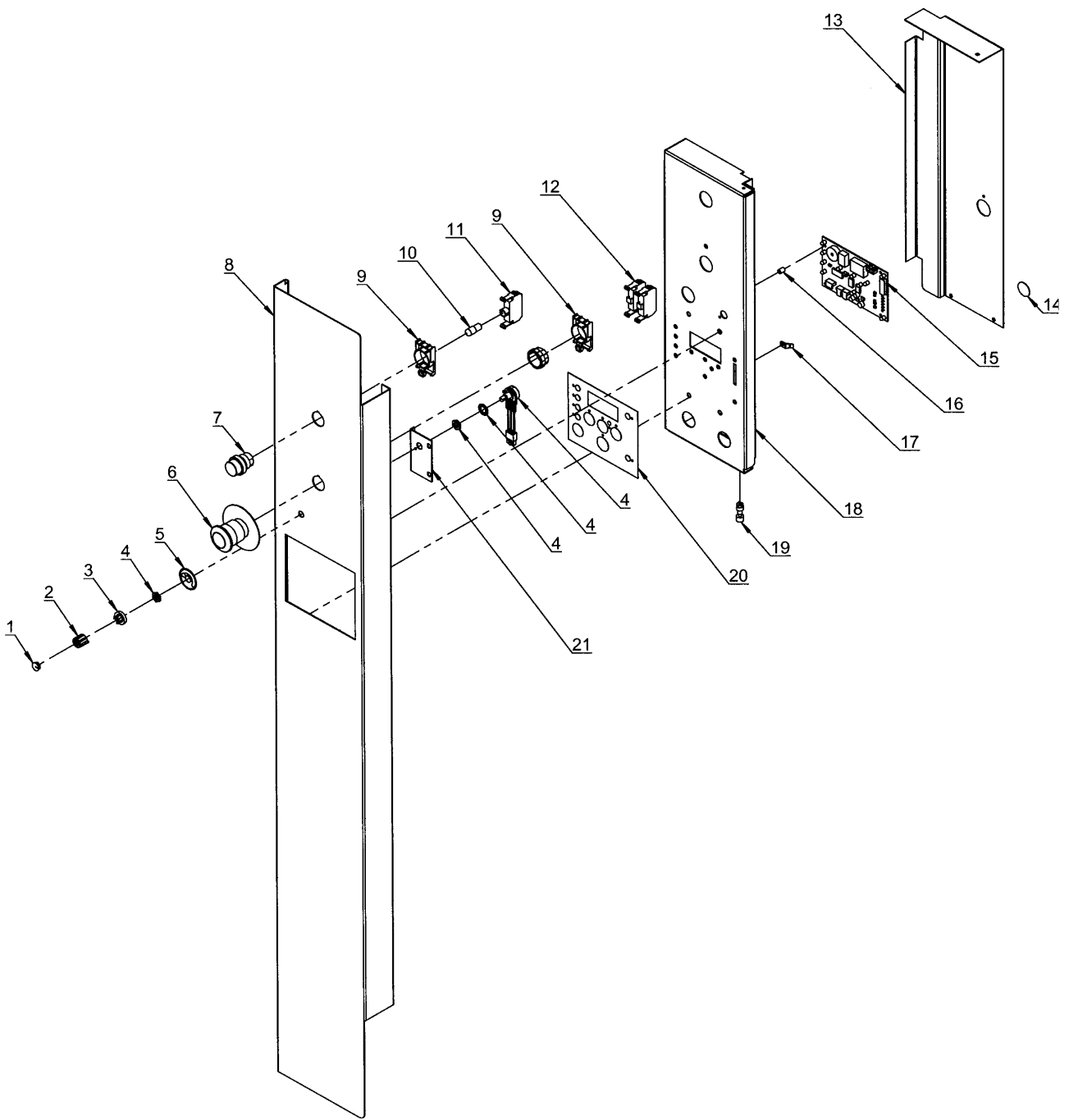

Issue	Month	Year
02	04	04

T3900,TD100

Front panel - Sliding Door/ frequency, complete

Panneau de façade - Sliding Door/ fréquence, complet

Illustration Issue Month Year
Schéma Issue Month Year
200136/1 2 4 2004

Item Article	Qua Qua	Art.No Réf. article	Description	Description	Info Info	Notes Remarques
1	1	487 0289-66	Cover button	Cache-bouton	3	
2	1	487 0289-65	Turning device	Dispositif	3	
3	1	487 0289-64	Socket	Socle	3	
4	1	487 0199-53	Potentiometer	Potentiomètre	3	Left-hinged
	1	487 0199-54	Potentiometer	Potentiomètre	3	Right-hinged
5	1	487 2226-87	Sign	Signe	3	Frequency
6	1	471 9628-32	Push-button	Bouton poussoir	3	Emergency stop
7	1	487 0289-75	Lamp	Lampe	3	Yellow
8	1	487 2426-70	Front panel	Panneau de façade	3	Left-hinged Frequency
	1	487 2426-71	Front panel	Panneau de façade	3	Right-hinged Frequency
	1	487 2426-74	Front panel	Panneau de façade	3	Left-hinged Standard
	1	487 2426-75	Front panel	Panneau de façade	3	Right-hinged Standard
9	1	471 9628-75	Bracket	Support	3	Emergency stop
10	1	487 0289-69	Glowing lamp	Lampa à incandescence	3	
11	1	487 0289-76	Lamp socket	Douille de lampe	3	
12	2	471 9628-70	Socket	Bloc de connexion	3	Emergency stop
* 13	1	487 2427-24	Cover	Couvercle	3	EI Right-hinged
*	1	487 2427-44	Cover	Couvercle	3	EI Left-hinged
* 14	1	487 1969-88	Sign	Signe	3	Reset Gas
* 15	1	487 1714-70	Printed circuit board	Carte de circuit imprimé	1,2	Complete
* 16	4	487 1535-21	*Spacer element	*Pièce écartement	1,2	
* 17	1	487 7057-40	Terminal	Terminal	3	
* 18	1	487 2426-04	Plate	Plaque	3	
* 19	1	487 1934-20	Cable set	Ensemble de câbles	3	Gas Reset
20	1	487 1924-03	Operation sign	Etiquette	3	OPL
21	1	487 2427-04	Plate	Plaque	3	Potentiometer

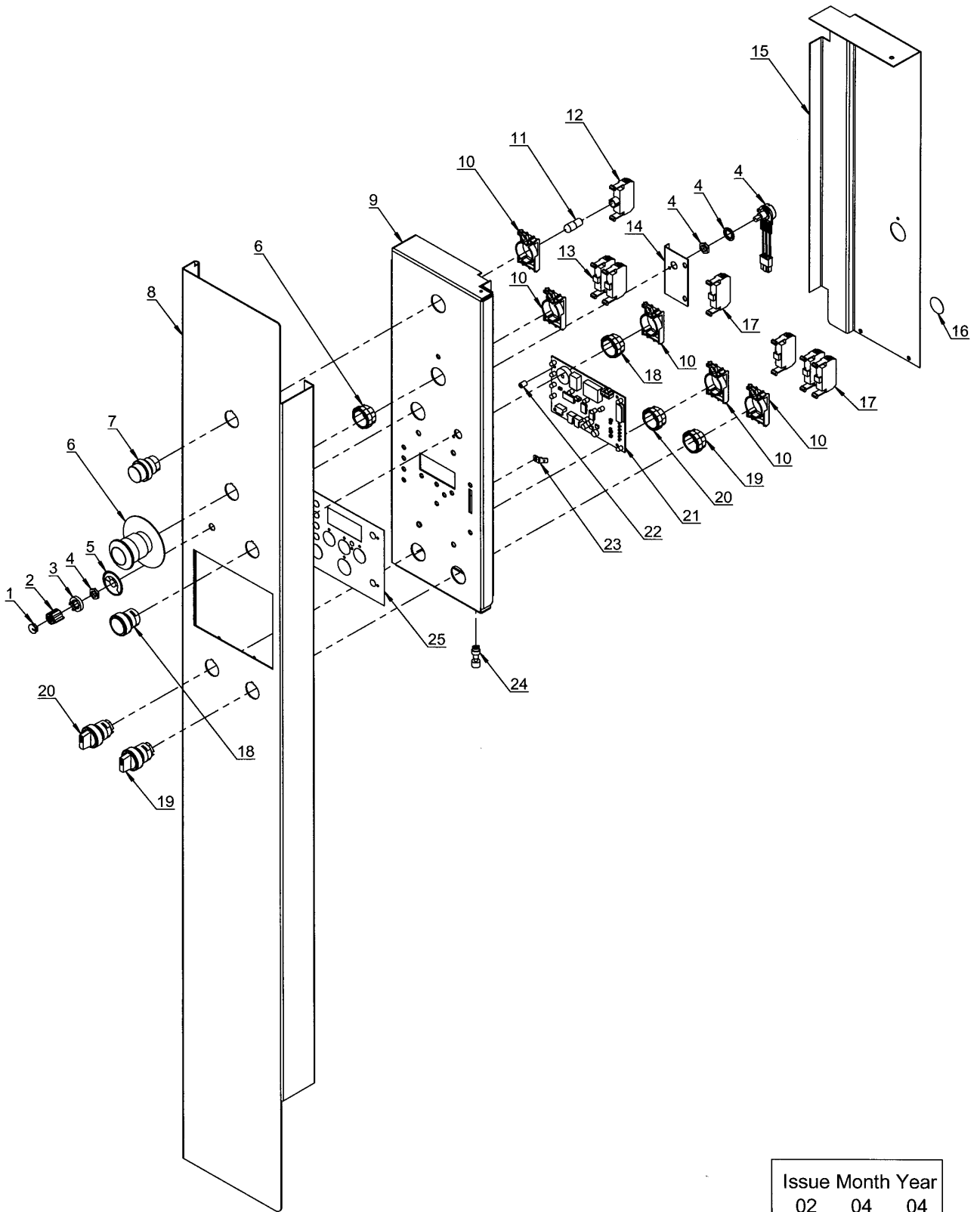

Issue Month Year
02 04 04

T3900,TD100

Front panel - tilt + frequency, complete

Panneau de façade - inclinaison + fréquence, complet

Illustration Issue Month Year
Schéma Issue Month Year
200135/2 2 4 2004

Item Article	Qua Qua	Art.No Réf. article	Description	Description	Info Info	Notes Remarques
1	1	487 0289-66	Cover button	Cache-bouton	3	
2	1	487 0289-65	Turning device	Dispositif	3	
3	1	487 0289-64	Socket	Socle	3	
4	1	487 0199-53	Potentiometer	Potentiomètre	3	
	1	487 0199-54	Potentiometer	Potentiomètre	3	
5	1	487 2226-87	Sign	Signe	3	Frequency
6	1	471 9628-32	Push-button	Bouton poussoir	3	Emergency stop
7	1	487 0289-75	Lamp	Lampe	3	Yellow
8	1	487 2426-68	Front panel	Panneau de façade	3	Left-hinged Tilt + frequency
	1	487 2426-69	Front panel	Panneau de façade	3	Right-hinged Tilt + frequency
	1	487 2426-72	Front panel	Panneau de façade	3	Left-hinged Tilt
	1	487 2426-73	Front panel	Panneau de façade	3	Right-hinged Tilt
* 9	1	487 2426-04	Plate	Plaque	3	Printed circuit board
* 10	5	471 9628-75	Bracket	Support	3	
* 11	1	487 0289-69	Glowing lamp	Lampa à incandescence	3	
* 12	1	487 0289-76	Lamp socket	Douille de lampe	3	
* 13	2	471 9628-70	Socket	Bloc de connexion	3	Red
* 14	1	487 2427-04	Plate	Plaque	3	Potentiometer
* 15	1	487 2427-24	Cover	Couvercle	3	EI Right-hinged
*	1	487 2427-44	Cover	Couvercle	3	EI Left-hinged
* 16	1	487 1969-88	Sign	Signe	3	Reset Gas
* 17	4	471 9628-71	Socket	Bloc de connexion	3	Green
* 18	1	487 0289-74	Push-button	Bouton poussoir	3	
* 19	1	487 0289-73	Turning device	Dispositif	3	
* 20	1	487 0289-72	Turning device	Dispositif	3	Tilt
* 21	1	487 1714-70	Printed circuit board	Carte de circuit imprimé	1,2	Complete
* 22	4	487 1535-21	•Spacer element	•Pièce écartement	1,2	
* 23	1	487 7057-40	Terminal	Terminal	3	
24	1	487 1934-20	Cable set	Ensemble de câbles	3	Gas Reset
25	1	487 1924-03	Operation sign	Etiquette	3	OPL

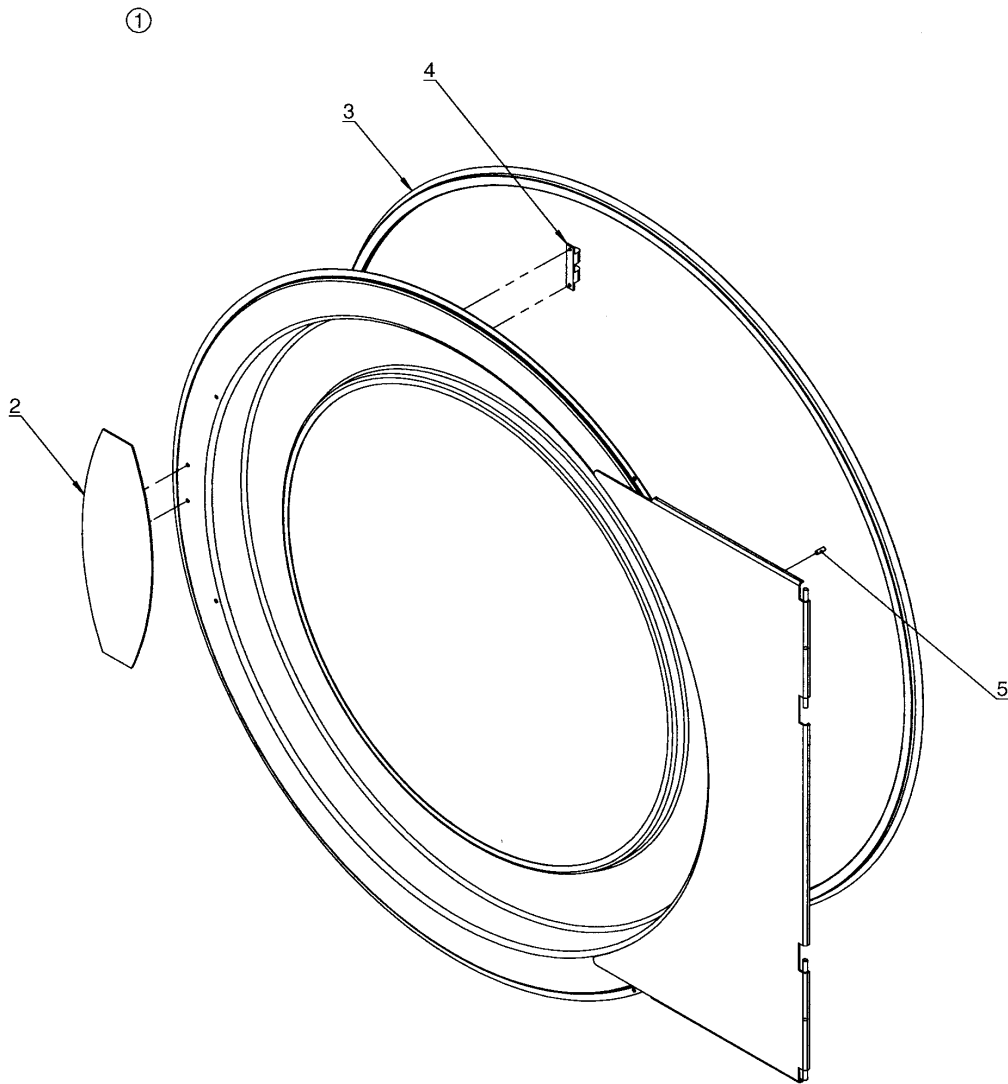

T3900,TD100

Door complete

Plaque complète

Illustration	Issue	Month	Year
Schéma	Issue	Month	Year
200034/1	1	3	2003

Item Article	Qua Qua	Art.No Réf. article	Description	Description	Info Info	Notes Remarques
1	1	487 2408-82	Door	Plaque	3	Complete
2	1	487 0187-28	Handle	Manivelle	3	
3	1	487 2400-24	Door gasket	Joint de la porte	1	
4	1	487 1818-25	Snap catch	Cliquet	3	
5	1	487 1756-35	Bushing	Douille	3	

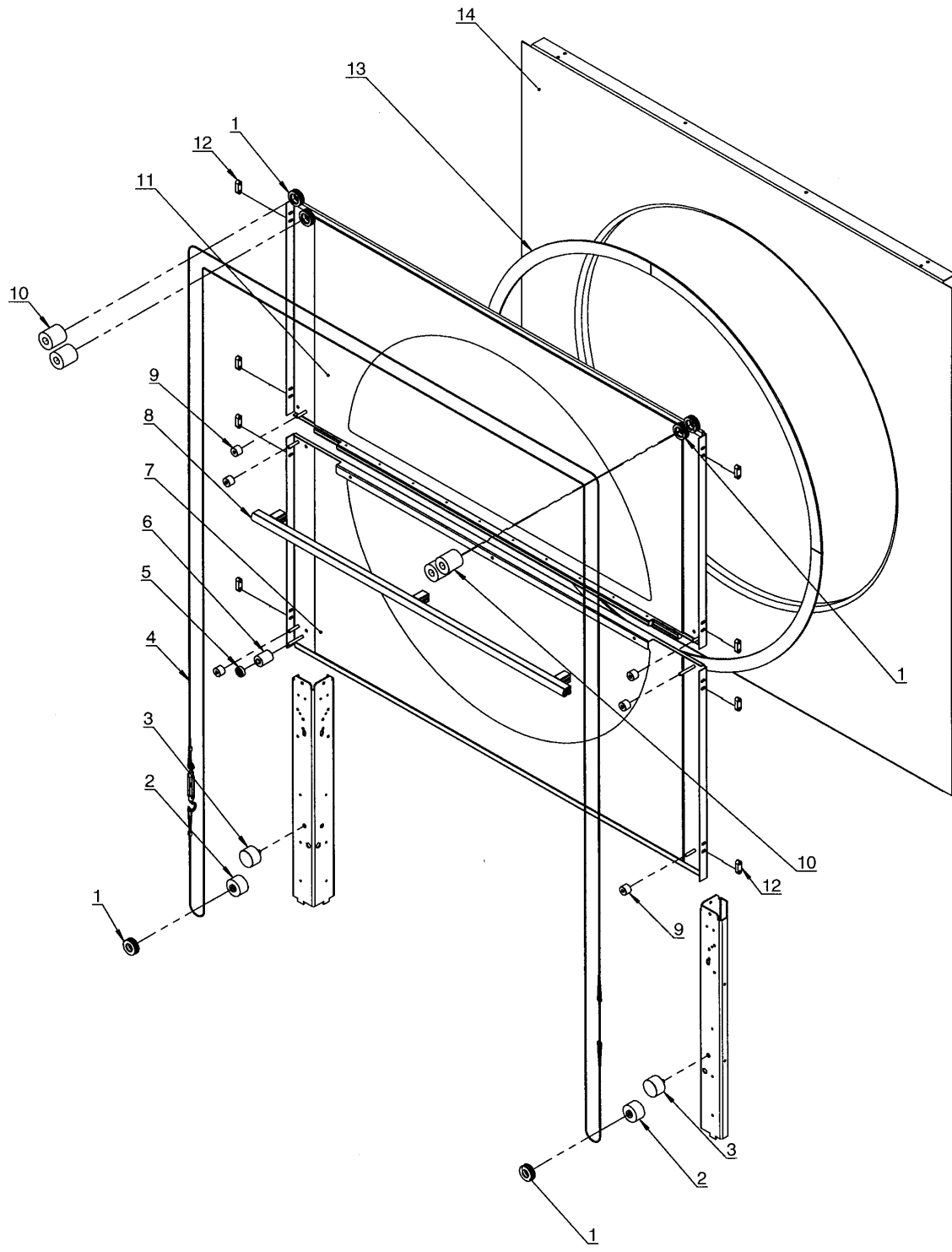

Issue	Month	Year
01	01	04

T3900,TD100

Door complete - Sliding Door

Plaque complète - Sliding Door

Illustration Issue Month Year
Schéma Issue Month Year
200133/1 1 1 2004

Item Article	Qua Qua	Art.No Réf. article	Description	Description	Info Info	Notes Remarques
1	6	487 2426-85	Wheel	Roue	3	Complete Steel wire
2	2	487 2426-22	Bushing	Douille	3	Bottom
3	2	487 2426-50	Rubber bushing	Douille caoutchouc	3	
4	1	487 2436-11	Steel wire	Câble métallique	3	Complete
5	1	487 2426-31	Ball bearing	Roulement à billes	3	
6	1	487 2426-39	Bearing cage	Cage de palier	3	
7	1	487 2436-07	Door complete	Plaque complète	3	Lower Right-hinged
	1	487 2448-76	Door complete	Plaque complète	3	Lower Left-hinged
8	1	487 2426-82	•Handle	•Manivelle	3	Complete
9	4	487 2426-36	Bushing	Douille	3	
10	4	487 2426-20	Bushing	Douille	3	
11	1	487 2436-09	Door complete	Plaque complète	3	Upper Right-hinged
	1	487 2448-72	Door complete	Plaque complète	3	Upper Left-hinged
12	4	487 2426-79	Guiding element	Elément de guidage	3	
* 13	4	487 2426-76	Felt sealing	Joint feutre	3	
14	1	487 2439-55	Front	Devant	3	Stainless

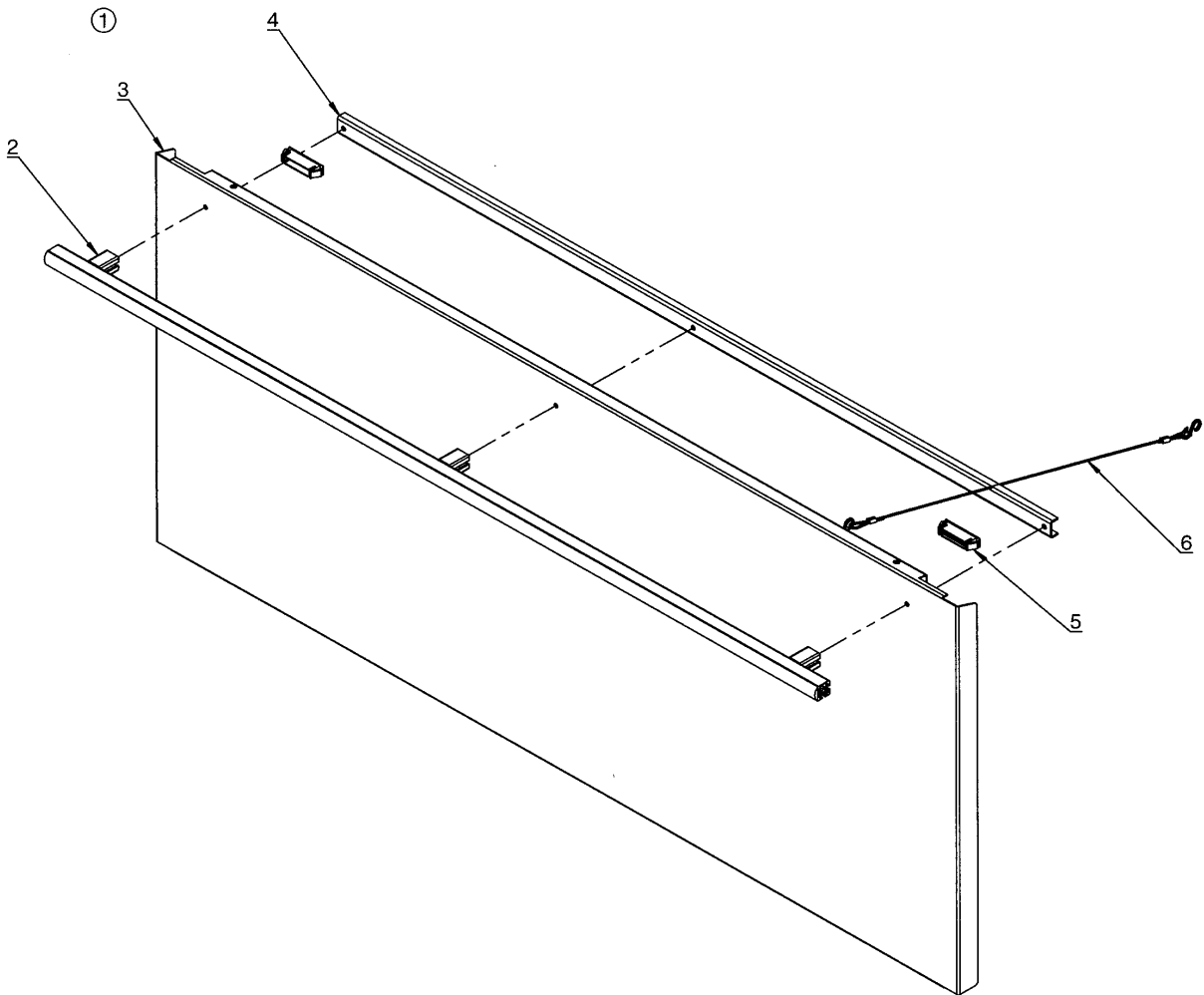

Issue	Month	Year
01	01	04

T3900,TD100

Filter hatch, joined

Plaque filtre, collecté

Illustration Issue Month Year
Schéma Issue Month Year
200126/1 2 4 2004

Item Article	Qua Qua	Art.No Réf. article	Description	Description	Info Info	Notes Remarques
1	1	487 1714-71	Filter hatch	Volet du filtre	3	White Complete
	1	487 1714-72	Filter hatch	Volet du filtre	3	Red Complete
	1	487 1714-73	Filter hatch	Volet du filtre	3	Green Complete
	1	487 1714-74	Filter hatch	Volet du filtre	3	Stainless Complete
	1	487 1714-75	Filter hatch	Volet du filtre	3	Beige Complete
*	1	487 1714-76	Filter hatch	Volet du filtre	3	Ivory Complete
* 2	1	487 1935-74	•Handle	•Manivelle	3	Complete
* 3	1	487 2450-05	•Filter hatch	•Volet du filtre	3	White
*	1	487 2450-06	•Filter hatch	•Volet du filtre	3	Red
*	1	487 2450-41	•Filter hatch	•Volet du filtre	3	Green
*	1	487 2450-55	•Filter hatch	•Volet du filtre	3	Stainless
*	1	487 2450-63	•Filter hatch	•Volet du filtre	3	Beige
*	1	487 2450-77	•Filter hatch	•Volet du filtre	3	Ivory
* 4	1	487 2446-90	•Support	•Support	3	
* 5	2	487 1875-30	•Magnetic lock	•Verrouillage magnétique	3	
* 6	1	487 1974-96	•Steel wire	•Câble métallique	3	Complete

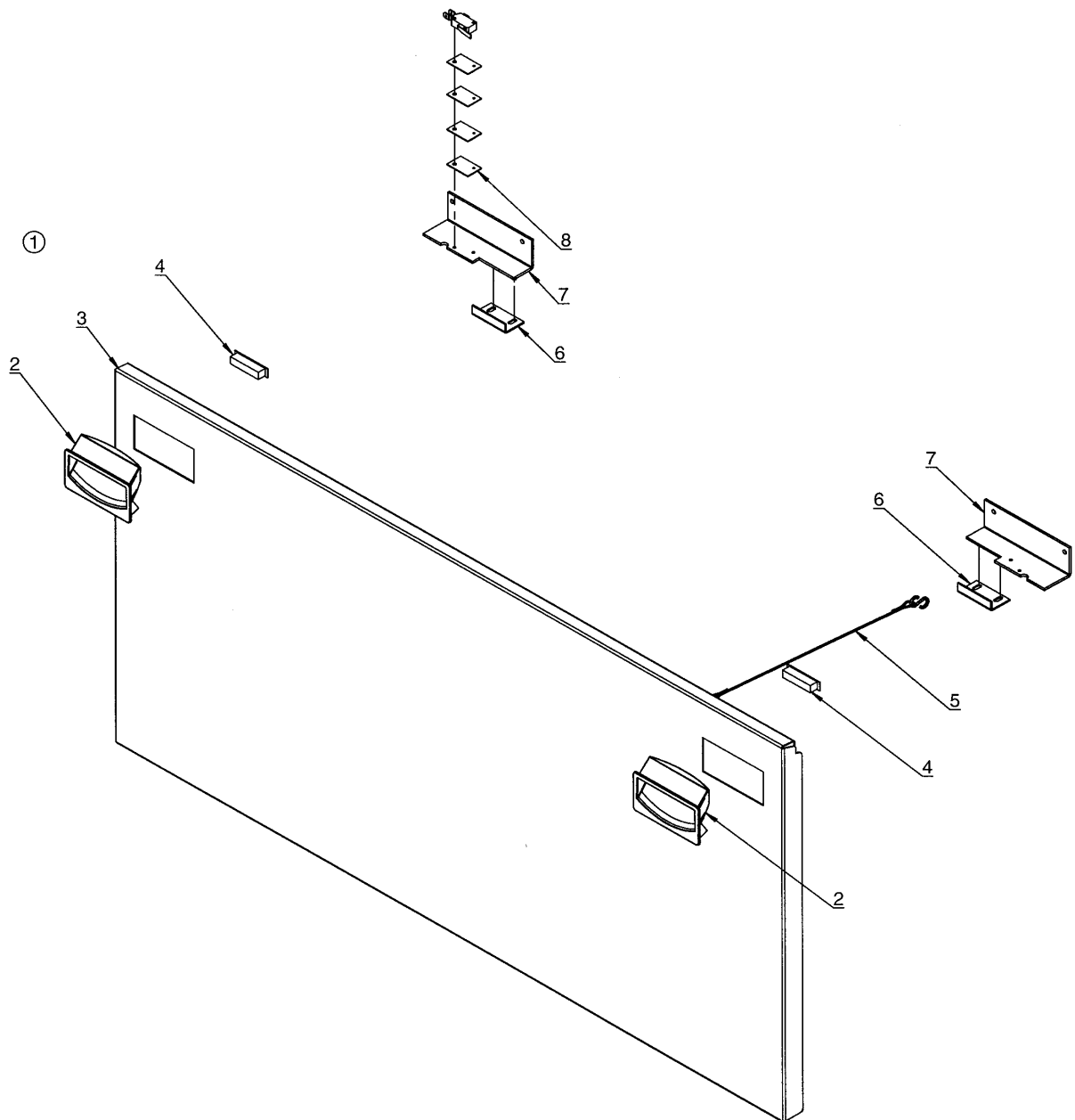

T3900,TD100

Filter hatch, joined - Sliding Door

Plaque filtre, collecté - Sliding Door

Illustration Issue Month Year
Schéma Issue Month Year
200134/1 1 1 2004

Item Article	Qua Qua	Art.No Réf. article	Description	Description	Info Info	Notes Remarques
1	1	487 1935-53	Filter hatch	Volet du filtre	3	Stainless Complete
2	2	487 1920-05	•Handle	•Manivelle	3	Plastic
3	1	487 2427-55	•Filter hatch	•Volet du filtre	3	Stainless
4	2	487 1510-88	•Magnetic lock	•Verrouillage magnétique	3	
5	1	487 1974-96	•Steel wire	•Câble métallique	3	Complete
6	2	487 2447-61	Plate	Plaque	3	Magnet
7	1	487 2426-60	Bracket	Support	3	Left
	1	487 2426-94	Bracket	Support	3	Right
8	4	471 2068-48	Insulation	Isolation	3	
9	1	487 1898-10	Microswitch	Microrupteur	1,2	

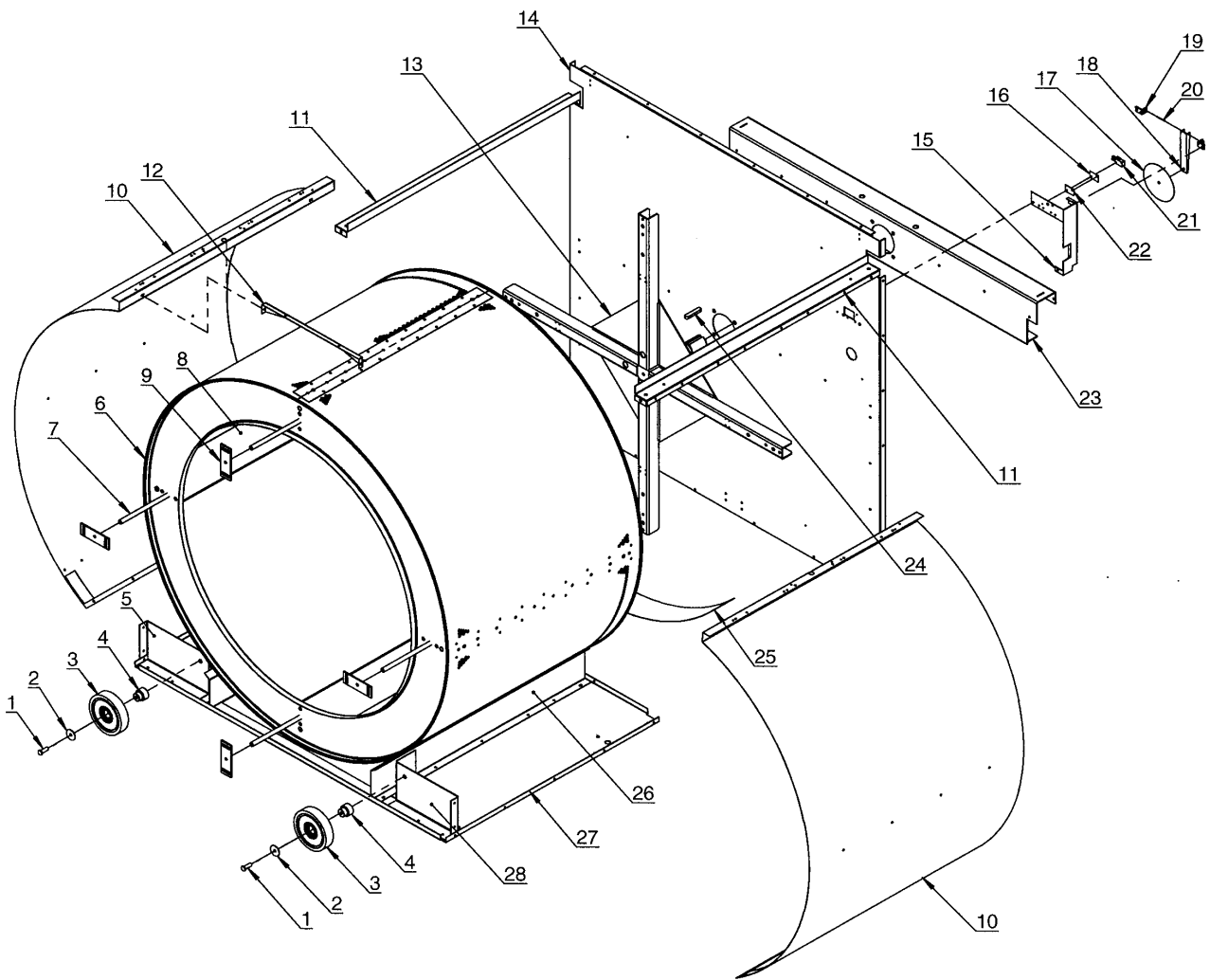

Issue	Month	Year
02	12	03

T3900,T3900 -0401/000113,TD100

Drum, compl.

Tambour, complet

Illustration Issue Month Year
Schéma Issue Month Year
200035/2 2 12 2003

Item Article	Qua Qua	Art.No Réf. article	Description	Description	Info Info	Notes Remarques
1	2	487 1363-01	Bolt	Boulon	3	M8
2	2	487 1694-56	Disc	Disque	3	Ø35X8,5
3	2	487 0098-12	Support roller	Galet de soutien	3	With ball bearing
4	2	487 2400-25	Shaft	Axe	3	
5	1	487 2400-34	Bracket	Console	3	Left
6	1	471 1765-33	Drum	Tambour	3	Galvanised Complete
	1	471 1765-34	Drum	Tambour	3	Stainless Complete
7	4	487 1694-78	•Brace	•Montant	3	
8	4	487 2405-52	•Lifter	•Battoir	3	Stainless
	4	487 2405-62	•Lifter	•Battoir	3	Galvanised
9	4	472 8004-01	•End stop	•Butée	3	
10	2	487 2405-58	Casing	Carter	3	
11	2	487 2405-59	Cable retainer	Support de câble	3	
12	1	487 2400-57	Profile	Profilé d'assemblage	3	
13	1	487 2400-12	Shaft cross	Croix d'arbres	3	
14	1	487 2400-46	Rear panel	Plaque arrière	3	
15	1	487 2255-28	Assembly plate	Plaque de montage	3	
16	1	471 2068-48	Insulation	Isolation	3	
17	1	471 8502-18	Disc	Disque	3	D=123,5
18	1	472 7307-01	Arm	Bras	3	
19	2	472 7308-01	Bracket	Support	3	
20	1	471 7903-03	Shaft	Axe	3	
21	1	487 1897-05	Microswitch	Microrupteur	1,2	
22	1	487 2359-95	Plate	Plaque	3	
23	1	487 2400-40	Cross beam	Poutre transversale		See illustr. 200036
24	1	487 2400-89	Wedge	Cheville	3	A12X8X63
25	1	487 2400-58	Air reducing plate	Tôle de réduction	3	
26	2	487 2405-57	Rail	Rail	3	
27	1	487 2405-56	Top panel	Panneau supérieur		See illustr. 200037
28	1	487 2400-35	Bracket	Console	3	Right

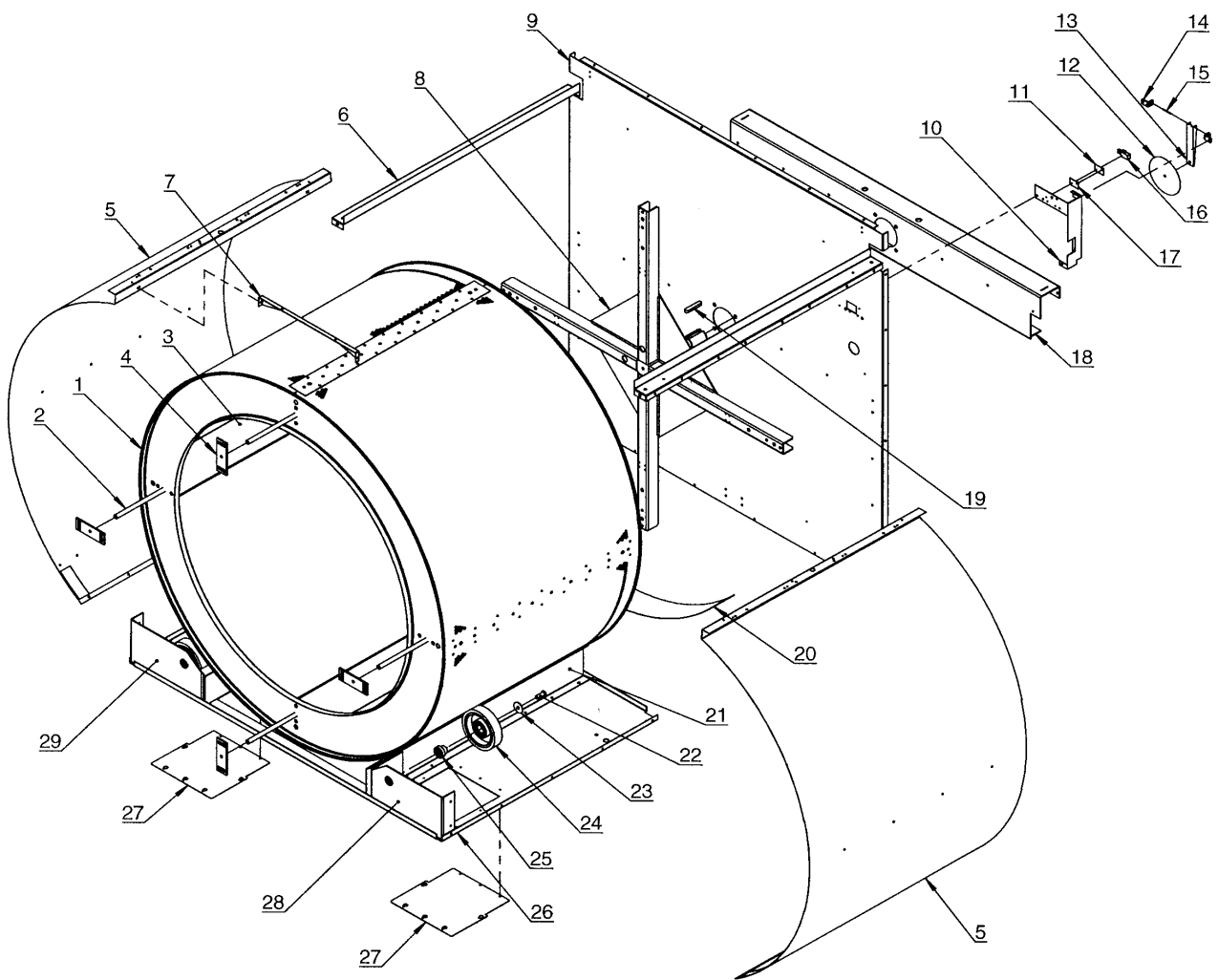

Issue	Month	Year
01	01	04

T3900,T3900 0401/000114-,TD100

Drum, compl.

Tambour, complet

Illustration Issue Month Year
Schéma Issue Month Year
200139/1 1 1 2004

Item Article	Qua Qua	Art.No Réf. article	Description	Description	Info Info	Notes Remarques
1	1	471 1765-33	Drum	Tambour	3	Galvanised Complete
	1	471 1765-34	Drum	Tambour	3	Stainless Complete
2	4	487 1694-78	•Brace	•Montant	3	
3	4	487 2405-52	•Lifter	•Battoir	3	Stainless
	4	487 2405-62	•Lifter	•Battoir	3	Galvanised
4	4	472 8004-01	•End stop	•Butée	3	
5	2	487 2405-58	Casing	Carter	3	
6	2	487 2405-59	Cable retainer	Support de câble	3	
7	1	487 2400-57	Profile	Profilé d'assemblage	3	
8	1	487 2400-12	Shaft cross	Croix d'arbres	3	
9	1	487 2400-46	Rear panel	Plaque arrière	3	
10	1	487 2255-28	Assembly plate	Plaque de montage	3	
11	1	471 2068-48	Insulation	Isolation	3	
12	1	471 8502-18	Disc	Disque	3	D=123,5
13	1	472 7307-01	Arm	Bras	3	
14	2	472 7308-01	Bracket	Support	3	
15	1	471 7903-03	Shaft	Axe	3	
16	1	487 1897-05	Microswitch	Microrupteur	3	
17	1	487 2359-95	Plate	Plaque	3	
18	1	487 2400-40	Cross beam	Poutre transversale	3	
19	1	487 2400-89	Wedge	Cheville	3	A12X8X63
20	1	487 2400-58	Air reducing plate	Tôle de réduction	3	
21	2	487 2405-57	Rail	Rail	3	
22	2	487 1363-01	Bolt	Boulon	3	M8
23	2	487 2422-83	Disc	Disque	3	Ø35XØ10,5X4
24	2	487 0098-12	Support roller	Galet de soutien	3	With ball bearing
25	2	487 2422-82	Shaft	Axe	3	
26	1	487 2405-56	Top panel	Panneau supérieur	3	
27	2	487 2422-84	Cover plate	Tôle de fermeyure	3	
28	1	487 2422-86	Bracket	Console	3	Right
29	1	487 2422-85	Bracket	Console	3	Left

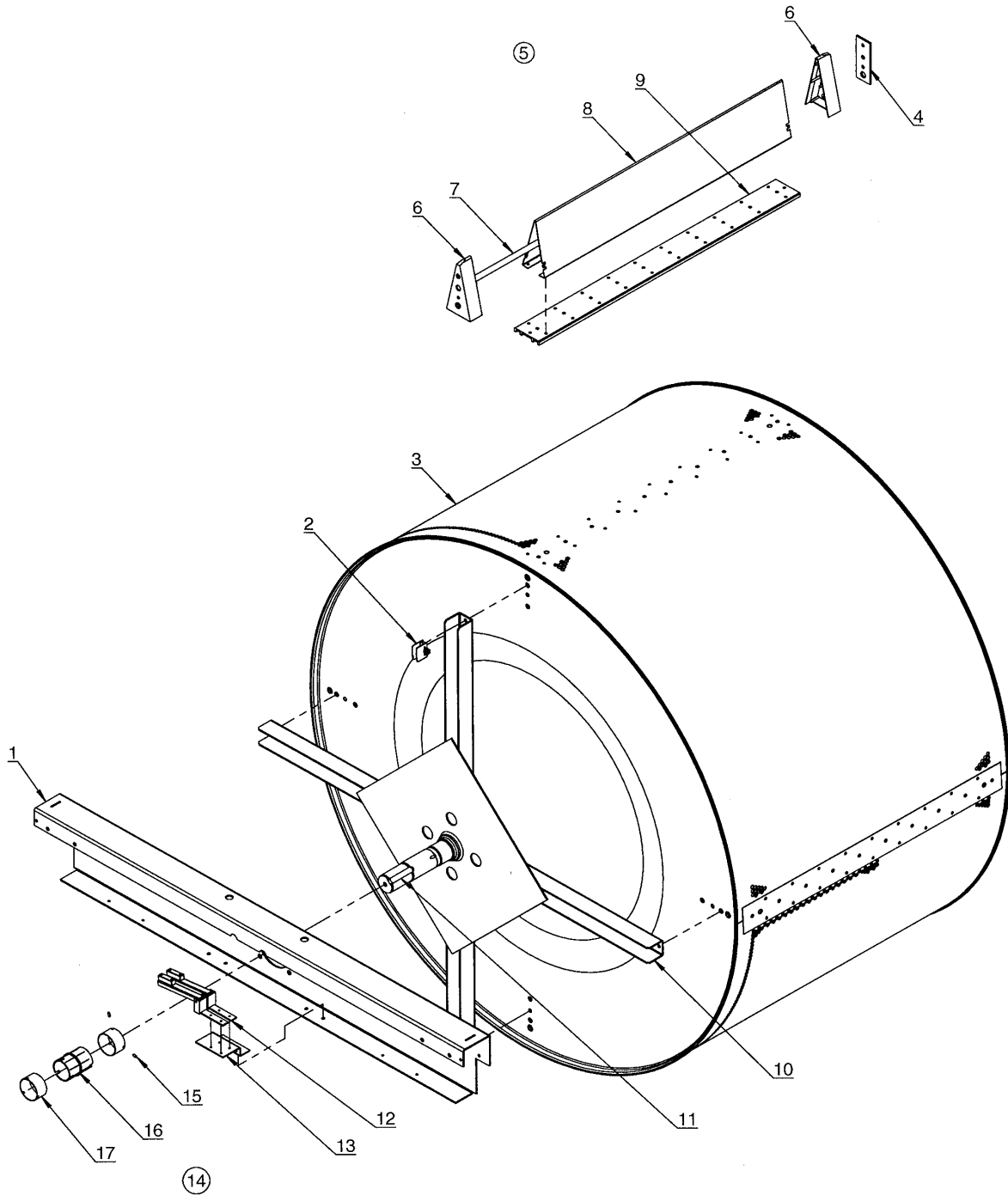

Issue	Month	Year
01	12	03

T3900,TD100

Drum with moisture sensor

Tambour avec capteur humidité

Illustration Issue Month Year
Schéma Issue Month Year
200123/1 1 12 2003

Item Article	Qua Qua	Art.No Réf. article	Description	Description	Info Info	Notes Remarques
1	1	487 2400-40	Cross beam	Poutre transversale	3	
2	1	487 0199-49	Cable set	Ensemble de câbles	3	
3	1	471 1765-35	Drum, compl.	Tambour, complet	3	Galvanised
	1	471 1765-36	Drum, compl.	Tambour, complet	3	Stainless
4	4	487 2408-05	•End stop	•Butée	3	
5	1	487 2408-20	Lifter complete	Battoir complet	3	Galvanised
	1	487 2408-21	Lifter complete	Battoir complet	3	Stainless
6	2	487 2422-72	•End part	•Plaque désenclenchement	3	
7	1	487 2422-75	•Brace	•Montant	3	
8	1	487 2409-13	•Lifter	•Battoir	3	Galvanised
	1	487 2409-14	•Lifter	•Battoir	3	Stainless
9	1	487 2422-73	•Profile	•Profilé	3	
10	1	487 2422-90	Shaft cross	Croix d'arbres	3	
11	1	487 2400-89	Wedge	Cheville	3	A12X8X63
12	2	487 2327-95	Sensor	Détecteur	3	Complete
13	1	487 2427-46	Fitting	Garniture	3	
14	1	487 1831-00	Sensor	Détecteur	3	Complete
15	3	728 5289-00	•Screw	•Vis	3	M4X10
16	1	487 1820-34	•Insulator	•Isolant	3	
17	2	487 1820-35	•Ring	•Anneau	3	

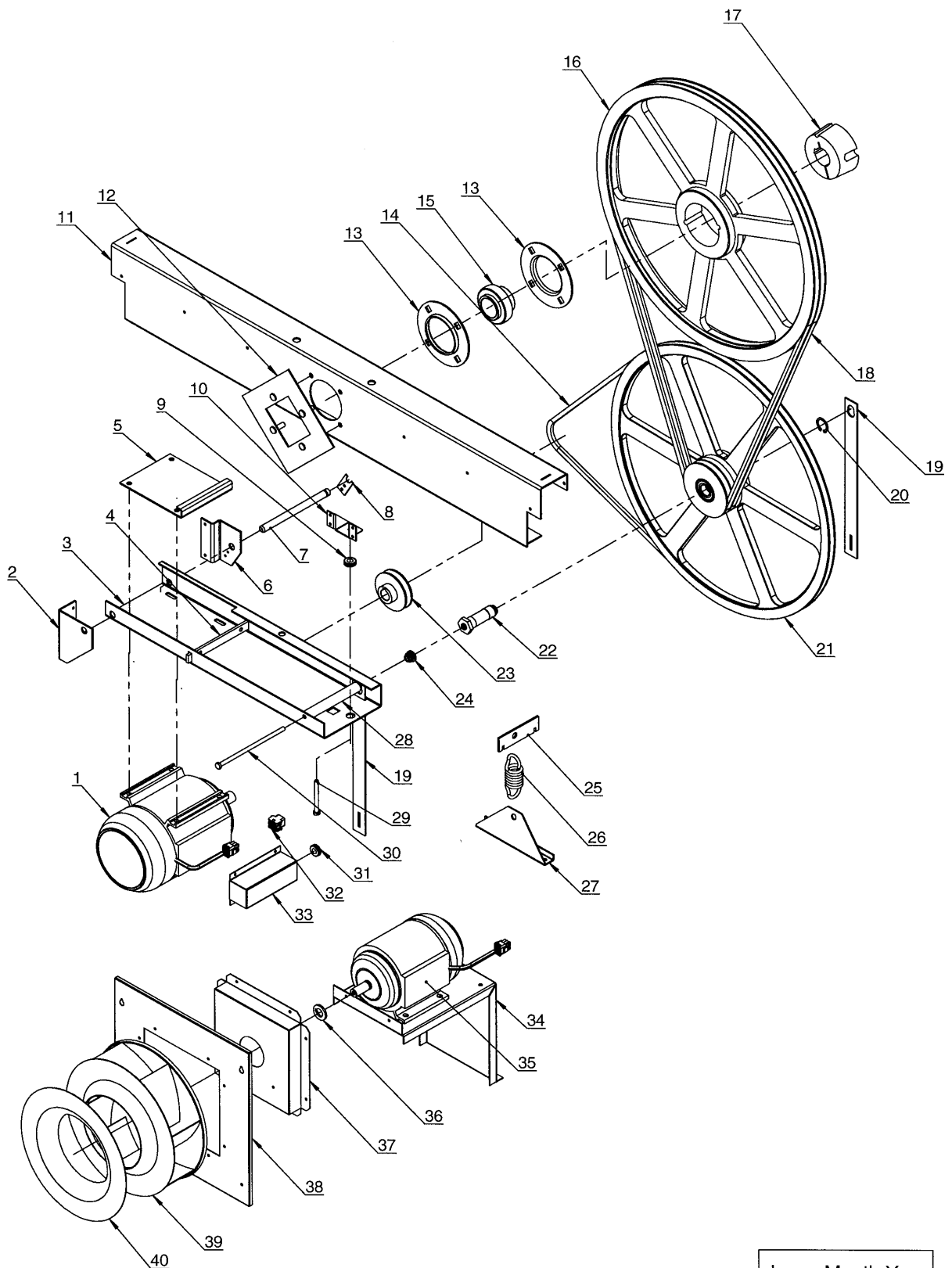

Issue	Month	Year
02	12	03

T3900,TD100

Motor alternative

Alternative moteur

Illustration Issue Month Year
Schéma Issue Month Year
200036/2 4 4 2004

Item Article	Qua Qua	Art.No Réf. article	Description	Description	Info Info	Notes Remarques
1	1	487 0289-33	Motor	Moteur	1,2	Drum
2	1	487 2400-43	Bracket	Console	3	Foremost
3	1	487 2400-52	Motor bracket	Appui de moteur	3	
4	1	487 2400-76	Belt tensioner	Tendeur de courroie	3	
5	1	487 2400-44	Plate	Plaque	3	
6	1	487 2400-39	Bracket	Console	3	Hindmost
7	1	487 2400-37	Shaft	Axe	3	
8	1	487 2400-74	Locking plate	Gâche de serrure	3	
9	1	487 2412-12	Rubber bushing	Douille caoutchouc	3	Ø12/Ø18X3
10	1	487 2400-66	Safety plate	Garniture de sécurité	3	
11	1	487 2400-40	Cross beam	Poutre transversale	3	
12	1	487 2400-55	Suspension	Suspendu	3	
13	1	487 1695-48	Bearing disc	Disque de roulement	3	
14	1	487 2400-83	V-belt	Courroie trapézoïdale	1,2	
15	1	487 1695-49	Bearing	Coussinet	1,2	
16	1	487 2400-81	Pulley	Poulie	3	Ø630
17	1	487 2400-82	Clamping sleeve	Gaine de serrage	3	Ø42
18	2	487 2400-84	V-belt	Courroie trapézoïdale	1,2	
19	2	487 2400-45	Fitting	Garniture	3	
20	1	735 3126-00	C-clamp	Attache en forme C	3	D25
21	1	487 2400-00	Pulley	Poulie	3	With ball bearing
22	1	487 2400-09	Shaft	Axe	3	
23	1	487 2400-08	Pulley	Poulie	3	Ø81 50Hz and frequency controlled
	1	487 2405-66	Pulley	Poulie	3	Ø70 60Hz
24	1	487 2405-01	Bushing	Douille	3	
25	1	487 2400-48	Bracket	Support	3	
26	1	487 2400-98	Spring	Ressort	3	
27	1	487 2400-75	Belt tensioner	Tendeur de courroie	3	
28	1	487 2405-78	Spacer sleeve	Manchon entretoise	3	
29	1	725 2477-51	Screw	Vis	3	M8X130
30	1	487 2400-63	Bolt	Boulon	3	M8X190
31	1	487 1654-06	Rubber bushing	Douille caoutchouc	3	Ø12/Ø18X3
* 32	1	487 0199-10	Cable set	Ensemble de câbles	3	200-240V
* 32	1	487 0199-11	Cable set	Ensemble de câbles	3	400-480V
* 32	1	487 1935-16	Cable	Câble	3	200-240V 3AC Complete Frequency
* 32	1	487 1935-17	Cable	Câble	3	400-480V 3AC Complete Frequency
33	1	487 2405-43	Cover	Couvercle	3	
34	1	487 2400-68	Bracket	Console	3	
35	1	487 0289-89	Motor	Moteur	1,2	
36	1	487 2406-04	Disc	Disque	3	Ø35
37	1	487 2412-19	Cover	Couvercle	3	50/60Hz
38	1	487 2400-64	Cover	Couvercle	3	
39	1	487 2412-02	Fan wheel	Poulie ventilateur	3	50/60Hz
40	1	487 2422-80	Venturi	Venturi	3	Ø315 50/60Hz

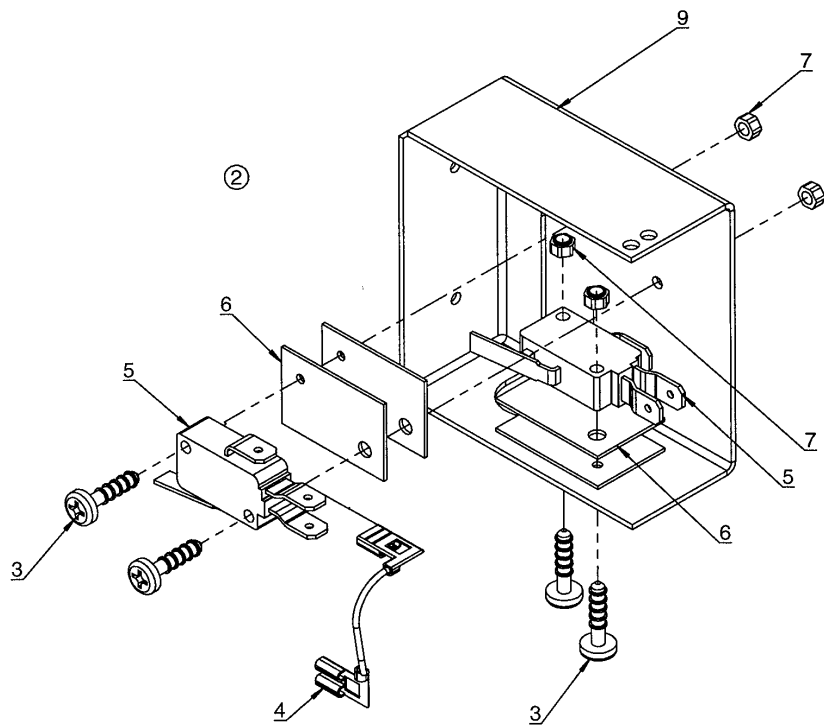
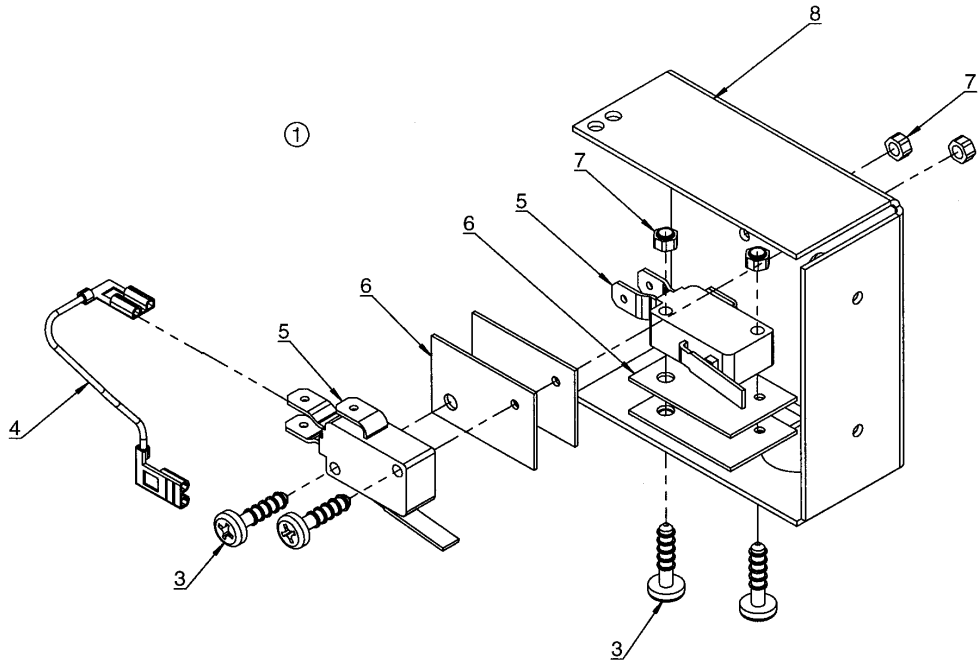

Issue Month Year
01 01 04

T3900,TD100

Door switch - Sliding Door

Interrupteur de porte - Sliding Door

Illustration	Issue	Month	Year
Schéma	Issue	Month	Year
200137/1	1	1	2004

Item Article	Qua Qua	Art.No Réf. article	Description	Description	Info Info	Notes Remarques
1	1	487 2427-21	Door switch	Interrupteur de porte	3	Complete Left-hinged
2	1	487 2427-22	Door switch	Interrupteur de porte	3	Complete Right-hinged
3	4	724 1228-01	•Screw	•Vis		M3X16
4	1	487 0199-16	•Cable	•Câble	3	
5	2	487 1898-10	•Microswitch	•Microrupteur	1,2	
6	8	471 2068-48	•Insulation	•Isolation	3	
7	4	732 2210-01	•Locking nut	•Contre-écrou		M3
8	1	487 2426-03	•Screen	•Écran	3	Left-hinged
9	1	487 2427-23	•Screen	•Écran	3	Right-hinged

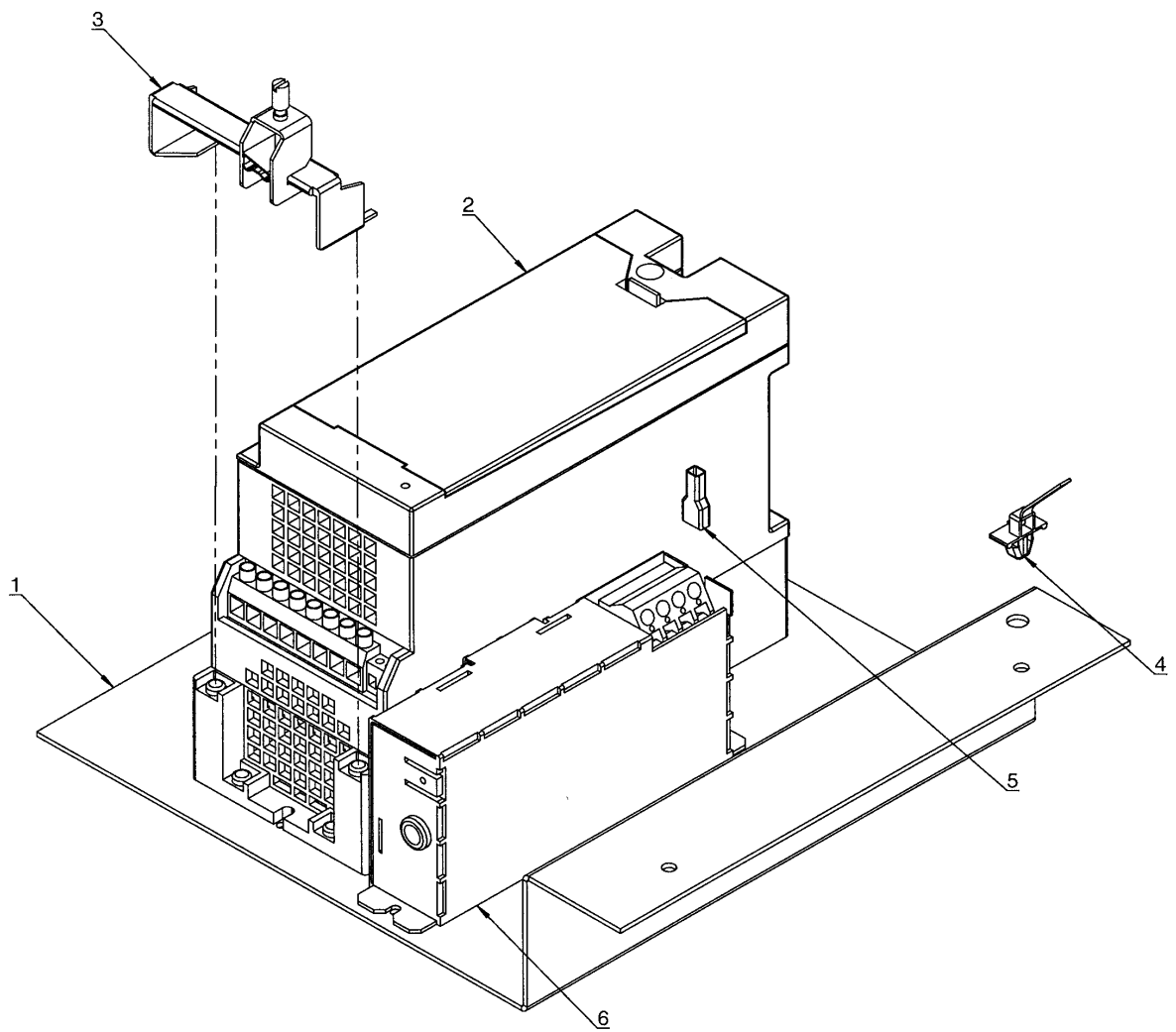

Issue	Month	Year
01	12	03

T3900,TD100

Frequency converter, complete

Convertisseur de fréquence, complet

Illustration	Issue	Month	Year
Schéma	Issue	Month	Year
200098/1	1	12	2003

Item Article	Qua Qua	Art.No Réf. article	Description	Description	Info Info	Notes Remarques
1	1	487 2405-42	Bracket	Support	3	
2	1	487 1935-13	Frequency converter	Convertisseur de fréquence	3	200-240V 1AC
3	1	487 1935-14	Frequency converter	Convertisseur de fréquence	3	400-480V 3AC
3	1	487 0289-60	•Rod linkage	•Biellette	3	
4	1	487 1694-18	Cable tie	Collier de serrage	3	
5	1	487 0199-42	Cable set	Ensemble de câbles	3	
6	1	487 0289-63	Filter	Filtre	3	200-240V 1AC
	1	487 0289-57	Filter	Filtre	3	400-480V 3AC

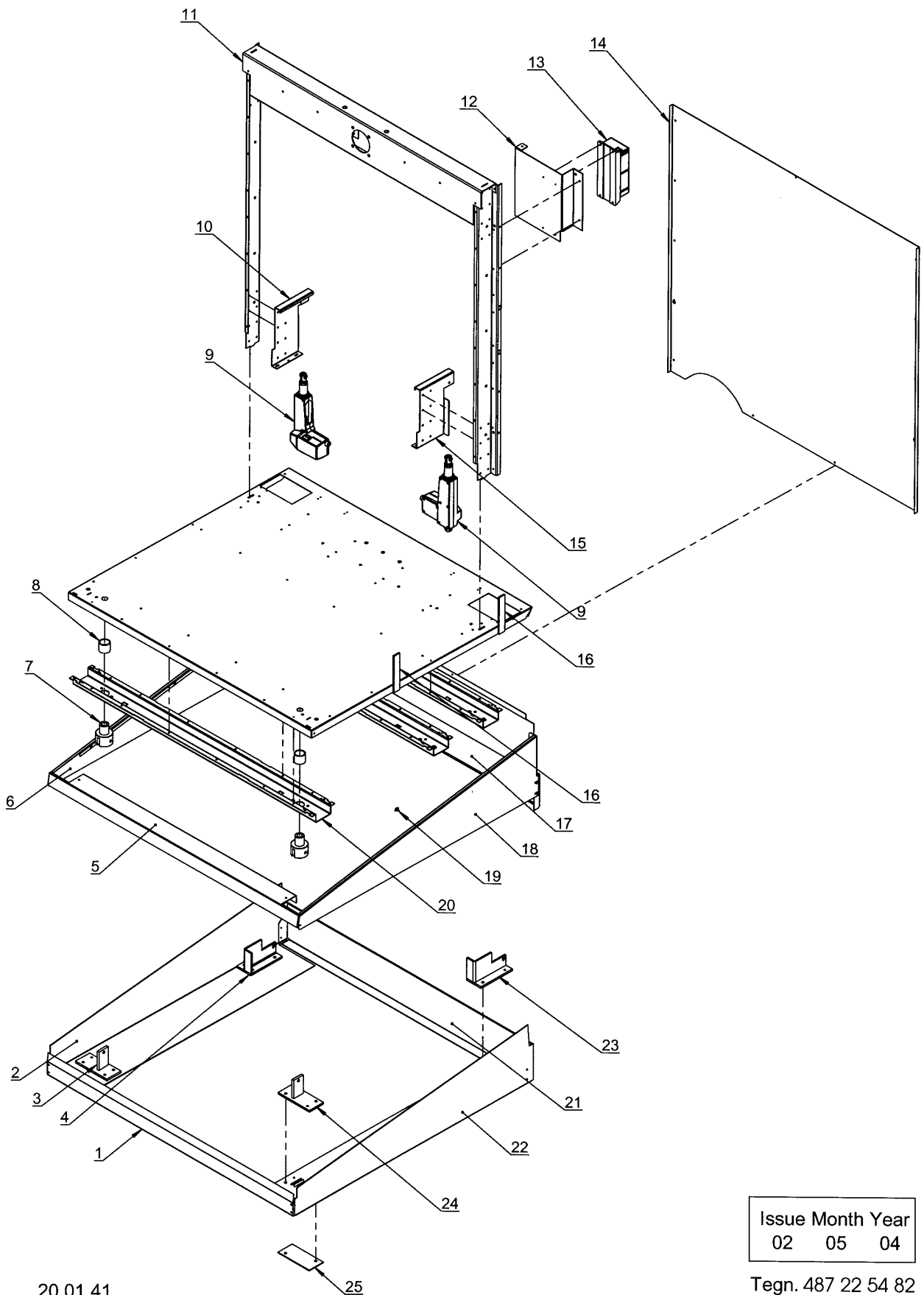

T3900,TD100

Tilt

Inclinaison

Illustration Issue Month Year
Schéma Issue Month Year
200141/1 2 4 2004

Item Article	Qua Qua	Art.No Réf. article	Description	Description	Info Info	Notes Remarques
1	1	487 2436-55	Front	Devant	3	Socket
2	1	487 2427-91	Socket	Socle	3	Complete Left
3	1	487 2427-87	•Foot	•Pied	3	Foremost
4	1	487 2427-86	•Foot	•Pied	3	Left Hindmost
5	1	487 2401-55	Cross beam	Poutre transversale	3	Bottom
6	1	487 2427-93	Side	Côté	3	Left Inner box
7	2	487 2426-05	Bracket	Console	3	
8	2	487 2427-62	Bushing	Douille	3	
9	2	487 1935-72	Activator	Activateur	3	Complete
10	1	487 2427-83	Fitting	Garniture	3	Left
11	1	487 2400-40	Cross beam	Poutre transversale		See illustr. 200035, 200036, 200139
12	1	487 2436-05	Fitting	Garniture	3	
13	1	487 0289-87	Control box	Boîtier de contrôle	3	120V
	1	487 0289-99	Control box	Boîtier de contrôle	3	230V
14	1	487 2427-76	Rear panel	Plaque arrière	3	
15	1	487 2427-82	Fitting	Garniture	3	Right
16	1	487 2427-69	Felt	Feutre	3	5X30 MM
17	1	487 2429-55	Rear panel	Plaque arrière	3	Inner box
18	1	487 2427-92	Side	Côté	3	Right Inner box
* 19	8	487 2427-96	Clips-screw	Clips-vis	3	M5X10
* 20	2	487 2427-20	Beam	Poutre	3	
* 21	1	487 2437-55	Rear panel	Plaque arrière	3	Socket
* 22	1	487 2427-90	Socket	Socle	3	Complete Right
* 23	1	487 2427-85	•Foot	•Pied	3	Hindmost Right
* 24	1	487 2427-87	•Foot	•Pied	3	Foremost
* 25	5	487 2427-25	Adjuster plate	Plaque de réglage	3	1MM
*	5	487 2427-26	Adjuster plate	Plaque de réglage	3	2MM
*	5	487 2427-27	Adjuster plate	Plaque de réglage	3	3MM

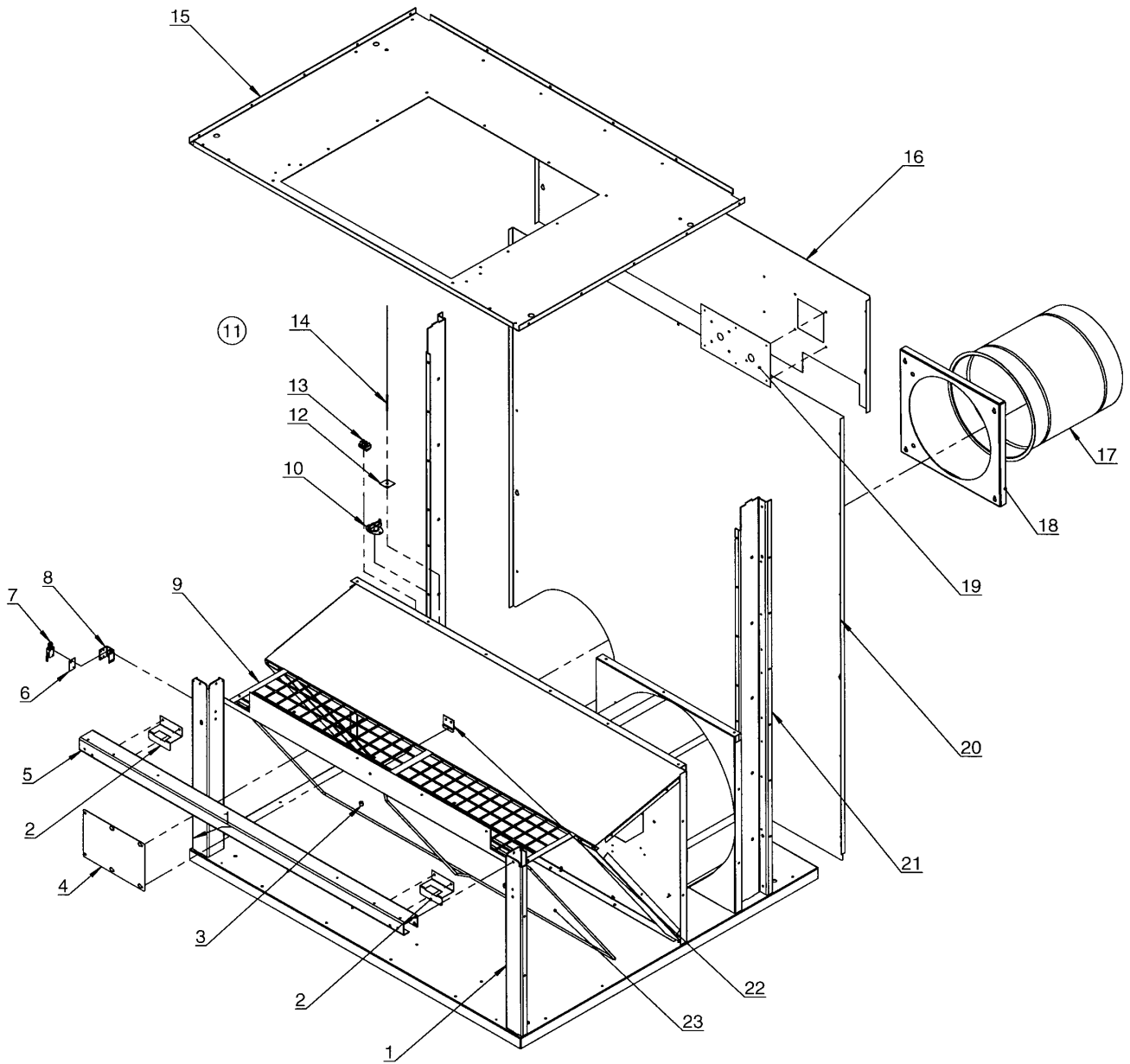

Issue	Month	Year
01	03	03

T3900,TD100

Filter/ Fan housing

Filtre/ Boîtier de ventilateur

Illustration Issue Month Year
Schéma Issue Month Year
200037/1 1 3 2003

Item Article	Qua Qua	Art.No Réf. article	Description	Description	Info Info	Notes Remarques
1	2	487 2400-26	Post	Montant	3	Foremost
2	2	487 2400-70	Angle	Coude	3	
3	2	472 7414-01	Spacer sleeve	Manchon entretoise	3	Ø10/Ø6
4	1	487 2256-07	Cover plate	Plaque recouvrement	3	
5	1	487 2400-33	Beam	Poutre	3	
6	1	471 2068-48	Insulation	Isolation	3	
7	1	487 1898-10	Microswitch	Microrupteur	1,2	
8	1	487 1813-10	Bracket	Support	3	
9	1	487 2400-79	Finger protection	Protection pour les doigts	3	
10	1	487 2317-84	Thermostat	Thermostat	1,2	90°C
11	1	487 1934-71	Thermistor element	Élément thermistor	1,2	Complete
12	1	487 1694-58	•Bracket	•Support	3	
13	1	762 7202-57	•Terminal block	•Borne de raccordement	3	2-pol
14	1	487 1535-04	•Thermistor element	•Élément thermistor	1,2	
15	1	487 2405-56	Top panel	Panneau supérieur	3	
16	1	487 2400-69	Rear panel	Plaque arrière	3	Upper
17	1	487 2405-97	Pipe	Tube	3	
18	1	487 2400-80	Flange	Bride	3	
19	1	487 2405-96	Plate	Plaque	3	
20	1	487 2400-72	Rear panel	Plaque arrière	3	Lower
21	2	487 2400-38	Post	Montant	3	Hindmost
22	1	487 2405-41	Bracket	Support	3	
23	1	487 0101-30	Lint screen	Écran en coton	3	

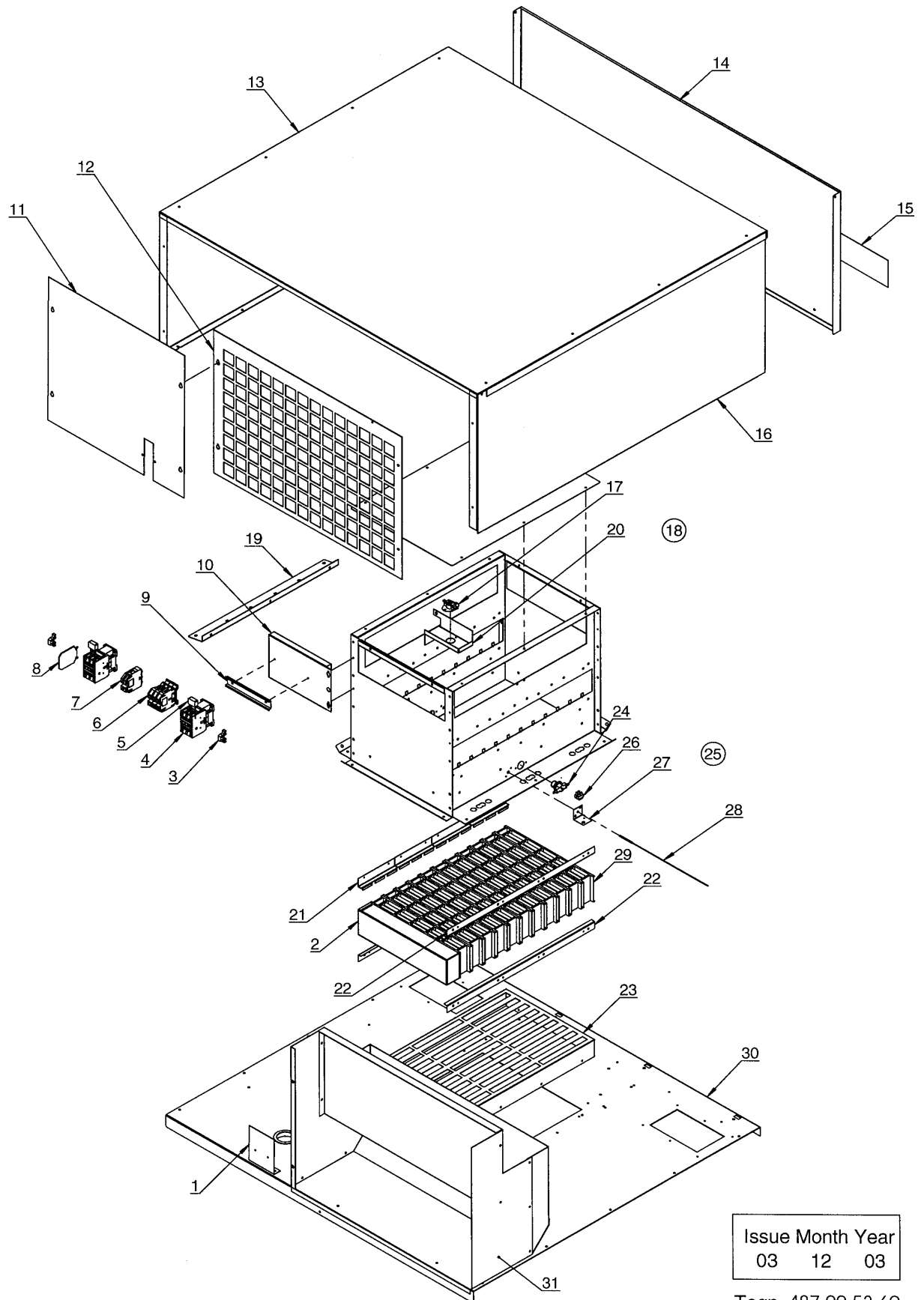

T3900,TD100

Heater unit, el

Élément chauffant, el

Illustration Issue Month Year
Schéma Issue Month Year
200038/3 3 1 2004

Item Article	Qua Qua	Art.No Réf. article	Description	Description	Info Info	Notes Remarques
1	1	487 2405-32	Cover	Couvercle	3	
2	RQ	487 1781-19	Air reducing plate	Tôle de réduction	3	
3	2	487 1384-04	End stop	Butée	3	
4	2	438 9637-31	Relay	Relais	1,2	
5	2	487 0289-17	RC-unit	Diode RC	1,2	
6	3	487 2217-24	Terminal block	Borne de raccordement	1,2	
7	1	487 0289-23	Ground terminal	Borne de terre	3	
8	1	487 2217-25	End plate	Panneau arrière	3	
9	1	487 0289-35	Rail	Rail	3	
10	1	487 2405-27	Bracket	Support	3	
11	1	487 2411-62	Cover plate	Plaque recouvrement	3	
12	1	487 2411-65	Rear panel	Plaque arrière	3	
13	1	487 2414-05	Top panel	Panneau supérieur	3	White
	1	487 2414-40	Top panel	Panneau supérieur	3	Grey
	1	487 2414-55	Top panel	Panneau supérieur	3	Stainless
14	1	487 2411-05	Front plate	Tôle de façade	3	White
	1	487 2411-06	Front plate	Tôle de façade	3	Red
	1	487 2411-41	Front plate	Tôle de façade	3	Green
	1	487 2411-55	Front plate	Tôle de façade	3	Stainless
	1	487 2411-67	Front plate	Tôle de façade	3	Ivory
	1	487 2411-73	Front plate	Tôle de façade	3	Beige
15	1	487 2226-45	Type plate	Numéro série plaque	3	Wascomat TD100
16	2	487 2410-15	Side plate	Plaque de côté	3	White
	2	487 2410-50	Side plate	Plaque de côté	3	Stainless
	2	487 2410-80	Side plate	Plaque de côté	3	Grey
17	1	487 1697-08	Overheat protection	Protection supérieure	1,2	175°C
18	1	487 1714-93	Box	Caisse	3	Complete
19	1	487 2405-28	•Cable retainer	•Support de câble	3	
20	1	487 1781-22	•Bracket	•Console	3	
21	4	487 2255-15	•Bracket	•Support	3	
22	3	487 2405-25	•Rail	•Rail	3	
23	1	487 2405-37	•Grating	•Claie	3	
24	1	487 1697-08	•Overheat protection	•Protection supérieure	1,2	175°C
25	1	487 2408-33	Thermistor element	Élément thermistor	1,2	Complete
26	1	762 7202-57	•Terminal block	•Borne de raccordement	3	2-pol
27	1	487 2406-00	•Fitting	•Garniture	3	
28	1	487 1535-04	•Thermistor element	•Élément thermistor	1,2	
29	RQ	487 1531-61	Heating element	Élément chauffant	1,2	230V 6kW
	RQ	487 1531-62	Heating element	Élément chauffant	1,2	240V 6kW
	RQ	487 1531-63	Heating element	Élément chauffant	1,2	440V 6kW
	RQ	487 1531-68	Heating element	Élément chauffant	1,2	480V 6kW
	RQ	487 1531-73	Heating element	Élément chauffant	1,2	230V 8kW
	RQ	487 1531-75	Heating element	Élément chauffant	1,2	240V 8kW
	RQ	487 1531-74	Heating element	Élément chauffant	1,2	254V 8kW
	RQ	487 1531-76	Heating element	Élément chauffant	1,2	277V 8kW
30	1	487 2405-65	Top panel	Panneau supérieur		See illustr. 200033
31	1	487 1714-95	Labyrinth	Labyrinthe	3	Complete

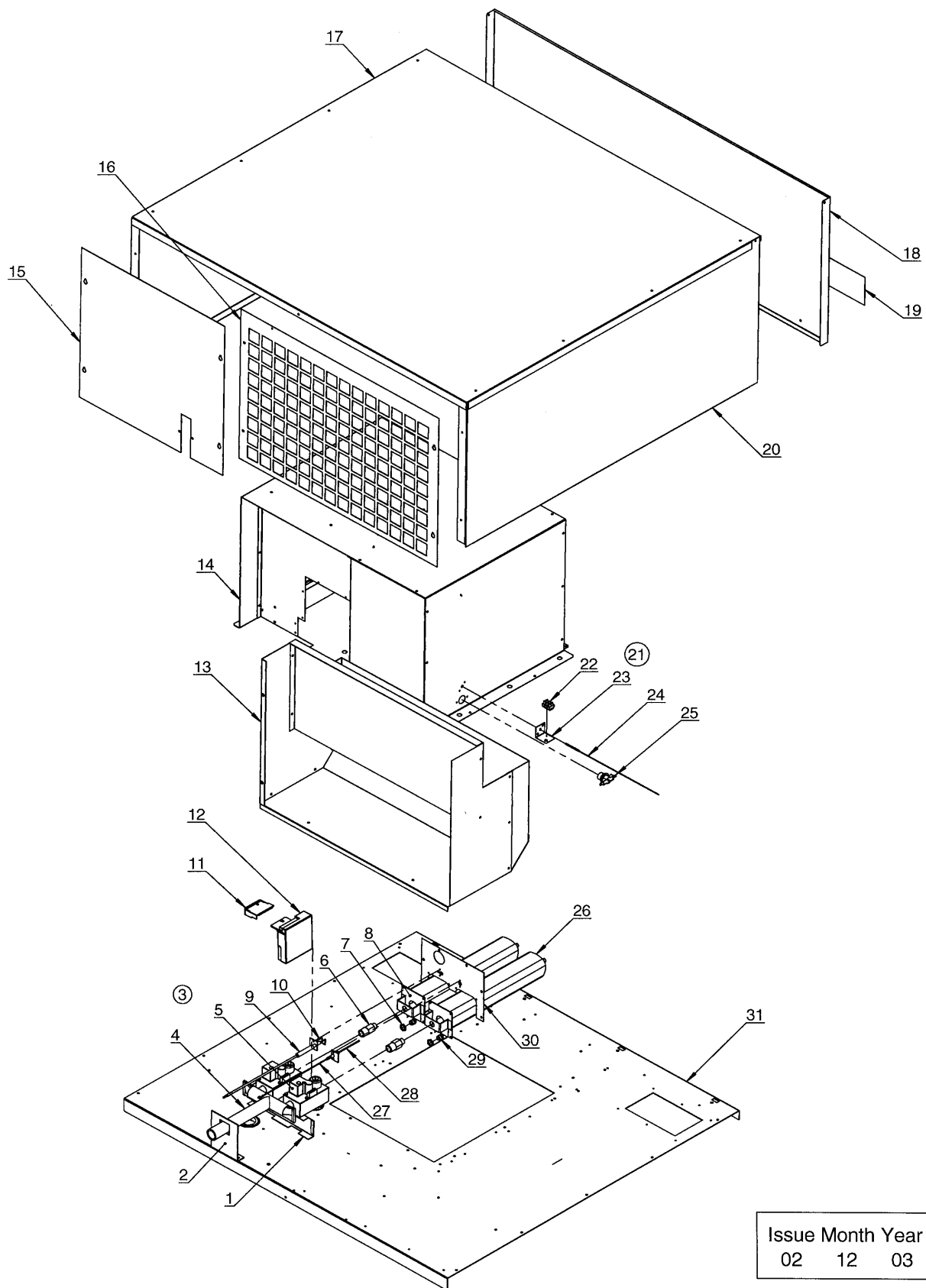

Issue	Month	Year
02	12	03

T3900,TD100

Heater unit, gas

Élément chauffant, gaz

Illustration Issue Month Year
Schéma Issue Month Year
200039/2 2 12 2003

Item Article	Qua Qua	Art.No Réf. article	Description	Description	Info Info	Notes Remarques
1	1	487 2400-95	Bracket	Support	3	
2	1	487 2400-97	Bracket	Support	3	
3	1	487 2408-36	Valve with pipe	Soupape avec tube	3	Complete
	1	487 2408-38	Valve with pipe	Soupape avec tube	3	Complete TD100
4	1	487 2405-15	•Pipe	•Tube	3	
	1	487 2408-39	•Pipe	•Tube	3	TD100
5	2	487 1437-25	•Gas valve	•Vanne de gaz	3	110V
6	2	487 1764-14	•Nipple	•Raccord	3	1/2"- 3/8"
7	2	471 8400-06	•Nut	•Écrou	3	R3/8" 22NV H5
8	2	487 1533-95	•Air reducing plate	•Tôle de réduction	3	Ø35
	2	487 1533-96	Air reducing plate	Tôle de réduction	3	Ø40 GN/GNH/GNL
	2	487 1533-97	Air reducing plate	Tôle de réduction	3	Ø32 GLP
9	1	487 0068-27	Ignition cable	Câble d'allumage	3	Gnist
10	1	487 0068-20	Elektrode	Électrode	3	
11	1	487 1438-21	Cover	Capot	3	
12	1	487 1438-25	Control box	Boîtier de contrôle	3	110V
13	1	487 1714-97	Labyrinth	Labyrinthe	3	Complete
14	1	487 1714-94	Box	Caisse	3	Complete
15	1	487 2411-62	Cover plate	Plaque recouvrement	3	
16	1	487 2411-65	Rear panel	Plaque arrière	3	
17	1	487 2414-05	Top panel	Panneau supérieur	3	White
	1	487 2414-40	Top panel	Panneau supérieur	3	Grey
	1	487 2414-55	Top panel	Panneau supérieur	3	Stainless
18	1	487 2411-05	Front plate	Tôle de façade	3	White
	1	487 2411-06	Front plate	Tôle de façade	3	Red
	1	487 2411-41	Front plate	Tôle de façade	3	Green
	1	487 2411-55	Front plate	Tôle de façade	3	Stainless
	1	487 2411-67	Front plate	Tôle de façade	3	Ivory
	1	487 2411-73	Front plate	Tôle de façade	3	Beige
19	1	487 2226-45	Type plate	Numéro série plaque	3	Wascomat TD100
20	2	487 2410-15	Side plate	Plaque de côté	3	White
	2	487 2410-50	Side plate	Plaque de côté	3	Stainless
	2	487 2410-80	Side plate	Plaque de côté	3	Grey
21	1	487 2408-33	Thermistor element	Élément thermistor	1,2	Complete
22	1	762 7202-57	•Terminal block	•Borne de raccordement	3	2-pol
23	1	487 2406-00	•Fitting	•Garniture	3	
24	1	487 1535-04	•Thermistor element	•Élément thermistor	1,2	
25	1	487 1697-08	Overheat protection	Protection supérieure	1,2	175°C
26	2	487 2405-18	Gas burner	Radiateur à gaz	3	
27	1	487 1934-50	Cable	Câble	3	
28	1	487 0068-28	Sensor	Détecteur	3	
29	2	471 9853-68	Nozzle	Buse	3	Ø3,3 GLP
	2	471 9853-76	Nozzle	Buse	3	Ø4,7 GN
	2	471 9853-49	Nozzle	Buse	3	Ø5,65 GNH
	2	471 9853-84	Nozzle	Buse	3	Ø6,2 GNL
30	1	487 2400-90	Bracket	Support	3	
31	1	487 2405-65	Top panel	Panneau supérieur		See illustr. 200033

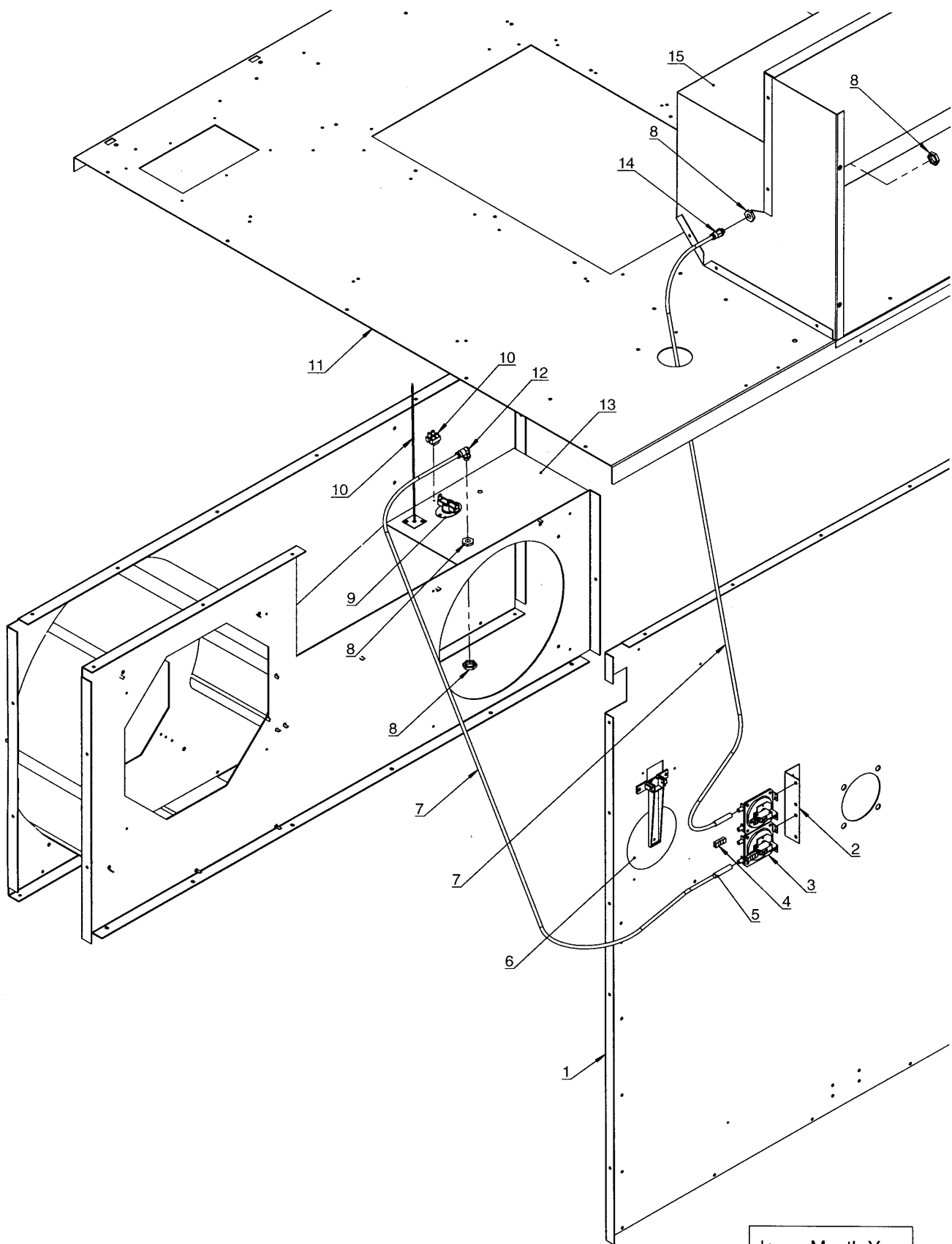

Issue Month Year
01 01 04

T3900,TD100

Gas components - Australia

Composants gaz - Australie

Illustration Issue Month Year
Schéma Issue Month Year
200144/1 1 1 2004

Item Article	Qua Qua	Art.No Réf. article	Description	Description	Info Info	Notes Remarques
1	1	487 2400-46	Rear panel	Plaque arrière		See illustr. 200035, 200139
2	1	487 2330-10	Fitting	Garniture	3	
3	2	487 2330-11	Pressostat	Pressostat	3	
4	1	487 0324-71	Cable	Câble	3	
5	2	487 7056-53	Flexible hose	Flexible	3	Silicone rubber
6	1	487 2328-85	Vacuum switch	Commutateur de vide		Complete See illustr. 200035, 200139
7	2	487 2330-13	Hose	Flexible	3	3,5M Nylon
8	2	487 2330-14	Gromet	Oeillet	3	
9	1	487 2317-84	Thermostat	Thermostat	1,2	90°C
10	1	487 1934-71	Thermistor element	Élément thermistor		Complete See illustr. 200037
11	1	487 2405-65	Top panel	Panneau supérieur		See illustr. 200033, 200038, 200039, 200040
12	1	487 2330-15	Angle	Coude	3	90°
13	1	487 2408-75	Fan housing	Boîtier de ventilateur		See illustr. 200037
14	1	487 2330-16	Joint piece	Raccord	3	Ø6,1/ 8"
15	1	487 1714-97	Labyrinth	Labyrinthe		Complete See illustr. 200039

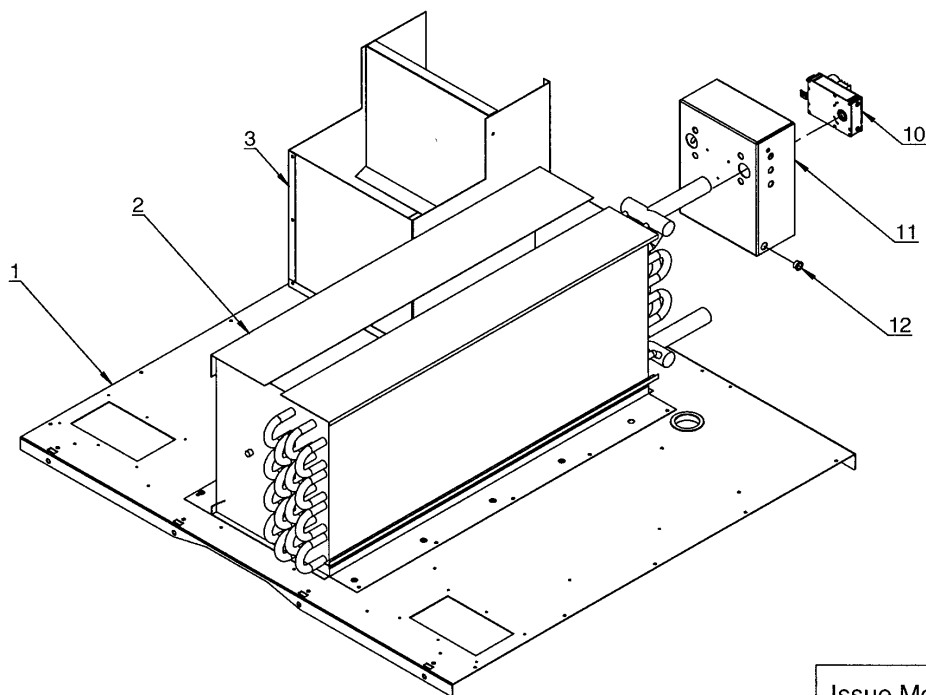
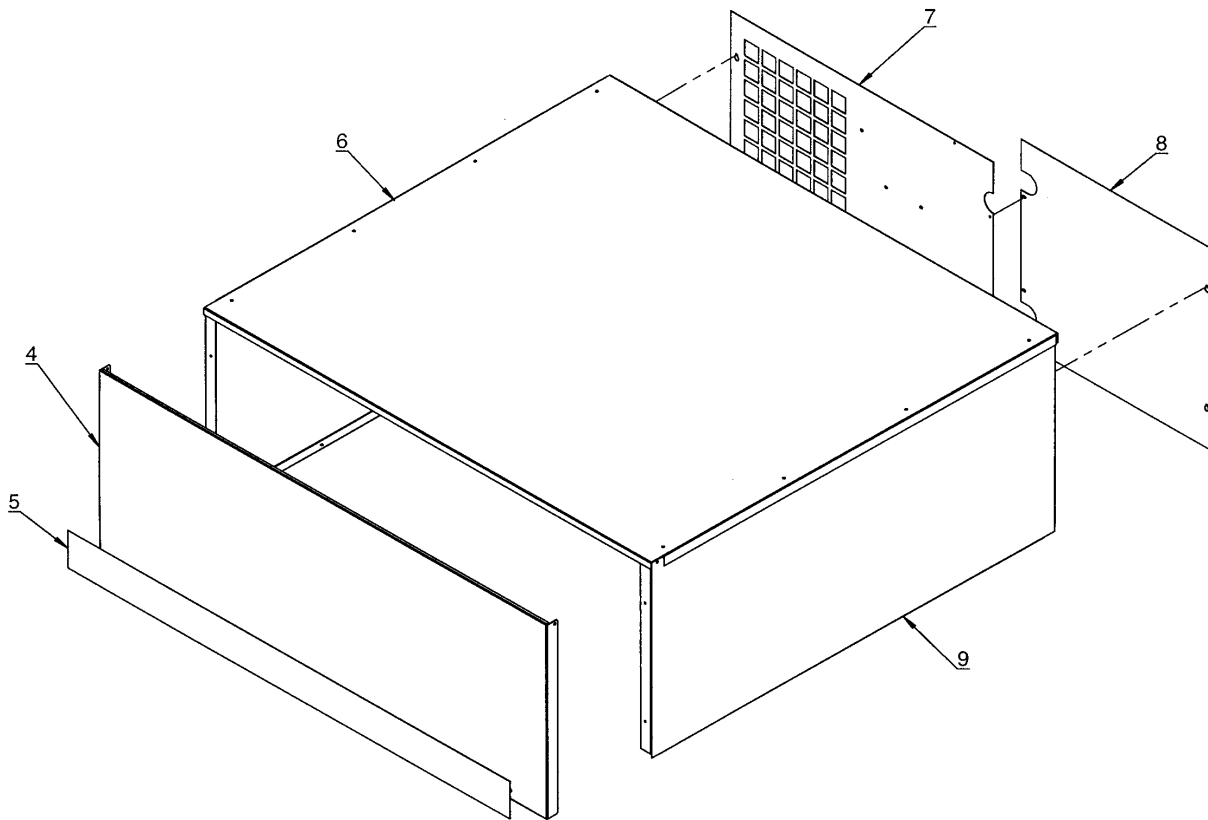

Issue	Month	Year
02	12	03

T3900,TD100

Heating unit, steam

Unité chauffage, vapeur

Illustration Issue Month Year
Schéma Issue Month Year
200040/2 2 12 2003

Item Article	Qua Qua	Art.No Réf. article	Description	Description	Info Info	Notes Remarques
1	1	487 2405-65	Top panel	Panneau supérieur		See illustr. 200033
2	1	487 2405-90	Heating element	Élément de chauffage	3	
3	1	487 1714-96	Labyrinth	Labyrinthe	3	Complete
4	1	487 2411-05	Front plate	Tôle de façade	3	White
	1	487 2411-06	Front plate	Tôle de façade	3	Red
	1	487 2411-41	Front plate	Tôle de façade	3	Green
	1	487 2411-55	Front plate	Tôle de façade	3	Stainless
	1	487 2411-67	Front plate	Tôle de façade	3	Ivory
	1	487 2411-73	Front plate	Tôle de façade	3	Beige
5	1	487 2226-45	Type plate	Numéro série plique	3	Wascomat TD100
6	1	487 2414-05	Top panel	Panneau supérieur	3	White
	1	487 2414-40	Top panel	Panneau supérieur	3	Grey
	1	487 2414-55	Top panel	Panneau supérieur	3	Stainless
7	1	487 2411-64	Rear panel	Plaque arrière	3	
8	1	487 2411-63	Cover plate	Plaque recouvrement	3	
9	2	487 2410-15	Side plate	Plaque de côté	3	White
	2	487 2410-50	Side plate	Plaque de côté	3	Stainless
	2	487 2410-80	Side plate	Plaque de côté	3	Grey
10	1	487 1781-51	Damper motor	Moteur amortisseur	1,2	
11	1	487 2405-91	Cover	Couvercle	3	
12	1	762 1137-10	Cable gland	Passe-fil	3	Ø18

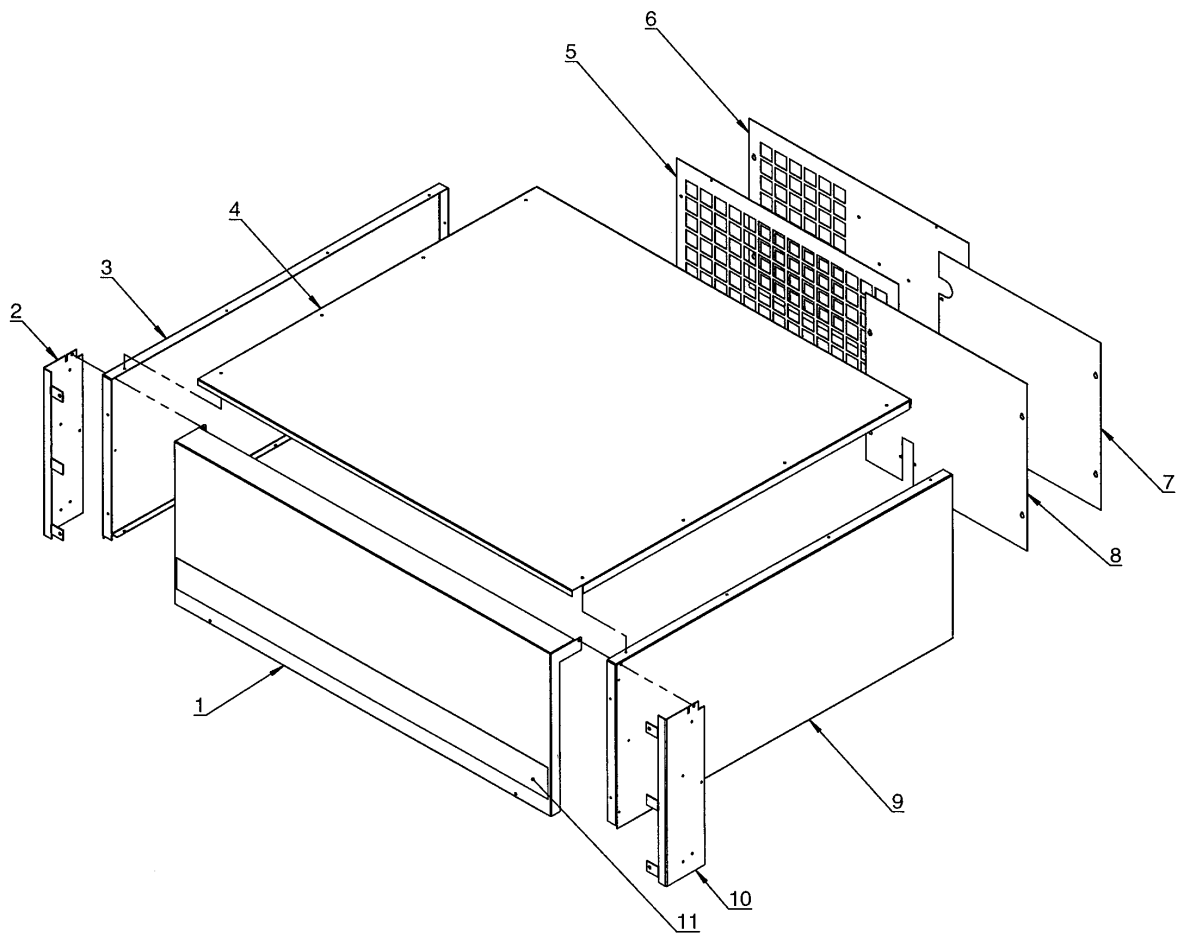

T3900,TD100

Box - heating unit Sliding Door

Caise - unite chauffage Sliding Door

Illustration Issue Month Year
Schéma Issue Month Year
200138/1 1 1 2004

Item Article	Qua Qua	Art.No Réf. article	Description	Description	Info Info	Notes Remarques
1	1	487 2438-55	Front	Devant	3	Stainless
2	1	487 2426-01	Panel	Panneau	3	Left
3	1	487 2443-05	Side	Côté	3	White Left
	1	487 2443-40	Side	Côté	3	Grey Left
4	1	487 2414-05	Top panel	Panneau supérieur	3	White
	1	487 2414-40	Top panel	Panneau supérieur	3	Grey
5	1	487 2411-65	Rear panel	Plaque arrière	3	Electric + gas
6	1	487 2411-64	Rear panel	Plaque arrière	3	Steam
7	1	487 2411-63	Cover plate	Plaque recouvrement	3	Steam
8	1	487 2411-62	Cover plate	Plaque recouvrement	3	Electric + gas
9	1	487 2442-05	Side	Côté	3	White Right
	1	487 2442-40	Side	Côté	3	Grey Right
10	1	487 2426-00	Panel	Panneau	3	Right
11	1	487 2226-45	Type plate	Numéro série plaque	3	Wascomat TD100

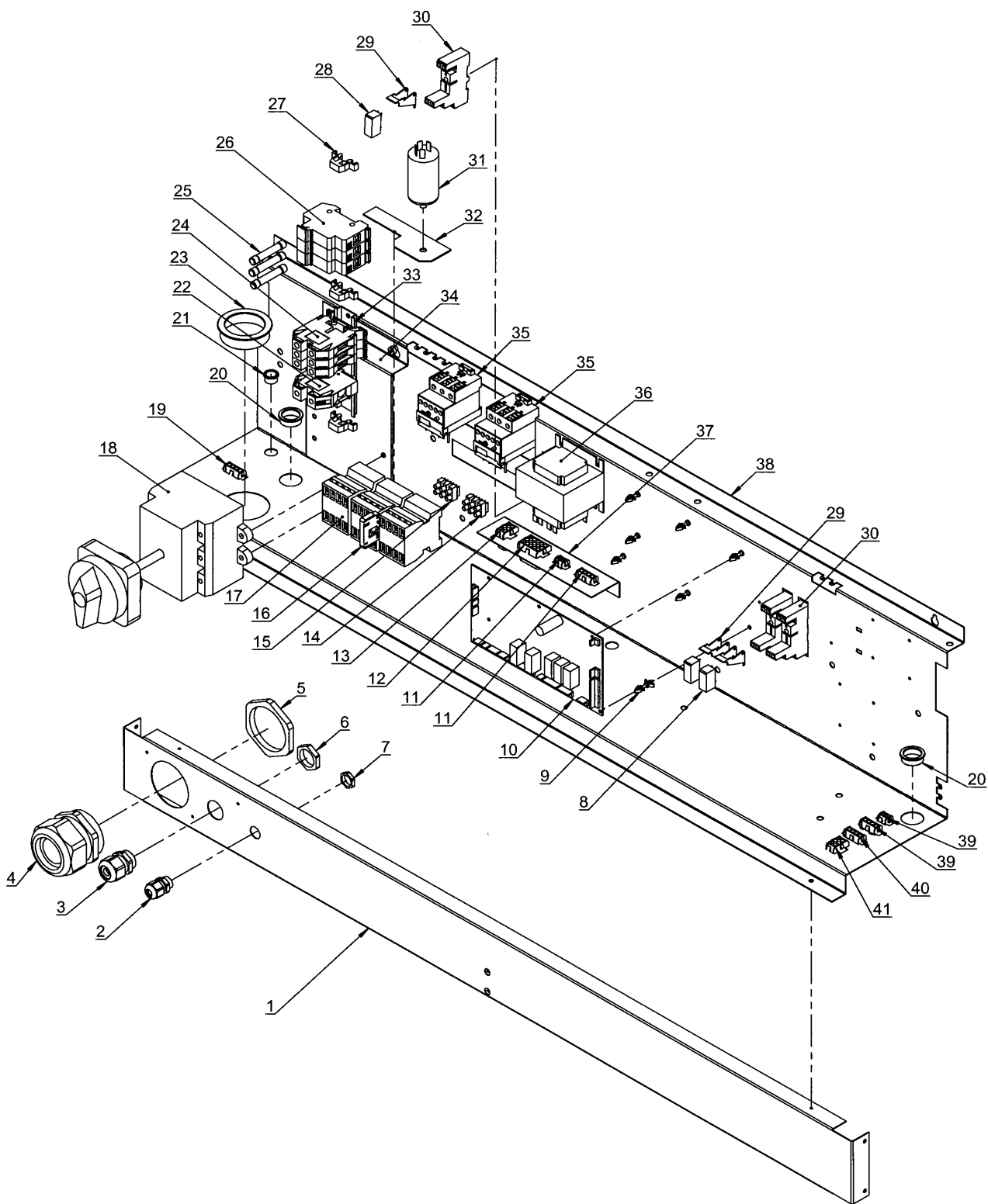

Issue	Month	Year
03	05	04

T3900,TD100

Connection unit, el

Connexion, électrique

Illustration Issue Month Year
Schéma Issue Month Year
200041/3 4 5 2004

Item Article	Qua Qua	Art.No Réf. article	Description	Description	Info Info	Notes Remarques
1	1	487 2400-60	Beam	Poutre	3	
2	1	487 0289-00	Cable glands	Support de câble	3	M16
3	1	487 0289-02	Cable glands	Support de câble	3	M25
4	1	487 0289-05	Cable glands	Support de câble	3	M63
5	1	487 0289-13	Lock-nut	Contre-écrou	3	M63
6	1	487 0289-10	Lock-nut	Contre-écrou	3	M25
7	1	487 0289-08	Lock-nut	Contre-écrou	3	M16
* 8	1	487 0289-38	Relay	Relais	1,2	Indicating lamp
* 8	2	487 0289-38	Relay	Relais	1,2	Frequency
* 9	7	487 0191-23	Spacer element	Pièce écartement	3	
* 10	1	487 1976-98	Printed circuit board	Carte de circuit imprimé	1,2	
* 10	1	487 1935-06	Printed circuit board	Carte de circuit imprimé	1,2	OPL USA
* 11	1	487 0199-01	Cable set	Ensemble de câbles	3	Standard
* 11	1	487 0199-08	Cable set	Ensemble de câbles	3	Frequency
* 11	1	487 0199-21	Cable set	Ensemble de câbles	3	Emergency stop/door control
* 12	1	487 0199-03	Cable set	Ensemble de câbles	3	Drumotor + frequency
* 12	1	487 0199-15	Cable set	Ensemble de câbles	3	P4-P12B-P18
* 12	1	487 0199-32	Cable set	Ensemble de câbles	3	EI, P10
* 13	1	487 0199-04	Cable set	Ensemble de câbles	3	Switch
* 13	1	487 0199-06	Cable set	Ensemble de câbles	3	Drumotor + frequency
* 13	1	487 0199-29	Cable set	Ensemble de câbles	3	Non heated
* 14	1	487 2217-27	Terminal block	Borne de raccordement	3	Ext.control
* 15	1	487 2217-27	Terminal block	Borne de raccordement	3	Non heated
* 16	1	487 1535-65	Catch	Blocage	1,2	-0304/00000017 - 20900/00000017 USA 0312/00000106- 20900/00000106- USA
* 17	3	438 9636-11	Relay	Relais	1,2	120V 1AC/208-240V 1AC
* 18	1	487 2217-32	Switch	Commutateur	1,2	400-480V 60kW
* 18	1	487 0289-27	Switch	Commutateur	1,2	400-480V 72kW
* 19	1	487 0199-02	Cable set	Ensemble de câbles	3	Motor
* 19	1	487 0199-05	Cable set	Ensemble de câbles	3	Blower motor + frequency
* 19	1	487 0199-06	Cable set	Ensemble de câbles	3	Drum motor
* 20	2	762 1191-10	Cable gland	Passe-fil	3	Ø22
* 21	1	762 1137-10	Cable gland	Passe-fil	3	Ø18
* 22	1	487 0289-23	Ground terminal	Borne de terre	3	
* 23	1	487 1723-95	Cable gland	Passe-fil	3	Ø50
* 24	3	487 2217-24	Terminal block	Borne de raccordement	3	
* 25	3	487 0289-43	Fuse	Fusible	1,2	16A
* 25	3	487 0289-44	Fuse	Fusible	1,2	20A
* 25	3	487 0289-79	Fuse	Fusible	1,2	15A USA
* 26	3	487 0289-42	Fuse holder	Porte-fusible	3	
* 27	2	487 1384-04	End stop	Butée	3	
* 28	1	487 0289-38	Relay	Relais	1,2	
* 29	3	487 0289-85	Clamp	Archet	3	
* 30	3	487 0289-81	Relay socket	Douille	3	
* 31	1	487 1535-79	Capacitor	Condensateur	1,2	
* 32	1	487 2405-44	Bracket	Support	3	Capacitor
* 33	1	487 0289-36	Rail	Rail	3	L=235 400-480V 60kW
* 33	1	487 0289-34	Rail	Rail	3	L=153 400-480V 72kW
* 34	1	487 2405-68	Bracket	Console	3	400-480V 60kW
* 34	1	487 2405-70	Bracket	Console	3	400-480V 72kW
* 35	RQ	487 0289-26	Thermal overload relay	Protection moteur relais	1,2	200-240V 50Hz
* 35	RQ	487 0289-53	Thermal overload relay	Protection moteur relais	1,2	200-240V 60Hz
* 35	RQ	487 0289-25	Thermal overload relay	Protection moteur relais	1,2	400-480V 50/60Hz
* 36	1	487 0289-47	Transformer	Transformateur	1,2	200-240V
* 36	1	487 0289-46	Transformer	Transformateur	1,2	400-480V
* 37	1	487 2405-69	Bracket	Support	3	
* 38	1	487 2400-59	Connection plate	Plaque de connexion	3	

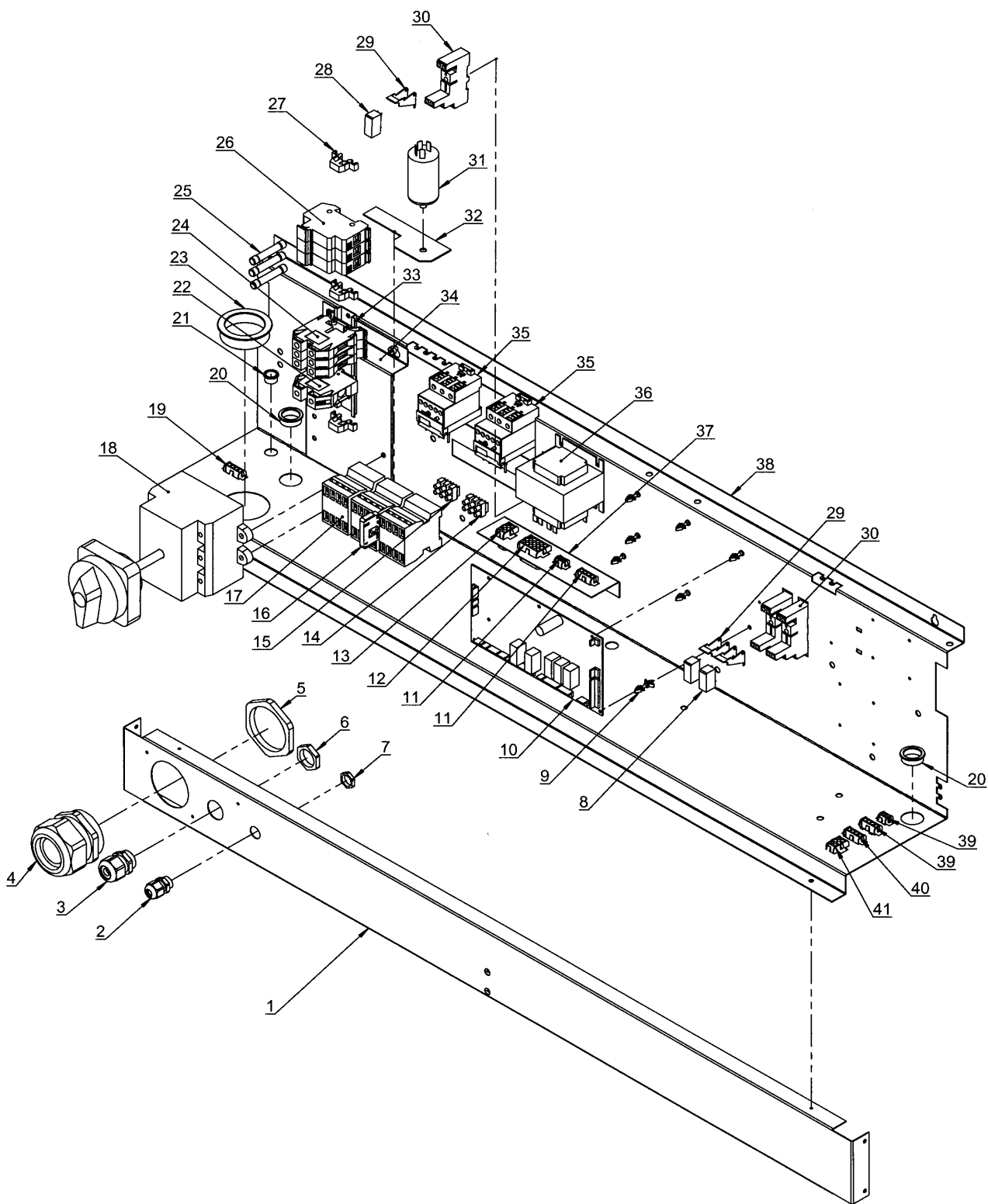

Issue	Month	Year
03	05	04

T3900,TD100

Connection unit, el

Connexion, électrique

Illustration Issue Month Year
Schéma Issue Month Year
200041/3 4 5 2004

Item Article	Qua Qua	Art.No Réf. article	Description	Description	Info Info	Notes Remarques
* 39	1	487 0199-05	Cable set	Ensemble de câbles	3	Blower motor + frequency
* 40	1	487 0199-02	Cable set	Ensemble de câbles	3	Motor
*	1	487 0199-05	Cable set	Ensemble de câbles	3	Blower motor + frequency
*	1	487 0199-06	Cable set	Ensemble de câbles	3	Drum motor
* 41	1	487 0199-03	Cable set	Ensemble de câbles	3	Blower motor + frequency
*	1	487 0199-15	Cable set	Ensemble de câbles	3	P4-P12B-P18
*	1	487 0199-32	Cable set	Ensemble de câbles	3	EI, P10

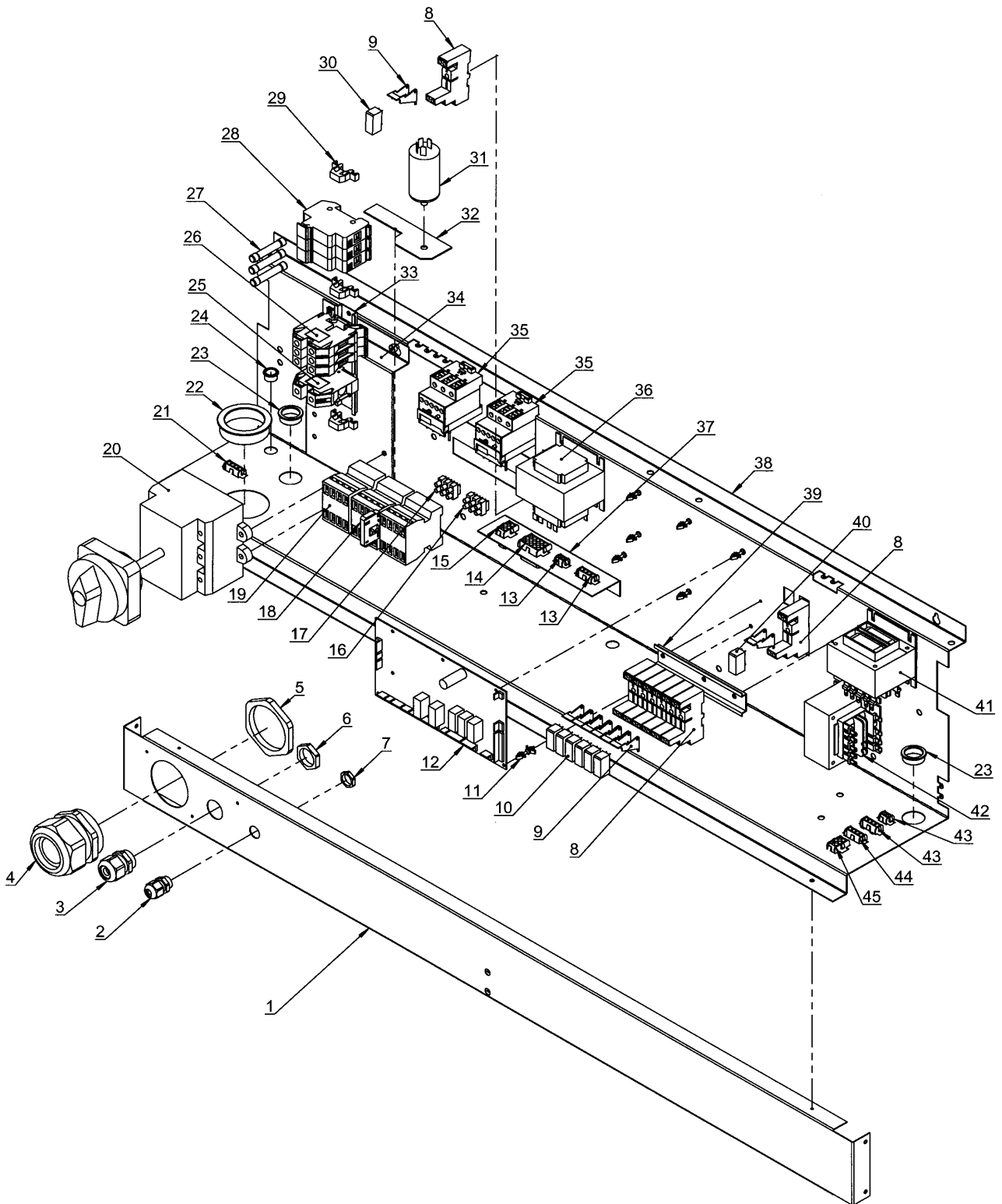

Issue	Month	Year
01	05	04

T3900,TD100

Connection unit - Sliding Door + Tilt, el

Connexion - Sliding Door + Inclinaison, électrique

Illustration Issue Month Year
Schéma Issue Month Year
200165/1 1 5 2004

Item Article	Qua Qua	Art.No Réf. article	Description	Description	Info Info	Notes Remarques
* 1	1	487 2400-60	Beam	Poutre	3	
* 2	1	487 0289-00	Cable glands	Support de câble	3	M16
* 3	1	487 0289-02	Cable glands	Support de câble	3	M25
* 4	1	487 0289-05	Cable glands	Support de câble	3	M63
* 5	1	487 0289-13	Lock-nut	Contre-écrou	3	M63
* 6	1	487 0289-10	Lock-nut	Contre-écrou	3	M25
* 7	1	487 0289-08	Lock-nut	Contre-écrou	3	M16
* 8	8	487 0289-81	Relay socket	Douille	3	
* 9	8	487 0289-85	Clamp	Archet	3	
* 10	6	487 0274-22	Relay	Relais	1,2	Sliding Door + Tilt
* 11	7	487 0191-23	Spacer element	Pièce écartement	3	
* 12	1	487 1976-98	Printed circuit board	Carte de circuit imprimé	1,2	
*	1	487 1935-06	Printed circuit board	Carte de circuit imprimé	1,2	OPL USA
* 13	1	487 0199-21	Cable set	Ensemble de câbles	3	Emergency stop/door control
*	1	487 0199-25	Cable set	Ensemble de câbles	3	Sliding Door, left-hinged
*	1	487 0199-26	Cable set	Ensemble de câbles	3	Sliding Door + Tilt, left-hinged
*	1	487 0199-27	Cable set	Ensemble de câbles	3	Sliding Door, right-hinged
*	1	487 0199-28	Cable set	Ensemble de câbles	3	Sliding Door + Tilt, right-hinged
* 14	1	487 0199-03	Cable set	Ensemble de câbles	3	Drumotor + frequency
*	1	487 0199-15	Cable set	Ensemble de câbles	3	P4-P12B-P18
*	1	487 0199-32	Cable set	Ensemble de câbles	3	EI, P10
* 15	1	487 0199-04	Cable set	Ensemble de câbles	3	Switch
*	1	487 0199-06	Cable set	Ensemble de câbles	3	Drumotor + frequency
*	1	487 0199-29	Cable set	Ensemble de câbles	3	Non heated
* 16	1	487 2217-27	Terminal block	Borne de raccordement	3	Ext.control
* 17	1	487 2217-27	Terminal block	Borne de raccordement	3	Non heated
* 18	1	487 1535-65	Catch	Blocage	1,2	
* 19	3	438 9636-11	Relay	Relais	1,2	120V 1AC/208-240V 1AC
* 20	1	487 2217-32	Switch	Commutateur	1,2	400-480V 60kW
*	1	487 0289-27	Switch	Commutateur	1,2	400-480V 72kW
* 21	1	487 0199-02	Cable set	Ensemble de câbles	3	Motor
*	1	487 0199-05	Cable set	Ensemble de câbles	3	Blower motor + frequency
*	1	487 0199-06	Cable set	Ensemble de câbles	3	Drum motor
* 22	1	487 1723-95	Cable gland	Passe-fil	3	Ø50
* 23	2	762 1191-10	Cable gland	Passe-fil	3	Ø22
* 24	1	762 1137-10	Cable gland	Passe-fil	3	Ø18
* 25	1	487 0289-23	Ground terminal	Borne de terre	3	
* 26	3	487 2217-24	Terminal block	Borne de raccordement	3	
* 27	3	487 0289-43	Fuse	Fusible	1,2	16A
*	3	487 0289-44	Fuse	Fusible	1,2	20A
*	3	487 0289-79	Fuse	Fusible	1,2	15A USA
* 28	3	487 0289-42	Fuse holder	Porte-fusible	3	
* 29	3	487 1384-04	End stop	Butée	3	
* 30	1	487 0289-38	Relay	Relais	1,2	
* 31	1	487 1535-79	Capacitor	Condensateur	1,2	
* 32	1	487 2405-44	Bracket	Support	3	Capacitor
* 33	1	487 0289-36	Rail	Rail	3	L=235 400-480V 60kW
*	1	487 0289-34	Rail	Rail	3	L=153 400-480V 72kW
* 34	1	487 2405-68	Bracket	Console	3	400-480V 60kW
*	1	487 2405-70	Bracket	Console	3	400-480V 72kW
* 35	RQ	487 0289-26	Thermal overload relay	Protection moteur relais	1,2	200-240V 50Hz
*	RQ	487 0289-53	Thermal overload relay	Protection moteur relais	1,2	200-240V 60Hz
*	RQ	487 0289-25	Thermal overload relay	Protection moteur relais	1,2	400-480V 50/60Hz
* 36	1	487 0289-47	Transformer	Transformateur	1,2	200-240V
*	1	487 0289-46	Transformer	Transformateur	1,2	400-480V
* 37	1	487 2405-69	Bracket	Support	3	
* 38	1	487 2400-59	Connection plate	Plaque de connexion	3	
* 39	1	487 0289-34	Rail	Rail	3	L=153 Sliding Door + Tilt
* 40	1	487 0274-22	Relay	Relais	3	Frequency

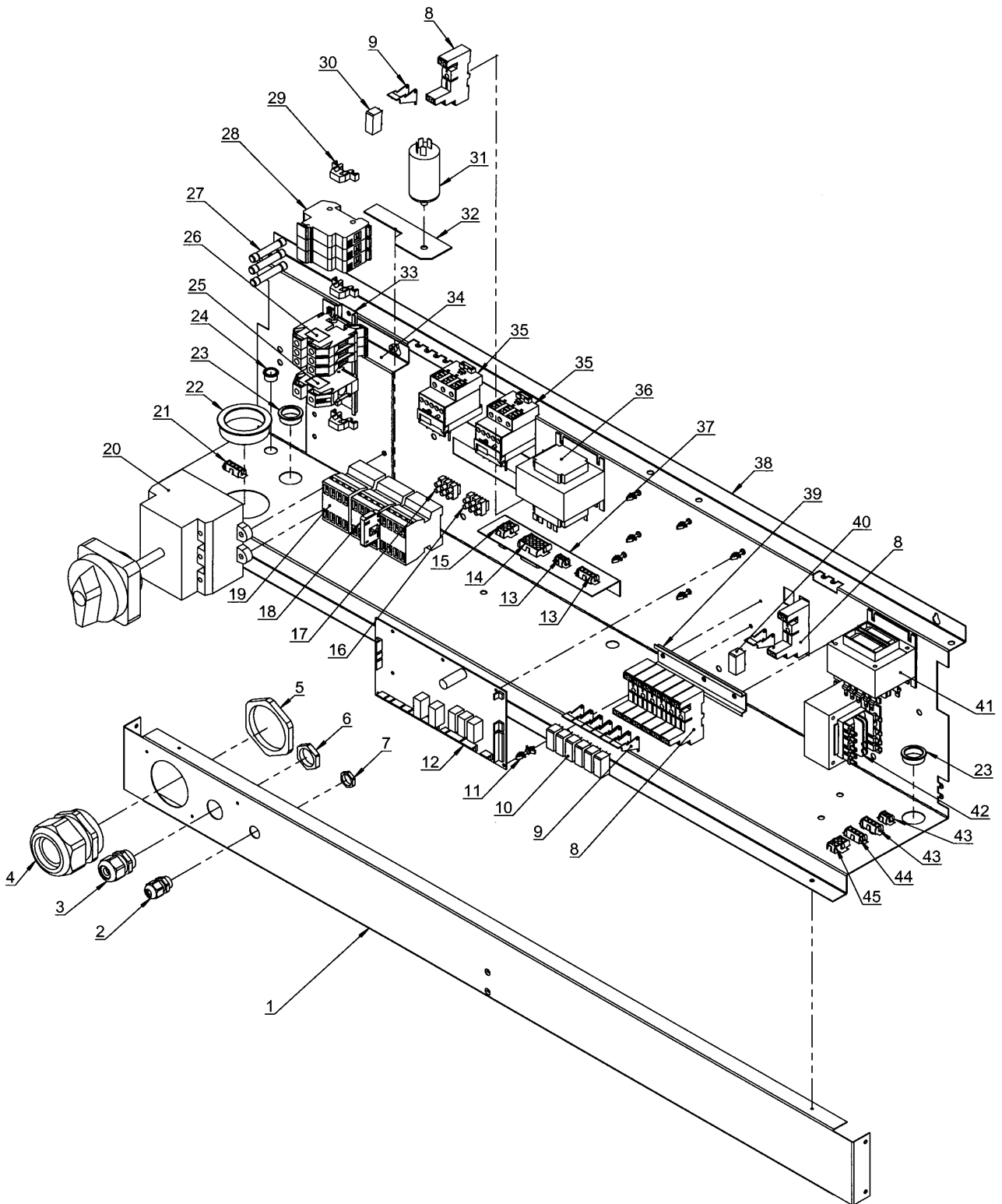

Issue	Month	Year
01	05	04

T3900,TD100

Connection unit - Sliding Door + Tilt, el

Connexion - Sliding Door + Inclinaison, électrique

Illustration	Issue	Month	Year
Schéma	Issue	Month	Year
200165/1	1	5	2004

Item Article	Qua Qua	Art.No Réf. article	Description	Description	Info Info	Notes Remarques
* 41	1	487 0274-13	Transformer	Transformateur	1,2	200-240V 60Hz Sliding Door + Tilt
* 42	2	487 0274-12	Transformer	Transformateur	1,2	230-240V/400-480V 50Hz Sliding Door + Tilt
* 43	1	487 0199-05	Cable set	Ensemble de câbles	3	Blower motor + frequency
* 44	1	487 0199-02	Cable set	Ensemble de câbles	3	Motor
*	1	487 0199-05	Cable set	Ensemble de câbles	3	Blower motor + frequency
*	1	487 0199-06	Cable set	Ensemble de câbles	3	Drum motor
* 45	1	487 0199-03	Cable set	Ensemble de câbles	3	Drumotor + frequency
*	1	487 0199-15	Cable set	Ensemble de câbles	3	P4-P12B-P18
*	1	487 0199-32	Cable set	Ensemble de câbles	3	EI, P10

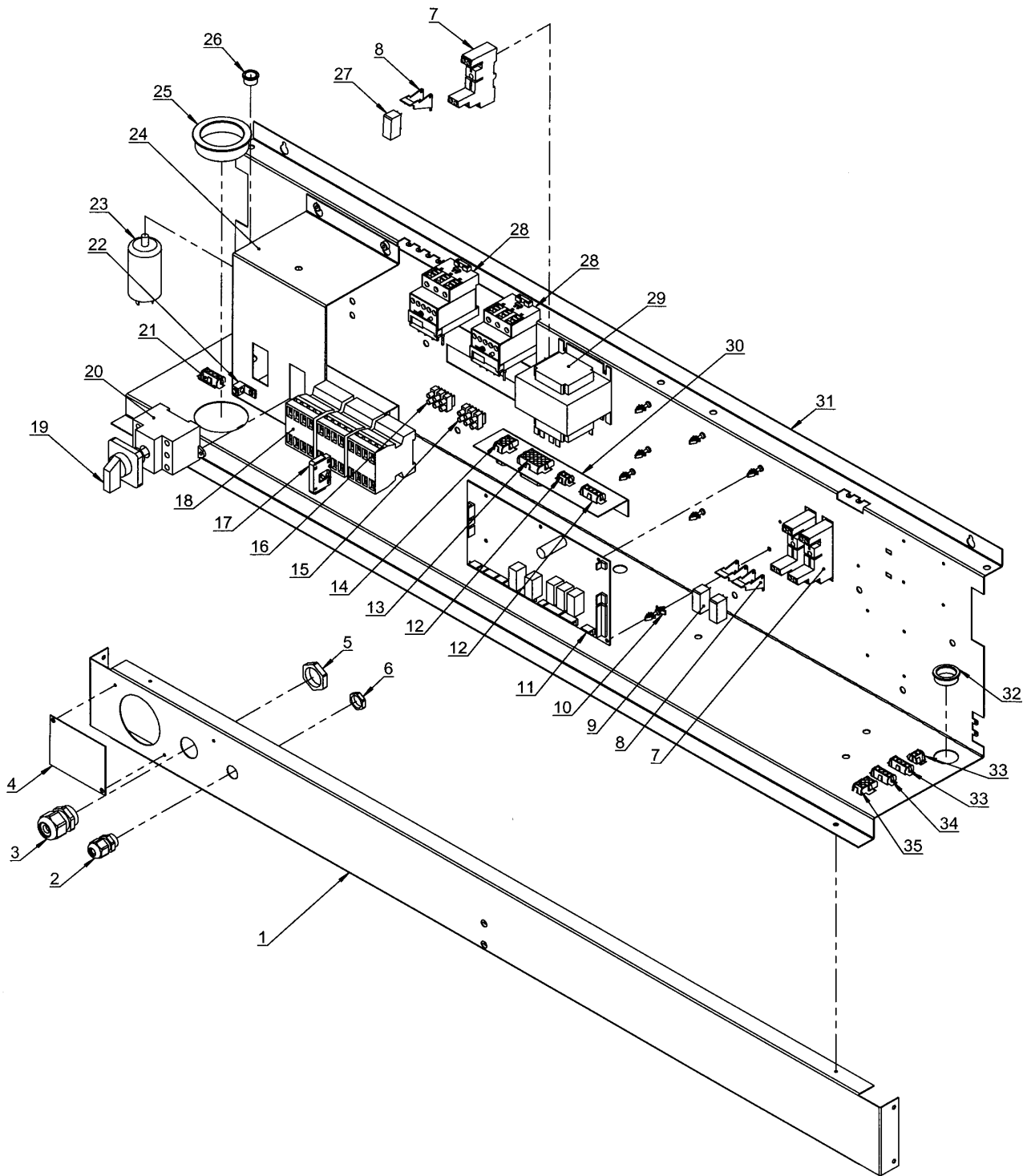

Issue	Month	Year
03	05	04

T3900,TD100

Connection unit, gas, steam

Connexion, gaz, vapeur

Illustration Issue Month Year
Schéma Issue Month Year
200042/3 4 5 2004

Item Article	Qua Qua	Art.No Réf. article	Description	Description	Info Info	Notes Remarques
1	1	487 2400-60	Beam	Poutre	3	
2	1	487 0289-00	Cable glands	Support de câble	3	M16
3	1	487 0289-02	Cable glands	Support de câble	3	M25
4	1	487 2405-33	Cover plate	Plaque recouvrement	3	
5	1	487 0289-10	Lock-nut	Contre-écrou	3	M25
6	1	487 0289-08	Lock-nut	Contre-écrou	3	M16
* 7	3	487 0289-81	Relay socket	Douille	3	
* 8	3	487 0289-85	Clamp	Archet	3	
* 9	1	487 0289-38	Relay	Relais	1,2	Indicating lamp
*	2	487 0289-38	Relay	Relais	1,2	Frequency
* 10	7	487 0191-23	Spacer element	Pièce écartement	3	
* 11	1	487 1976-98	Printed circuit board	Carte de circuit imprimé	1,2	
*	1	487 1935-06	Printed circuit board	Carte de circuit imprimé	1,2	OPL USA
* 12	1	487 0199-01	Cable set	Ensemble de câbles	3	Standard
*	1	487 0199-08	Cable set	Ensemble de câbles	3	Frequency
*	1	487 0199-21	Cable set	Ensemble de câbles	3	Emergency stop/door control
* 13	1	487 0199-03	Cable set	Ensemble de câbles	3	Drumotor + frequency
*	1	487 0199-15	Cable set	Ensemble de câbles	3	P4-P12B-P18
*	1	487 0199-30	Cable set	Ensemble de câbles	3	Gas
*	1	487 0199-31	Cable set	Ensemble de câbles	3	Steam
* 14	1	487 0199-04	Cable set	Ensemble de câbles	3	Switch
*	1	487 0199-06	Cable set	Ensemble de câbles	3	Drumotor + frequency
*	1	487 0199-29	Cable set	Ensemble de câbles	3	Non heated
* 15	1	487 2217-27	Terminal block	Borne de raccordement	3	Ext.control
* 16	1	487 2217-27	Terminal block	Borne de raccordement	3	Non heated
* 17	1	487 1535-65	Catch	Blocage	1,2	-0304/00000017 - 20900/00000017 USA 0312/00000106- 20900/00000106- USA
* 18	3	438 9636-11	Relay	Relais	1,2	120V 1AC/208-240V 1AC
* 19	1	487 2217-33	Turning device	Dispositif	1,2	
* 20	1	487 2217-30	Switch	Commutateur	1,2	
* 21	1	487 0199-02	Cable set	Ensemble de câbles	3	Motor
*	1	487 0199-05	Cable set	Ensemble de câbles	3	Blower motor + frequency
*	1	487 0199-06	Cable set	Ensemble de câbles	3	Drum motor
* 22	1	487 0289-16	Ground terminal	Borne de terre	3	
* 23	1	487 1535-79	Capacitor	Condensateur	1,2	
* 24	1	487 2400-65	Bracket	Console	3	
* 25	1	487 1723-95	Cable gland	Passe-fil	3	Ø50
* 26	1	762 1137-10	Cable gland	Passe-fil	3	Ø18
* 27	1	487 0289-38	Relay	Relais	1,2	
* 28	RQ	487 0289-26	Thermal overload relay	Protection moteur relais	1,2	200-240V 50Hz
*	RQ	487 0289-53	Thermal overload relay	Protection moteur relais	1,2	200-240V 60Hz
*	RQ	487 0289-25	Thermal overload relay	Protection moteur relais	1,2	400-480V 50/60Hz
* 29	1	487 0289-47	Transformer	Transformateur	1,2	200-240V
*	1	487 0289-46	Transformer	Transformateur	1,2	400-480V
* 30	1	487 2405-69	Bracket	Support	3	
* 31	1	487 2400-59	Connection plate	Plaque de connexion	3	
* 32	1	762 1191-10	Cable gland	Passe-fil	3	Ø22
* 33	1	487 0199-05	Cable set	Ensemble de câbles	3	Blower motor + frequency
* 34	1	487 0199-02	Cable set	Ensemble de câbles	3	Motor
*	1	487 0199-05	Cable set	Ensemble de câbles	3	Blower motor + frequency
*	1	487 0199-06	Cable set	Ensemble de câbles	3	Drum motor
* 35	1	487 0199-03	Cable set	Ensemble de câbles	3	Drumotor + frequency
*	1	487 0199-15	Cable set	Ensemble de câbles	3	P4-P12B-P18
*	1	487 0199-30	Cable set	Ensemble de câbles	3	Gas
*	1	487 0199-31	Cable set	Ensemble de câbles	3	Steam

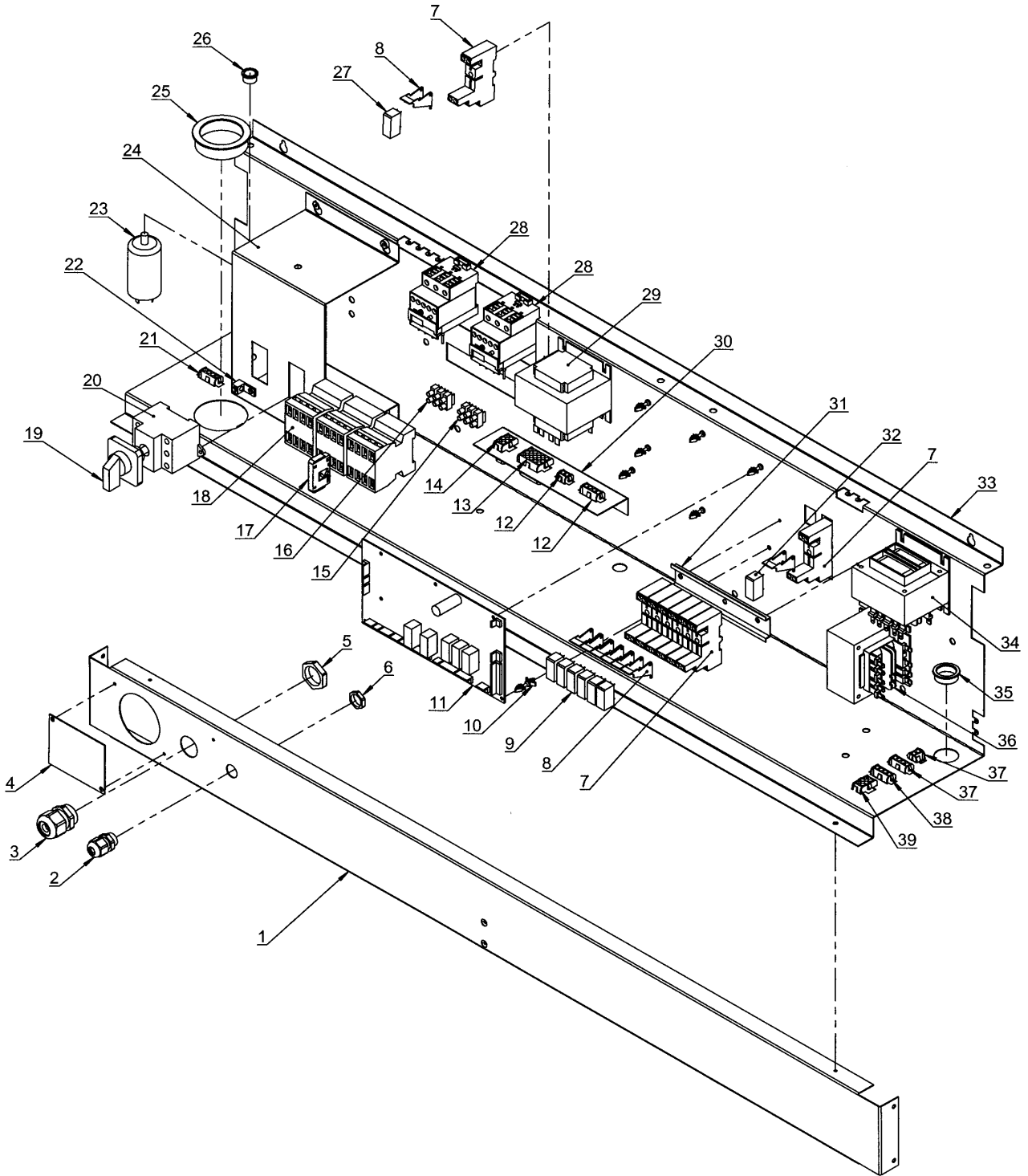

Issue	Month	Year
01	05	04

T3900,TD100

Connection unit - Sliding Door + Tilt, gas + steam

Connexion - Sliding Door + Inclinaison, gaz + vapeur

Illustration Issue Month Year
Schéma Issue Month Year
200166/1 1 5 2004

Item Article	Qua Qua	Art.No Réf. article	Description	Description	Info Info	Notes Remarques
* 1	1	487 2400-60	Beam	Poutre	3	
* 2	1	487 0289-00	Cable glands	Support de câble	3	M16
* 3	1	487 0289-02	Cable glands	Support de câble	3	M25
* 4	1	487 2405-33	Cover plate	Plaque recouvrement	3	
* 5	1	487 0289-10	Lock-nut	Contre-écrou	3	M25
* 6	1	487 0289-08	Lock-nut	Contre-écrou	3	M16
* 7	8	487 0289-81	Relay socket	Douille	3	
* 8	8	487 0289-85	Clamp	Archet	3	
* 9	5	487 0274-22	Relay	Relais	1,2	Sliding Door + Tilt
* 10	7	487 0191-23	Spacer element	Pièce écartement	3	
* 11	1	487 1976-98	Printed circuit board	Carte de circuit imprimé	1,2	
* 11	1	487 1935-06	Printed circuit board	Carte de circuit imprimé	1,2	OPL USA
* 12	1	487 0199-01	Cable set	Ensemble de câbles	3	Standard
*	1	487 0199-08	Cable set	Ensemble de câbles	3	Frequency
*	1	487 0199-21	Cable set	Ensemble de câbles	3	Emergency stop/door control
* 13	1	487 0199-03	Cable set	Ensemble de câbles	3	Drumotor + frequency
*	1	487 0199-15	Cable set	Ensemble de câbles	3	P4-P12B-P18
*	1	487 0199-30	Cable set	Ensemble de câbles	3	Gas
*	1	487 0199-31	Cable set	Ensemble de câbles	3	Steam
* 14	1	487 0199-04	Cable set	Ensemble de câbles	3	Switch
*	1	487 0199-06	Cable set	Ensemble de câbles	3	Drumotor + frequency
*	1	487 0199-29	Cable set	Ensemble de câbles	3	Non heated
* 15	1	487 2217-27	Terminal block	Borne de raccordement	3	Ext.control
* 16	1	487 2217-27	Terminal block	Borne de raccordement	3	Non heated
* 17	1	487 1535-65	Catch	Blocage	1,2	
* 18	3	438 9636-11	Relay	Relais	1,2	120V 1AC/208-240V 1AC
* 19	1	487 2217-33	Turning device	Dispositif	1,2	
* 20	1	487 2217-30	Switch	Commutateur	1,2	
* 21	1	487 0199-02	Cable set	Ensemble de câbles	3	Motor
*	1	487 0199-05	Cable set	Ensemble de câbles	3	Blower motor + frequency
*	1	487 0199-06	Cable set	Ensemble de câbles	3	Drum motor
* 22	1	487 0289-16	Ground terminal	Borne de terre	3	
* 23	1	487 1535-79	Capacitor	Condensateur	1,2	
* 24	1	487 2400-65	Bracket	Console	3	
* 25	1	487 1723-95	Cable gland	Passe-fil	3	Ø50
* 26	1	762 1137-10	Cable gland	Passe-fil	3	Ø18
* 27	1	487 0289-38	Relay	Relais	1,2	
* 28	RQ	487 0289-26	Thermal overload relay	Protection moteur relais	1,2	200-240V 50Hz
*	RQ	487 0289-53	Thermal overload relay	Protection moteur relais	1,2	200-240V 60Hz
*	RQ	487 0289-25	Thermal overload relay	Protection moteur relais	1,2	400-480V 50/60Hz
* 29	1	487 0289-47	Transformer	Transformateur	1,2	200-240V
*	1	487 0289-46	Transformer	Transformateur	1,2	400-480V
* 30	1	487 2405-69	Bracket	Support	3	
* 31	1	487 0289-34	Rail	Rail	3	L=153 Sliding Door + Tilt
* 32	1	487 0274-22	Relay	Relais	1,2	Frequency
* 33	1	487 2400-59	Connection plate	Plaque de connexion	3	
* 34	1	487 0274-13	Transformer	Transformateur	1,2	200-240V 60Hz Sliding Door + Tilt
* 35	1	762 1191-10	Cable gland	Passe-fil	3	Ø22
* 36	2	487 0274-12	Transformer	Transformateur	1,2	230-240V/400-480V 50Hz Sliding Door + Tilt
* 37	1	487 0199-05	Cable set	Ensemble de câbles	3	Blower motor + frequency
* 38	1	487 0199-02	Cable set	Ensemble de câbles	3	Motor
*	1	487 0199-05	Cable set	Ensemble de câbles	3	Blower motor + frequency
*	1	487 0199-06	Cable set	Ensemble de câbles	3	Drum motor
* 39	1	487 0199-03	Cable set	Ensemble de câbles	3	Drumotor + frequency
*	1	487 0199-05	Cable set	Ensemble de câbles	3	Blower motor + frequency
*	1	487 0199-06	Cable set	Ensemble de câbles	3	Drum motor

Numerical index/Numerical index

Art.No/Réf. article	Page/Page	Art.No/Réf. article	Page/Page	Art.No/Réf. article	Page/Page	Art.No/Réf. article	Page/Page
432 2620-06	7	487 0199-02*	61	487 0274-13*	63	487 0289-53*	61
432 2620-07	7	487 0199-02*	63	487 0274-22*	57	487 0289-53*	63
432 2620-08	7	487 0199-03*	53	487 0274-22*	63	487 0289-57	37
432 2620-09	7	487 0199-03*	55	487 0289-00	53	487 0289-60	37
438 9636-11*	53	487 0199-03*	57	487 0289-00*	57	487 0289-63	37
438 9636-11*	57	487 0199-03*	59	487 0289-00	61	487 0289-64	13
438 9636-11*	61	487 0199-03*	61	487 0289-00*	63	487 0289-64	15
438 9636-11*	63	487 0199-03*	63	487 0289-02	53	487 0289-64	17
438 9637-31	43	487 0199-04*	53	487 0289-02*	57	487 0289-65	13
471 1765-33	27	487 0199-04*	57	487 0289-02	61	487 0289-65	15
471 1765-33	29	487 0199-04*	61	487 0289-02*	63	487 0289-65	17
471 1765-34	27	487 0199-04*	63	487 0289-05	53	487 0289-66	13
471 1765-34	29	487 0199-05*	53	487 0289-05*	57	487 0289-66	15
471 1765-35	31	487 0199-05*	55	487 0289-08	53	487 0289-66	17
471 1765-36	31	487 0199-05*	57	487 0289-08*	57	487 0289-69	7
471 2068-48	7	487 0199-05*	59	487 0289-08	61	487 0289-69	15
471 2068-48	25	487 0199-05*	61	487 0289-08*	63	487 0289-69*	17
471 2068-48	27	487 0199-05*	63	487 0289-10	53	487 0289-72*	17
471 2068-48	29	487 0199-06*	53	487 0289-10*	57	487 0289-73*	17
471 2068-48	35	487 0199-06*	55	487 0289-10	61	487 0289-74*	17
471 2068-48	41	487 0199-06*	57	487 0289-10*	63	487 0289-75	7
471 4672-16	7	487 0199-06*	59	487 0289-13	53	487 0289-75	15
471 4672-16*	11	487 0199-06*	61	487 0289-13*	57	487 0289-75	17
471 7903-03	27	487 0199-06*	63	487 0289-16*	61	487 0289-76	7
471 7903-03	29	487 0199-08*	53	487 0289-16*	63	487 0289-76	15
471 8400-06	45	487 0199-08*	61	487 0289-17	43	487 0289-76*	17
471 8502-18	27	487 0199-08*	63	487 0289-23	43	487 0289-79*	53
471 8502-18	29	487 0199-10*	33	487 0289-23*	53	487 0289-79*	57
471 9628-32	15	487 0199-11*	33	487 0289-23*	57	487 0289-81*	53
471 9628-32	17	487 0199-15*	53	487 0289-25*	53	487 0289-81*	57
471 9628-70	15	487 0199-15*	55	487 0289-25*	57	487 0289-81*	61
471 9628-70*	17	487 0199-15*	57	487 0289-25*	61	487 0289-81*	63
471 9628-71*	17	487 0199-15*	59	487 0289-25*	63	487 0289-85*	53
471 9628-75	7	487 0199-15*	61	487 0289-26*	53	487 0289-85*	57
471 9628-75	15	487 0199-15*	63	487 0289-26*	57	487 0289-85*	61
471 9628-75*	17	487 0199-16	35	487 0289-26*	61	487 0289-85*	63
471 9853-49	45	487 0199-21*	53	487 0289-26*	63	487 0289-87	39
471 9853-68	45	487 0199-21*	57	487 0289-27*	53	487 0289-89	33
471 9853-76	45	487 0199-21*	61	487 0289-27*	57	487 0289-99	39
471 9853-84	45	487 0199-21*	63	487 0289-33	33	487 0324-71	47
472 7307-01	27	487 0199-25*	57	487 0289-34*	53	487 1363-01	27
472 7307-01	29	487 0199-26*	57	487 0289-34*	57	487 1363-01	29
472 7308-01	27	487 0199-27*	57	487 0289-34*	63	487 1384-04	43
472 7308-01	29	487 0199-28*	57	487 0289-35	43	487 1384-04*	53
472 7414-01*	9	487 0199-29*	53	487 0289-36*	53	487 1384-04*	57
472 7414-01	41	487 0199-29*	57	487 0289-36*	57	487 1437-25	45
472 8004-01	27	487 0199-29*	61	487 0289-38*	53	487 1438-21	45
472 8004-01	29	487 0199-29*	63	487 0289-38*	57	487 1438-25	45
487 0068-20	45	487 0199-30*	61	487 0289-38*	61	487 1510-88	25
487 0068-27	45	487 0199-30*	63	487 0289-38*	63	487 1531-61	43
487 0068-28	45	487 0199-31*	61	487 0289-42*	53	487 1531-62	43
487 0098-12	27	487 0199-31*	63	487 0289-42*	57	487 1531-63	43
487 0098-12	29	487 0199-32*	53	487 0289-43*	53	487 1531-68	43
487 0101-30	41	487 0199-32*	55	487 0289-43*	57	487 1531-73	43
487 0187-28	19	487 0199-32*	57	487 0289-44*	53	487 1531-74	43
487 0191-23*	53	487 0199-32*	59	487 0289-44*	57	487 1531-75	43
487 0191-23*	57	487 0199-42	37	487 0289-46*	53	487 1531-76	43
487 0191-23*	61	487 0199-49	31	487 0289-46*	57	487 1533-95	45
487 0191-23*	63	487 0199-51	13	487 0289-46*	61	487 1533-96	45
487 0199-01*	53	487 0199-53	15	487 0289-46*	63	487 1533-97	45
487 0199-01*	61	487 0199-53	17	487 0289-47*	53	487 1535-04	41
487 0199-01*	63	487 0199-54	15	487 0289-47*	57	487 1535-04	43
487 0199-02*	53	487 0199-54	17	487 0289-47*	61	487 1535-04	45
487 0199-02*	55	487 0274-12*	59	487 0289-47*	63	487 1535-21	13
487 0199-02*	57	487 0274-12*	63	487 0289-53*	53	487 1535-21*	15
487 0199-02*	59	487 0274-13*	59	487 0289-53*	57	487 1535-21*	17

Numerical index/Numerical index

Art.No/Réf. article	Page/Page	Art.No/Réf. article	Page/Page	Art.No/Réf. article	Page/Page	Art.No/Réf. article	Page/Page
487 1535-65*	53	487 1820-35	31	487 2217-33*	61	487 2400-58	29
487 1535-65*	57	487 1831-00	31	487 2217-33*	63	487 2400-59*	53
487 1535-65*	61	487 1875-30*	23	487 2226-45	43	487 2400-59*	57
487 1535-65*	63	487 1897-05	27	487 2226-45	45	487 2400-59*	61
487 1535-79*	53	487 1897-05	29	487 2226-45	49	487 2400-59*	63
487 1535-79*	57	487 1898-10	7	487 2226-45	51	487 2400-60	53
487 1535-79*	61	487 1898-10	25	487 2226-87	13	487 2400-60*	57
487 1535-79*	63	487 1898-10	35	487 2226-87	15	487 2400-60	61
487 1626-04	7	487 1898-10	41	487 2226-87	17	487 2400-60*	63
487 1654-06	33	487 1920-05	25	487 2228-23	11	487 2400-61	7
487 1694-18	37	487 1924-03	13	487 2228-26*	11	487 2400-63	33
487 1694-56	27	487 1924-03	15	487 2228-35	11	487 2400-64	33
487 1694-58	41	487 1924-03	17	487 2255-15	43	487 2400-65*	61
487 1694-78	27	487 1934-20	13	487 2255-28	27	487 2400-65*	63
487 1694-78	29	487 1934-20*	15	487 2255-28	29	487 2400-66	33
487 1695-48	33	487 1934-20	17	487 2256-07	7	487 2400-68	33
487 1695-49	33	487 1934-50	45	487 2256-07	41	487 2400-69	41
487 1697-08	43	487 1934-71	41	487 2317-84	41	487 2400-70	41
487 1697-08	45	487 1934-71	47	487 2317-84	47	487 2400-72	41
487 1714-70	13	487 1935-06*	53	487 2327-95	31	487 2400-74	33
487 1714-70*	15	487 1935-06*	57	487 2328-85	47	487 2400-75	33
487 1714-70*	17	487 1935-06*	61	487 2330-10	47	487 2400-76	33
487 1714-71	23	487 1935-06*	63	487 2330-11	47	487 2400-79	41
487 1714-72	23	487 1935-13	37	487 2330-13	47	487 2400-80	41
487 1714-73	23	487 1935-14	37	487 2330-14	47	487 2400-81	33
487 1714-74	23	487 1935-15	13	487 2330-15	47	487 2400-82	33
487 1714-75	23	487 1935-16*	33	487 2330-16	47	487 2400-83	33
487 1714-76*	23	487 1935-17*	33	487 2336-60*	9	487 2400-84	33
487 1714-78	7	487 1935-19	7	487 2336-61*	7	487 2400-89	27
487 1714-78	13	487 1935-20	7	487 2359-70	7	487 2400-89	29
487 1714-79	7	487 1935-21	7	487 2359-73	7	487 2400-89	31
487 1714-80	7	487 1935-22	7	487 2359-95	27	487 2400-90	45
487 1714-81	7	487 1935-23	7	487 2359-95	29	487 2400-95	45
487 1714-82	7	487 1935-24	7	487 2400-00	33	487 2400-97	45
487 1714-83	7	487 1935-25	7	487 2400-08	33	487 2400-98	33
487 1714-84	7	487 1935-26	7	487 2400-09	33	487 2401-55	39
487 1714-85	7	487 1935-27	7	487 2400-12	27	487 2405-01	33
487 1714-86	7	487 1935-28	7	487 2400-12	29	487 2405-15	45
487 1714-87	7	487 1935-29	7	487 2400-18	7	487 2405-18	45
487 1714-88	7	487 1935-30	7	487 2400-24	19	487 2405-25	43
487 1714-89	7	487 1935-53	25	487 2400-25	27	487 2405-27	43
487 1714-90	7	487 1935-72	39	487 2400-26	11	487 2405-28	43
487 1714-91	7	487 1935-73*	11	487 2400-26	41	487 2405-32	43
487 1714-92*	9	487 1935-74*	23	487 2400-33	41	487 2405-33	61
487 1714-93	43	487 1969-83	7	487 2400-34	27	487 2405-33*	63
487 1714-94	45	487 1969-88	13	487 2400-35	27	487 2405-37	43
487 1714-95	43	487 1969-88*	15	487 2400-37	33	487 2405-41	41
487 1714-96	49	487 1969-88*	17	487 2400-38	41	487 2405-42	37
487 1714-97	45	487 1974-96*	23	487 2400-39	33	487 2405-43	33
487 1714-97	47	487 1974-96	25	487 2400-40	27	487 2405-44*	53
487 1714-99	7	487 1976-98*	53	487 2400-40	29	487 2405-44*	57
487 1723-95	7	487 1976-98*	57	487 2400-40	31	487 2405-52	27
487 1723-95*	53	487 1976-98*	61	487 2400-40	33	487 2405-52	29
487 1723-95*	57	487 1976-98*	63	487 2400-40	39	487 2405-56	27
487 1723-95*	61	487 2217-24	43	487 2400-43	33	487 2405-56	29
487 1723-95*	63	487 2217-24*	53	487 2400-44	33	487 2405-56	41
487 1756-35	19	487 2217-24*	57	487 2400-45	33	487 2405-57	27
487 1760-31*	9	487 2217-25	43	487 2400-46	27	487 2405-57	29
487 1764-14	45	487 2217-27*	53	487 2400-46	29	487 2405-58	27
487 1781-19	43	487 2217-27*	57	487 2400-46	47	487 2405-58	29
487 1781-22	43	487 2217-27*	61	487 2400-48	33	487 2405-59	27
487 1781-51	49	487 2217-27*	63	487 2400-52	33	487 2405-59	29
487 1813-10	41	487 2217-30*	61	487 2400-55	33	487 2405-62	27
487 1816-56	7	487 2217-30*	63	487 2400-57	27	487 2405-62	29
487 1818-25	19	487 2217-32*	53	487 2400-57	29	487 2405-65	7
487 1820-34	31	487 2217-32*	57	487 2400-58	27	487 2405-65	43

Numerical index/Numerical index

Art.No/Réf. article	Page/Page	Art.No/Réf. article	Page/Page	Art.No/Réf. article	Page/Page	Art.No/Réf. article	Page/Page
487 2405-65	45	487 2411-62	51	487 2426-55*	11	487 2440-40	11
487 2405-65	47	487 2411-63	49	487 2426-56	11	487 2441-05	11
487 2405-65	49	487 2411-63	51	487 2426-60	25	487 2441-40	11
487 2405-66	33	487 2411-64	49	487 2426-62	11	487 2442-05	51
487 2405-68*	53	487 2411-64	51	487 2426-63	11	487 2442-40	51
487 2405-68*	57	487 2411-65	43	487 2426-68	17	487 2443-05	51
487 2405-69*	53	487 2411-65	45	487 2426-69	17	487 2443-40	51
487 2405-69*	57	487 2411-65	51	487 2426-70	15	487 2446-90*	23
487 2405-69*	61	487 2411-67	43	487 2426-71	15	487 2447-61	25
487 2405-69*	63	487 2411-67	45	487 2426-72	17	487 2447-70	11
487 2405-70*	53	487 2411-67	49	487 2426-73	17	487 2447-80*	11
487 2405-70*	57	487 2411-73	43	487 2426-74	15	487 2447-81*	11
487 2405-78	33	487 2411-73	45	487 2426-75	15	487 2448-72	21
487 2405-81	13	487 2411-73	49	487 2426-76*	21	487 2448-76	21
487 2405-82	13	487 2411-80	13	487 2426-79	21	487 2450-05*	23
487 2405-90	49	487 2411-81	13	487 2426-82	11	487 2450-06*	23
487 2405-91	49	487 2412-02	33	487 2426-82	21	487 2450-41*	23
487 2405-96	41	487 2412-12	33	487 2426-84	11	487 2450-55*	23
487 2405-97	41	487 2412-19	33	487 2426-85	21	487 2450-63*	23
487 2406-00	43	487 2414-05	43	487 2426-88*	11	487 2450-77*	23
487 2406-00	45	487 2414-05	45	487 2426-91	11	487 3390-02*	7
487 2406-01	7	487 2414-05	49	487 2426-94	25	487 7056-53	47
487 2406-02	7	487 2414-05	51	487 2426-98	11	487 7057-40	13
487 2406-04	33	487 2414-40	43	487 2426-99	11	487 7057-40*	15
487 2406-05	7	487 2414-40	45	487 2427-04	15	487 7057-40*	17
487 2406-09	13	487 2414-40	49	487 2427-04*	17	724 1228-01	35
487 2408-05	31	487 2414-40	51	487 2427-20*	39	725 2477-51	33
487 2408-20	31	487 2414-55	43	487 2427-21	35	728 5289-00	31
487 2408-21	31	487 2414-55	45	487 2427-22	35	732 2210-01	35
487 2408-33	43	487 2414-55	49	487 2427-23	35	735 3126-00	33
487 2408-33	45	487 2422-72	31	487 2427-24*	15	762 1137-10	49
487 2408-36	45	487 2422-73	31	487 2427-24*	17	762 1137-10*	53
487 2408-38	45	487 2422-75	31	487 2427-25*	39	762 1137-10*	57
487 2408-39	45	487 2422-80	33	487 2427-26*	39	762 1137-10*	61
487 2408-75	47	487 2422-82	29	487 2427-27*	39	762 1137-10*	63
487 2408-82	19	487 2422-83	29	487 2427-44*	15	762 1191-10	7
487 2409-05	7	487 2422-84	29	487 2427-44*	17	762 1191-10*	53
487 2409-13	31	487 2422-85	29	487 2427-46	31	762 1191-10*	57
487 2409-14	31	487 2422-86	29	487 2427-55	25	762 1191-10*	61
487 2409-40	7	487 2422-90	31	487 2427-57	11	762 1191-10*	63
487 2409-55	7	487 2426-00	51	487 2427-62	39	762 7202-57	41
487 2410-15	43	487 2426-01	51	487 2427-69	39	762 7202-57	43
487 2410-15	45	487 2426-02*	11	487 2427-76	39	762 7202-57	45
487 2410-15	49	487 2426-03	35	487 2427-82	39		
487 2410-40	7	487 2426-04*	15	487 2427-83	39		
487 2410-50	43	487 2426-04*	17	487 2427-85*	39		
487 2410-50	45	487 2426-05	39	487 2427-86	39		
487 2410-50	49	487 2426-06	11	487 2427-87	39		
487 2410-55	7	487 2426-07	11	487 2427-90*	39		
487 2410-80	43	487 2426-08*	11	487 2427-91	39		
487 2410-80	45	487 2426-09	11	487 2427-92	39		
487 2410-80	49	487 2426-16	11	487 2427-93	39		
487 2411-05	43	487 2426-17	11	487 2427-96*	39		
487 2411-05	45	487 2426-18	11	487 2427-99	11		
487 2411-05	49	487 2426-20	21	487 2429-55	39		
487 2411-06	43	487 2426-22	21	487 2436-05	39		
487 2411-06	45	487 2426-24	11	487 2436-07	21		
487 2411-06	49	487 2426-31	21	487 2436-09	21		
487 2411-41	43	487 2426-36	21	487 2436-10	11		
487 2411-41	45	487 2426-39	21	487 2436-11	21		
487 2411-41	49	487 2426-48	11	487 2436-55	39		
487 2411-55	43	487 2426-50	21	487 2437-55*	39		
487 2411-55	45	487 2426-51	11	487 2438-55	51		
487 2411-55	49	487 2426-52	11	487 2439-55	21		
487 2411-62	43	487 2426-53	11	487 2439-99	11		
487 2411-62	45	487 2426-54	11	487 2440-05	11		

Numerical index/Numerical index

Art.No/Réf. article Page/Page Art.No/Réf. article Page/Page Art.No/Réf. article Page/Page Art.No/Réf. article Page/Page

--	--	--	--

WASCOMAT

461 Doughty Blvd., Inwood, L.I., N.Y. 11096-0338

Telephone: 516-371-4400

Parts and Service FAX: 516-371-4029

Sales and Administration FAX: 516-371-4204