

WASCOMAT

Spare Parts Catalogue

Catalogue de pièces de rechange

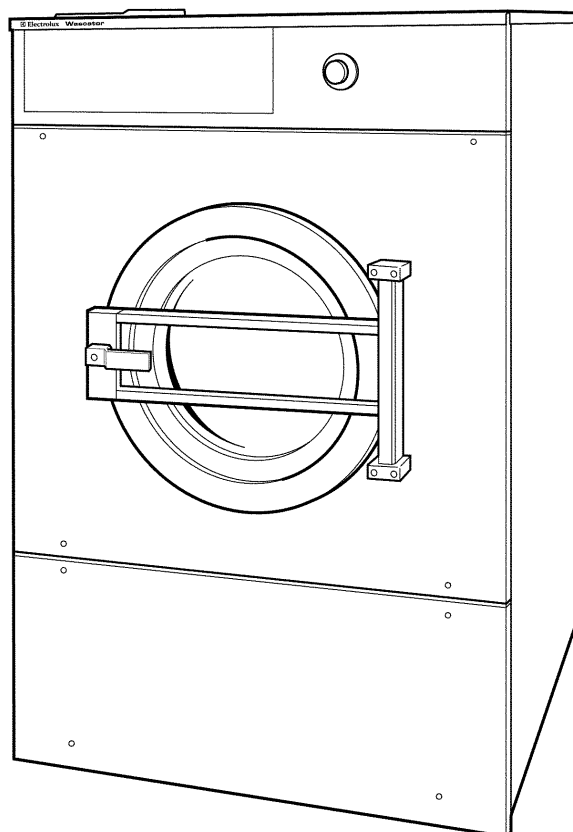

W245, FL245, SELECTA 245

List of versions

FL245,FL245 HI-TEK,SELECTA 28,W245,W245 EMERALD

Illustration	Page	Table of contents
101073	51	Steam components
101123	23	Door locking system
101384	9	Base and outer drum
101385	7	Panels
101386	25	Door
101387	27	Back plate with inner drum
101389	11	Control panel
101391	49	Connections components
101406	29	Motor bracket and motors
101407	53	Cables
101440	41	Control unit
101441	43	Control unit
101442	45	Control unit P03
101444	13	Control panel
101445	17	Control panel
101446	33	Water connections
101447	35	Water connections
101448	19	Control panel without coin meter
101449	21	Control panel with coin meter
101450	37	Water connections
101451	31	Hoses
101465	15	Control panel
101466	47	Control unit
101467	39	Water connections
101470	55	Cables P03
101472	57	Cables
101615	59	Cables

FL245,FL245 HI-TEK,SELECTA 28,W245,W245 EMERALD

Table of contents	Table des matières	Page/Page
Panels	Plaques	7
Base and outer drum	Base et tambour externe	9
Control panel	Pignon arrière avec tambour intérieur	11
Control panel	Pignon arrière avec tambour intérieur	13
Control panel	Pignon arrière avec tambour intérieur	15
Control panel	Pupitre de commande	17
Control panel without coin meter	Pupitre de commande sans monnayeur	19
Control panel with coin meter	Pupitre de commande, monnayeur	21
Door locking system	Serrure de porte	23
Door	Plaque	25
Back plate with inner drum	Pignon arrière avec tambour intérieur	27
Motor bracket and motors	Support moteur et moteurs	29
Hoses	Flexibles	31
Water connections	Raccords d'eau	33
Water connections	Raccords d'eau	35
Water connections	Raccords d'eau	37
Water connections	Raccords d'eau	39
Control unit	Unité de commande	41
Control unit	Unité de commande	43
Control unit P03	Unité de contrôle P03	45
Control unit	Unité de commande	47
Connections components	Composants de raccordement	49
Steam components	Composants	51
Cables	Câble	53
Cables P03	Câblage P03	55
Cables	Câble	57
Cables	Câble	59

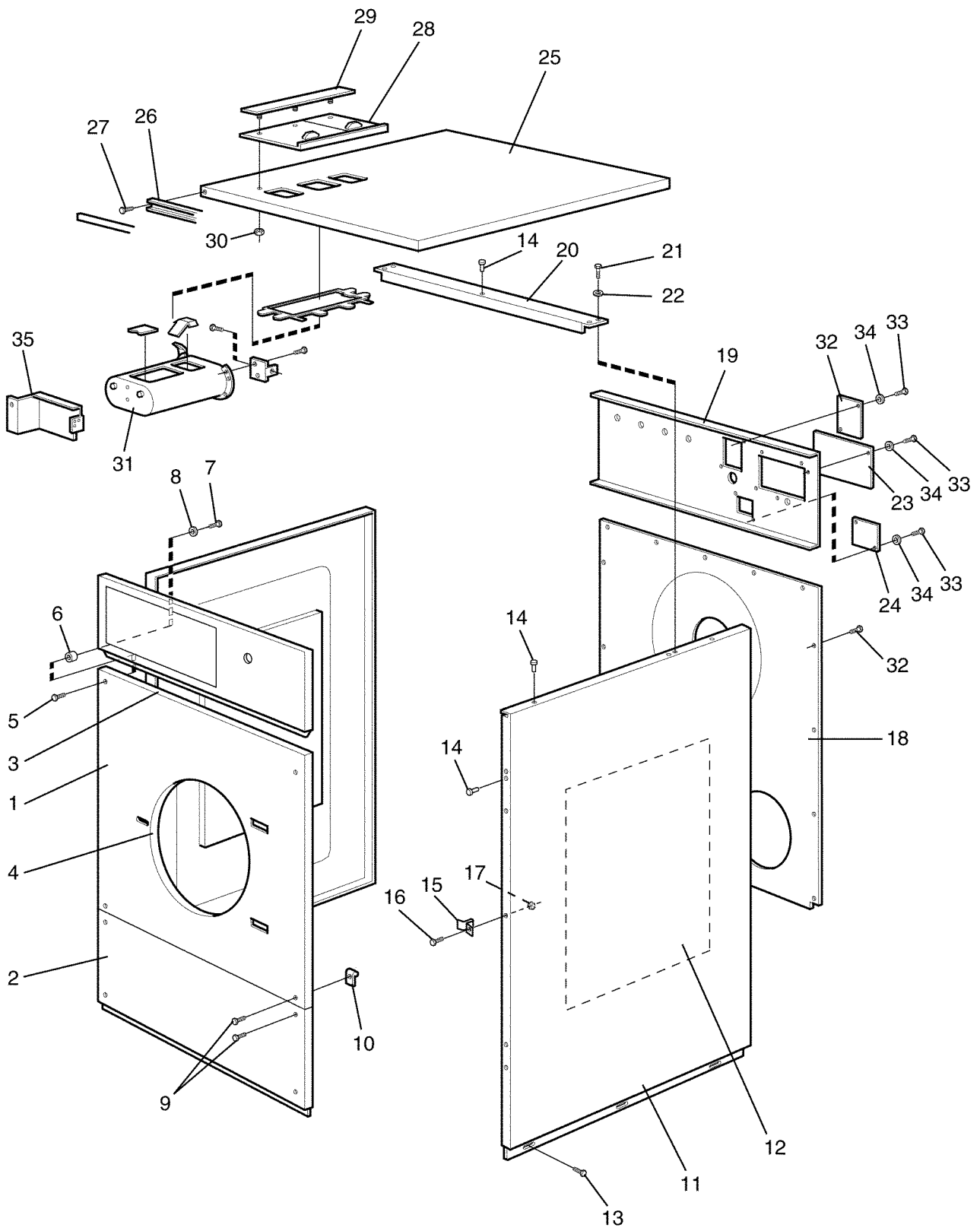

Issue	Month	Year
01	06	96

FL245,FL245 HI-TEK,SELECTA 28,W245,W245 EMERALD

Panels

Illustration Issue Month Year
Schéma Issue Month Year
101385 2 11 1996

Plaques

Item Article	Qua. Qua.	Art.No Réf. article	Description	Description	Info Info	Notes Remarques
1	1	438 4171-01	Front panel	Panneau avant	3	Stainless steel
	1	438 4171-03	Front panel	Panneau avant	3	Blue
	1	438 4171-04	Front panel	Panneau avant	3	Yellow
	1	438 4171-05	Front panel	Panneau avant	3	Red
	1	438 4171-06	Front panel	Panneau avant	3	White
	1	438 4171-07	Front panel	Panneau avant	3	Almond
	2	1	438 4172-01	Front panel	Panneau avant	3
1		438 4172-03	Front panel	Panneau avant	3	Blue
1		438 4172-04	Front panel	Panneau avant	3	Yellow
1		438 4172-05	Front panel	Panneau avant	3	Red
1		438 4172-06	Front panel	Panneau avant	3	White
1		438 4172-07	Front panel	Panneau avant	3	Almond
3		1	471 8158-02	Gasket	Joint	3
4	1	471 2440-35	Strip	Ruban	3	
5	8	471 8344-22	Screw	Vis	3	MRT 5X8
6	2	471 8405-01	Nut	Écrou	3	M5
7	2	471 8341-22	Screw	Vis	3	MRT 5X8
8	2	735 2146-01	Washer	Rondelle	3	M5 5,3
9	6	471 8344-35	Screw	Vis	3	M6X16
10	6	471 7864-01	Clip	Colliers de serrage	3	M6
11	2	438 0524-01	Side panel	Panneau latéral	3	White
	2	438 0524-02	Side panel	Panneau latéral	3	Red
	2	438 0524-03	Side panel	Panneau latéral	3	Stainless steel
12	2	471 7559-07	Insulating disc	Couche isolante	3	400X700
13	6	725 2366-61	Screw	Vis	3	M6SF 6X12
14	8	471 8641-01	Plug	Fiche	3	
15	2	471 2441-06	Bracket	Pièce de retenue	3	
16	2	471 8341-13	Screw	Vis	3	MRT 4X10
17	2	732 2112-01	Locking nut	Contre-écrou	3	M4
18	1	438 0528-01	Rear panel	Panneau arrière	3	EL/HW
	1	438 0528-02	Rear panel	Panneau arrière	3	
19			Brace bracket	Support de montant		Red
20	1	438 0532-01	Brace bracket	Support de montant	3	
21	4	725 2289-61	Screw	Vis	3	M4X10
22	4	735 2136-01	Lock washer	Rondelle d'arrêt	3	AZ 4,3 4,3
23	1	438 4244-01	Cover	Couvercle	3	
24	1	438 0358-02	Cover	Couvercle	3	
25	1	472 9163-08	Top panel	Couvercle	3	
	1	472 9163-09	Top panel	Couvercle	3	
26	1	471 7909-05	Rail	Support	3	
27	3	471 8452-01	Pop rivet	Rivet	3	
28	1	438 0079-01	Cover	Couvercle	1	
29	1	472 6145-03	Rail	Support	3	
30	3	731 2312-42	•Nut	•Écrou	3	M4
31	1		Detergent container	Compartiment à savon		2F-1H See group US8803
32	1	471 2410-22	Cover	Couvercle	3	
33	RQ	471 8340-23	Screw	Vis	3	RTS 4,2X13
34	RQ	735 2136-01	Lock washer	Rondelle d'arrêt	3	AZ 4,3 4,3
35	1	438 4178-01	Bracket	Support de montage	3	
36	1	471 7826-10	Lock	Serrure	1	
37	1	471 7826-98	Nut	Écrou	3	
38	1	471 7826-20	Key	Touche	1,2	FH025
39	1	438 2807-11	Type plate	Numéro série plaque	3	W 330MP

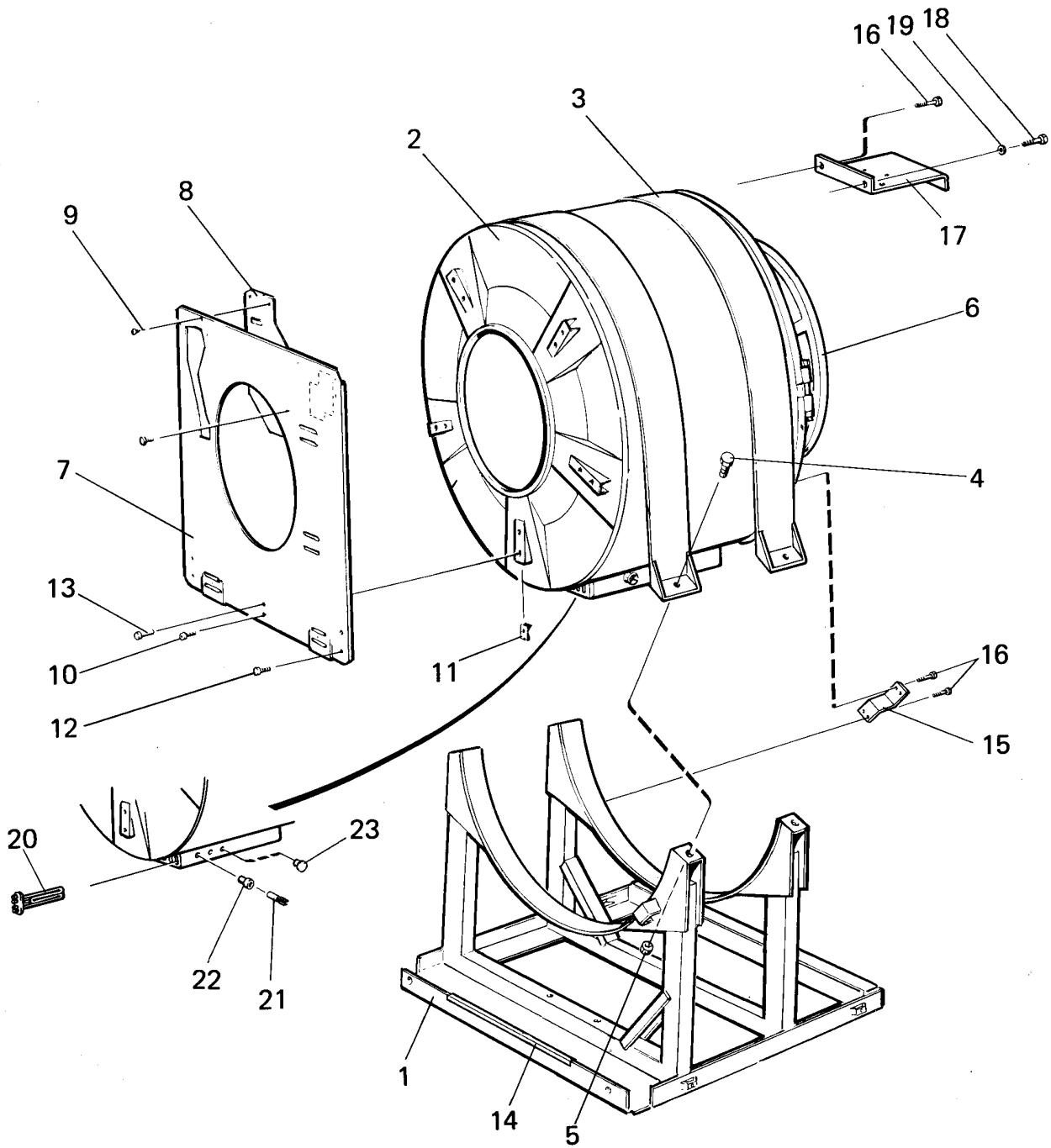

FL245,FL245 HI-TEK,SELECTA 28,W245,W245 EMERALD

Base and outer drum

Illustration Issue Month Year
Schéma Issue Month Year
101384 4 11 2000

Base et tambour externe

Item Article	Qua. Qua.	Art.No Réf. article	Description	Description	Info Info	Notes Remarques
1	1	471 4469-03	Frame	Base	3	
2	1	438 0527-01	Outer drum	Extérieur du tambour	1	Hot water
	1	438 0527-02	Outer drum	Extérieur du tambour	1	EL.
	1	438 0527-03	Outer drum	Extérieur du tambour	1	
3	2	471 2439-70	Tension strap	Extenseur	3	
4	4	725 2632-51	Screw	Vis	3	M16X60
5	4	732 2124-01	Locking nut	Contre-écrou	3	M16
6	1	438 0522-01	Back plate	Pignon arrière	3	
7	1	438 4155-01	End piece	Pignon	3	
8	1	438 4157-01	Plate	Plaque	3	
9	4	725 2366-61	Screw	Vis	3	M6SF 6X12
10	10	471 8341-46	Screw	Vis	3	M6X16
11	10	471 7864-01	Clip	Colliers de serrage	3	M6
12	2	725 2366-61	Screw	Vis	3	M6SF 6X12
13	1	471 8641-01	Plug	Fiche	3	
14	1	471 8180-12	Strip	Ruban	3	
15	1	471 2439-87	Bracket	Support de montage	3	
16	6	725 2366-61	Screw	Vis	3	M6SF 6X12
17	1	438 0523-01	Brace bracket	Support de montant	3	
18	2	729 9342-81	Screw	Vis	3	B8X13
19	2	725 2136-01	Lock washer	Rondelle d'arrêt	3	4,3
20	6	471 9811-01	Heating element	Élément de chauffage	1,2	4KW 230V
	6	471 9811-03	Heating element	Élément de chauffage	1,2	4KW, 254V
21	1	472 9913-22	Sensor	Captur	1,2	Complete HI-TEK,EMERALD
22	3	471 8192-01	•Bushing	•Douille	1,2	
23	RQ	438 4118-01	Plug	Fiche	3	

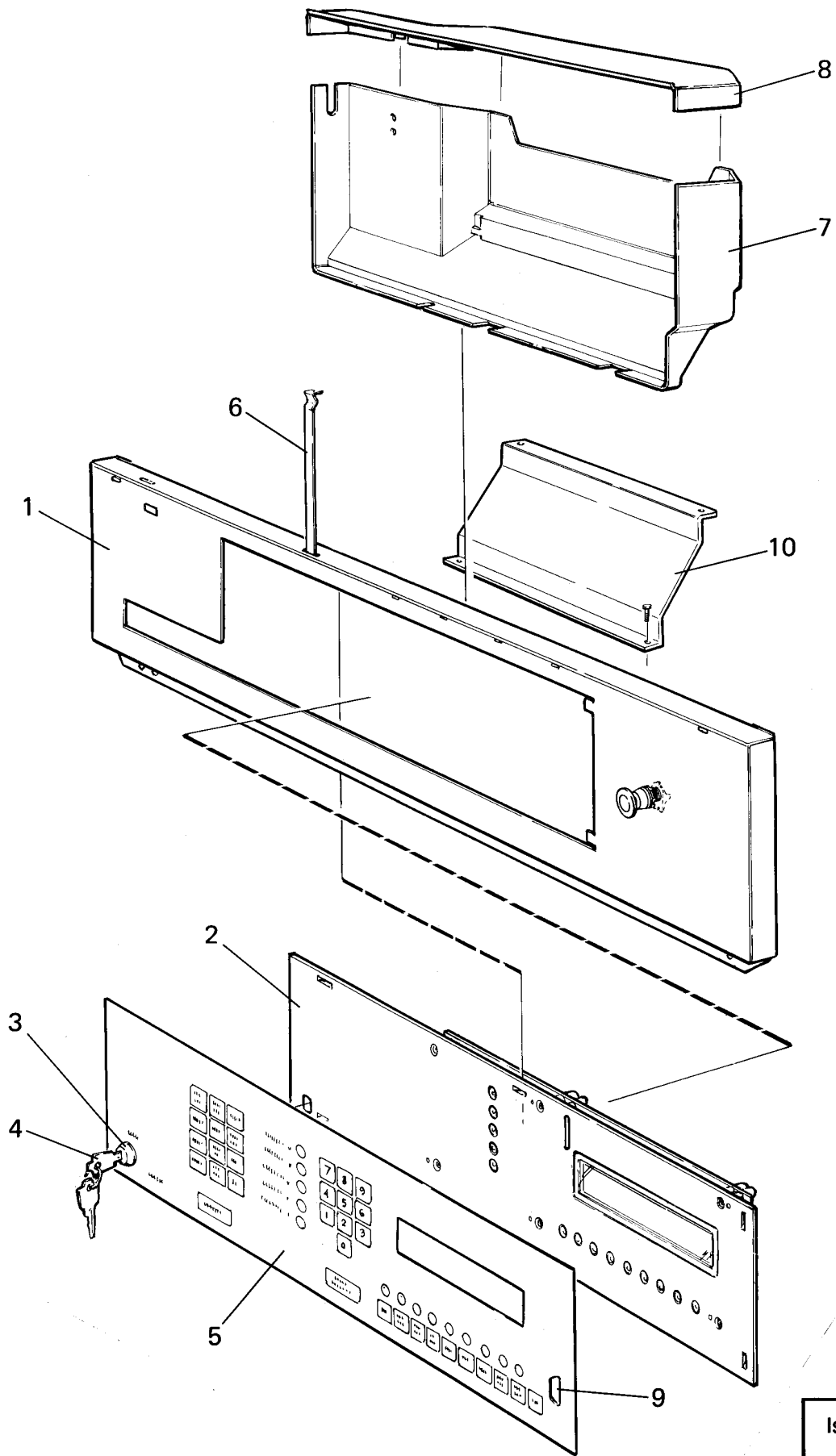

101389

Issue	Month	Year
01	06	96

FL245 HI-TEK

Control panel

Pignon arrière avec tambour intérieur

Illustration	Issue	Month	Year
Schéma	Issue	Month	Year
101389	2	1	1999

Item Article	Qua. Qua.	Art.No Réf. article	Description	Description	Info Info	Notes Remarques
1	1	471 4782-80	Control panel	Pupitre de commande	3	Black
2	1	471 8977-25	Printed circuit board	Circuit imprimé	1,2	
3	1	471 4878-84	Switch	Commutateur	1,2	
4	1	471 8733-10	•Key	•Touche	1	
5	1	472 5756-01	Panel sign	Voyant du tableau	1,2	English
	1	472 5756-04	Panel sign	Voyant du tableau	1,2	German
	1	472 5756-07	Panel sign	Voyant du tableau	1,2	Polish
	1	472 5756-20	Panel sign	Voyant du tableau	1,2	RUMANIAN
	1	472 5756-09	Panel sign	Voyant du tableau	1,2	Spanish
	1	472 5756-15	Panel sign	Voyant du tableau	1,2	Italian
	1	472 5756-08	Panel sign	Voyant du tableau	1,2	French
6	2	471 4586-01	Lock plate	Gâche de serrure	3	
7	1	471 4714-04	Heat shield	Bouclier thermique	3	
8	1	471 4714-05	Heat shield	Bouclier thermique	3	
9			Memory cartridge	Cassette de mémoire		Swedish See group US8342
10	1	438 0699-01	Cover	Couvercle	3	

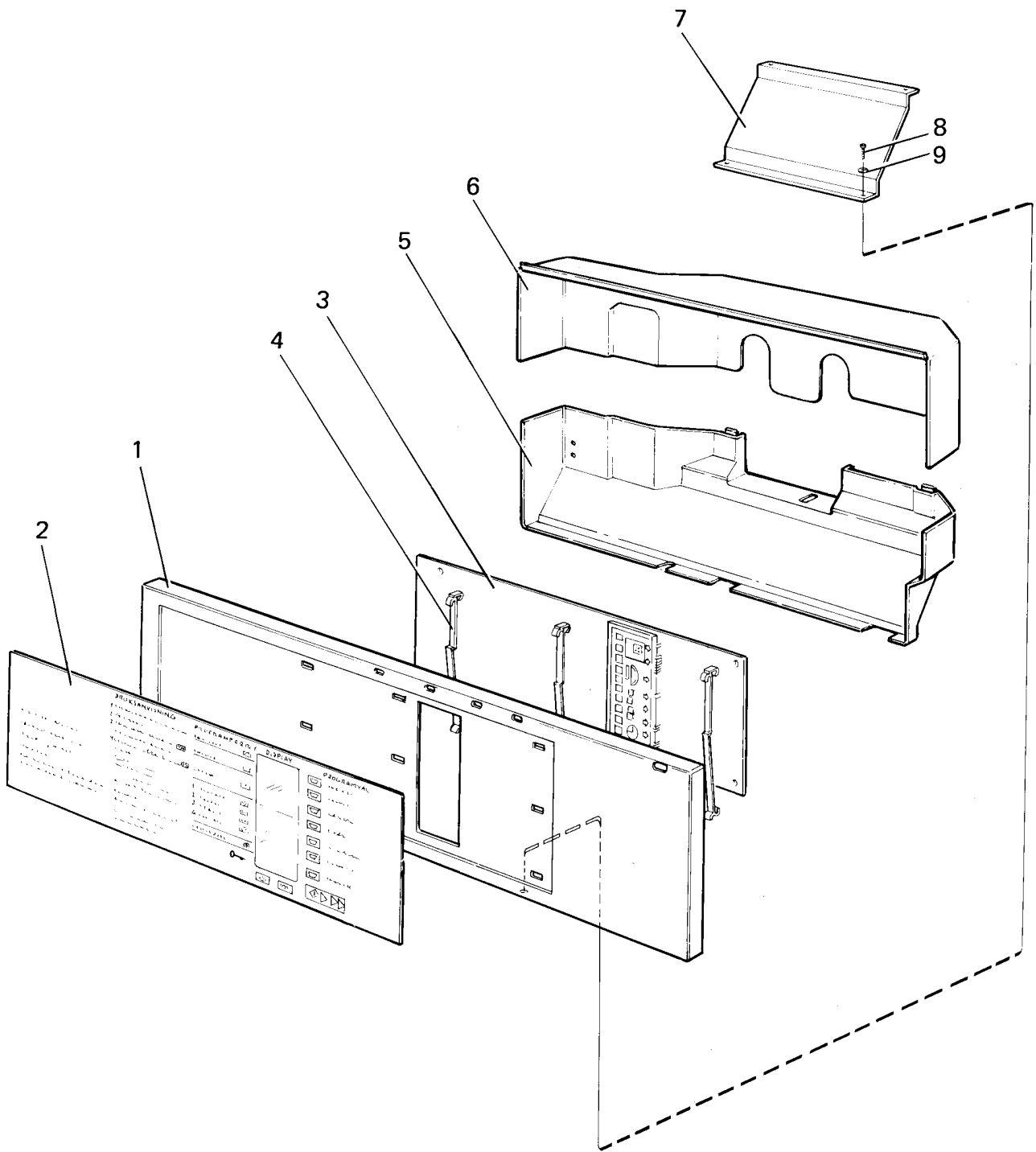

SELECTA 28

Control panel

Pignon arrière avec tambour intérieur

Illustration Issue Month Year
Schéma Issue Month Year
101444 1 3 1997

Item Article	Qua. Qua.	Art.No Réf. article	Description	Description	Info Info	Notes Remarques
1	1	471 4782-64	Control panel	Pupitre de commande	3	
2	1	472 5752-14	Panel sign	Voyant du tableau	1,2	
3	1	471 8964-09	Printed circuit board	Circuit imprimé	1,2	
4	3	472 8969-03	Bracket	Pièce de retenue	3	
5	1	438 4009-01	Heat shield	Bouclier thermique	3	Lower
6	1	438 4009-02	Heat shield	Bouclier thermique	3	Upper
7	1	438 0699-01	Cover	Couvercle	3	
8	2	471 8340-23	Screw	Vis	3	RTS 4,2X13
9	2	735 2136-01	Lock washer	Rondelle d'arrêt	3	AZ 4,3 4,3

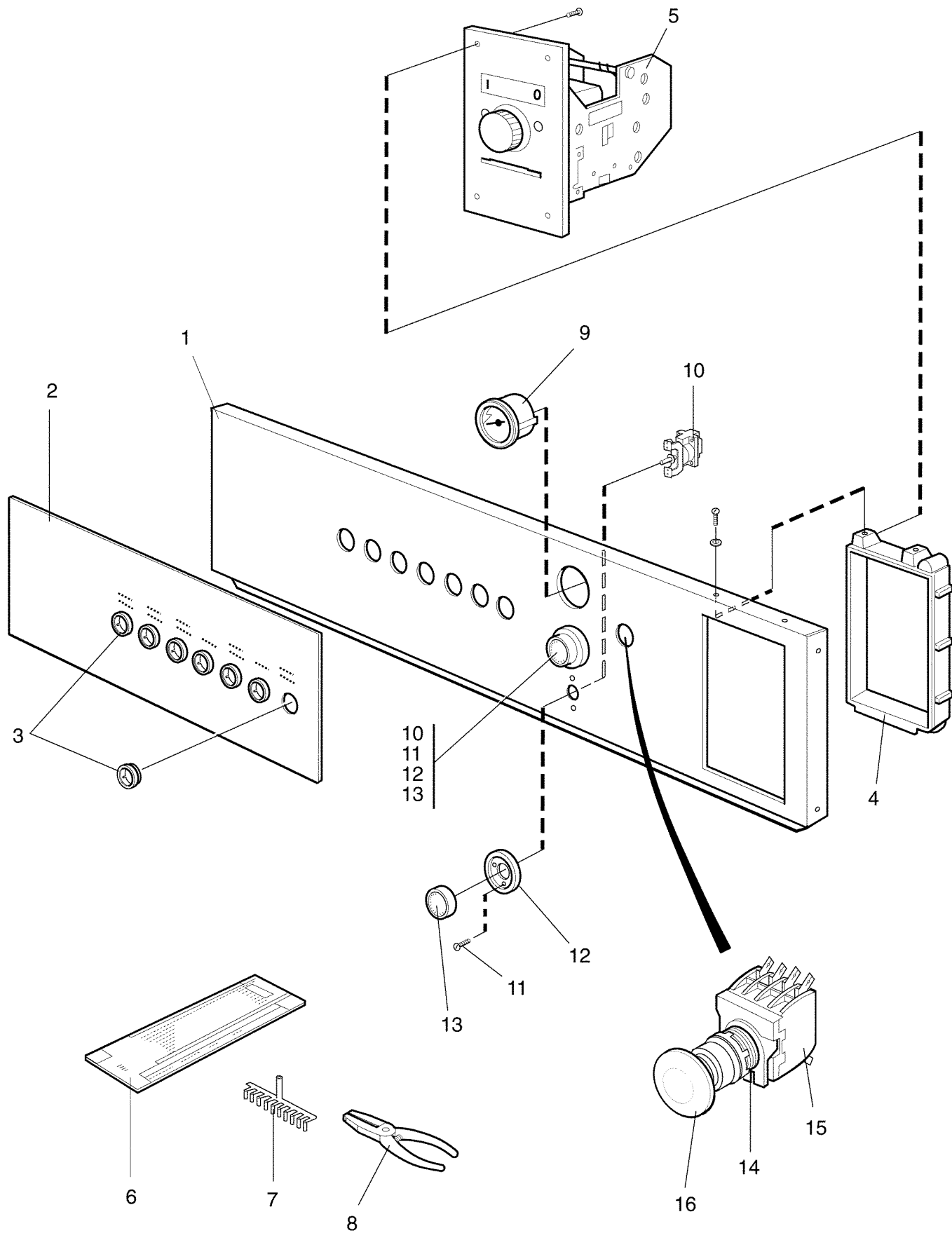

FL245

Control panel

Pignon arrière avec tambour intérieur

Illustration	Issue	Month	Year
Schéma	Issue	Month	Year
101465	2	9	1997

Item Article	Qua. Qua.	Art.No Réf. article	Description	Description	Info Info	Notes Remarques
1	1	471 4782-39	Control panel	Pupitre de commande	3	Black Non-heated
2	1	471 4527-79	User instructions	Instruction de fonctionnement	3	
3	7	472 6079-00	Grommet	Oeillet	3	French
4	1	471 4705-02	Frame	Châssis	3	
5	1		Card programmer	Programmeur cartes		50Hz See group US8337
6	1	471 8955-01	Program card	Carte programme	1,2	
	1	471 9219-16	Program card	Carte programme	1,2	
7	1	471 6654-10	Pin	Goupille	1	
8	1	471 8961-01	Pliers	Pince	1	
9	1	471 8810-02	Thermometer	Thermomètre	1,2	
10	2	471 8804-02	Thermostat	Thermostat	1,2	
11	4	471 8341-11	Screw	Vis	3	MRT 4X6
12	2	471 8804-71	Scale	Échelle	1	
13	2	471 8804-51	Handwheel	Bouton	1	
14						Not used
15						Not used
16						Not used

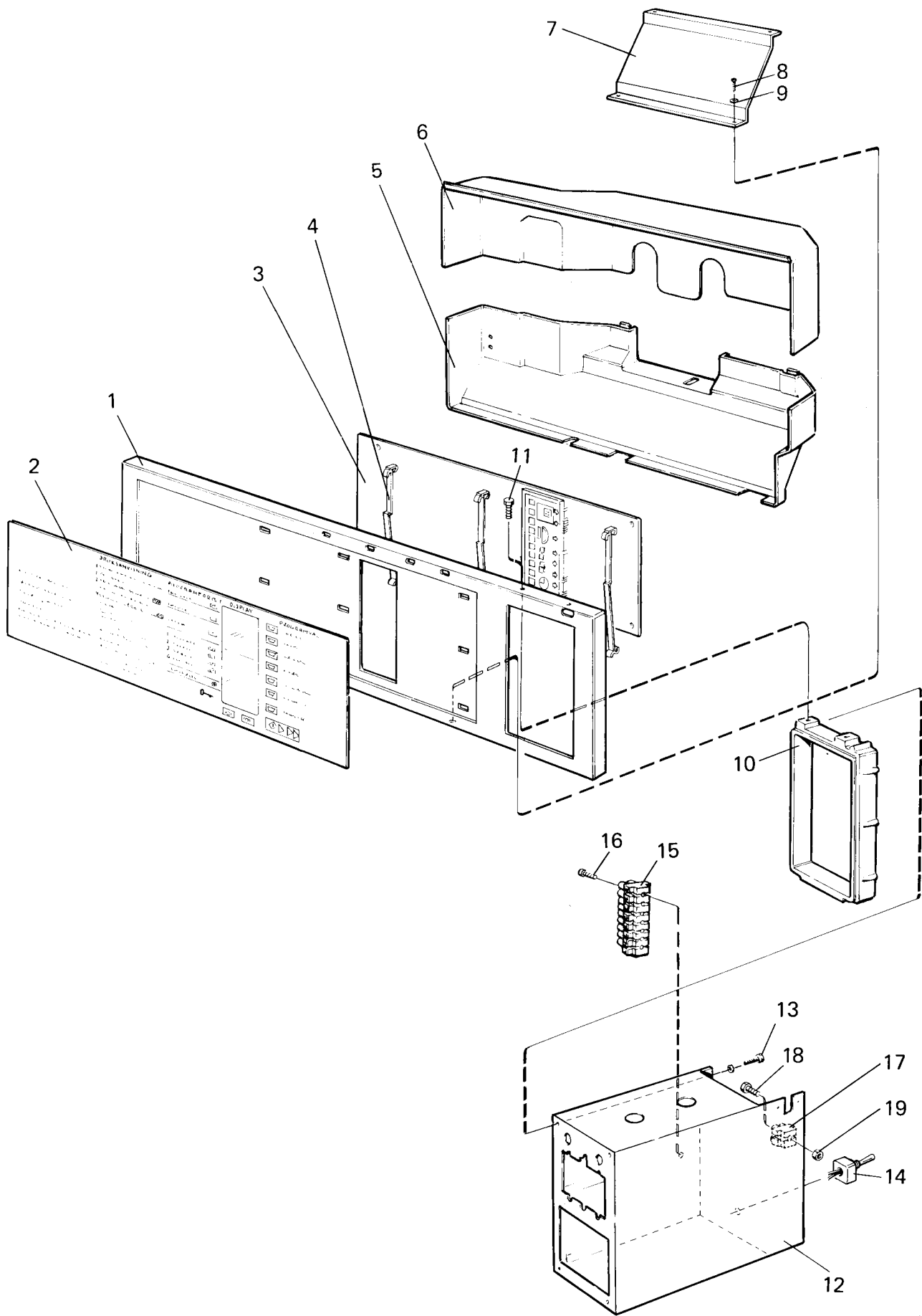

W245 EMERALD

Control panel

Pupitre de commande

Illustration Issue Month Year
Schéma Issue Month Year
101445 2 3 2000

Item Article	Qua. Qua.	Art.No Réf. article	Description	Description	Info Info	Notes Remarques
1	1	432 0919-03	Control panel	Panneau de commande	3	Emerald W245
2	1	472 5752-18	Panel sign	Voyant du tableau	1,2	USA
3	1	471 8964-09	Printed circuit board	Circuit imprimé	1,2	
4	3	472 8969-03	Bracket	Pièce de retenue	1	
5	1	438 4009-01	Heat shield	Bouclier thermique	3	Lower
6	1	438 4009-02	Heat shield	Bouclier thermique	3	Upper
7	1	438 0699-01	Cover	Couvercle	3	
8	2	471 8340-23	Screw	Vis	3	RTS 4,2X13
9	2	735 2136-01	Lock washer	Rondelle d'arrêt	3	AZ 4,3
10	1	471 4705-02	Frame	Châssis	3	
11	2	722 7843-02	Pop rivet	Rivet	3	
12	1	438 4088-01	Coin box	Boite à jetons	3	
13	4	471 8342-23	Screw	Vis	3	MRT-TT 5X10
14	1	471 9629-02	Switch	Commutateur	1,2	
15	1	762 7207-57	Terminal strip	Bloc de connexion	3	
16	2	471 8341-05	Screw	Vis	3	MRT 3X16
17	1	762 7202-57	Terminal strip	Bloc de connexion	3	2-pole
18	1	471 8341-07	Screw	Vis	3	MRT 3X25
19	1	732 2110-01	Locking nut	Contre-écrou	3	M3

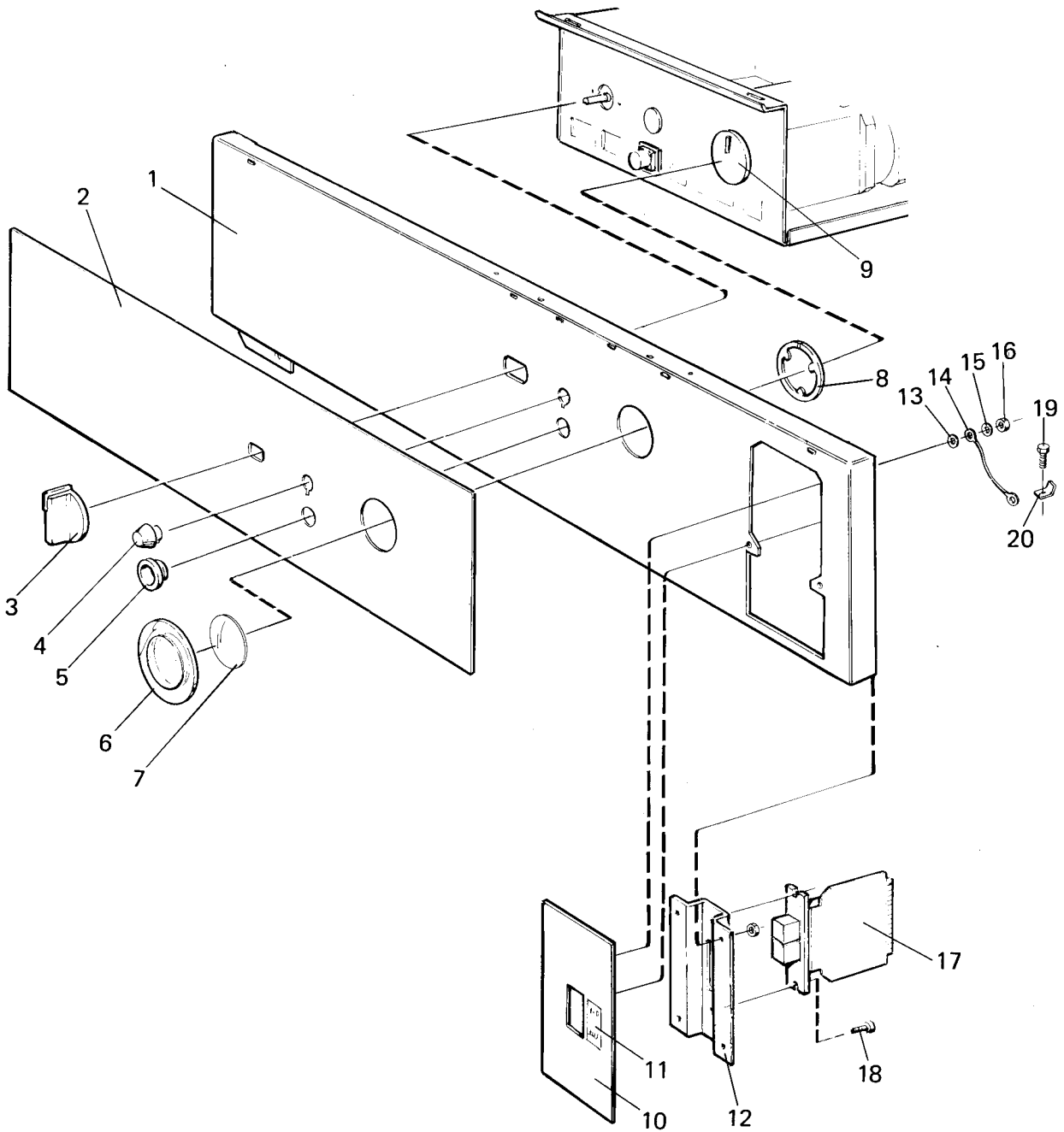

W245

Control panel without coin meter

Pupitre de commande sans monnayeur

Illustration Issue Month Year
Schéma Issue Month Year
101448 1 11 1996

Item Article	Qua. Qua.	Art.No Réf. article	Description	Description	Info Info	Notes Remarques
1	1	471 4782-38	Control panel	Pupitre de commande	3	Black
2	1	471 4525-31	User instructions	Instruction de fonctionnement	3	ENGLISH, SILVER
3	1	438 0076-01	Knob	Bouton	1,2	Complete
4	1	763 1802-01	Glass	Verre	1	Red
5	1	472 6079-00	Grommet	Oeillet	3	French
6	1	471 4829-01	Safety glass	Verre de sécurité	1,2	
7	1	471 4862-01	Glass	Verre	1,2	
8	1	471 4830-01	Locking ring	Jonc de verrouillage	1	
9	1	472 6082-01	Pointer	Indicateur	1	
10	1	438 0334-02	Cover plate	Plaque recouvrement	3	Black
11	1	471 4657-82	Sign	Signe	3	
12	1	471 4904-02	Bracket	Pupitre	3	
13	1	735 2136-01	Lock washer	Rondelle d'arrêt	3	AZ 4,3 4,3
14	1	438 3019-21	Cables	Câble	3	
15	4	734 1808-51	Washer	Rondelle	3	NB 5X16
16	8	732 2112-01	Locking nut	Contre-écrou	3	M4
17	1	471 9642-03	Pushbutton unit	Poste bouton-poussoir	1,2	
18	2	725 2289-61	Screw	Vis	3	M4X10
19	1	471 8342-13	Screw	Vis	3	MRT-TT 4X10
20	1	735 2136-01	Lock washer	Rondelle d'arrêt	3	AZ 4,3 4,3

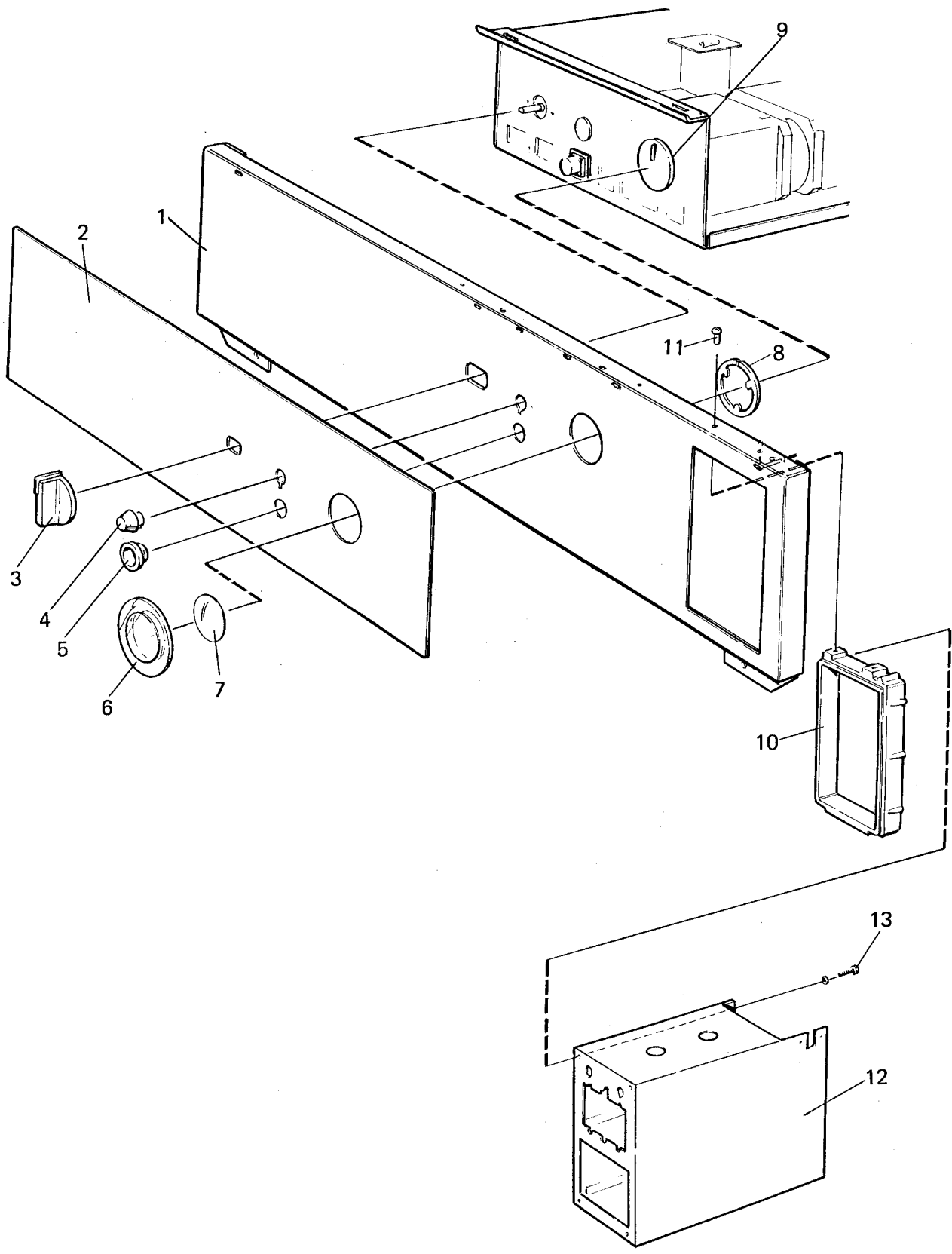

W245

Control panel with coin meter

Pupitre de commande, monnayeur

Illustration Issue Month Year
Schéma Issue Month Year
101449 1 11 1996

Item Article	Qua. Qua.	Art.No Réf. article	Description	Description	Info Info	Notes Remarques
1	1	471 4782-38	Control panel	Pupitre de commande	3	Black
2	1	471 4525-32	User instructions	Instruction de fonctionnement	3	
3	1	438 0076-01	Knob	Bouton	1,2	Complete
4	1	763 1802-01	Glass	Verre	1	Red
5	1	472 6079-00	Grommet	Oeillet	3	French
6	1	471 4829-01	Safety glass	Verre de sécurité	1	
7	1	471 4862-01	Glass	Verre	1	
8	1	471 4830-01	Locking ring	Jonc de verrouillage	3	
9	1	472 6082-01	Pointer	Indicateur	1	
10	1	471 4705-02	Frame	Châssis	3	
11	2	722 7843-02	Pop rivet	Rivet	3	
12	1	438 4088-01	Coin box	Boite à jetons	3	
13	4	471 8342-23	Screw	Vis	3	MRT-TT 5X10

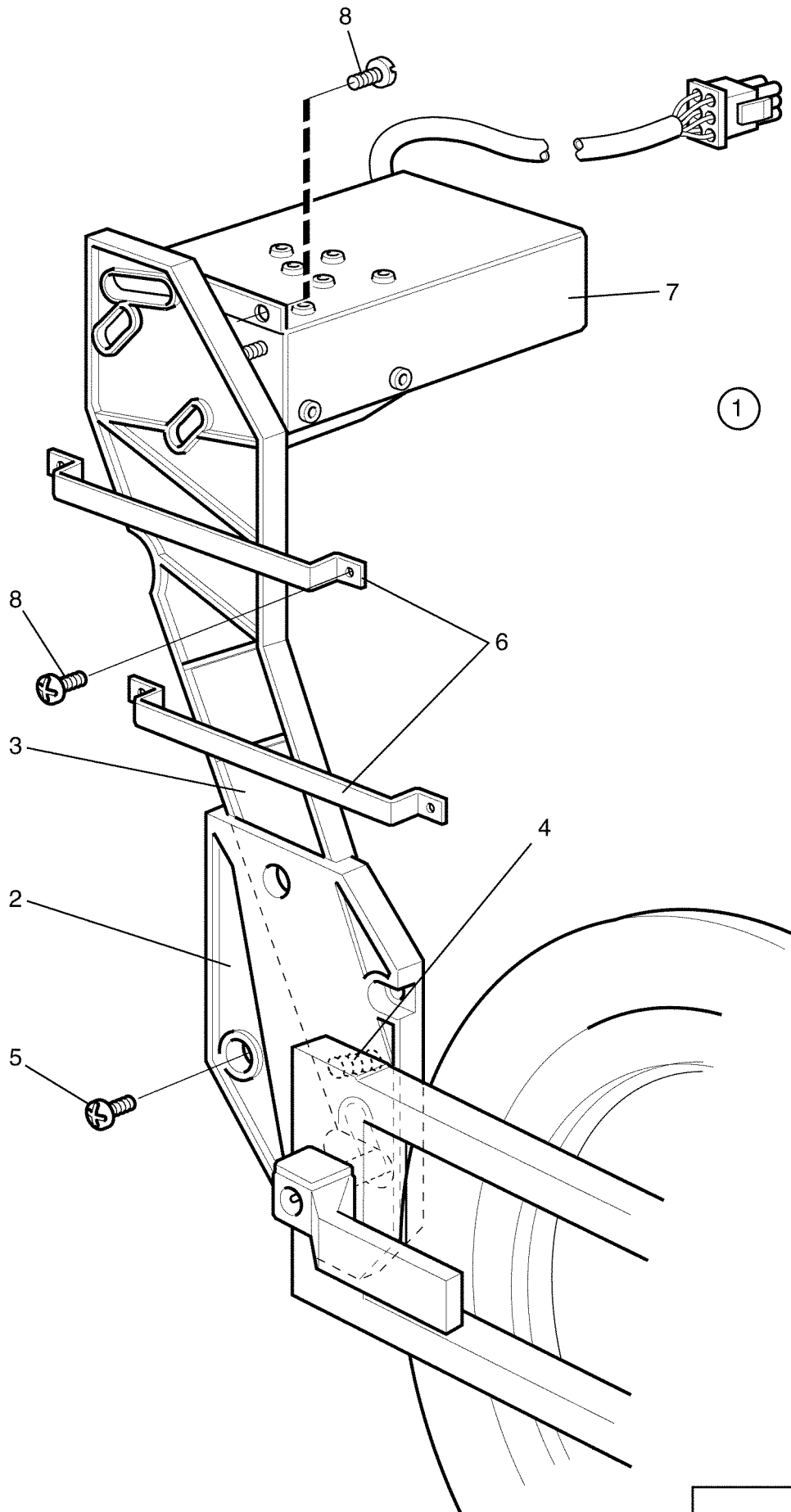

FL245,FL245 HI-TEK,SELECTA 28,W245,W245 EMERALD

Door locking system

Serrure de porte

Illustration	Issue	Month	Year
Schéma	Issue	Month	Year
101123	2	11	1996

Item Article	Qua. Qua.	Art.No Réf. article	Description	Description	Info Info	Notes Remarques
1	1	438 4150-01	Locking unit	Unité verrouillage	1	Complete
2	1	438 4148-02	•Plate	•Tableau	3	
3	1	438 4147-02	•Arm	•Bras	3	
4	1	471 7803-21	•Spring	•Ressort	3	
5	4	725 2370-61	•Screw	•Vis	3	M6SF 6X20
6	2	472 9187-01	•Clamp	•Bride de fixation	3	
7	1	438 4152-01	•Locking unit	•Unité verrouillage	1,2	See group US8711

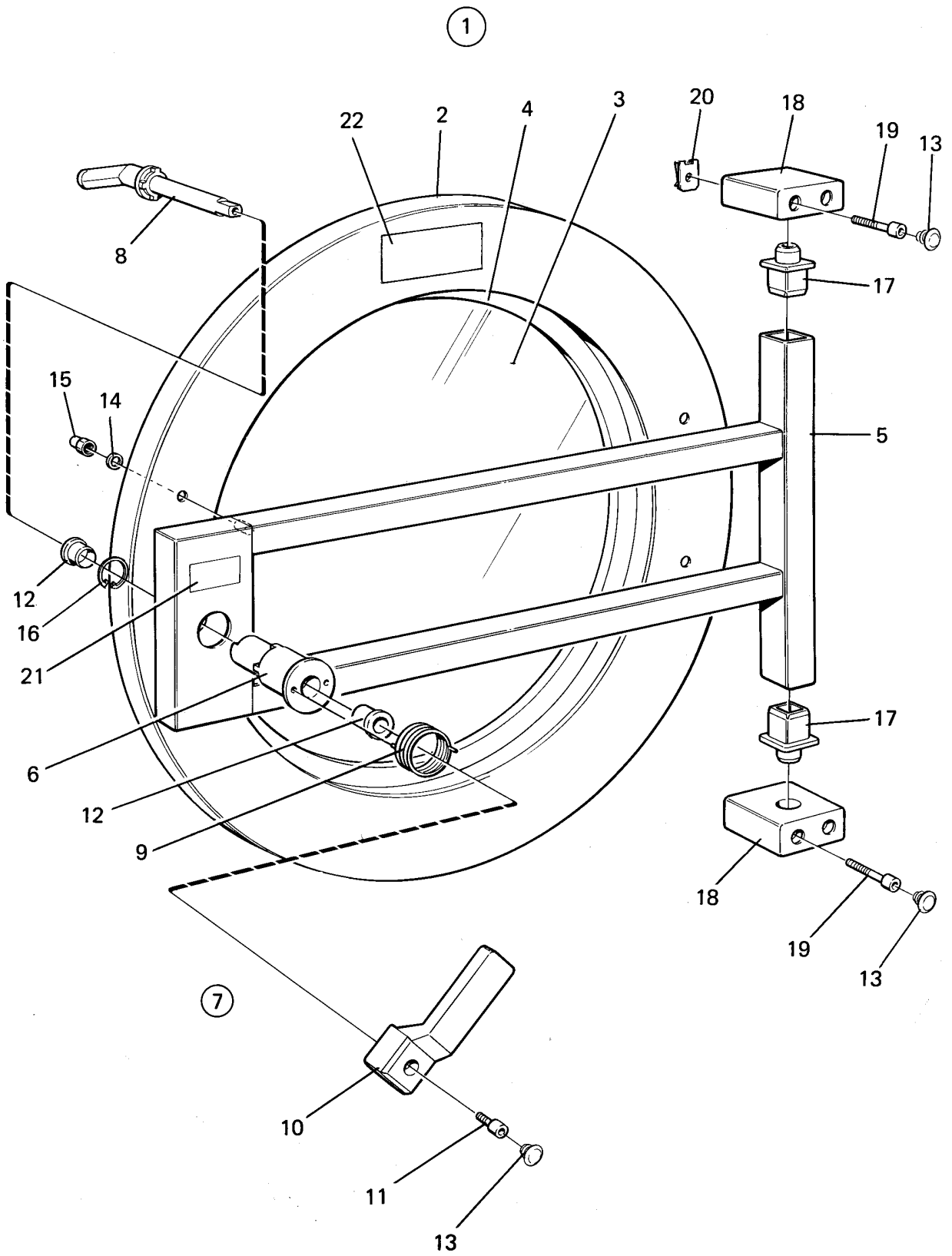

101386

Issue	Month	Year
01	06	96

FL245,FL245 HI-TEK,SELECTA 28,W245,W245 EMERALD

Door

Illustration Issue Month Year
Schéma Issue Month Year
101386 2 11 1996

Plaque

Item Article	Qua. Qua.	Art.No Réf. article	Description	Description	Info Info	Notes Remarques
1	1	438 4326-01	Door	Plaque	1,2	Complete
2	1	438 4130-01	•Door ring	•Anneau de la porte	3	
3	1	471 2431-28	•Door glass	•Vitre de la porte	1,2	
4	1	471 2431-29	•Door gasket	•Joint de la porte	1,2	Black
5	1	438 4117-02	•Bracket	•Pupitre	3	
6	1	438 4126-02	••Hub	••Moyeu	1	
7	1	472 9901-08	••Door handle	••Poignée de la porte	1,2	
8	1	438 0426-01	•••Shaft	•••Arbre	3	
9	1	471 7814-02	•••Spring	•••Ressort	1	
10	1	438 4127-02	•••Handle	•••Poignée	1,2	
11	1	471 8341-85	•••Screw	•••Vis	3	M6X16
12	2	438 0033-01	•••Bushing	•••Douille	3	
13	1	471 7961-02	•••Plug	•••Fiche	3	
14	4	734 1153-09	••Washer	••Rondelle	3	BRB 6,4X12
15	4	732 3116-14	••Nut	••Écrou	3	M6
16	1	735 3126-01	••Circlip	••Attache en forme C	3	
17	2	438 4132-02	••Pin	••Goupille	3	
18	2	438 4128-01	Hinged joint	Assemblage articulé	3	
19	4	471 8341-50	Screw	Vis	3	MRT 6X50
20	4	471 7864-01	Clip	Colliers de serrage	3	M6
21	1	471 7668-02	Warning sign	Signal avertissement	3	English
22	1	471 7671-65	Warning sign	Signal avertissement	3	

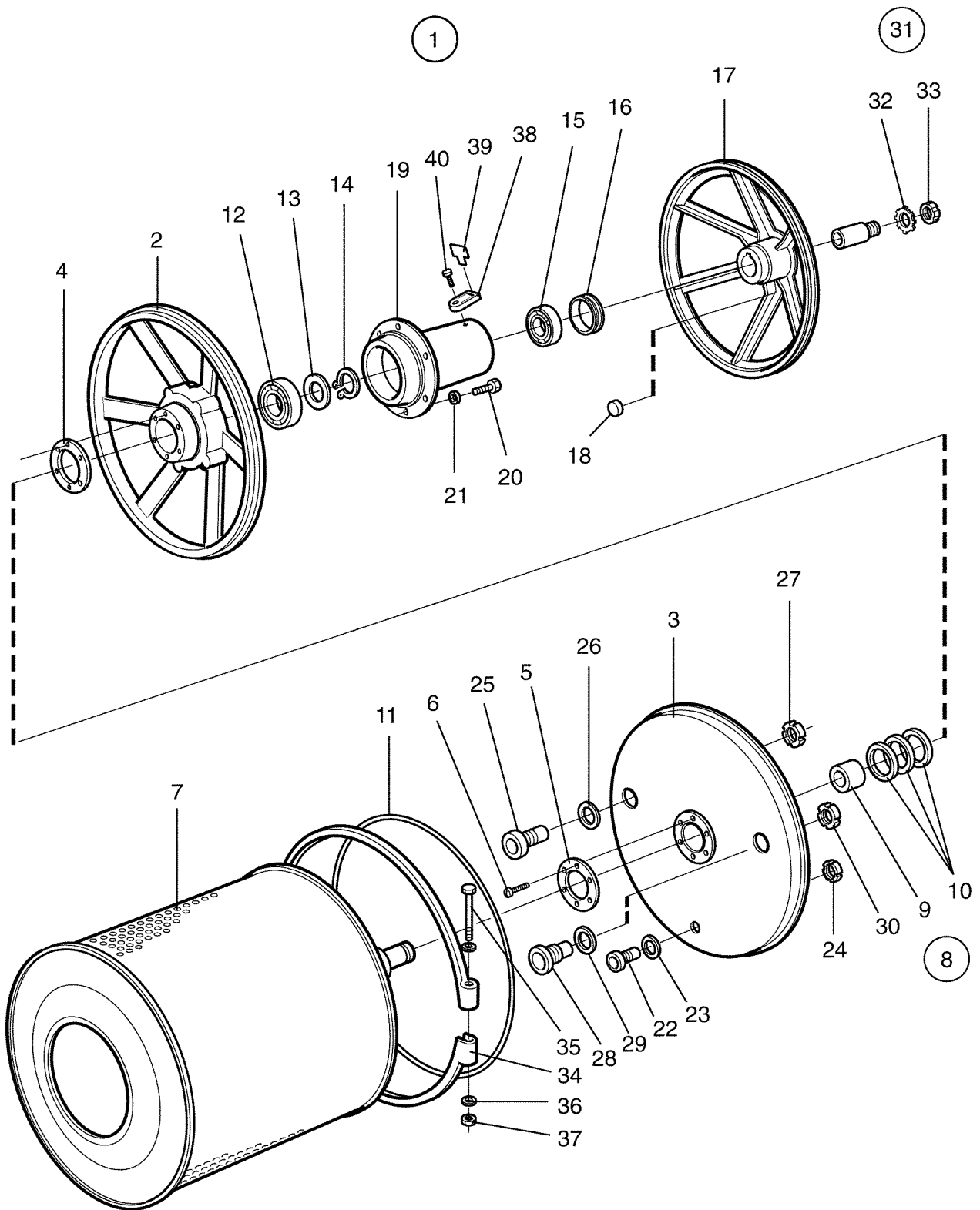

FL245,FL245 HI-TEK,SELECTA 28,W245,W245 EMERALD

Back plate with inner drum

Illustration Issue Month Year
Schéma Issue Month Year
101387/3 3 12 1999

Pignon arrière avec tambour intérieur

Item Article	Qua. Qua.	Art.No Réf. article	Description	Description	Info Info	Notes Remarques
1	1	438 0522-01	Back plate	Pignon arrière	1	Complete
2	1	471 2439-04	•Back plate	•Pignon arrière	3	
3	1	471 4417-01	•Plate	•Plaque	3	Stainless steel
4	1	471 2574-02	•Gasket	•Joint	1	
5	1	471 2440-89	•Washer	•Rondelle	3	
6	6	471 8311-00	•Screw	•Vis	3	M6SFTT 5X16
7	1	471 4447-01	•Inner drum	•Intérieur du tambour	1	
8	1	472 9902-11	•Maintenance kit	•Kit reconditionnement	1	
9	1		••Bushing	••Douille		
10	3		••Sealing ring	••Bague d'étanchéité		
11	1	471 2451-82	••Rubber strip	••Joint caoutchouc	1	
12	1		••Ball bearing	••Roulement à billes		
13	1		••Ring	••Anneau		
14	1		••C-clamp	••Presse à main		SGA 60
15	1		••Ball bearing	••Roulement à billes		
16	1		••O-ring	••Joint torique		
17	1	471 2539-00	•Pulley	•Poulie	1	
18	2	471 9560-01	••Magnet	••Aimant	1	
19	1	471 2074-85	•Bearing housing	•Logement de palier	3	-97/11034
	1	438 4093-01	•Bearing housing	•Logement de palier	3	97/11035-
20	6	725 2634-71	•Screw	•Vis	3	M16X60 -97/11034
	6	471 8328-04	•Screw	•Vis	3	M16X70 97/11035-
21	6	734 1186-01	•Washer	•Rondelle	3	BRB 17X30
22	1	438 0456-01	•Nipple	•Raccord	1	
23	1	471 2440-10	•Gasket	•Joint	1	
24	1	438 0457-01	•Nut	•Écrou	3	
25	1	438 0458-01	•Nipple	•Raccord	3	
26	1	471 2440-12	•Gasket	•Joint	1	
27	1	438 0459-01	•Nut	•Écrou	3	
28	1	438 4101-01	•Nipple	•Raccord	3	
29	1	471 2441-44	•Gasket	•Joint	1	
30	1	438 4100-01	•Nut	•Écrou	3	
31	1	471 8551-02	•Sleeve	•Manchon	3	
32	1	471 8512-01	••Lock washer	••Rondelle d'arrêt	3	
33	1	471 8402-01	••Nut	••Écrou	3	
34	2	471 2439-73	Tension strap	Extenseur	3	
35	2	471 9222-59	Screw	Vis	3	M8X140
36	4	471 8502-14	Washer	Rondelle	3	BRB 8,4X17
37	2	732 2118-01	Locking nut	Contre-écrou	3	M8

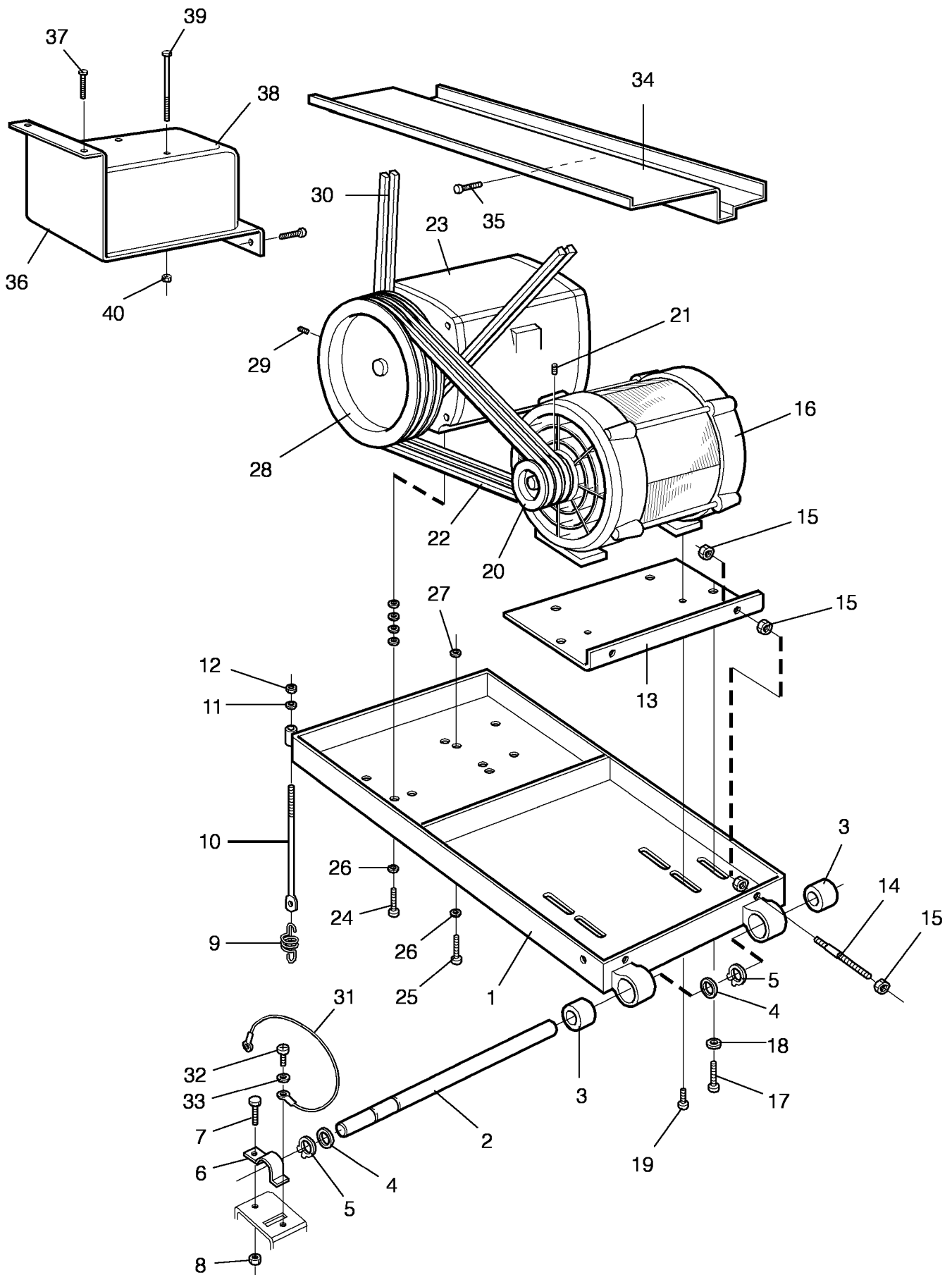

FL245,FL245 HI-TEK,SELECTA 28,W245,W245 EMERALD

Motor bracket and motors

Illustration Issue Month Year
Schéma Issue Month Year
101406 2 11 1996

Support moteur et moteurs

Item Article	Qua. Qua.	Art.No Réf. article	Description	Description	Info Info	Notes Remarques
1	1	471 4442-01	Motor shelf	Berceau	3	
2	1	471 2459-35	Shaft	Arbre	3	
3	2	471 2059-18	Rubber bushing	Douille caoutchouc	3	
4	2	734 1191-01	Washer	Rondelle	3	20X36
5	2	735 3122-20	Circlip	Attache en forme C	3	
6	1	471 2420-47	Clamp	Bride de fixation	3	
7	1	725 2372-51	Screw	Vis	3	M6X25
8	1	732 2116-01	Locking nut	Contre-écrou	3	M6
9	1	471 2439-90	Tensioner spring	Ressort tendeur	3	
10	1	471 2440-26			3	
11	1	471 8502-14	Washer	Rondelle	3	BRB 8,4X17
12	1	732 2118-01	Locking nut	Contre-écrou	3	M8
13	1	471 2538-00	Plate	Plaque	3	
14	2	471 2439-32	Screw	Vis	3	M8X95
15	8	731 2318-01	Nut	Écrou	3	M8
16	1	471 9714-21	Motor	Moteur	1,2	WASH, 400-415V50Hz/415-480V60Hz
	1	471 9714-22	Motor	Moteur	1,2	WASH, 190-200V50Hz/200-240V60Hz
	1	471 9714-23	Motor	Moteur	1,2	WASH,230V/400-415V 50Hz
	1	471 9714-25	Motor	Moteur	1,2	WASH,346V 50Hz/380V 60Hz
17	4	725 2453-51	Screw	Vis	3	M8X25
18	4	471 8502-31			3	
19	2	471 2440-27	Screw	Vis	3	
20	1	471 4647-66	Pulley	Poulie	3	
21	2	728 8362-01	Screw	Vis	3	SK6SS 6X8
22	3	471 7701-58	V-belt	Courroie trapézoïdale	1,2	
23	1	471 9718-21	Motor	Moteur	1,2	EXTR, 400-415V50Hz/415-480V60Hz
	1	471 9718-22	Motor	Moteur	1,2	EXTR, 190-200V50Hz/200-240V60Hz
	1	471 9718-23	Motor	Moteur	1,2	EXTR,230V 50Hz/400-415V 50Hz
	1	471 9718-25	Motor	Moteur	1,2	EXTR, 346V 50Hz/380V 60Hz
24	2	725 2449-51	Screw	Vis	3	M8X16
25	2	725 2451-51	Screw	Vis	3	M8X20
26	4	734 1164-01	Washer	Rondelle	3	8,4X17
27	2	471 8502-31			3	
28	1	471 4647-70	Pulley	Poulie	3	50Hz
	1	471 4647-68	Pulley	Poulie	3	60Hz
29	2	728 8362-01	Screw	Vis	3	SK6SS 6X8
30	2	471 9006-37	V-belt	Courroie trapézoïdale	1,2	
31	1	471 4878-05	Cables	Câble	3	
32	2	471 8340-22	Screw	Vis	3	4,2X9,5
33	1	735 2136-01	Lock washer	Rondelle d'arrêt	3	AZ 4,3
34	1	471 2535-01	Plate	Plaque	3	
35	2	725 2366-61	Screw	Vis	3	M6SF 6X12
36	1	438 0529-01	Mounting plate	Plaque de montage	3	
37	2	725 2289-61	Screw	Vis	3	M4X10
38	1	471 9550-10	Transformer	Transformateur	1	
39	3	725 2327-51	Screw	Vis	3	M5X12
40	3	732 2114-01	Locking nut	Contre-écrou	3	M5

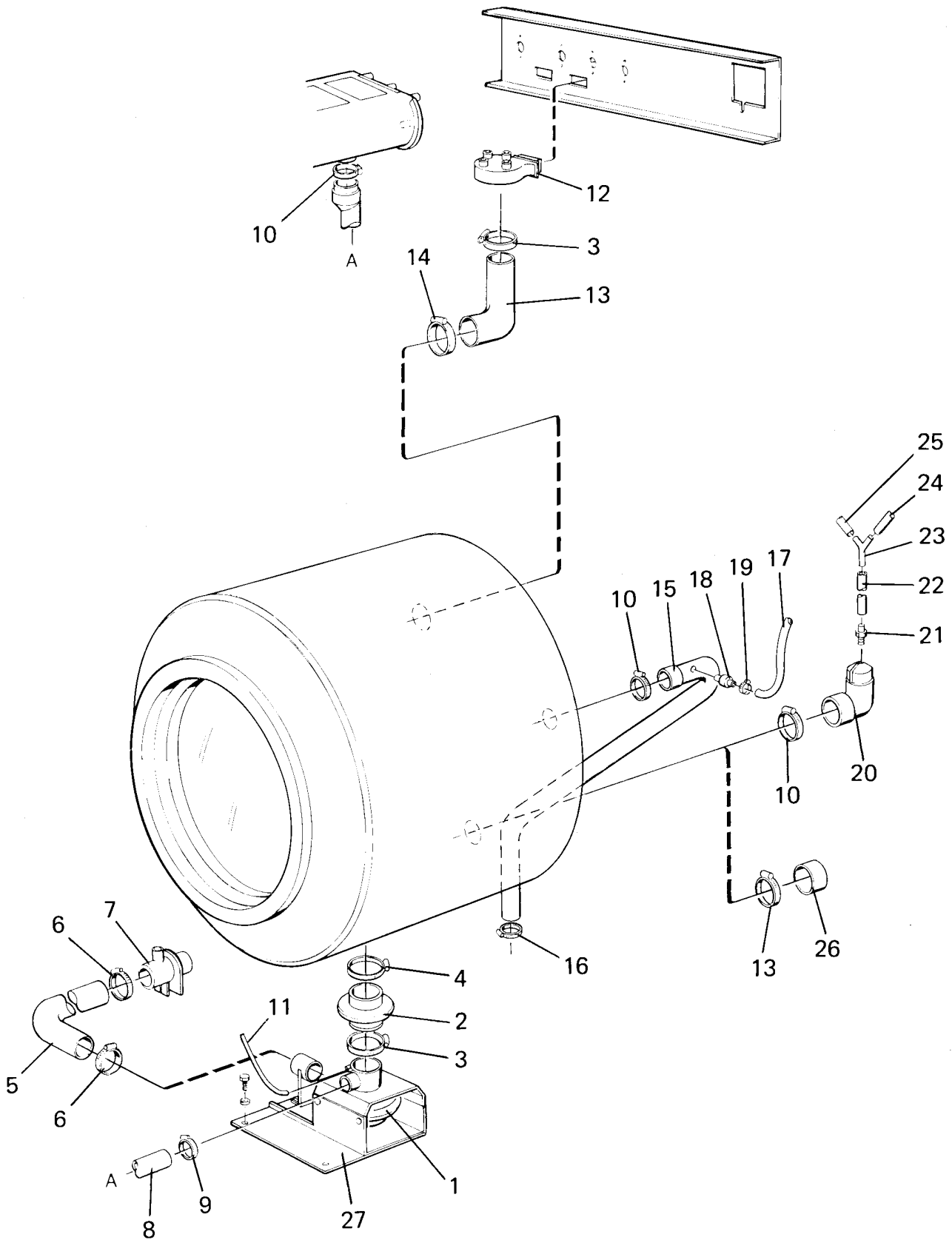

FL245,FL245 HI-TEK,SELECTA 28,W245,W245 EMERALD

Hoses

Flexibles

Illustration Issue Month Year
Schéma Issue Month Year
101451 1 11 1996

Item Article	Qua. Qua.	Art.No Réf. article	Description	Description	Info Info	Notes Remarques
1	1	472 6020-08	Drain valve	Purgeur	1,2	220V 50/60Hz Complete See group US8101
2	1	471 2904-01	Connection	Flexible caoutchouc	1	
3	2	736 2849-51	Hose clamp	Attache flexible	3	Ø77-93
4	1	471 7851-03	Hose clamp	Attache flexible	3	Ø95-115
5	1	471 4401-01	Hose	Flexible	1	
6	2	736 2849-51	Hose clamp	Attache flexible	3	Ø77-93
7	1	471 4521-01	Connection	Flexible caoutchouc	3	
8	1	471 4427-01	Hose	Flexible	1	
9	1	736 2837-51	Hose clamp	Attache flexible	3	Ø48-54
10	3	736 2840-51	Hose clamp	Attache flexible	3	Ø50-63
11	1	471 2425-28	Hose	Flexible	1,2	L=1500
12	1	471 4516-03	Air inlet	Prise d'air	3	
13	1	471 4437-02	Hose	Flexible	1	
14	1	736 2846-51	Hose clamp	Attache flexible	3	Ø73-83
15	1	471 4403-02	Hose	Flexible	1	
16	1	736 2831-51	Hose clamp	Attache flexible	3	Ø36-42
17	1	471 2449-72	Hose	Flexible	1	
18	1	471 2432-25	Hose nipple	Mamelon de flexible	3	
19	2	736 2816-51	Hose clamp	Attache flexible	3	Ø13-19
20	1	471 2095-32	Air chamber	Chambre à air	1	
21	1	471 2401-52	Nipple	Raccord	3	
22	1	471 8118-06	Hose	Flexible	1	L=1900, HI-TEK
	1	471 2438-31	Hose	Flexible	1	L=1350, FL
23	2	471 2265-69	T-pipe	Tube en T	3	
24	1	471 2440-36	Hose	Flexible	1	L=90 L=90
25	1	471 2440-37	Hose	Flexible	1	L=160
26	1	471 2416-83	Hood	Capot	3	
27	1	471 4402-01	Bracket	Pupitre	3	HW,DS
	1	471 4402-02	Bracket	Pupitre	3	El.

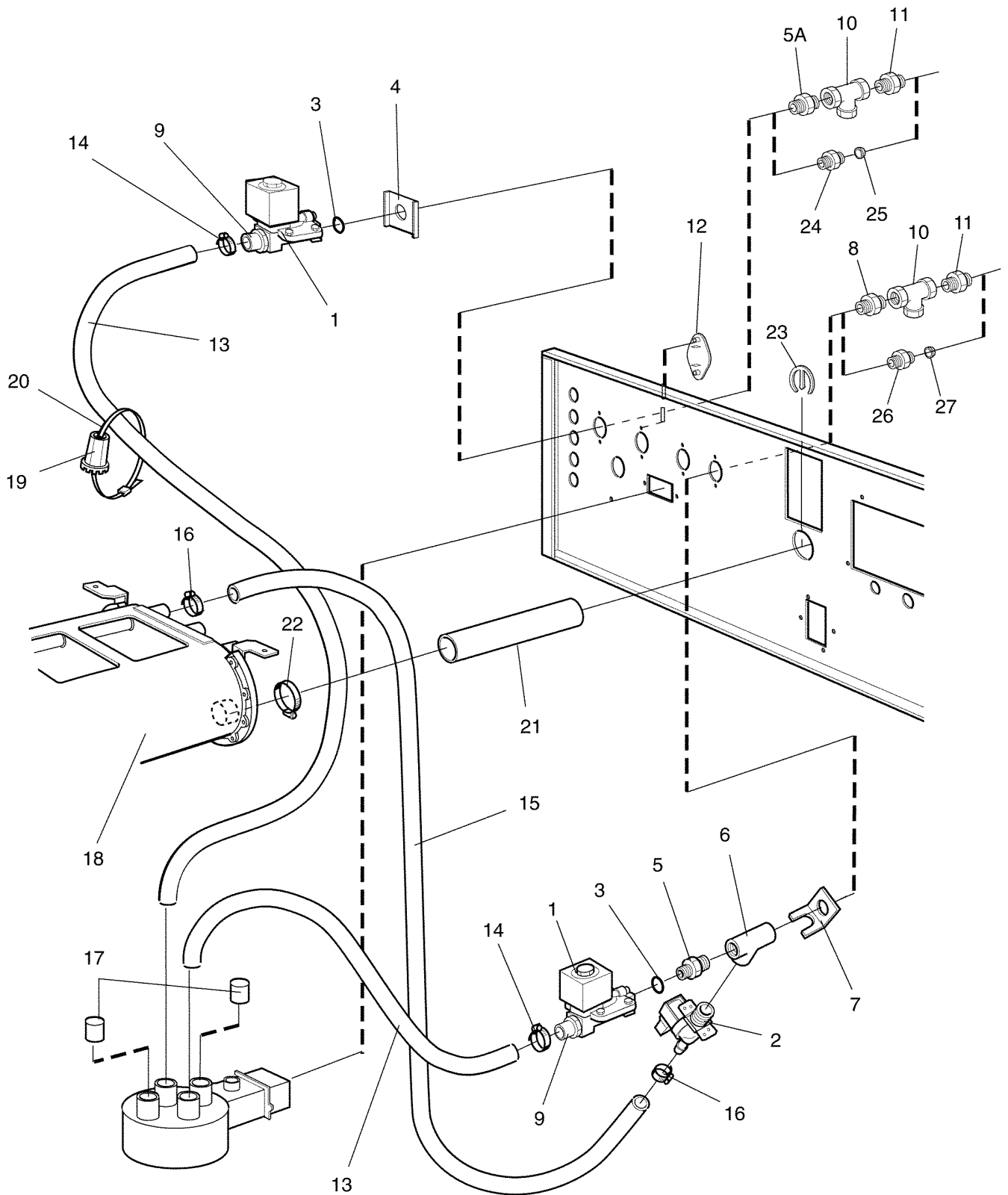

SELECTA 28

Water connections

Raccords d'eau

Illustration Issue Month Year
Schéma Issue Month Year
101446 2 9 1997

Item Article	Qua. Qua.	Art.No Réf. article	Description	Description	Info Info	Notes Remarques
1	2	471 8210-63	Valve	Soupape	1,2	60Hz See group US8125
2	1	471 8234-56	Valve	Soupape	1,2	208-240V See group US8115
3	2	471 8159-06	Gasket	Joint	1	
4	1	471 2937-01	Bracket	Support	3	
5	1	471 8622-01	Nipple	Raccord	3	1/2"-3/4" 50Hz
5A	1	471 8622-01	Nipple	Raccord	3	1/2"-3/4" 50Hz -97/10860
6	1	742 5115-20	T-pipe	Tube en T	3	
7	1	471 2938-01	Cover	Couvercle	3	
8	1	471 8622-05	Nipple	Raccord	3	3/4"
9	2	471 8623-01	Connection	Embrayage	3	1/2"
10	2	744 3115-06	Filter	Filtre	3	R 3/4"
11	2	471 2094-92	Nipple	Raccord	3	60Hz
12	2	472 6761-01	Cover washer	Rondelle protection	3	
13	RQ	877 5252-01	Hose	Flexible	3	PER 1M
14	4	736 2825-51	Hose clamp	Attache flexible	3	Ø32
15	RQ	877 5211-08	Hose	Flexible	3	Per 1 m PER 1M
16	2	736 2816-51	Hose clamp	Attache flexible	3	Ø13-19
17	2	471 8175-01	Plug	Fiche	3	
18	1	438 0253-46	Detergent container	Compartiment à savon		See group US8803
19	1	471 4792-01	Tool	Outil	3	
20	1	762 9105-05	Cable strap	Serre-câble	3	
21	1	438 0145-07	Hose	Flexible	1	
22	1	736 2825-51	Hose clamp	Attache flexible	3	Ø32
23	1	438 0127-01	Lock	Serrure	3	
24	1	471 8693-02	Nipple	Raccord	3	1/2"-3/4" 97/10861-
25	1	471 8693-21	•Filter	•Filtre	1	97/10861-
26	1	471 8693-04	Nipple	Raccord	3	3/4"-3/4" 97/10861-
27	1	471 8693-21	•Filter	•Filtre	1	97/10861-

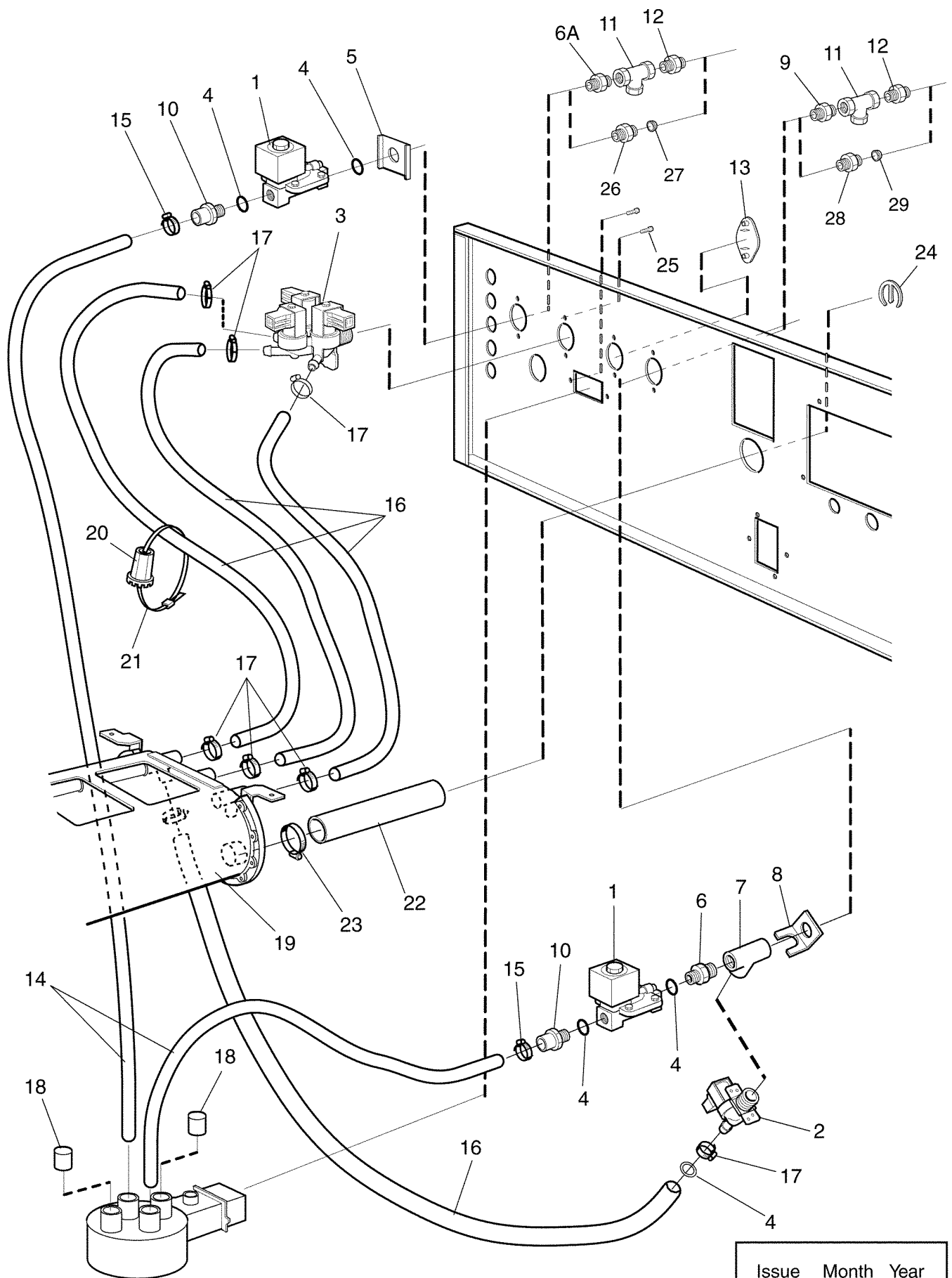

W245 EMERALD

Water connections

Raccords d'eau

Illustration Issue Month Year
Schéma Issue Month Year
101447 2 9 1997

Item Article	Qua. Qua.	Art.No Réf. article	Description	Description	Info Info	Notes Remarques
1	2	471 8210-63	Valve	Soupape	1,2	60Hz See group US8125
2	1	471 8234-54	Valve	Soupape	1,2	208-240V 60Hz 1-way See group US8115
4	2	471 8159-06	Gasket	Joint	1	
5	1	471 2937-01	Bracket	Support	3	
6	1	471 8622-01	Nipple	Raccord	3	1/2"-3/4" 50Hz
6A	1	471 8622-01	Nipple	Raccord	3	1/2"-3/4" 50Hz -97/10860
7	1	742 5115-20	T-pipe	Tube en T	3	
8	1	471 2938-01	Cover	Couvercle	3	
9	1	471 8622-05	Nipple	Raccord	3	3/4" -97/10860
10	2	471 8623-01	Connection	Embrayage	3	1/2"
11	2	744 3115-06	Filter	Filtre	3	R 3/4" -97/10860
12	2	471 2094-92	Nipple	Raccord	3	60Hz -97/10860
13	1	472 6761-01	Cover washer	Rondelle protection	3	
14	RQ	877 5252-01	Hose	Flexible	1	PER 1M
15	4	736 2825-51	Hose clamp	Attache flexible	3	Ø32
16	RQ	877 5211-08	Hose	Flexible	1	Per 1 m PER 1M
17	8	736 2816-51	Hose clamp	Attache flexible	3	Ø13-19
18	2	471 8175-01	Plug	Fiche	3	
19	1	438 0253-45	Detergent container	Compartiment à savon		See group US8803
20	1	471 4792-01	Tool	Outil	3	
21	1	762 9105-05	Cable strap	Serre-câble	3	
22	1	438 0145-07	Hose	Flexible	1	
23	1	736 2825-51	Hose clamp	Attache flexible	3	Ø32
24	1	438 0127-01	Lock	Serrure	3	
25	2	471 8341-11	Screw	Vis	3	MRT 4X6
26	1	471 8693-02	Nipple	Raccord	3	1/2"-3/4" 97/10861-
27	1	471 8693-21	•Filter	•Filtre	1	97/10861-
28	1	471 8693-04	Nipple	Raccord	3	3/4"-3/4" 97/10861-
29	1	471 8693-21	•Filter	•Filtre	1	97/10861-

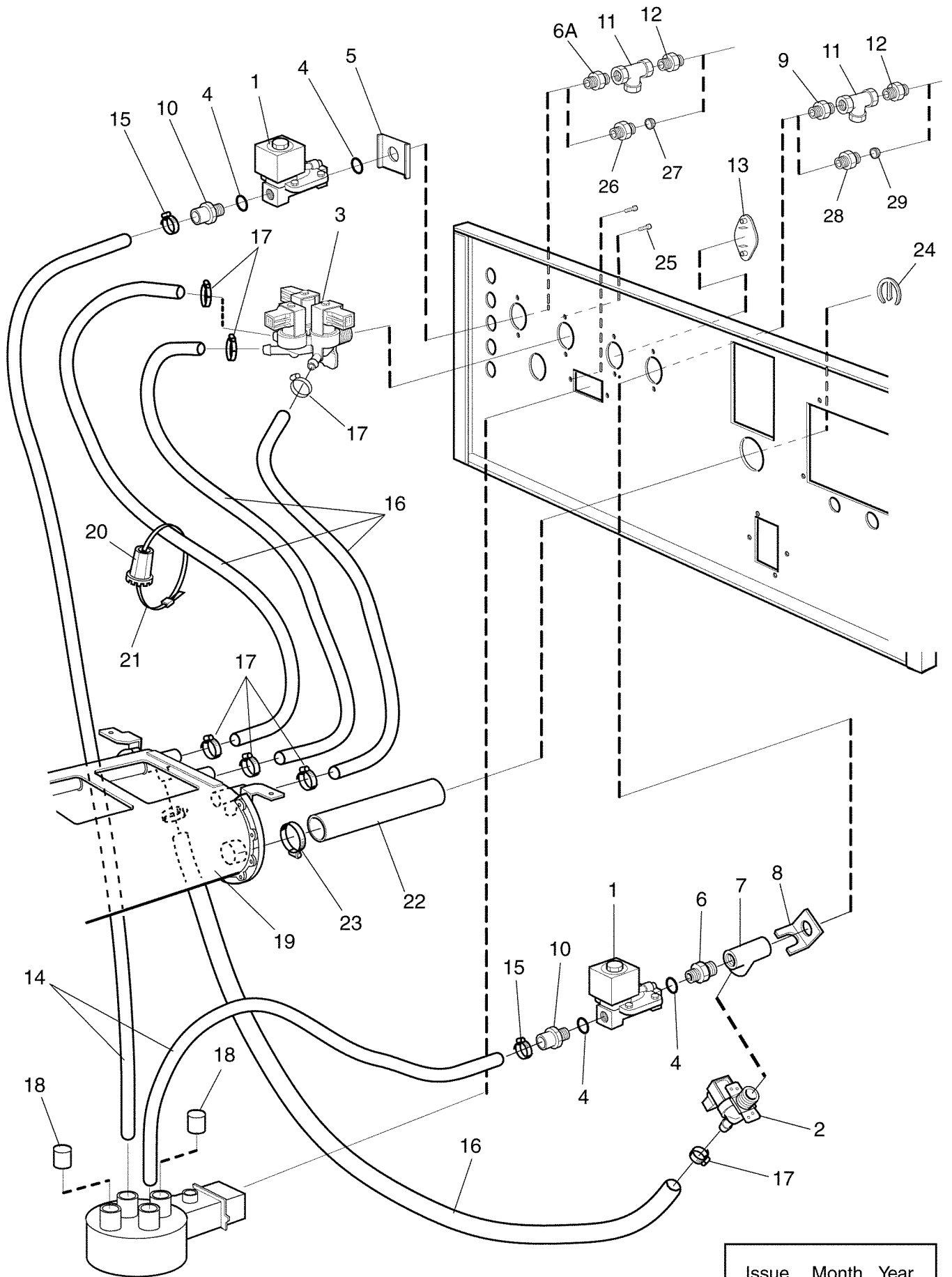

Issue	Month	Year
02	08	97

W245

Water connections

Raccords d'eau

Illustration Issue Month Year
Schéma Issue Month Year
101450 4 11 1997

Item Article	Qua. Qua.	Art.No Réf. article	Description	Description	Info Info	Notes Remarques
1	2	471 8210-63	Valve	Soupape	1,2	60Hz See group US8125
	2	471 8210-02	Valve	Soupape	1,2	1/2" 220-240V 50Hz
2	1	471 8234-54	Valve	Soupape	1,2	208-240V 60Hz 1-way See group US8115
	1	471 8234-52	Valve	Soupape	1,2	208-240V 60Hz See group US8115
3	1	471 8236-65	Valve	Soupape	1,2	EPDM 2, 240V 60Hz 3-way See group US8117
	1	471 8236-64	Valve	Soupape	1,2	208-240V See group US8117
4	2	471 8159-06	Gasket	Joint	3	
5	1	471 2937-01	Bracket	Support	3	
6	1	471 8622-01	Nipple	Raccord	3	1/2"-3/4" 50Hz
	1	471 8622-01	Nipple	Raccord	3	1/2"-3/4" 50Hz -97/10860
7	1	742 5115-20	T-pipe	Tube en T	3	
8	1	471 2938-01	Cover	Couvercle	3	
9	1	471 8622-05	Nipple	Raccord	3	3/4"
10	2	471 8623-01	Connection	Embrayage	3	1/2"
11	2	744 3115-06	Filter	Filtre	3	R 3/4" -97/10860
12	1	471 2094-92	Nipple	Raccord	3	60Hz -97/10860
13	1	472 6761-01	Cover washer	Rondelle protection	3	
14	RQ	877 5252-01	Hose	Flexible	1	PER 1M
15	4	736 2825-51	Hose clamp	Attache flexible	3	Ø32
16	RQ	877 5211-08	Hose	Flexible	1	Per 1 m PER 1M
17	8	736 2816-51	Hose clamp	Attache flexible	3	Ø13-19
18	2	471 8175-01	Plug	Fiche	3	
19	1	438 0253-45	Detergent container	Compartiment à savon		See group US8803
20	1	471 4792-01	Tool	Outil	3	
21	1	762 9105-05	Cable strap	Serre-câble	3	
22	1	438 0145-07	Hose	Flexible	1	
23	1	736 2825-51	Hose clamp	Attache flexible	3	Ø32
24	1	438 0127-01	Lock	Serrure	3	
25	2	471 8341-11	Screw	Vis	3	MRT 4X6
26	1	471 8693-02	Nipple	Raccord	3	1/2"-3/4" 97/10861-
27	1	471 8693-21	•Filter	•Filtre	1	97/10861-
28	1	471 8693-04	Nipple	Raccord	3	3/4"-3/4" 97/10861-
29	1	471 8693-21	•Filter	•Filtre	1	97/10861-

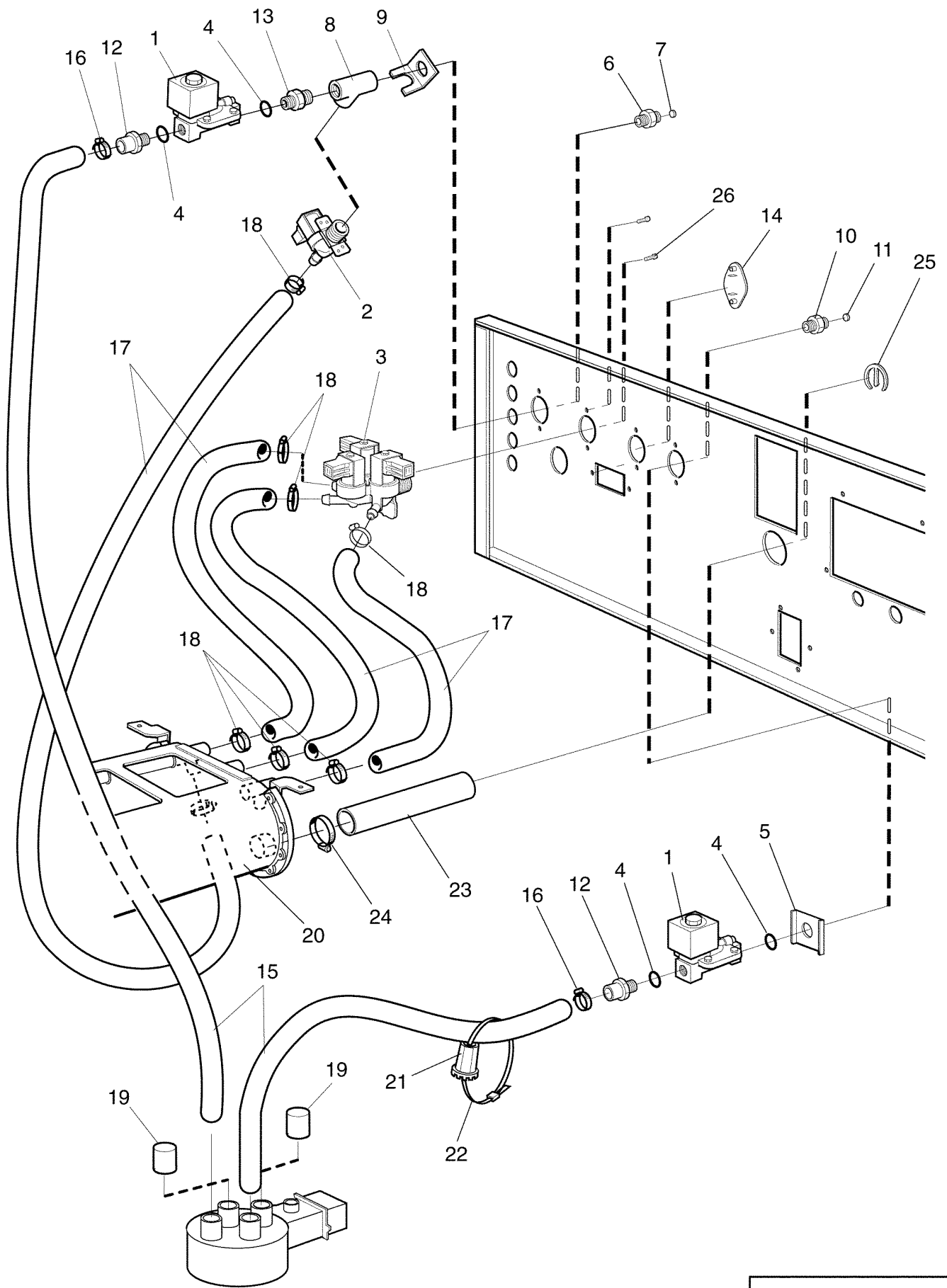

Issue	Month	Year
02	08	97

FL245

Water connections

Raccords d'eau

Illustration Issue Month Year
Schéma Issue Month Year
101467 2 4 1999

Item Article	Qua. Qua.	Art.No Réf. article	Description	Description	Info Info	Notes Remarques
1	2	471 8210-63	Valve	Soupape	1,2	60Hz See group US8125
2	1	471 8234-54	Valve	Soupape	1,2	208-240V 60Hz 1-way See group US8115
3	1	471 8236-65	Valve	Soupape	1,2	EPDM 2, 240V 60Hz 3-way
4	4	471 8159-06	Gasket	Joint	1	
5	1	471 2937-01	Bracket	Support	3	
6	1	471 8693-04	Nipple	Raccord	3	3/4"-3/4"
7	1	471 8693-21	•Filter	•Filtre	1	
8	1	742 5115-20	T-pipe	Tube en T	3	
9	1	471 2938-01	Cover	Couvercle	3	
10	1	471 8693-02	Nipple	Raccord	3	1/2"-3/4"
11	1	471 8693-21	•Filter	•Filtre	1	
12	2	471 8623-01	Connection	Embrayage	3	1/2"
13	1	471 8693-11	Nipple	Raccord	3	1/2"-3/4"
14	1	472 6761-01	Cover washer	Rondelle protection	3	
15	RQ	877 5252-01	Hose	Flexible	1	PER 1 M
16	4	736 2825-51	Hose clamp	Attache flexible	3	Ø32
17	RQ	877 5211-08	Hose	Flexible	1	Per 1 m PER 1M
18	8	736 2816-51	Hose clamp	Attache flexible	3	Ø13-19
19	2	471 8175-01	Plug	Fiche	3	
20	1	438 0253-45	Detergent container	Compartiment à savon	1	See group US8803
21	1	471 4792-01	Tool	Outil	3	
22	1	762 9105-05	Cable strap	Serre-câble	3	
23	1	438 0145-07	Hose	Flexible	1	
24	1	736 2825-51	Hose clamp	Attache flexible	3	Ø32
25	1	438 0127-01	Lock	Serrure	3	
26	2	471 8341-11	Screw	Vis	3	MRT 4X6

1

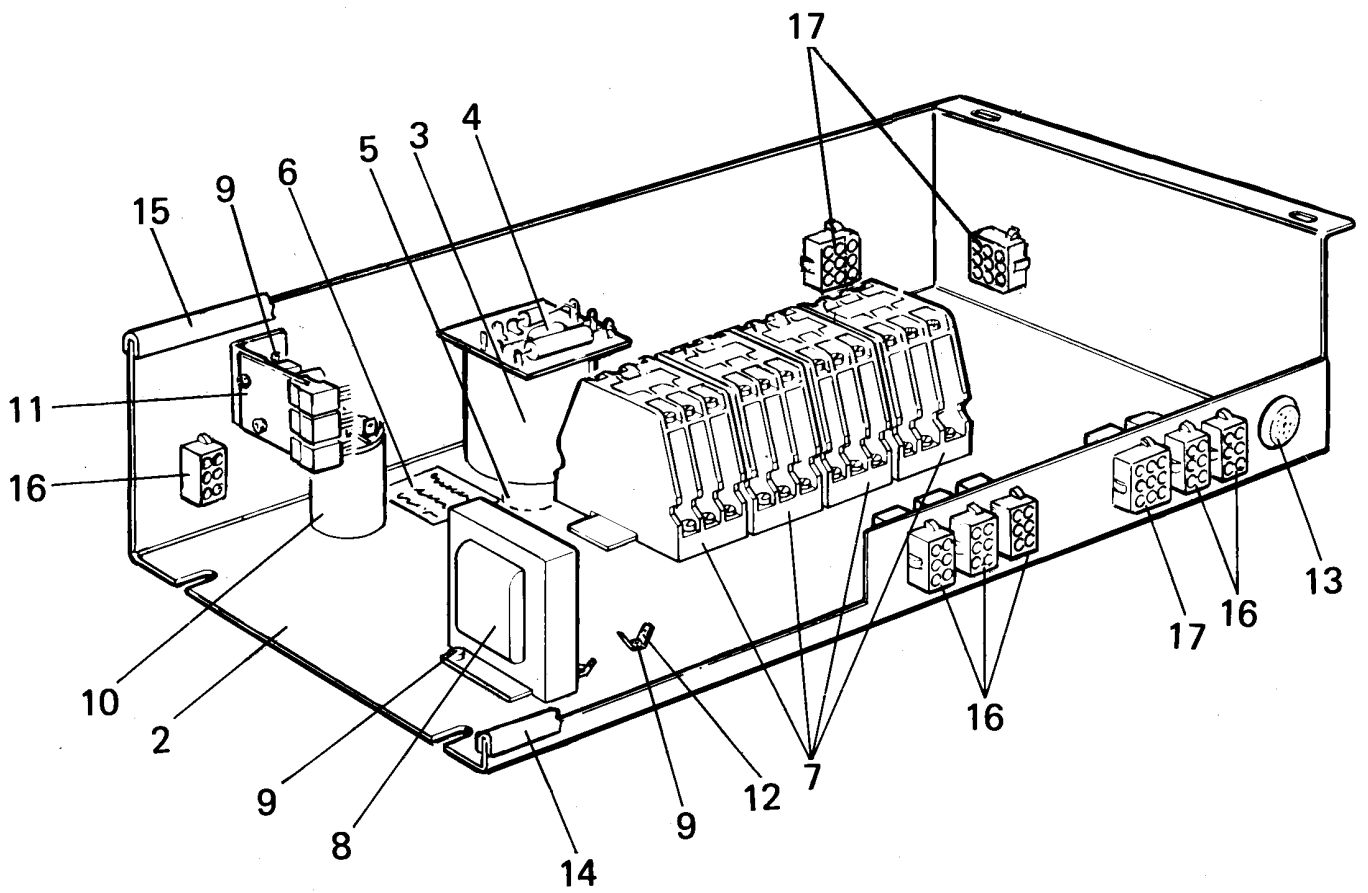

FL245 HI-TEK

Control unit

Unité de commande

Illustration Issue Month Year
Schéma Issue Month Year
101440 1 11 1996

Item Article	Qua. Qua.	Art.No Réf. article	Description	Description	Info Info	Notes Remarques
1	1	438 0533-01	Control unit	Unité de contrôle	3	230V 50Hz Complete
	1	438 0533-02	Control unit	Unité de contrôle	3	240V 50Hz Complete
	1	438 0533-03	Control unit	Unité de contrôle	3	230V 60Hz Complete
2	1	472 6061-04	•Mounting plate	•Plaque de montage	3	
3	1	471 9514-17	•Delay unit	•Bascule de retard	1,2	
4	1		••	••	1,2	
5	2	471 9035-20	••Nut	••Écrou	3	M8
6	1	471 7640-01	••Sign	••Signe	3	
7	1	438 9636-02	•Contactor	•Relais	1,2	50Hz
	4	438 9636-03	•Contactor	•Relais	1,2	60Hz
8	1	471 9550-15	•Transformer	•Transformateur	1	208/220/240/480V
9	6	471 8342-13	•Screw	•Vis	3	MRT-TT 4X10
10	1	471 9529-10	•Power supply filter	•Filtre de filet	1	208-240V
11	1	471 7473-21	•Printed circuit board	•Circuit imprimé	1,2	
12	2	760 2885-21	•Clamp	•Attache	3	
13	1	471 9653-03	•Buzzer	•Console	1	
14	4	471 8180-12	•Strip	•Ruban	3	
15	1	471 8180-13	•Strip	•Ruban	1	
16	RQ	762 3211-01	•Plug connector	•Connexion enfichable	1	6-pole
17	RQ	762 3231-01	•Plug connector	•Connexion enfichable	1	9-POLE

1

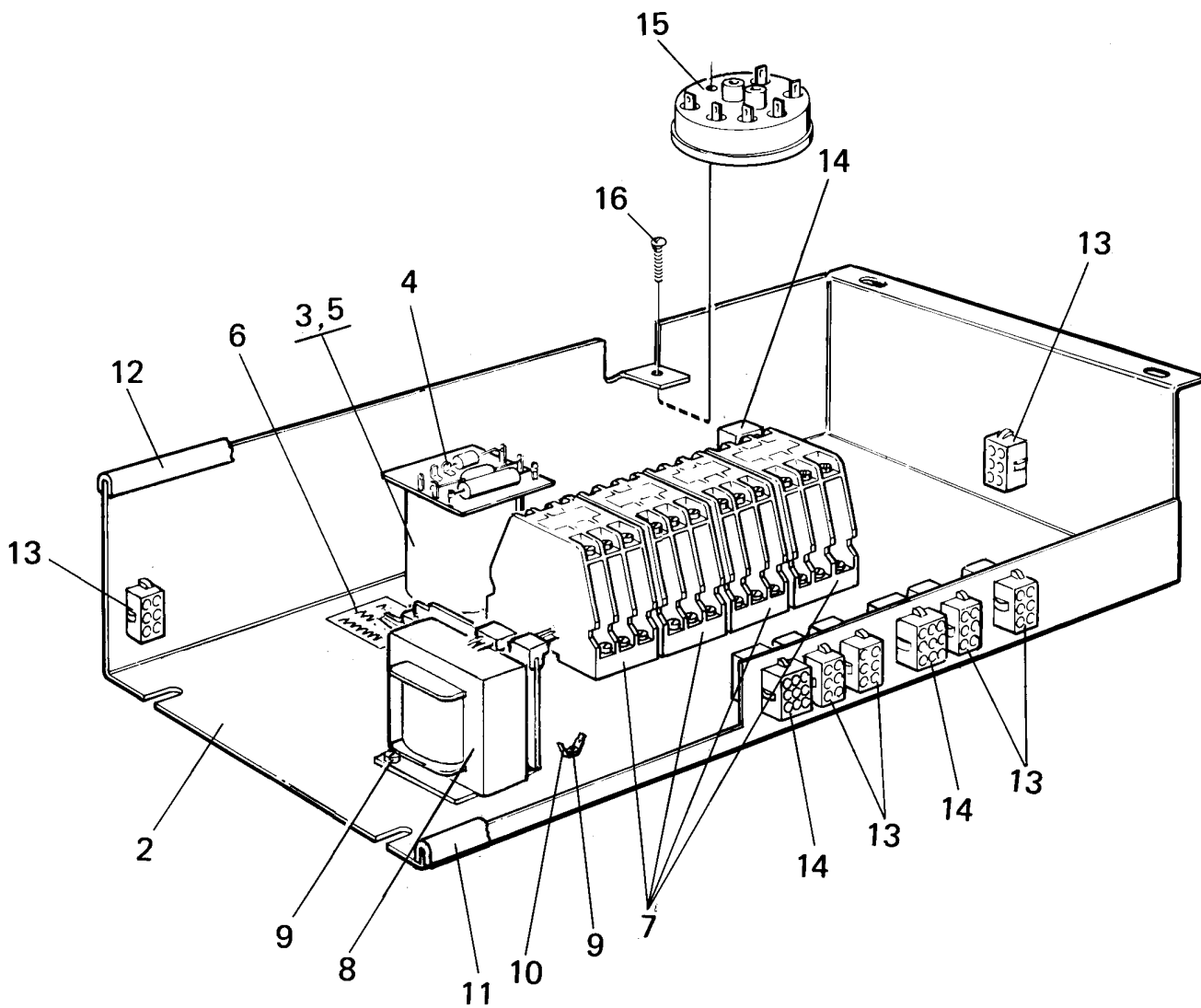

W245 EMERALD

Control unit

Unité de commande

Illustration Issue Month Year
Schéma Issue Month Year
101441 2 8 1997

Item Article	Qua. Qua.	Art.No Réf. article	Description	Description	Info Info	Notes Remarques
1	1	438 0535-01	Control unit	Unité de contrôle	3	240V 60Hz Complete
	1	438 0535-02	Control unit	Unité de contrôle	3	230V 50Hz Complete
2	1	472 6061-04	•Mounting plate	•Plaque de montage	3	
3	1	471 9514-17	•Delay unit	•Bascule de retard	1,2	
4			••	••	1,2	
5	1	471 9035-20	•Nut	•Écrou	3	M8
6	1	471 7640-01	•Sign	•Signe	3	
7	4	438 9636-03	•Contactor	•Relais	1,2	60Hz
	4	438 9636-02	•Contactor	•Relais	1,2	50Hz
8	1	471 9558-03	•Transformer	•Transformateur	1	MP
9	4	471 8342-13	•Screw	•Vis	3	MRT-TT 4X10
10	2	760 2885-21	•Clamp	•Attache	3	
11	1	471 8180-12	•Strip	•Ruban	3	
12	1	471 8180-13	•Strip	•Ruban	3	
13	RQ	762 3211-01	•Plug connector	•Connexion enfichable	3	6-pole
14	RQ	762 3231-01	•Plug connector	•Connexion enfichable	3	9-POLE
15	1	471 8860-11	Level control	Réglage de niveau	1,2	
16	1	471 8317-02	Screw	Vis	3	

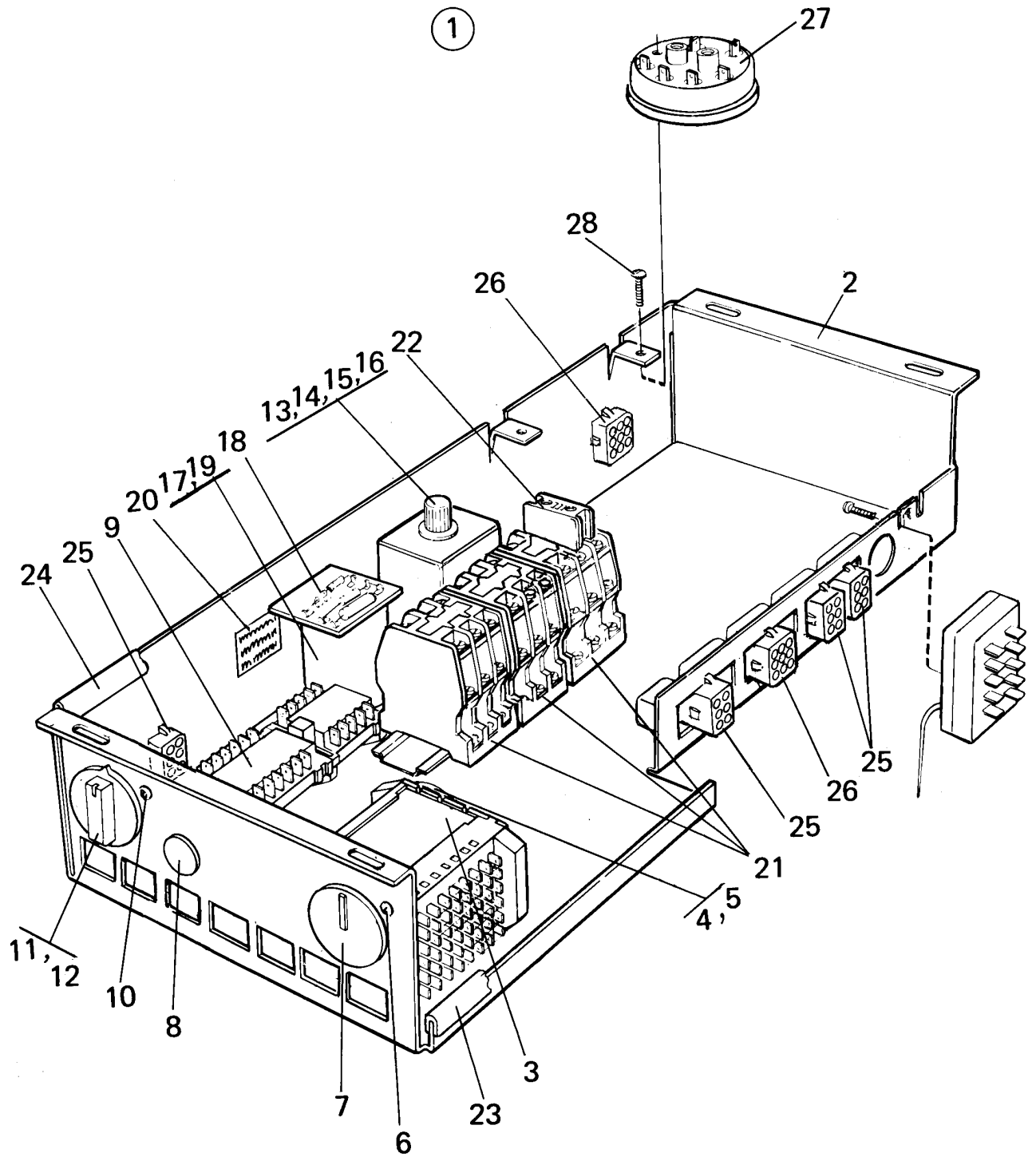

Issue	Month	Year
01	10	96

W245

Control unit P03

Unité de contrôle P03

Illustration Issue Month Year
Schéma Issue Month Year
101442 3 6 1998

Item Article	Qua. Qua.	Art.No Réf. article	Description	Description	Info Info	Notes Remarques
1	1	438 0536-01	Control unit	Unité de contrôle	3	240V 60Hz
	1	438 0536-04	Control unit	Unité de contrôle	3	230V 50Hz
2	1	472 6061-07	•Mounting plate	•Plaque de montage	3	
3	1	471 8950-24	•Program mechanism	•Minuterie	1,2	240V 60Hz
	1	471 8950-23	•Program mechanism	•Minuterie	1,2	230V 50Hz
4	2	471 6655-49	••Motor	••Moteur	1,2	220V 50/60Hz
5	2	471 6661-53	••Clamp	••Bride de fixation	3	
6	2	471 8341-13	•Screw	•Vis	3	MRT 4X10
7	1	472 6082-01	•Pointer	•Indicateur	1	
8	1	763 1101-03	•Pilot lamp	•Lampe témoin	1,2	220V
9	1	471 9617-01	•Program selector	•Commutateur rotatif	1,2	P03
10	2	471 8341-11	•Screw	•Vis	3	MRT 4X6
11	1	438 0076-01	•Knob	•Bouton	1,2	Complete
12	1	471 8159-02	•Gasket	•Joint	3	
13	1	471 9622-04	•Time relay	•Relais temporisé	1,2	50/60Hz
14	1	471 9622-51	•Socket	•Douille	1	
15	2	471 8341-17	•Screw	•Vis	3	M4X25
16	2	731 2312-01	•Nut	•Écrou	3	M4
17	1	471 9514-17	•Delay unit	•Bascule de retard	1,2	
18	1		••	••	1,2	
19	1	471 9035-20	•Nut	•Écrou	3	M8
20	1	471 7640-01	•Sign	•Signe	3	
21	3	438 9636-03	•Contactor	•Relais	1,2	60Hz
	3	438 9636-02	•Contactor	•Relais	1,2	50Hz
22	1	767 5101-92	•Auxiliary contact	•Contact de secours	1,2	HN10 Green
23	1	471 8180-11	•Strip	•Ruban	3	
24	1	471 8180-14	•Strip	•Ruban	3	
25	RQ	762 3211-01	•Plug connector	•Connexion enfichable	3	6-pole
26	RQ	762 3231-01	•Plug connector	•Connexion enfichable	3	9-POLE
27	1	471 8860-09	Level control	Réglage de niveau	1,2	P03
28	1	471 8317-02	Screw	Vis	3	

1

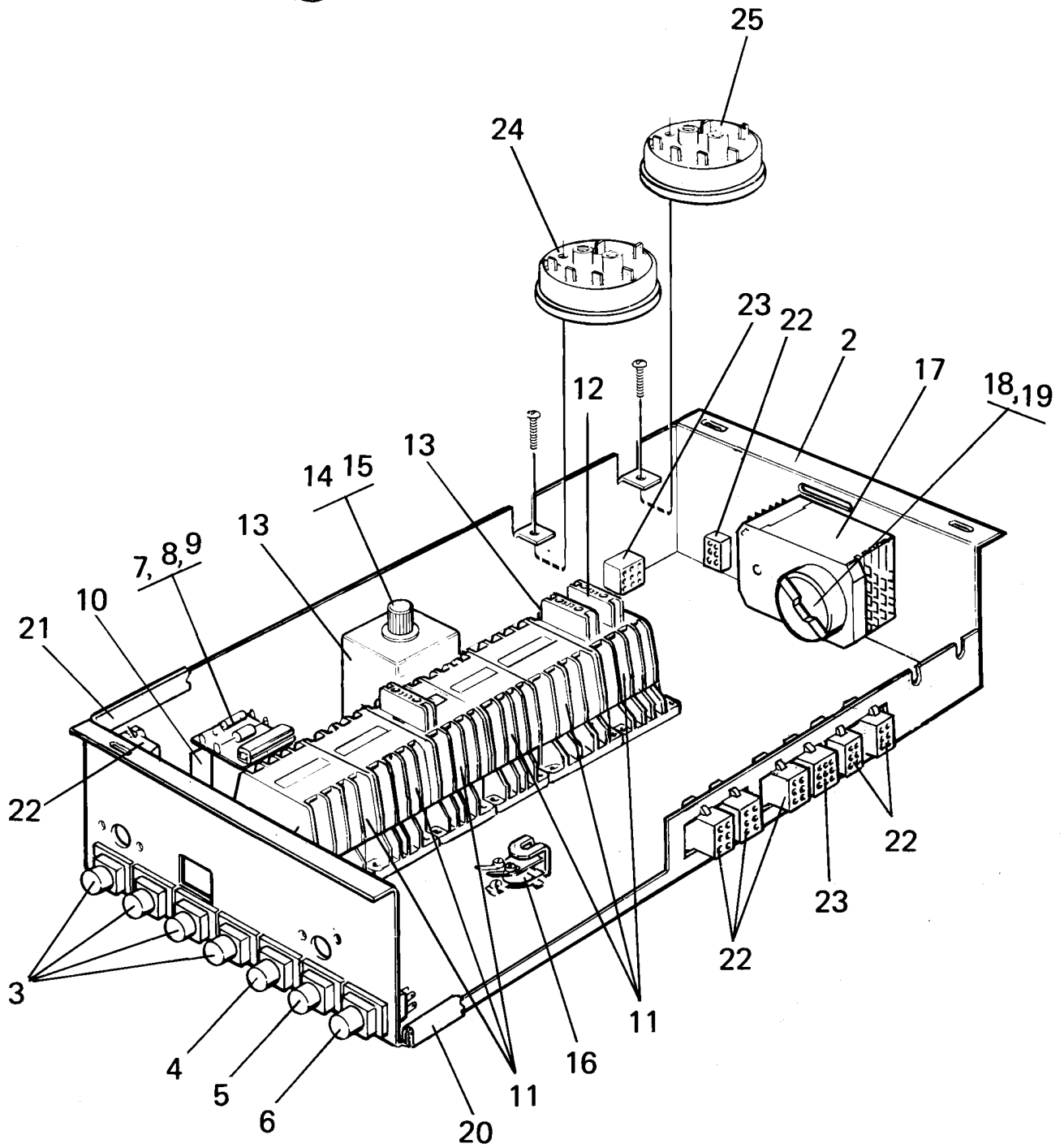

FL245

Control unit

Unité de commande

Illustration Issue Month Year
Schéma Issue Month Year
101466 3 8 1998

Item Article	Qua. Qua.	Art.No Réf. article	Description	Description	Info Info	Notes Remarques
1	1	438 0534-01	Control unit	Unité de contrôle	3	230V 50Hz Complete
	1	438 0534-02	Control unit	Unité de contrôle	3	240V 60Hz Complete
	1	438 0534-03	Control unit	Unité de contrôle	3	230V 60Hz
2	1	472 6061-07	•Mounting plate	•Plaque de montage	3	
3	4	471 9610-05	•Switch	•Commutateur	1,2	
4	1	471 9610-04	•Switch	•Commutateur	1,2	
5	1	471 9610-02	•Switch	•Commutateur	1,2	
6	1	471 9610-06	•Switch	•Commutateur	1,2	
7	1	471 9514-17	•Delay unit	•Bascule de retard	1,2	
8	1		••	••	1,2	
9	1	471 9035-20	••Nut	••Écrou	3	M8
10	1	471 7640-01	•Sign	•Signe	3	
11	6	438 9636-02	•Contactor	•Relais	1,2	50Hz K2-12A
	6	438 9636-03	•Contactor	•Relais	1,2	60Hz K2-2A
12	1	767 5101-92	•Auxiliary contact	•Contact de secours	1,2	HN10 Green
13	2	767 5102-92	•Auxiliary contact	•Contact de secours	1,2	HN01 Red
14	1	471 9622-04	•Time relay	•Relais temporisé	1,2	50/60Hz
15	1	471 9622-51	•Socket	•Douille	1,2	
16	1	471 9651-50	•Buzzer	•Console	3	208-240V
17	1	471 8954-03	•Reverser	•Inverseur	1,2	50Hz
	1	471 8954-04	•Reverser	•Inverseur	1,2	60Hz
18	1	471 6654-55	••Motor	••Moteur	1,2	NEW TIMER 220V 50Hz
	1	471 6661-51	••Motor	••Moteur	1,2	NEW TIMER 230V 60Hz
19	1	471 6536-78	••Clamp	••Bride de fixation	3	
20	1	471 8180-11	•Strip	•Ruban	3	
21	1	471 8180-14	•Strip	•Ruban	3	
22	RQ	762 3211-01	•Plug connector	•Connexion enfichable	3	6-pole
23	RQ	762 3231-01	•Plug connector	•Connexion enfichable	3	9-POLE
24	1	471 8860-11	Level control	Réglage de niveau	1,2	
25	1	471 8860-09	Level control	Réglage de niveau	1,2	High/low

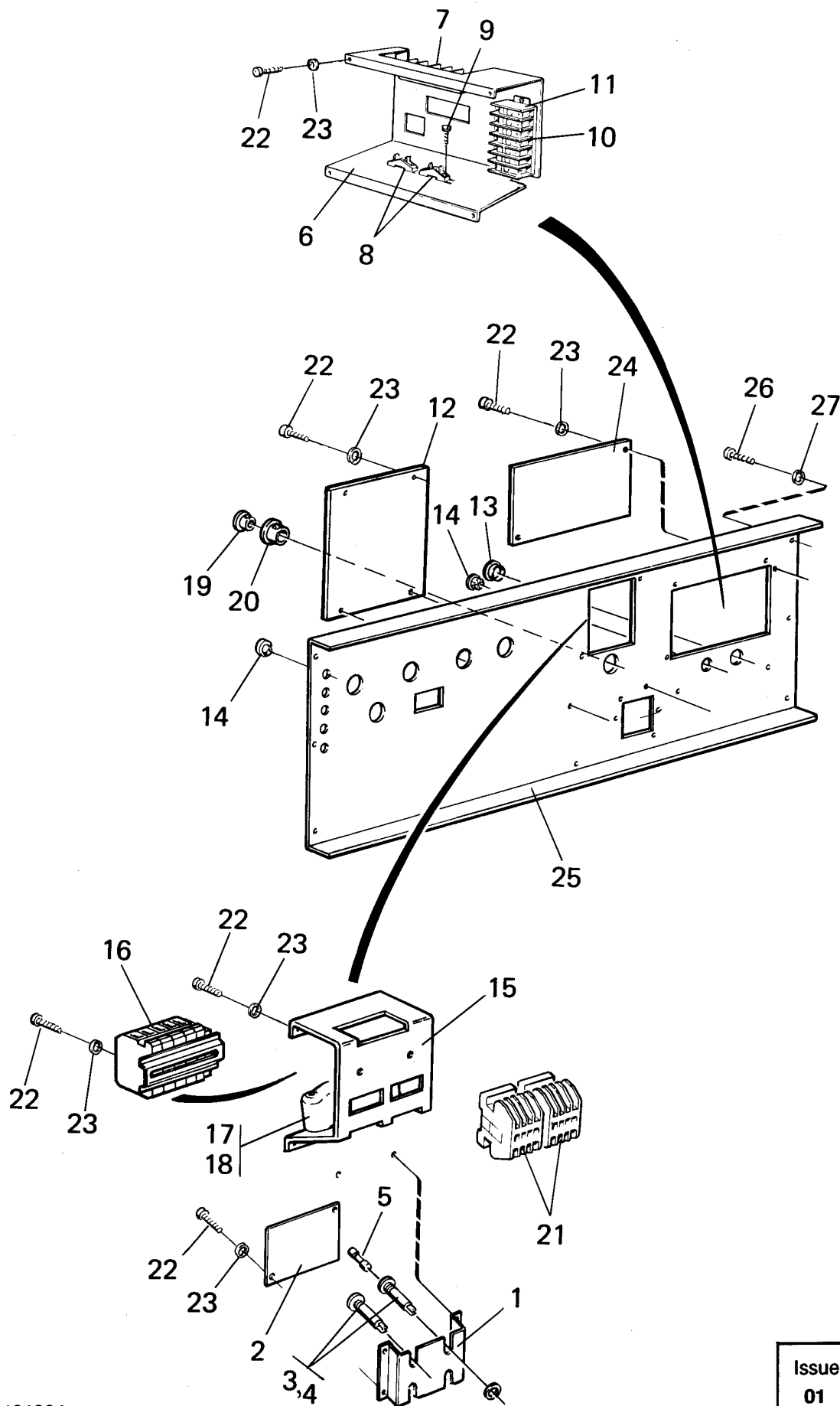

FL245,FL245 HI-TEK,SELECTA 28,W245,W245 EMERALD

Connections components

Illustration Issue Month Year
Schéma Issue Month Year
101391 4 3 1997

Composants de raccordement

Item Article	Qua. Qua.	Art.No Réf. article	Description	Description	Info Info	Notes Remarques
1	1	438 0355-02	Mounting plate	Plaque de montage	3	
2	1	438 0358-02	Cover	Couvercle	3	
3	2	471 8756-01	Fuse holder	Porte-fusible	1	5X20 MM
4	2	471 8756-51	Insert	Insertion	1,2	5X20MM
5	2	471 8750-11	Fuse	Porte-fusible	1,2	1,25A
6	1	438 4243-01	Mounting plate	Plaque de montage	3	
7	1	471 8759-01	Block	Cale	3	
8	2	471 7865-03	Cable clip	Pièce fixation câbles	3	
9	4	471 8346-06	Screw	Vis	3	3,5X25
10	10	471 8760-01	Block	Cale	3	
11	2	471 8760-02	End support	Support	3	
12	1	471 2410-22	Cover	Couvercle	3	
13	1	762 1182-10	Grommet	Oeillet	3	Ø22,2MM
14	6	471 7967-01	Bushing	Douille	3	
15	1	438 0526-01	Plate	Plaque	3	
16	1	471 8762-01	Block	Cale	3	3N AC
17	1	471 7859-11	Clamp	Attache	3	
18	1	471 7859-01			3	
19	1	471 7967-02	Grommet	Oeillet	3	
20	1	762 1215-10	Grommet	Oeillet	3	Ø48/35mm
21	2	438 9636-02	Contactactor	Relais	1,2	50Hz
	2	767 5103-12	Contactactor	Relais	1,2	60Hz
22	RQ	471 8340-23	Screw	Vis	3	RTS 4,2X13
23	RQ	735 2136-01	Lock washer	Rondelle d'arrêt	3	AZ 4,3 4,3
24	1	438 4244-01	Cover	Couvercle	3	
25	1	438 0525-01	Brace bracket	Support de montant	3	HW,DS, USA
	1	438 0525-02	Brace bracket	Support de montant	3	EL, USA
	1	438 0525-03	Brace bracket	Support de montant	3	HW,DS
	1	438 0525-04	Brace bracket	Support de montant	3	El.
26	6	471 8342-25	Screw	Vis	3	5X16
27	6	735 2146-01	Washer	Rondelle	3	M5 5,3
28	1	438 3058-01	Printed circuit board	Circuit imprimé	1,2	
29	1	471 9649-01	Relay	Relais	1,2	
30	1	438 0439-01	Bracket	Pupitre	3	
31	2	471 8340-13	Screw	Vis	3	RTS 3,5X13
32	3	471 7958-01	Support	Support	3	
33	1	471 8180-09	Strip	Ruban	3	L=45

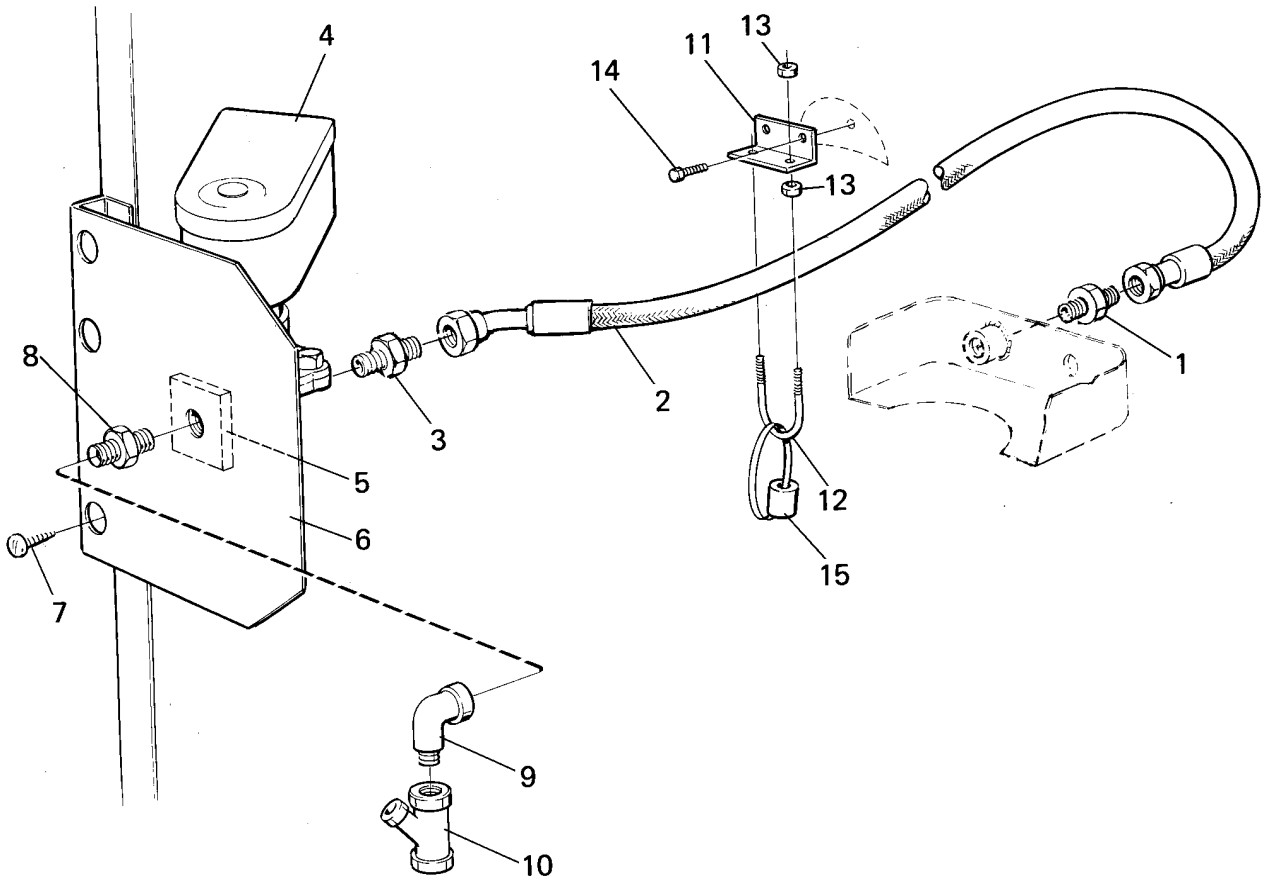

FL245,FL245 HI-TEK,SELECTA 28,W245,W245 EMERALD

Steam components

Illustration Issue Month Year
Schéma Issue Month Year
101073 4 8 2001

Composants

Item Article	Qua. Qua.	Art.No Réf. article	Description	Description	Info Info	Notes Remarques
1	1	438 0168-02	Steam injector	Injecteur de vapeur	1	
2	1	471 8126-18	Hose	Flexible	1,2	L=650
3	1	471 8670-03	Nipple	Raccord	3	
4	1	471 8279-03	Valve	Soupape	1,2	50/60 Hz
	1	471 8279-08	•Repair kit	•Kit de réparation	1,2	
5	1	471 2937-01	Bracket	Support	3	
6	1	438 0167-01	Plate	Plaque	3	
7	3	471 8340-23	Screw	Vis	3	RTS 4,2X13
8	1	471 8622-01	Nipple	Raccord	3	1/2"-3/4" 50Hz
10	1	744 3115-06	Filter	Filtre	3	R 3/4"
11	1	438 0330-01	Bracket	Support de montage	3	
12	1	471 8308-07	Clamp	Bride de fixation	3	
13	4	731 2318-01	Nut	Écrou	3	M8
14	2	725 2366-61	Screw	Vis	3	M6SF 6X12
15	1	438 0341-02	Washer	Rondelle	1	

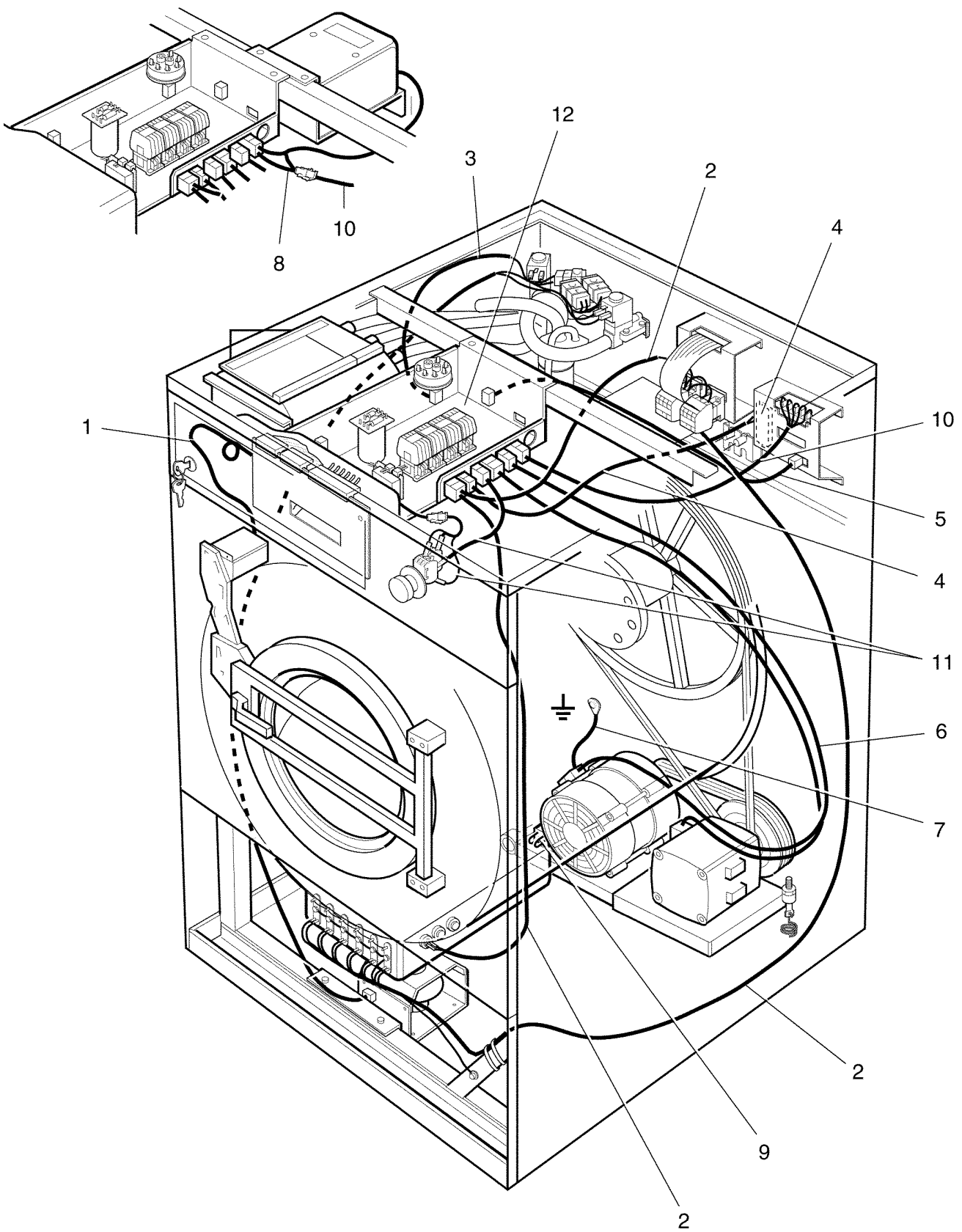

Issue	Month	Year
01	01	97

FL245 HI-TEK

Cables

Câble

Illustration Issue Month Year
Schéma Issue Month Year
101407 2 12 1997

Item Article	Qua. Qua.	Art.No Réf. article	Description	Description	Info Info	Notes Remarques
1	1	472 6485-15	Cables	Câble	3	
2	1	471 4875-71	Cables	Câble	3	24KW 400V Heating
	1	471 4875-72	Cables	Câble	3	24KW 230V Heating
	1	471 4875-80	Cables	Câble	3	
3	1	471 4874-66	Cables	Câble	3	
	1	471 4874-67	Cables	Câble	3	
	1	471 4874-68	Cables	Câble	3	
4	1	471 4878-51	Cables	Câble	3	
5	1	471 4878-55	Cables	Câble	3	
	1	438 3009-04	Cables	Câble	3	
6	1	471 4871-70	Cables	Câble	3	Motor
7	1	471 4878-05	Cables	Câble	3	
8	1	471 4877-04	Cables	Câble	3	TRAFO
9	1	471 8748-03	Cables	Câble	3	230V/400V
	1	471 8748-01	Cables	Câble	3	230V
10	1	471 4872-16	Cables	Câble	3	
11	1	471 4878-34	Cables	Câble	3	
12	1	471 4788-37	Cables	Câble	3	

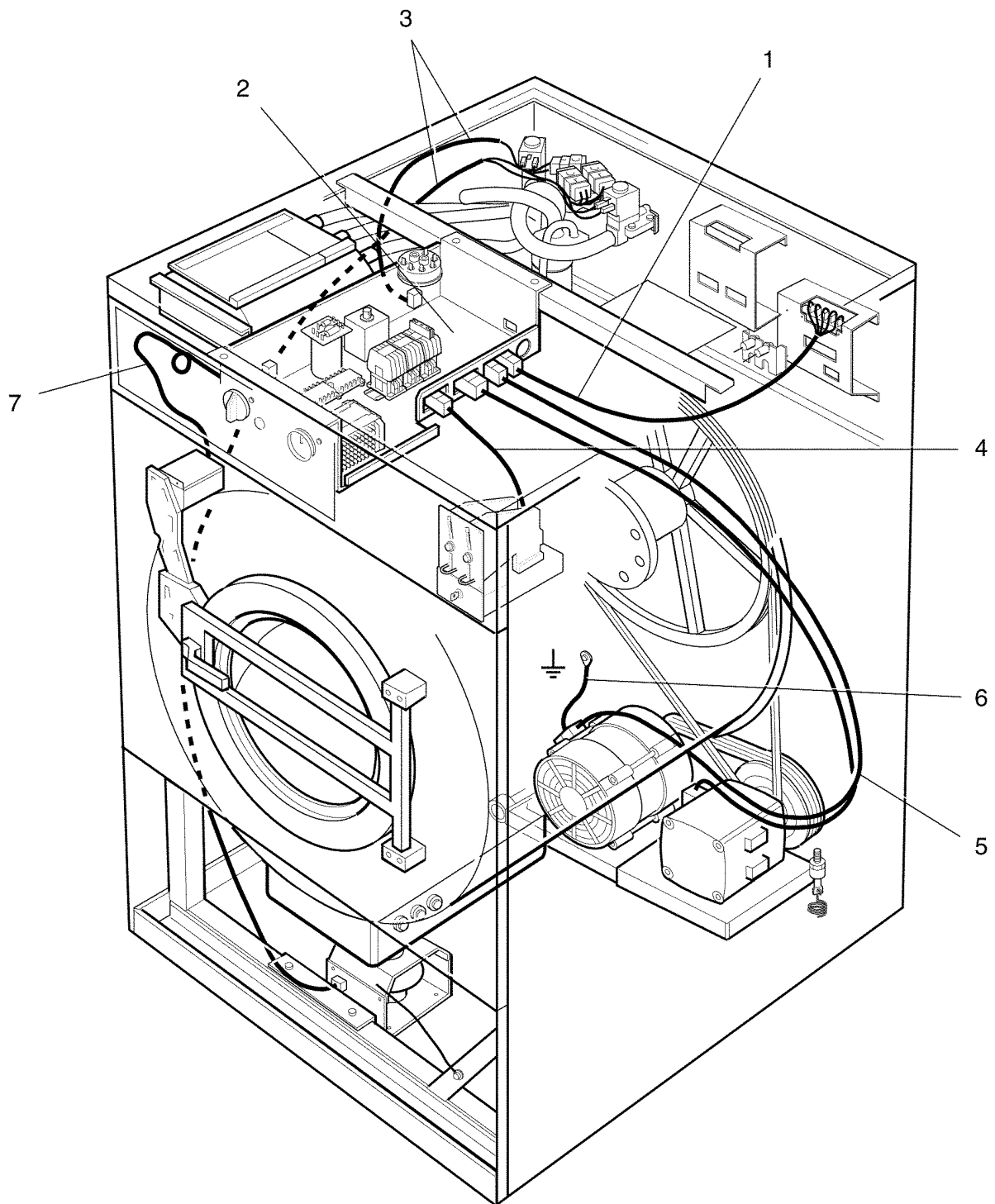

W245

Cables P03

Câblage P03

Illustration Issue Month Year
Schéma Issue Month Year
101470 1 12 1997

Item Article	Qua. Qua.	Art.No Réf. article	Description	Description	Info Info	Notes Remarques
1	1	471 4872-16	Cables	Câble	3	
2	1	471 4870-33	Cables	Câble	3	
3	1	471 4878-63	Cables	Câble	3	
4	1	471 4876-15	Cables	Câble	3	
5	1	471 4871-70	Cables	Câble	3	Motor
6	1	471 4878-05	Cables	Câble	3	
7	1	472 6485-15	Cables	Câble	3	

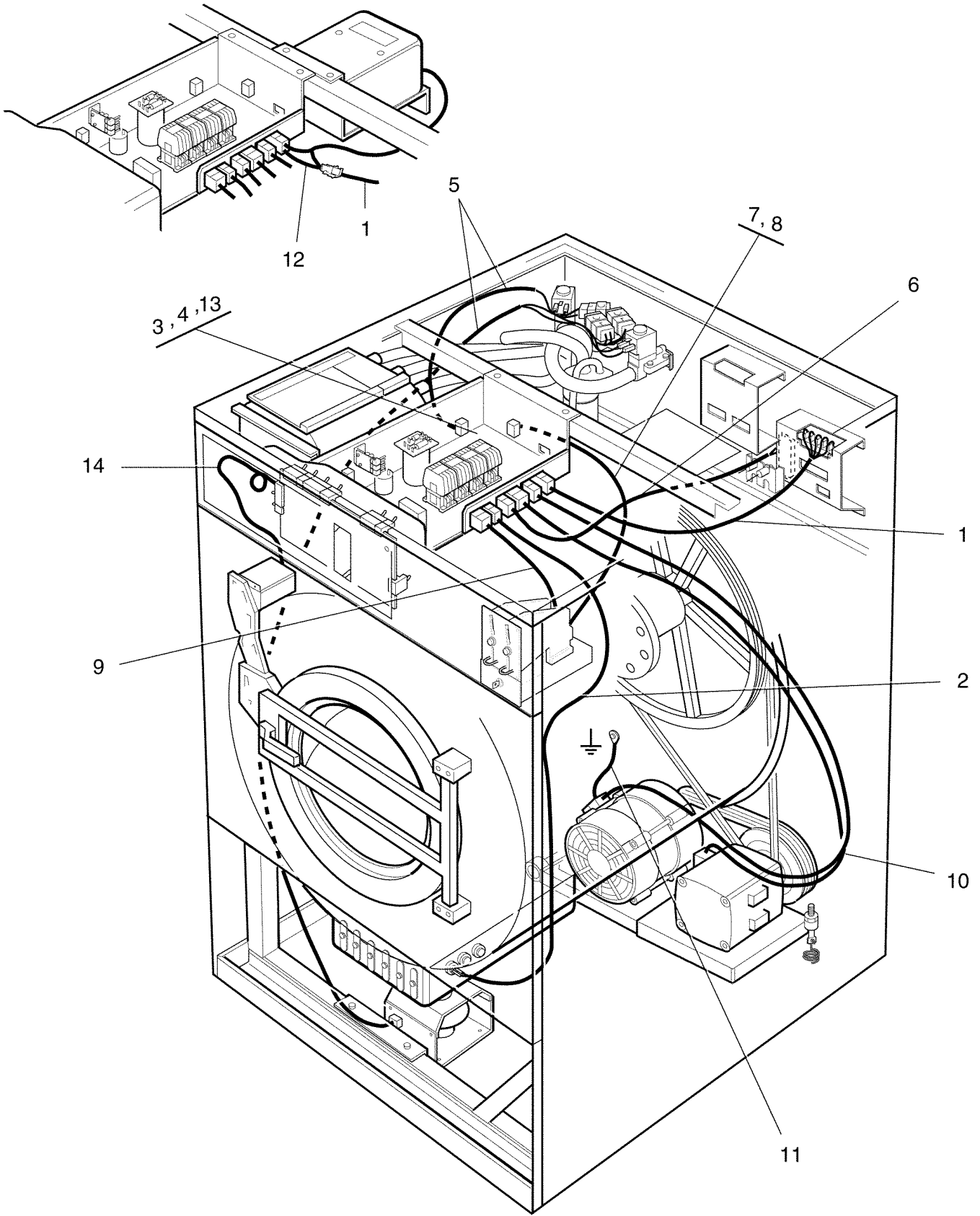

W245 EMERALD

Cables

Illustration Issue Month Year
Schéma Issue Month Year
101472 1 12 1997

Câble

Item Article	Qua. Qua.	Art.No Réf. article	Description	Description	Info Info	Notes Remarques
1	1	471 4872-16	Cables	Câble	3	
2	1	471 4875-43	Cables	Câble	3	Heating
	1	438 3087-07	Cables	Câble	3	
3	1	471 4788-57	Cables	Câble	3	
4	1	438 3014-14	Cables	Câble	3	
5	1	471 4874-64	Cables	Câble	3	
	1	471 4874-65	Cables	Câble	3	
	1	471 4874-68	Cables	Câble	3	
6	1	471 4878-51	Cables	Câble	3	
7	1	471 4876-14	Cables	Câble	3	
8	1	471 4876-13	Cables	Câble	3	
9	1	471 4876-12	Cables	Câble	3	
	1	471 6498-10	Cables	Câble	3	
10	1	471 4871-70	Cables	Câble	3	Motor
11	1	471 4878-05	Cables	Câble	3	
12	1	471 4877-04	Cables	Câble	3	
13	1	438 3031-35	Cables	Câble	3	
14	1	472 6485-15	Cables	Câble	3	

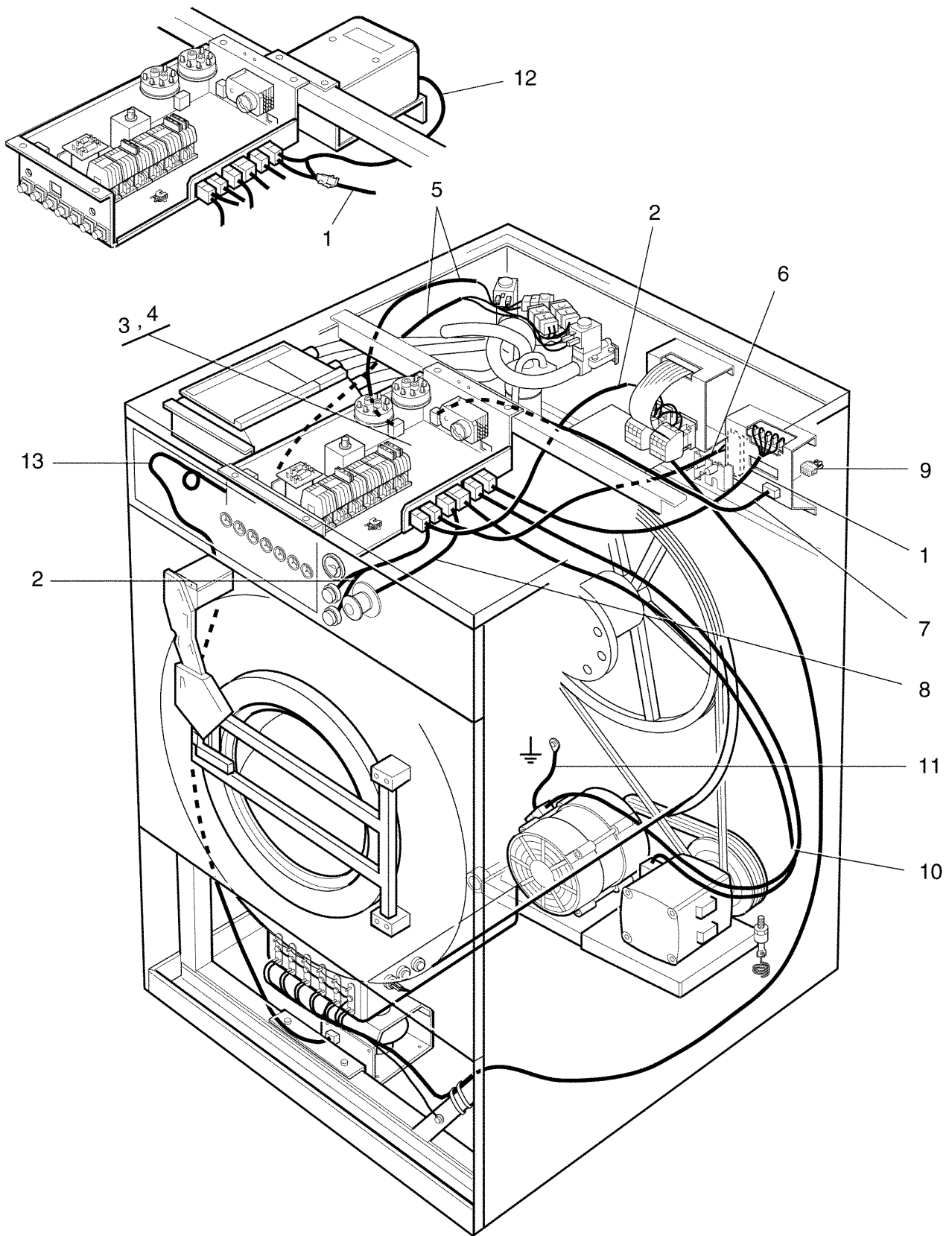

FL245

Cables

Câble

Illustration Issue Month Year
Schéma Issue Month Year
101615 1 12 1997

Item Article	Qua. Qua.	Art.No Réf. article	Description	Description	Info Info	Notes Remarques
1	1	471 4872-16	Cables	Câble	3	
2	1	471 4875-65	Cables	Câble	3	Heating
	1	471 4875-66	Cables	Câble	3	Heating
	1	471 4875-67	Cables	Câble	3	Heating
	1	471 4876-01			3	Heating
3	1	471 4870-62	Cables	Câble	3	
4	1	438 3014-14	Cables	Câble	3	
5	1	471 4874-59	Cables	Câble	3	
	1	471 4874-68	Cables	Câble	3	
6	1	471 4878-51	Cables	Câble	3	
7	1	471 4878-57	Cables	Câble	3	
8	1	471 4878-62	Cables	Câble	3	
9						
10	1	471 4871-70	Cables	Câble	3	Motor
11	1	471 4878-05	Cables	Câble	3	
12	1	471 4877-04	Cables	Câble	3	
13	1	472 6485-15	Cables	Câble	3	

Numerical index/Numerical index

Art.No/Réf. article	Page/Page	Art.No/Réf. article	Page/Page	Art.No/Réf. article	Page/Page	Art.No/Réf. article	Page/Page
432 0919-03	17	438 3014-14	59	471 2431-28	25	471 4782-80	11
438 0033-01	25	438 3019-21	19	471 2431-29	25	471 4788-37	53
438 0076-01	19	438 3031-35	57	471 2432-25	31	471 4788-57	57
438 0076-01	21	438 3058-01	49	471 2438-31	31	471 4792-01	33
438 0076-01	45	438 3087-07	57	471 2439-04	27	471 4792-01	35
438 0079-01	7	438 4009-01	13	471 2439-32	29	471 4792-01	37
438 0127-01	33	438 4009-01	17	471 2439-70	9	471 4792-01	39
438 0127-01	35	438 4009-02	13	471 2439-73	27	471 4829-01	19
438 0127-01	37	438 4009-02	17	471 2439-87	9	471 4829-01	21
438 0127-01	39	438 4088-01	17	471 2439-90	29	471 4830-01	19
438 0145-07	33	438 4088-01	21	471 2440-10	27	471 4830-01	21
438 0145-07	35	438 4093-01	27	471 2440-12	27	471 4862-01	19
438 0145-07	37	438 4100-01	27	471 2440-26	29	471 4862-01	21
438 0145-07	39	438 4101-01	27	471 2440-27	29	471 4870-33	55
438 0167-01	51	438 4117-02	25	471 2440-35	7	471 4870-62	59
438 0168-02	51	438 4118-01	9	471 2440-36	31	471 4871-70	53
438 0253-45	35	438 4126-02	25	471 2440-37	31	471 4871-70	55
438 0253-45	37	438 4127-02	25	471 2440-89	27	471 4871-70	57
438 0253-45	39	438 4128-01	25	471 2441-06	7	471 4871-70	59
438 0253-46	33	438 4130-01	25	471 2441-44	27	471 4872-16	53
438 0330-01	51	438 4132-02	25	471 2449-72	31	471 4872-16	55
438 0334-02	19	438 4147-02	23	471 2451-82	27	471 4872-16	57
438 0341-02	51	438 4148-02	23	471 2459-35	29	471 4872-16	59
438 0355-02	49	438 4150-01	23	471 2535-01	29	471 4874-59	59
438 0358-02	7	438 4152-01	23	471 2538-00	29	471 4874-64	57
438 0358-02	49	438 4155-01	9	471 2539-00	27	471 4874-65	57
438 0426-01	25	438 4157-01	9	471 2574-02	27	471 4874-66	53
438 0439-01	49	438 4171-01	7	471 2904-01	31	471 4874-67	53
438 0456-01	27	438 4171-03	7	471 2937-01	33	471 4874-68	53
438 0457-01	27	438 4171-04	7	471 2937-01	35	471 4874-68	57
438 0458-01	27	438 4171-05	7	471 2937-01	37	471 4874-68	59
438 0459-01	27	438 4171-06	7	471 2937-01	39	471 4875-43	57
438 0522-01	9	438 4171-07	7	471 2937-01	51	471 4875-65	59
438 0522-01	27	438 4172-01	7	471 2938-01	33	471 4875-66	59
438 0523-01	9	438 4172-03	7	471 2938-01	35	471 4875-67	59
438 0524-01	7	438 4172-04	7	471 2938-01	37	471 4875-71	53
438 0524-02	7	438 4172-05	7	471 2938-01	39	471 4875-72	53
438 0524-03	7	438 4172-06	7	471 4401-01	31	471 4875-80	53
438 0525-01	49	438 4172-07	7	471 4402-01	31	471 4876-01	59
438 0525-02	49	438 4178-01	7	471 4402-02	31	471 4876-12	57
438 0525-03	49	438 4243-01	49	471 4403-02	31	471 4876-13	57
438 0525-04	49	438 4244-01	7	471 4417-01	27	471 4876-14	57
438 0526-01	49	438 4244-01	49	471 4427-01	31	471 4876-15	55
438 0527-01	9	438 4326-01	25	471 4437-02	31	471 4877-04	53
438 0527-02	9	438 9636-02	41	471 4442-01	29	471 4877-04	57
438 0527-03	9	438 9636-02	43	471 4447-01	27	471 4877-04	59
438 0528-01	7	438 9636-02	45	471 4469-03	9	471 4878-05	29
438 0528-02	7	438 9636-02	47	471 4516-03	31	471 4878-05	53
438 0529-01	29	438 9636-02	49	471 4521-01	31	471 4878-05	55
438 0532-01	7	438 9636-03	41	471 4525-31	19	471 4878-05	57
438 0533-01	41	438 9636-03	43	471 4525-32	21	471 4878-05	59
438 0533-02	41	438 9636-03	45	471 4527-79	15	471 4878-34	53
438 0533-03	41	438 9636-03	47	471 4586-01	11	471 4878-51	53
438 0534-01	47	471 2059-18	29	471 4647-66	29	471 4878-51	57
438 0534-02	47	471 2074-85	27	471 4647-68	29	471 4878-51	59
438 0534-03	47	471 2094-92	33	471 4647-70	29	471 4878-55	53
438 0535-01	43	471 2094-92	35	471 4657-82	19	471 4878-57	59
438 0535-02	43	471 2094-92	37	471 4705-02	15	471 4878-62	59
438 0536-01	45	471 2095-32	31	471 4705-02	17	471 4878-63	55
438 0536-04	45	471 2265-69	31	471 4705-02	21	471 4878-84	11
438 0699-01	11	471 2401-52	31	471 4714-04	11	471 4904-02	19
438 0699-01	13	471 2410-22	7	471 4714-05	11	471 6498-10	57
438 0699-01	17	471 2410-22	49	471 4782-38	19	471 6536-78	47
438 2807-11	7	471 2416-83	31	471 4782-38	21	471 6654-10	15
438 3009-04	53	471 2420-47	29	471 4782-39	15	471 6654-55	47
438 3014-14	57	471 2425-28	31	471 4782-64	13	471 6655-49	45

Numerical index/Numerical index

Art.No/Réf. article	Page/Page	Art.No/Réf. article	Page/Page	Art.No/Réf. article	Page/Page	Art.No/Réf. article	Page/Page
471 6661-51	47	471 8308-07	51	471 8693-21	33	471 9718-22	29
471 6661-53	45	471 8311-00	27	471 8693-21	35	471 9718-23	29
471 7473-21	41	471 8317-02	43	471 8693-21	37	471 9718-25	29
471 7559-07	7	471 8317-02	45	471 8693-21	39	471 9811-01	9
471 7640-01	41	471 8328-04	27	471 8733-10	11	471 9811-03	9
471 7640-01	43	471 8340-13	49	471 8748-01	53	472 5752-14	13
471 7640-01	45	471 8340-22	29	471 8748-03	53	472 5752-18	17
471 7640-01	47	471 8340-23	7	471 8750-11	49	472 5756-01	11
471 7668-02	25	471 8340-23	13	471 8756-01	49	472 5756-04	11
471 7671-65	25	471 8340-23	17	471 8756-51	49	472 5756-07	11
471 7701-58	29	471 8340-23	49	471 8759-01	49	472 5756-08	11
471 7803-21	23	471 8340-23	51	471 8760-01	49	472 5756-09	11
471 7814-02	25	471 8341-05	17	471 8760-02	49	472 5756-15	11
471 7826-10	7	471 8341-07	17	471 8762-01	49	472 5756-20	11
471 7826-20	7	471 8341-11	15	471 8804-02	15	472 6020-08	31
471 7826-98	7	471 8341-11	35	471 8804-51	15	472 6061-04	41
471 7851-03	31	471 8341-11	37	471 8804-71	15	472 6061-04	43
471 7859-01	49	471 8341-11	39	471 8810-02	15	472 6061-07	45
471 7859-11	49	471 8341-11	45	471 8860-09	45	472 6061-07	47
471 7864-01	7	471 8341-13	7	471 8860-09	47	472 6079-00	15
471 7864-01	9	471 8341-13	45	471 8860-11	43	472 6079-00	19
471 7864-01	25	471 8341-17	45	471 8860-11	47	472 6079-00	21
471 7865-03	49	471 8341-22	7	471 8950-23	45	472 6082-01	19
471 7909-05	7	471 8341-46	9	471 8950-24	45	472 6082-01	21
471 7958-01	49	471 8341-50	25	471 8954-03	47	472 6082-01	45
471 7961-02	25	471 8341-85	25	471 8954-04	47	472 6145-03	7
471 7967-01	49	471 8342-13	19	471 8955-01	15	472 6485-15	53
471 7967-02	49	471 8342-13	41	471 8961-01	15	472 6485-15	55
471 8118-06	31	471 8342-13	43	471 8964-09	13	472 6485-15	57
471 8126-18	51	471 8342-23	17	471 8964-09	17	472 6485-15	59
471 8158-02	7	471 8342-23	21	471 8977-25	11	472 6761-01	33
471 8159-02	45	471 8342-25	49	471 9006-37	29	472 6761-01	35
471 8159-06	33	471 8344-22	7	471 9035-20	41	472 6761-01	37
471 8159-06	35	471 8344-35	7	471 9035-20	43	472 6761-01	39
471 8159-06	37	471 8346-06	49	471 9035-20	45	472 8969-03	13
471 8159-06	39	471 8402-01	27	471 9035-20	47	472 8969-03	17
471 8175-01	33	471 8405-01	7	471 9219-16	15	472 9163-08	7
471 8175-01	35	471 8452-01	7	471 9222-59	27	472 9163-09	7
471 8175-01	37	471 8502-14	27	471 9514-17	41	472 9187-01	23
471 8175-01	39	471 8502-14	29	471 9514-17	43	472 9901-08	25
471 8180-09	49	471 8502-31	29	471 9514-17	45	472 9902-11	27
471 8180-11	45	471 8512-01	27	471 9514-17	47	472 9913-22	9
471 8180-11	47	471 8551-02	27	471 9529-10	41	722 7843-02	17
471 8180-12	9	471 8622-01	33	471 9550-10	29	722 7843-02	21
471 8180-12	41	471 8622-01	35	471 9550-15	41	725 2136-01	9
471 8180-12	43	471 8622-01	37	471 9558-03	43	725 2289-61	7
471 8180-13	41	471 8622-01	51	471 9560-01	27	725 2289-61	19
471 8180-13	43	471 8622-05	33	471 9610-02	47	725 2289-61	29
471 8180-14	45	471 8622-05	35	471 9610-04	47	725 2327-51	29
471 8180-14	47	471 8622-05	37	471 9610-05	47	725 2366-61	7
471 8192-01	9	471 8623-01	33	471 9610-06	47	725 2366-61	9
471 8210-02	37	471 8623-01	35	471 9617-01	45	725 2366-61	29
471 8210-63	33	471 8623-01	37	471 9622-04	45	725 2366-61	51
471 8210-63	35	471 8623-01	39	471 9622-04	47	725 2370-61	23
471 8210-63	37	471 8641-01	7	471 9622-51	45	725 2372-51	29
471 8210-63	39	471 8641-01	9	471 9622-51	47	725 2449-51	29
471 8234-52	37	471 8670-03	51	471 9629-02	17	725 2451-51	29
471 8234-54	35	471 8693-02	33	471 9642-03	19	725 2453-51	29
471 8234-54	37	471 8693-02	35	471 9649-01	49	725 2632-51	9
471 8234-54	39	471 8693-02	37	471 9651-50	47	725 2634-71	27
471 8234-56	33	471 8693-02	39	471 9653-03	41	728 8362-01	29
471 8236-64	37	471 8693-04	33	471 9714-21	29	729 9342-81	9
471 8236-65	37	471 8693-04	35	471 9714-22	29	731 2312-01	45
471 8236-65	39	471 8693-04	37	471 9714-23	29	731 2312-42	7
471 8279-03	51	471 8693-04	39	471 9714-25	29	731 2318-01	29
471 8279-08	51	471 8693-11	39	471 9718-21	29	731 2318-01	51

Numerical index/Numerical index

Art.No/Réf. article	Page/Page	Art.No/Réf. article	Page/Page	Art.No/Réf. article	Page/Page	Art.No/Réf. article	Page/Page
732 2110-01	17	763 1802-01	21				
732 2112-01	7	767 5101-92	45				
732 2112-01	19	767 5101-92	47				
732 2114-01	29	767 5102-92	47				
732 2116-01	29	767 5103-12	49				
732 2118-01	27	877 5211-08	33				
732 2118-01	29	877 5211-08	35				
732 2124-01	9	877 5211-08	37				
732 3116-14	25	877 5211-08	39				
734 1153-09	25	877 5252-01	33				
734 1164-01	29	877 5252-01	35				
734 1186-01	27	877 5252-01	37				
734 1191-01	29	877 5252-01	39				
734 1808-51	19						
735 2136-01	7						
735 2136-01	13						
735 2136-01	17						
735 2136-01	19						
735 2136-01	29						
735 2136-01	49						
735 2146-01	7						
735 2146-01	49						
735 3122-20	29						
735 3126-01	25						
736 2816-51	31						
736 2816-51	33						
736 2816-51	35						
736 2816-51	37						
736 2816-51	39						
736 2825-51	33						
736 2825-51	35						
736 2825-51	37						
736 2825-51	39						
736 2831-51	31						
736 2837-51	31						
736 2840-51	31						
736 2846-51	31						
736 2849-51	31						
742 5115-20	33						
742 5115-20	35						
742 5115-20	37						
742 5115-20	39						
744 3115-06	33						
744 3115-06	35						
744 3115-06	37						
744 3115-06	51						
760 2885-21	41						
760 2885-21	43						
762 1182-10	49						
762 1215-10	49						
762 3211-01	41						
762 3211-01	43						
762 3211-01	45						
762 3211-01	47						
762 3231-01	41						
762 3231-01	43						
762 3231-01	45						
762 3231-01	47						
762 7202-57	17						
762 7207-57	17						
762 9105-05	33						
762 9105-05	35						
762 9105-05	37						
762 9105-05	39						
763 1101-03	45						
763 1802-01	19						

WASCOMAT

461 Doughty Blvd., Inwood, L.I., N.Y. 11096-0338

Telephone: 516-371-4400

Parts and Service FAX: 516-371-4029

Sales and Administration FAX: 516-371-4204